



Designation: E 2004 – 9904

An American National Standard

## Standard Test Method for Facing Cleavage of Sandwich Panels<sup>1</sup>

This standard is issued under the fixed designation E 2004; the number immediately following the designation indicates the year of original adoption or, in the case of revision, the year of last revision. A number in parentheses indicates the year of last reapproval. A superscript epsilon ( $\epsilon$ ) indicates an editorial change since the last revision or reapproval.

*This standard has been approved for use by agencies of the Department of Defense.*

### 1. Scope

1.1 This test method covers the determination of the cleavage force to peel stiff facings from sandwich panels.

1.2 The values stated in inch-pound units are to be regarded as the standard. The SI units given in parenthesis may be approximate, and are for information only.

1.3 *This standard does not purport to address all of the safety concerns, if any, associated with its use. It is the responsibility of the user of this standard to establish appropriate safety and health practices and determine the applicability of regulatory limitations prior to use.*

---

<sup>1</sup> This test method is under the jurisdiction of ASTM Committee E06 on Performance of Buildings and is the direct responsibility of Subcommittee E06.53 on Materials and Processes for Durable Rigidwall Relocatable Structures.

Current edition approved Jan. 10, 1999; April 1, 2004. Published April 2004. Originally approved in 1999. Last previous edition approved in 1999 as E 2004 – 99.

## 2. Referenced Documents

### 2.1 ASTM Standards:<sup>2</sup>

- D 1781 Test Method for Climbing Drum Peel for Adhesives
- E 4 Practices for Force Verification of Testing Machines

## 3. Terminology

### 3.1 Definitions:

3.1.1 *adhesive failure*—failure that is completely within the adhesive layer with no evidence of interfacial disbonding between the core and the adhesive, between the adhesive and the facing, and no evidence of tearing or rupture within the core.

3.1.2 *bond failure*—failure that is interfacial and is either (a) between the adhesive and the core, or (b) between the adhesive and the facing; no core or adhesive failure will be in evidence in this type of failure.

3.1.2.1 *Discussion*—If bond failure occurs it should be specified as to whether it is type (a) or (b).

3.1.3 *core failure*—failure that is completely within the core material and is comprised of a tearing or rupture of the core material with no evidence of interfacial disbonding between the core and the adhesive, within the adhesive itself, or between the adhesive and the facing.

3.1.4 *mixed-mode failure*—failure that shows evidence of more than one of the three failure modes described above.

3.1.4.1 *Discussion*—Visually estimate and report the percent of the total failure surface area that is covered by each type of failure.

## 4. Significance and Use

4.1 This test method determines the cleavage force required to peel stiff facings from the core of sandwich panels, and is used to determine how well the facing is bonded to the core. Test Method D 1781 only works well with flexible facings. As a guideline, the cleavage test method would work better on sandwich panels that have facings with a bending stiffness (EI) of greater than approximately 27.3 lbs-in<sup>2</sup>/inch width (3.09 kN-mm<sup>2</sup>/mm width). This converts to approximately 0.032 in. (0.81 mm) aluminum, 0.023 in. (0.57 mm) steel, and 0.046 in. (1.18 mm) fiberglass facings.

## 5. Apparatus

5.1 *Test Machine*, capable of maintaining a controlled loading rate and indicating the load with an accuracy of  $\pm 1\%$  of the indicated value. The accuracy of the test machine shall be verified in accordance with Practices E 4.

5.2 *Deflectometer*, capable of measuring the displacement with a precision of at least  $\pm 10\%$ .

5.3 *Micrometer gage or caliper*, capable of measuring accurately to 0.01 in. (0.25 mm).

## 6. Test Specimen

6.1 The test specimen shall be from the sandwich panel being evaluated.

6.2 Prepare the specimen according to the dimensions specified in Fig. 1.

6.3 The loading blocks shall be bonded to the specimen with an adhesive or attached with pop-rivets. See Fig. 2.

<sup>2</sup> For referenced ASTM standards, visit the ASTM website, [www.astm.org](http://www.astm.org), or contact ASTM Customer Service at [service@astm.org](mailto:service@astm.org). For *Annual Book of ASTM Standards*, Vol 15.06, volume information, refer to the standard's Document Summary page on the ASTM website.

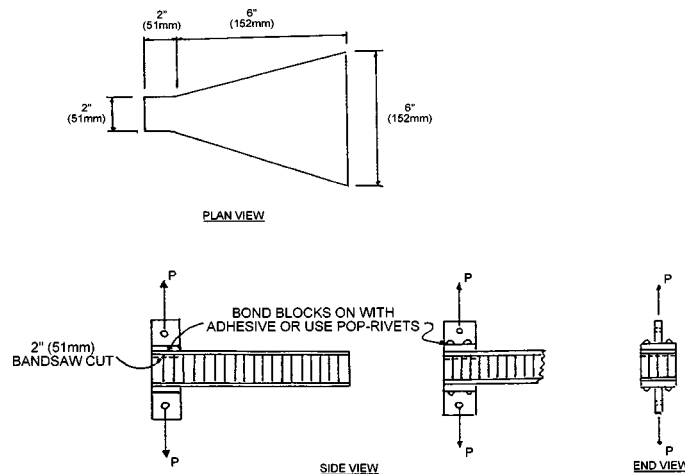

**FIG. 1 Cleavage Test Specimen**

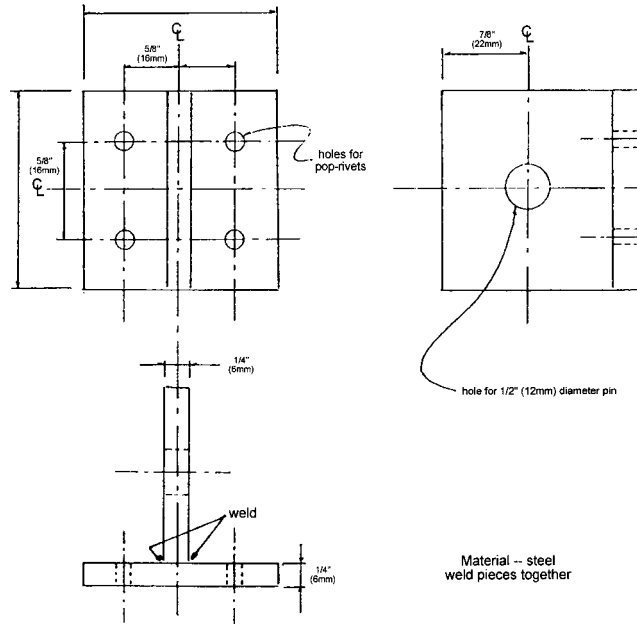

FIG. 2 Loading Blocks for Cleavage Test Specimen

**7. Conditioning**

7.1 When the physical properties of the component materials are affected by moisture, bring the test specimens to constant weight ( $\pm 1\%$ ) before testing, preferably in a conditioning room with temperature and humidity control, and make the tests, preferably, in a room under the same conditions. A temperature of  $73 \pm 5^\circ\text{F}$  ( $23 \pm 3^\circ\text{C}$ ) and a relative humidity of  $30 \pm 5\%$  are recommended.

**8. Procedure**

- 8.1 Mount the specimen in the loading blocks with pins so the loading blocks are free to swivel during the load application.
- 8.2 Apply the load to the blocks at a 1.0 in./min (25.4 mm/min) cross-head travel rate.
- 8.3 Obtain load-deflection curves from cross-head travel.

**9. Calculation**

- 9.1 Determine the peak initial load and the average load after the peak initial load as shown in Fig. 3.

**10. Report**

- 10.1 The report shall include the following:
  - 10.1.1 Description of test specimens, core material, facings, core-to-facing adhesive,
  - 10.1.2 Dimensions of the test specimens, core orientation,
  - 10.1.3 Method of attaching blocks to specimens,
  - 10.1.4 Specimens conditioning, if any,
  - 10.1.5 Test temperature and specimens time at temperature,
  - 10.1.6 Test machine cross-head loading rate,
  - 10.1.7 Peak load, individual values and average, lb (N),
  - 10.1.8 Average load, individual values and average, lb (N),
  - 10.1.9 Load-deflection curves, and
  - 10.1.10 Description of failure mode, whether core, adhesive, bond, or mixed-mode failure occurred.

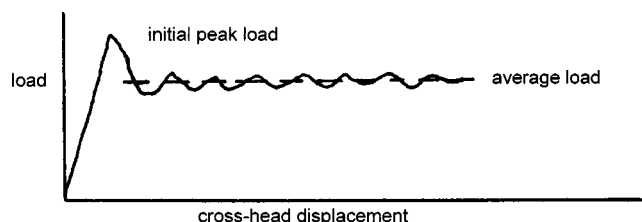

FIG. 3 Determination of Peak Initial Load and Average Initial Load

## 11. Precision and Bias

11.1 *Precision*—The precision of this test method for measuring sandwich facing peel will be determined in the future.

11.2 *Bias*—Since there is no accepted reference material suitable for determining the bias for the procedure in this test method, bias has not been determined.

## 12. Keywords

12.1 cleavage; facing; peel; sandwich core

*ASTM International takes no position respecting the validity of any patent rights asserted in connection with any item mentioned in this standard. Users of this standard are expressly advised that determination of the validity of any such patent rights, and the risk of infringement of such rights, are entirely their own responsibility.*

*This standard is subject to revision at any time by the responsible technical committee and must be reviewed every five years and if not revised, either reapproved or withdrawn. Your comments are invited either for revision of this standard or for additional standards and should be addressed to ASTM International Headquarters. Your comments will receive careful consideration at a meeting of the responsible technical committee, which you may attend. If you feel that your comments have not received a fair hearing you should make your views known to the ASTM Committee on Standards, at the address shown below.*

*This standard is copyrighted by ASTM International, 100 Barr Harbor Drive, PO Box C700, West Conshohocken, PA 19428-2959, United States. Individual reprints (single or multiple copies) of this standard may be obtained by contacting ASTM at the above address or at 610-832-9585 (phone), 610-832-9555 (fax), or [service@astm.org](mailto:service@astm.org) (e-mail); or through the ASTM website ([www.astm.org](http://www.astm.org)).*