



Standard Practice for Operation of a Roller Chair Tester for Pile Yarn Floor Coverings¹

This standard is issued under the fixed designation D 6962; the number immediately following the designation indicates the year of original adoption or, in the case of revision, the year of last revision. A number in parentheses indicates the year of last reapproval. A superscript epsilon (ϵ) indicates an editorial change since the last revision or reapproval.

1. Scope

1.1 This practice covers a procedure for the operation of a weighted roller chair testing device that rotates and moves across a test specimen of pile yarn floor coverings.

1.2 This practice is applicable for testing unused pile yarn floor covering of all types.

1.3 The values stated in SI units are to be regarded as the standard. The inch-pound units given in parenthesis are for information only.

1.4 *This standard does not purport to address all of the safety concerns, if any, associated with its use. It is the responsibility of the user of this standard to establish appropriate safety and health practices and determine the applicability of regulatory limitations prior to use.*

2. Referenced Documents

2.1 *ASTM Standards:*²

D 123 Terminology Relating to Textiles

D 1776 Practice for Conditioning and Testing Textiles

D 2240 Standard Test Method for Rubber Property—Durometer Hardness

D 5684 Terminology Relating to Pile Floor Coverings

3. Terminology

3.1 *Definitions:*

3.1.1 For definitions of pile yarn floor covering related terms used in this standard, refer to Terminology D 5684.

3.1.2 For definitions of other textile terms used in this standard, refer to Terminology D 123.

4. Summary of Test Method

4.1 The carpet test specimen is secured to a table with the pile surface exposed and is subjected to the action of three castors which produce an eccentric turning motion under a

weighted roller chair device that moves across the test specimen for a specified number of cycles.

5. Significance and Use

5.1 This practice is applicable for use in testing the durability of pile yarn floor covering of all types.

5.2 This practice is designed to simulate the stress on a pile yarn floor covering from the action of weighted roller chair casters over an extended period of time.

5.3 The specimen is tested under conditions that may simulate an actual flooring installation. This may include the pile yarn floor covering plus a specified underlayment cushion. This practice is used to prepare specimens for additional testing, including but not limited to: visual assessment of delamination of the secondary backing, visual assessment of the pile surface, resistance to delamination measurement, tuft bind, and pile yarn raveling.

5.4 This practice is used to prepare specimens for additional testing, including but not limited to: visual assessment of delamination of the secondary backing, visual assessment of the pile surface, resistance to delamination measurement, tuft bind, and pile yarn raveling.

6. Apparatus and Materials

6.1 *Roller Chair Tester* is constructed of steel with a rotating circular table and a weighted roller fixture, rotating off-center to the table. The apparatus also has electronic controls, a protective cage, and a vacuum system to remove lint and dust. The area of contact between the rollers and the pile yarn wear will be an annulus with an outside diameter of 600 ± 15 mm (23.6 ± 0.6 in.) and inside diameter of 100 ± 15 mm (3.9 ± 0.6 in.).

6.1.1 Rotating circular table is 795 ± 10 mm (31.3 ± 0.4 in.) diameter and 12 ± 1 mm (0.5 ± 0.1 in.) thick with two stabilizing bolts positioned to prevent the specimen from moving during the test. The base plate rotates at a speed of 2.1 ± 0.4 rad/s (20 ± 4 r/min). The disc base plate rotates in one direction for approximately 3 min and then stops for 3 to 5 s before reversing direction.

6.1.2 The roller fixture is offset 198 ± 4 mm (7.8 ± 0.2 in.) from the center of the base plate and has three chair castor wheels that are 50 ± 1 mm (2 ± 0.1 in.) diameter by 20 ± 1

¹ This practice is under the jurisdiction of ASTM Committee D13 on Textiles and is the direct responsibility of Subcommittee D13.21 on Pile Yarn Floor Coverings. Current edition approved March 1, 2004. Published March 2004. Originally approved in 2003. Last previous edition approved in 2003 as D 6962-03.

² For referenced ASTM standards, visit the ASTM website, www.astm.org, or contact ASTM Customer Service at service@astm.org. For *Annual Book of ASTM Standards* volume information, refer to the standard's Document Summary page on the ASTM website.

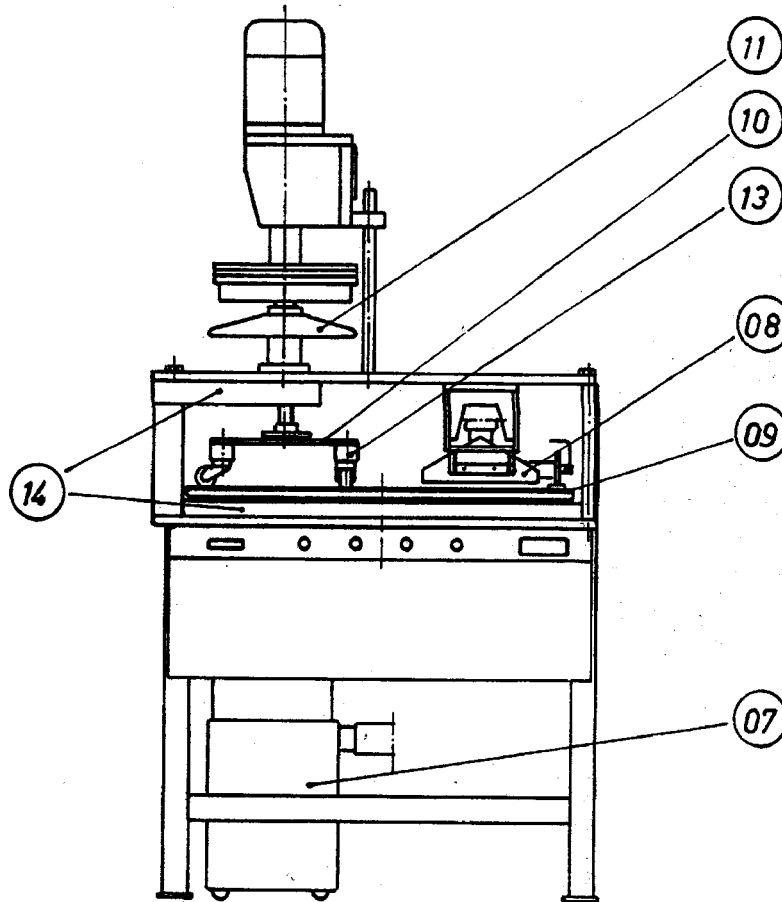

- 07—Vacuum Cleaner
- 08—Suction Nozzle
- 09—Base Table
- 10—Roller Fixture
- 11—Handwheel and weighted disks
- 13—Chair Castors
- 14—Chain guards

FIG. 1 Roller Castor Chair Tester

mm (0.75 ± 0.1 in.) wide made of polyamide. Hardness is $95 \pm 5^\circ$ Shore A, as measured by Test Method D 2240 for Rubber Property—Durometer Hardness. The three wheels are positioned 130 ± 2 mm (5.1 ± 0.1 in.) from the center of the fixture and staggered by 2.1 ± 0.1 radians (120°) around the circle. The wheels are offset from the position in the fixture by 32 ± 2 mm (1.3 ± 0.1 in.) so as to lag behind during the rotary motion of the fixture.

6.1.3 Motor drive controls the rotation of the circular table and the roller fixture simultaneously at a speed of 6.0 ± 0.5 rad/s (57 ± 5 r/min).

6.1.4 Weighted disks provide a force of 30 kg per roller for a total of 90 ± 2 kg (198 ± 4 lb). A handwheel on a screw is used to engage weights and raise or lower the roller fixture.

6.1.5 Protective cage covers the rotating table and roller fixture and is in place before operation of the electric motor begins.

6.1.6 Vacuum cleaner with suction hose is attached to a height adjustable head to remove lint and residue during testing. The width of the vacuum head extends across the

section traveled by the castor chair wheels. The suction opening is $75\,000 \pm 5,000$ mm² (120 ± 8 in²). The suction efficiency is 27 ± 3 L/s (60 ± 6 ft³/min). The vacuum system will operate for 1 to 1.5 min for every 5 min of operation of the equipment.

6.1.7 The following controls and safety interlocks for the motor are used. Refer to the manufacturer's operation guide regarding other controls and operations:

6.1.7.1 Digital counter with setpoint and reset buttons to measure and control the total number of cycles of rotation.

6.1.7.2 Safety limit switches interlocked to the motor to prevent access to rotating parts during operation.

6.1.7.3 Limit switch in the sample area interlocked to the motor to prevent damage to the equipment in the event the specimen obstructs the rotational path.

6.2 Specimen backing sheet of rigid acrylic or comparable material is 790 ± 4 mm (31.25 ± 0.13 in.) diameter and approximately 15 mm (0.6 in.) thick.

6.2.1 1 Alternately, use particle board or AC grade plywood with the A-side in contact with the specimen, approximately 6

to 16 mm (0.25 to 0.625 in.) thick, depending upon the thickness of the composite of carpet, underlayment, adhesive, and backing sheet, to permit adequate clearance between the top of the carpet and limit switch.

NOTE 1—A thickness of approximately 16 mm (0.625 in.) is preferred to maintain a rigid and stable substrate.

6.2.2 Either a circular or semicircular specimen template or die is used to cut the carpet specimen. A 790 ± 4 mm (31.25 ± 0.13 in.) diameter acrylic sheet is preferred.

6.3 Underlayment cushion may be used to simulate the specific pile yarn floor covering installation. Choose from one of the many choices of commercially available underlayments.

6.4 The pile yarn floor covering specimen, underlayment cushion (if used), and specimen backing sheet shall be secured together following standard pile yarn floor covering installation methods or alternate methods. This composite will be termed the test specimen assembly.

6.4.1 A flooring adhesive may be applied according to the guidelines of the manufacturer to secure the test specimen or the underlayment and test specimen directly to the backing sheet.

6.4.2 Alternate methods may be used to secure the test specimen and underlayment to the backing sheet, including but not limited to: double sided tape, knitted nylon coated with a pressure sensitive adhesive, tack strips, and wood screws if the specimen is mounted on plywood.

6.5 An upright vacuum cleaner, with a rotating brush and beater bar, unless this type of apparatus is not recommended by the manufacturer of the pile yarn floor covering under test, in which case the appropriate recommended device should be used.

7. Sampling

7.1 Perform this practice on a test specimen of pile yarn floor covering measuring 790 ± 4 mm (31.25 ± 0.13 in.) diameter using a circular template or die.

7.1.1 If a semi-circular test specimen is required, use a straight edge and razor knife to cut the specimen in the direction of manufacture into two semicircles.

7.1.2 Alternately, use a semi-circular template or die to cut a test specimen.

8. Conditioning

8.1 Condition the specimens as directed in Practice D 1776 in the standard atmosphere for testing textiles, which is $21 \pm 1^\circ\text{C}$ ($70 \pm 2^\circ\text{F}$) and $65 \pm 2\%$ relative humidity, for 24 h or until the specimen mass changes no more than 0.1 % in 2 h.

9. Preparation of Test Specimens

9.1 Direct Adhesion to the Backing Sheet:

9.1.1 Apply flooring adhesive according to the guidelines of the manufacturer to the backing sheet and attach either a full circle test specimen or two semicircle specimens such that the straight edges are joined together.

9.1.2 Place a backing sheet on the pile side of the specimen and apply a mass of 2.5 to 5.0 kg (5.5 to 11.0 lb) evenly distributed on the surface of the test specimen to prevent curling of the specimen while the adhesive is curing for a minimum of 12 h.

9.1.3 Remove the mass and allow the test specimen to condition for a minimum of 4 days while the adhesive cures. Maintain sufficient airflow around the sample to permit evaporation of the solvent or water from the test specimen.

9.2 Direct Adhesion to an Underlayment:

9.2.1 First secure the underlayment to the backing sheet with the flooring adhesive according to the guidelines of the manufacturer. After the adhesive has set, secure the test specimen to the underlayment as in 9.1.

9.3 Alternative Adhesion Methods for Full Circle Specimens:

9.3.1 Attach a full circle carpet specimen to an acrylic or wood backing sheet using double-faced pressure sensitive tape or adhesive coated knitted mesh material and condition.

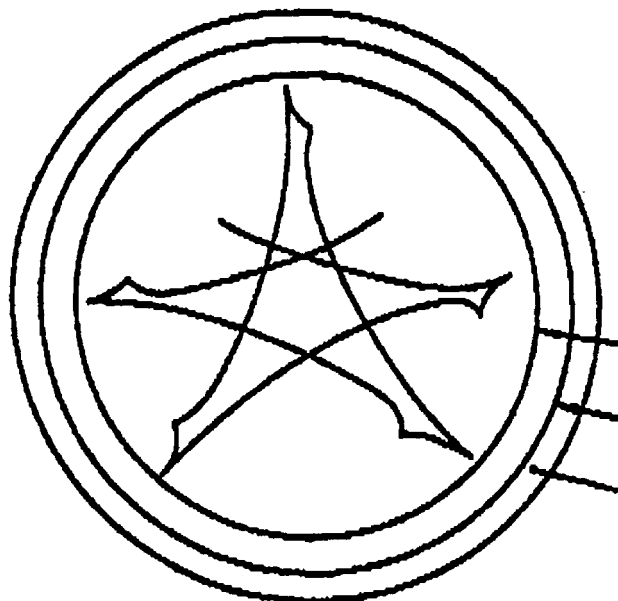

FIG. 2 Curved Pattern of a Castor Wheel

9.3.2 Use wood screws around the perimeter of the specimen at intervals of 75 ± 25 mm (3 ± 1 in.) to secure the specimen and underlayment, if used, to a plywood backing sheet. The screws are positioned outside of the annular wear area.

10. Procedure

10.1 Prior to each test, inspect the roller base assembly for signs of wear or damage. Confirm that the swivel and castors move freely when turned by hand without evidence of stiffness or looseness and the wheels are smooth and clean.

10.1.1 Replace worn or damaged castors with new, factory supplied equipment. If only the polyamide wheel is damaged, there is no need to replace the bearings. The castors should be expected to perform acceptably for up to 1 500 000 cycles with regular use.

10.1.2 For new chair castors or polyamide wheels, condition them on a pile yarn surface for a minimum of 25 000 cycles of rotation prior to testing.

10.1.3 Establish and follow a procedure to validate that the wear pattern is correct. Use carbonless paper applied to a backing sheet to imprint the wear pattern and compare against an established standard for the machine (see Fig. 2).

10.2 Prior to testing, vacuum the test specimen with an upright vacuum cleaner making four forward and backward passes making sure that all of the area has been covered.

10.3 Position the prepared test specimen on the base table such that the holes in the backing sheet fit over the stabilizing bolts.

10.4 Adjust the vacuum nozzle to a position between 5 and 10 mm (0.25 and 0.5 in.) above the yarn pile.

10.5 Close the protective cage and visually confirm that the limit switches are in position.

10.6 Set the counter endpoint to the total number of cycles of rotation required.

10.7 Check the vacuum filtration and empty or replace if filled and confirm vacuum operation.

10.8 Start the machine in automatic. It will automatically switch off when it completes the designated number of cycles of rotation.

10.9 Remove the test specimen and backing disk from the machine.

11. Report

11.1 State that the tester was operated as directed in Practice D 6962.

11.2 Report the following information:

11.2.1 The atmospheric conditions if other than standard,

11.2.2 All information necessary for complete identification of the test specimen,

11.2.3 Date of test,

11.2.4 The number of cycles of rotation,

11.2.5 Description and density of underlayment cushion, if used,

11.2.6 Description of adhesive, if used, and

11.2.7 Detail any deviations from this practice.

12. Keywords

12.1 carpet; castor chair tester; delamination; durability; pile yarn floor covering; roller chair tester; underlayment

ASTM International takes no position respecting the validity of any patent rights asserted in connection with any item mentioned in this standard. Users of this standard are expressly advised that determination of the validity of any such patent rights, and the risk of infringement of such rights, are entirely their own responsibility.

This standard is subject to revision at any time by the responsible technical committee and must be reviewed every five years and if not revised, either reapproved or withdrawn. Your comments are invited either for revision of this standard or for additional standards and should be addressed to ASTM International Headquarters. Your comments will receive careful consideration at a meeting of the responsible technical committee, which you may attend. If you feel that your comments have not received a fair hearing you should make your views known to the ASTM Committee on Standards, at the address shown below.

This standard is copyrighted by ASTM International, 100 Barr Harbor Drive, PO Box C700, West Conshohocken, PA 19428-2959, United States. Individual reprints (single or multiple copies) of this standard may be obtained by contacting ASTM at the above address or at 610-832-9585 (phone), 610-832-9555 (fax), or service@astm.org (e-mail); or through the ASTM website (www.astm.org).