



Designation: D 2582 – 003

Standard Test Method for Puncture-Propagation Tear Resistance of Plastic Film and Thin Sheeting¹

This standard is issued under the fixed designation D 2582; the number immediately following the designation indicates the year of original adoption or, in the case of revision, the year of last revision. A number in parentheses indicates the year of last reapproval. A superscript epsilon (ϵ) indicates an editorial change since the last revision or reapproval.

1. Scope*

1.1 This test method covers the determination of the dynamic tear resistance of plastic film and thin sheeting subjected to end-use snagging-type hazards.

1.2 The values stated in SI units are to be regarded as the standard. The values given in parentheses are for information only.

1.3 *This standard does not purport to address all of the safety concerns, if any, associated with its use. It is the responsibility of the user of this standard to establish appropriate safety and health practices and determine the applicability of regulatory limitations prior to use.*

NOTE 1—There is no equivalent ISO test method.

2. Referenced Documents

2.1 *ASTM Standards:*

¹ This test method is under the jurisdiction of ASTM Committee D20 on Plastics and is the direct responsibility of Subcommittee D20.19 on Film and Sheeting. Current edition approved April 10, 2000³. Published July 2000. April 2003. Originally published as D 2582 – 67; approved in 1967. Last previous edition approved in 2000 as D 2582 – 9300.

***A Summary of Changes section appears at the end of this standard.**

- D 618 Practice for Conditioning Plastics and Electrical Insulating Materials for Testing²
- D 883 Terminology Relating to Plastics²
- D 4000 Classification System for Specifying Plastic Materials³
- D 4805 Terminology for Plastics Standards⁴
- D 5947 Test Methods for Physical Dimensions of Solid Plastic Specimens⁵
- E 691 Practice for Conducting an Interlaboratory Study to Determine the Precision of a Test Method⁶

3. Terminology

3.1 Descriptions of Terms Specific to This Standard:

- 3.1.1 *slit tear*—a single tear parallel to the direction of the falling carriage.
- 3.1.2 *“V” tear*— a tear that has two individual tear legs (not necessarily of equal length) radiating approximately $\pm 45^\circ$ from the point the tear was initiated.

4. Significance and Use

4.1 The puncture-propagation of tear test measures the resistance of a material to snagging, or more precisely, to dynamic puncture and propagation of that puncture resulting in a tear. Failures due to snagging occur in a variety of end uses, including industrial bags, liners, and tarpaulins. The units reported in this test method are Newtons (tear resistance).

4.2 Experience has shown that for many materials puncture does not contribute significantly to the force value determined, due to the sharpness of the propagating probe used. However, comparing the results of prepunctured test specimens with normal nonpunctured specimens will give an indication of the extent of any puncture resistance in the reported result.

4.3 For many materials, there may be a specification that requires the use of this test method, but with some procedural modifications that take precedence when adhering to the specification. Therefore, it is advisable to refer to that material specification before using this test method. Table 1 of Classification System D 4000 lists the current ASTM materials standards.

5. Apparatus⁷

5.1 As shown in Fig. 1, the instrument consists of:

- 5.1.1 Carriages of different weight, each with a pointed probe. Each carriage weight shall have a tolerance of $\pm 1\%$ of the weight desired.
- 5.1.2 A test stand including:
 - 5.1.2.1 Carriage release mechanism,
 - 5.1.2.2 Scale marked in millimetres,
 - 5.1.2.3 Curved specimen holder with a tear slot and five clamps,
 - 5.1.2.4 Drop base with a guide channel to accommodate the carriage wheels, and
 - 5.1.2.5 Bubble level to level the base.

5.2 The standard drop height is 508 mm (20.0 in.); however, it can be varied to suit the desired end-use-rate condition. See 10.3 for an alternative method for calculating tear resistance for heights other than 508 mm.

5.3 The probe is a 3.18-mm (0.125-in.) diameter drill rod having one end a truncated cone, the short base 0.40 mm (0.016 in.) in diameter, with a 30° included angle so that most of the tear is propagated against the body of the rod. See Fig. 2.

5.4 *Thickness Gage*— a dead-weight micrometer as described in Test Method C of Test Method D 5947, or an equivalent measuring device, reading to 0.0025 mm (0.0001 in.) or less.

6. Test Specimen

6.1 Specimens can be cut in any rectangular shape so long as they are approximately 200 mm (8.0 in.) long in the direction of tear and can be held by all five clamps. Multiple tears can be made on a single sheet provided a minimum separation of 25 mm (1 in.) [1 in.] is maintained between tears.

6.2 Two sets of specimens shall be cut from each sample such that the direction of tear, during the test, will be parallel to (1) MD, the machine direction and (2) TD, the transverse direction, respectively, of the material being tested. Enough specimens shall be cut in each direction to provide for a minimum of five tears.

7. Preparation and Calibration of Apparatus

7.1 Level the base of the tester by centering the spirit level bubble by adjustment of the leveling legs.

² Annual Book of ASTM Standards, Vol 08.01.

³ Annual Book of ASTM Standards, Vol 08.02.

⁴ Discontinued; see 2002 Annual Book of ASTM Standards, Vol 08.03.

⁵ Annual Book of ASTM Standards, Vol 14.02: 08.03.

⁶ Supporting data are available from

⁶ Annual Book of ASTM Headquarters. Request RR- D20-H68, Standards, Vol 14.02.

⁷ The sole source of supply of the apparatus known to the committee at this time is **Testing Machines, Inc., 2910 Expressway Drive, South, Islandia, NY 11749**. If you are aware of alternative suppliers, please provide this information to ASTM International Headquarters. Your comments will receive careful consideration at a meeting of the responsible technical committee¹, which you may attend.

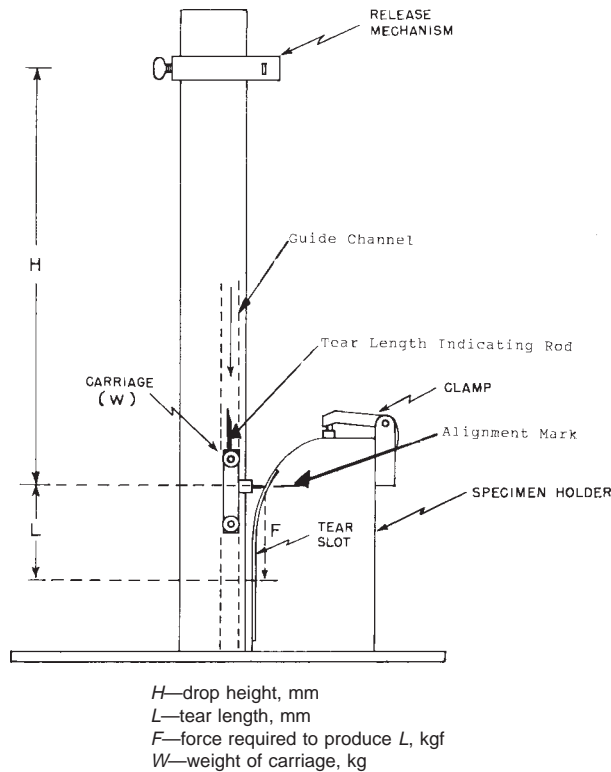

FIG. 1 Puncture-Propagation of Tear Tester

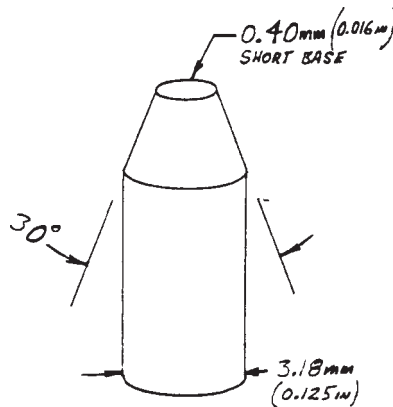

FIG. 2 Short Base Probe

7.2 Check “sharpness” of probes by visual observation under a magnifying glass. If the short base end is not 0.40 mm-([0.016 in.]) in diameter or any burrs, nicks, or distortions are noted, or both, replace the probe.

7.3 Check the length of the probes by inserting each carriage in turn in the guide channel and lowering to the alignment mark on the curved specimen holder. The point of the probe should be aligned with this mark.

7.4 Measure the vertical drop height from the specimen holder mark, located near the tear slot, to the horizontal mark on the carriage release mechanism. Adjust the selected height to the nearest 2 mm-([0.078 in.]). The standard drop height is 508 ± 2 mm.

7.5 Check the alignment of the specimen holder receiving slot by lowering a carriage with its probe extending into the slot, up and down the slot length. The probe should be centered, that is, not touching either edge of the slot.

8. Conditioning

8.1 *Conditioning*—Condition the test specimens at 23 ± 2°C-([73.4 ± 3.6°F]) and 50 ± 5 % relative humidity for not less than 40 hours prior to test in accordance with Procedure A of Practice D 618 for those tests where conditioning is required. In cases of disagreement, the tolerances shall be ±1°C-([±1.8°F]) and ±2 % relative humidity.

8.2 *Test Conditions*—Conduct tests in the standard laboratory atmosphere of 23 ± 2°C-([73.4 ± 3.6°F]) and 50 ± 5 % relative humidity, unless otherwise specified in the material specification. In cases of disagreement, the tolerances shall be ±1°C-([±1.8°F]) and ±2 % relative humidity.

9. Procedure

9.1 Measure and record the thickness of each specimen tested. Read the thickness to 0.0025 mm–([0.0001 in.]) or better, except for sheeting greater than 0.25 mm–([0.010 in.]), which shall be measured to a precision of 0.025 mm–([0.001 in.]) or better.

9.2 Secure the specimen in the holder by placing it under the clamps and setting the clamp lever to the down position. The specimen should drape against the holder contour. Stiffer materials should be loosely held adjacent to the holder. Each clamp should apply sufficient pressure to prevent any specimen slippage.

9.3 By trial and error, select the carriage that produces a minimum tear length of 40 mm and does not bottom-out against the drop base. Lower selected carriage until the probe point touches but does not indent the specimen. Adjust the tear length indicating rod to “0” on the scale located on the guide channel.

9.4 Place the selected carriage in the release mechanism.

9.5 Cock the release mechanism on the left side and release the carriage by pushing the button on the front of the release mechanism.

9.6 Read the tear length to the nearest 0.5 mm.

9.7 Raise the carriage by pulling the handle on the left side of the guide channel.

9.8 After the carriage has stopped its upward movement, relocate it in the release mechanism by pushing the carriage up in the guide channel by hand. (When the handle is released, the carriage-raising mechanism should return to the bottom of the guide channel. However, check before releasing the carriage for the next test.)

9.9 Re-cock the release mechanism.

9.10 Release the clamps and relocate the specimen for the next tear test cycle. Take care not to relocate the specimen so that the tears are too close to one another, thereby influencing the tear results.

9.11 Make a minimum of five determinations in each direction for each sample.

10. Calculation

10.1 Calculate the tear resistance, F , in Newtons, as follows:

$$F = [(W \times H)/L] + W(9.8065) \quad (1)$$

where:

W = weight of carriage, kg,

H = height of carriage before release, mm, and

L = length of tear, mm.

9.8065 = conversion factor for Newtons

See Appendix X1 for a derivation of the equation for tear resistance.

10.2 To determine the tear resistance employing a standard drop height of 508 ± 2 mm, use Table 1. (See X1.1.5 for an explanation of normalization).

10.3 To determine tear resistance employing a nonstandard drop height or carriage weight, other than those listed above, use the equation in X1.1.3 of Appendix X1.

10.3.1 For inter- and intralaboratory data comparisons, the same drop height and weight carriage must be used.

10.4 Calculate the average tear length, L , in both directions (MD and TD) to the nearest 0.1 mm.

10.5 Calculate the tear resistance, F , in each direction to the nearest 0.1 Newton.

10.6 Calculate the standard deviation (estimated) for each direction tested as follows:

$$s = \sqrt{(\sum X^2 - n\bar{X}^2)/(n - 1)} \quad (2)$$

where:

s = estimated standard deviation,

X = value of single observation,

n = number of observations, and

\bar{X} = arithmetic mean of the set of observations.

TABLE 1 Normalized Factors for Each Carriage Weight

Carriage No.	Carriage Weight		Factors
	kg \pm 1%	lb \pm 1%	
No. 1	0.1134	0.250	$F = (564.93/L) + 11.670$
No. 2	0.2268	0.500	$F = (1129.85/L) + 9.179$
No. 3	0.3402	0.750	$F = (1694.78/L) + 6.953$
No. 4	0.4536	1.00	$F = (2259.70/L) + 4.452$
No. 5	0.6804	1.50	$F = (3389.55/L) - 0.284$
No. 6	0.9072	2.00	$F = (4519.40/L) - 4.727$
No. 7	1.1340	2.50	$F = (5649.24/L) - 9.541$
No. 8	1.3608	3.00	$F = (6761.30/L) - 14.234$

11. Report

11.1 Report the following information:

- 11.1.1 Complete identification of the sample tested,
- 11.1.2 Average tear resistance for the direction tested,
- 11.1.3 Drop height selected, if nonstandard,
- 11.1.4 Carriage used,
- 11.1.5 Number of specimens tested, if greater or less than five,
- 11.1.6 Average thickness, in mils,
- 11.1.7 Type of tears produced, for example, “V” or slit, and
- 11.1.8 Standard deviation for each direction tested, reported to two significant digits.

12. Precision and Bias ⁸

12.1 Table 2 is based on a round robin conducted in 1990 in accordance with Practice E 691 involving eight materials tested in both MD and TD directions by six laboratories. All the samples were prepared at one source. Each test result was the average of five individual determinations. Each laboratory obtained two test results for each material.

~~NOTE 2—Caution: material. Warning—~~The following explanations of r and R (12.2-12.2.3) are only intended to present a meaningful way of considering the approximate precision of this test method. The data in Table 2 should not be rigorously applied to acceptance or rejection of material, as those data are specific to the round robin and may not be representative of other lots, conditions, materials, or between specific laboratories. Users of this test method should apply the principles outlined in Practice E 691 to generate data specific to their laboratory and materials, or between specific laboratories. The principles of 12.2-12.2.3 would then be valid for such data.

12.2 *Concept of r and R* —If S_r and S_R have been calculated from a large enough body of data, and from test results that were an average from testing five specimens:

12.2.1 *Repeatability Limit, r* (Comparing two test results for the same material, obtained by the same operator using the same equipment on the same day): The two test results should be judged not equivalent if they differ by more than the “ r ” value for that material.

$$r = 2.83 S_r$$

12.2.2 *Reproducibility Limit, R* (Comparing two test results for the same material, obtained by different operators using different equipment in different laboratories): The two test results should be judged not equivalent if they differ by more than the “ R ” value for that material.

$$R = 2.83 S_R$$

12.2.3 Any judgment in accordance with 12.2.1 and 12.2.2 would have an approximate 95 % (.95) probability of being correct.

12.3 *Bias*—There are no recognized standards by which to estimate bias of this test method.

13. Keywords

13.1 plastic film; plastic sheeting; puncture propagation; slit tear; snagging; tear resistance; “V” tear

⁸ Supporting data are available from ASTM Headquarters. Request RR: D20-1168.

TABLE 2 Precision and Bias^A

Material	Thickness		AVG	S_r	S_R^B	r^B	R^C	
	mm	mils						
PE/EVA	MD	0.05	2	21.6	0.6	0.7	1.6	1.9
PE/EVA	TD	0.05	2	40.5	1.1	4.0	3.0	11.1
PP	MD	0.1	4	49.9	1.1	2.6	3.0	7.2
PP	TD	0.1	4	59.5	1.3	4.5	3.7	12.6
PE	MD	0.08	3	61.5	1.1	3.2	3.2	9.1
PE	TD	0.08	3	67.4	1.2	5.3	3.3	14.7
PETG	MD	0.23	9	67.4	3.5	6.2	9.81	17.4
PETG	TD	0.23	9	76.2	4.9	9.2	3.8	25.8
PE	MD	0.2	8	74.9	2.0	9.1	5.6	25.6
PE	TD	0.2	8	81.2	2.0	8.1	5.5	22.7
LLPE	MD	0.13	5	79.4	1.5	4.6	4.3	12.9
LLPE	TD	0.13	5	85.9	1.5	7.6	4.1	21.4
PE	MD	0.15	6	93.5	2.8	9.9	7.9	27.7
PE	TD	0.15	6	97.1	2.4	8.8	6.6	24.7
LLPE	MD	0.25	10	136.5	1.6	9.31	4.6	26.2
LLPE	TD	0.25	10	134.2	2.2	4.0	6.0	39.1

^A Values expressed in Newtons

^B $r = 2.83 \times S_r$

^C $R = 2.83 \times S_R$

APPENDIX

(Nonmandatory Information)

X1. DERIVATION OF EQUATION FOR TEAR RESISTANCE

X1.1 The equation for determining average tear resistance (effective force to tear) has been derived for a drop height of 508 mm (20.0 in.) as follows:

X1.1.1 Potential energy of carriage before release = $W(H + L)$ = work done on sample in bringing carriage to a stop, where: W = weight of the carriage, H = height of carriage before release, and L = length of tear.

X1.1.2 Work done on sample = effective force exerted by probe in propagating tear (= tear resistance) \times length of tear = $F \times L$, where: F = effective force exerted by probe and L = length of tear.

X1.1.3 Equating the two, $W(H + L) = F \times L$, so that: tear resistance (in Newtons), $F = [(W \times H)/L] + W$ 9.8065.

NOTE X1.1—The preceding equation is to be used for nonstandard drop height tests.

X1.1.4 The following approximations were made in deriving this equation: tear resistance was assumed proportional to deceleration of the carriage, and the angle at which the probe punctured the sample was neglected.

X1.1.5 In order to compare results of tests performed using different weight carriages, at the standard drop height of 508 mm, an adjustment has been incorporated in the calculation to compensate for the small increase in tear resistance found when the carriage weight is increased (see Fig. X1.1). To prevent reporting significantly different values due to the use of different carriages, these test results are normalized in terms of the 0.46-kg (1-lb) carriage by: (1) plotting tear resistance (Y -axis) versus weight of carriage (X -axis) for a variety of different type flexible materials, (2) determining the slope of best fit from the slope determined by testing each material at two or more carriage weights, (3) drawing an X -axis through the Y -axis for the 0.46-kg carriage at the point of interception of the slope, and (4) adding a force (in Newtons) increment to the calculated tear resistance where the slope intercepted a Y -axis for a lighter weight carriage below the X -axis and subtracting when it intercepted a Y -axis for a heavy weight carriage above the X -axis.

X1.1.6 For tests conducted at nonstandard drop heights, use the equation in X1.1.3. Results can be compared only if the same carriage weight and drop height are employed.

SUMMARY OF CHANGES

This section identifies the location of selected changes to this test method. For the convenience of the user, Committee D20 has highlighted those changes that may impact the use of this test method. This section may include descriptions of the changes or the reasons for the changes, or both.

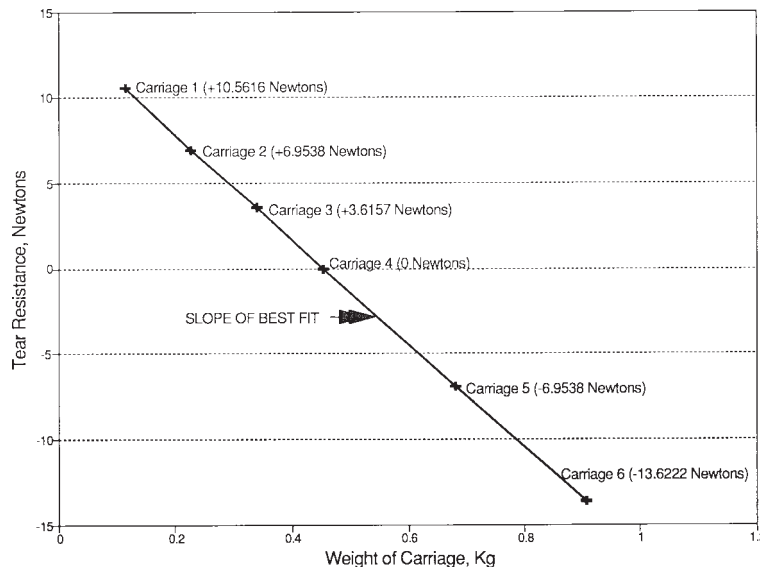

Note: Graph is in terms of a 0.46 Kg carriage for a drop of 508 mm.

FIG. X1.1 Normalization of Tear Resistance

D 2582 - 03:

(1) Added a sole source for the apparatus in Section 5.

D 2582 - 00:

- (1) An ISO equivalency statement has been added.
- (2) A reference for the micrometer to be used was added to the apparatus section.
- (3) Several minor editorial changes were made in various sections.

ASTM International takes no position respecting the validity of any patent rights asserted in connection with any item mentioned in this standard. Users of this standard are expressly advised that determination of the validity of any such patent rights, and the risk of infringement of such rights, are entirely their own responsibility.

This standard is subject to revision at any time by the responsible technical committee and must be reviewed every five years and if not revised, either reapproved or withdrawn. Your comments are invited either for revision of this standard or for additional standards and should be addressed to ASTM International Headquarters. Your comments will receive careful consideration at a meeting of the responsible technical committee, which you may attend. If you feel that your comments have not received a fair hearing you should make your views known to the ASTM Committee on Standards, at the address shown below.

This standard is copyrighted by ASTM International, 100 Barr Harbor Drive, PO Box C700, West Conshohocken, PA 19428-2959, United States. Individual reprints (single or multiple copies) of this standard may be obtained by contacting ASTM at the above address or at 610-832-9585 (phone), 610-832-9555 (fax), or service@astm.org (e-mail); or through the ASTM website (www.astm.org).