



Designation: D 6049 – 023

Standard Test Method for Rubber Property—Measurement of the Viscous and Elastic Behavior of Unvulcanized Raw Rubbers and Rubber Compounds by Compression Between Parallel Plates¹

This standard is issued under the fixed designation D 6049; the number immediately following the designation indicates the year of original adoption or, in the case of revision, the year of last revision. A number in parentheses indicates the year of last reapproval. A superscript epsilon (ϵ) indicates an editorial change since the last revision or reapproval.

1. Scope

1.1 This test method is an adaptation of the German Standard DIN 53514, a further development of the former “Defo Test” (see Appendix X1).

1.2 This test method is capable of measuring and characterizing the rheological behavior (viscosity and elasticity) of unvulcanized raw rubbers and rubber compounds, relating to the macro structure of rubber polymers (average molecular weight, molecular weight distribution, long chain branching, and micro- and macro-gel).

1.3 The viscosity and elasticity of unvulcanized rubbers and rubber compounds are determined by subjecting cylindrical test pieces to a compression/recovery cycle. The dependency on shear rate at constant shear stress is evaluated and the material fatigue behavior is determined in repeat cycle testing.

1.4 The non-Newtonian viscous and elastic behavior of rubbers and rubber compounds can also be evaluated.

1.5 Statistical evaluation of the test data provides an indication of data variation, which may be employed as an estimate of the homogeneity of the material tested.

1.6 The values stated in SI units are to be regarded as the standard. The values in parentheses are for information only.

1.7 *This standard does not purport to address all of the safety concerns, if any, associated with its use. It is the responsibility of the user of this standard to establish appropriate safety and health practices and determine the applicability of regulatory limitations prior to use.*

2. Referenced Documents

2.1 *ASTM Standards:*

¹ This test method is under the jurisdiction of Committee D11 on Rubber and is the direct responsibility of Subcommittee D11.12 on Processability Tests.

Current edition approved Dec. 10, 2002. Published January 2003. Originally approved in 1996. Last previous edition approved in 1996 as D 6049 – 96-02.

D 297 Test Methods for Rubber Products—Chemical Analysis²

D 926 Test Method for Rubber Property—Plasticity and Recovery (Parallel Plate Method)²

D 4483 Practice for Determining Precision for Test Method Standards in the Rubber and Carbon Black Industries²

D 6048 Practice for Stress Relaxation Testing of Raw Rubber, Unvulcanized Rubber Compounds, and Thermoplastic Elastomers²

2.2 DIN Standards:

DIN 53514 Testing of Rubber—Determination of Viscosity and Elasticity Related Numbers of Raw Rubber and Rubber Mixes in a Compression Test between Parallel Plates³

DIN 53523, Part 1 Testing of Rubber and Elastomers—Testing with the Mooney Shearing Disk Viscometer; Preparation of Test Pieces³

2.3 ISO Standards:

ISO 5725 Precision of Test Methods—Determination of Repeatability and Reproducibility for a Standard Test Method by Interlaboratory Tests⁴

ISO 7323 Rubber—Raw and Unvulcanized Compounded—Determination of Plasticity Number and Recovery Number; Parallel Plate Method⁴

3. Terminology

3.1 *Definitions*—The following terms appear in logical order for the sake of clarity.

3.1.1 *Multiple Compression Force Test*—refer to Section 10 for more details.

3.1.1.1 *viscosity number*, V_{10} (Ns)—the product of the force F in N required to compress a test piece the final 0.5 mm (0.02 in.) in a 6.0 mm (0.24 in.) total compression cycle (from 13.0 to 7.0 mm (0.51 to 0.28 in.)) and the compression time dt_1 equaling 10 s.

3.1.1.2 *total compression time*, t_T —the time in s required to compress a test piece the full 6.0 mm (0.24 in.), that is, from 13.0 to 7.0 mm (0.51 to 0.28 in.).

3.1.1.3 *elasticity number*, DE_{30} —the elastic recovery expressed in units of 0.1 mm (0.004 in.) calculated from the height h_2 of the test piece after compression from 13.0 to 7.0 mm (0.51 in. to 0.28 in.) within 30 s followed by a recovery period of 30 s.

3.1.1.4 *non-Newtonian viscosity exponent*, n_1 —the slope of the line in a double log plot of the viscosity versus the shear rate; n_1 is dimensionless and always negative.

3.1.1.5 *elasticity coefficient*, m —the slope of the line in a plot of the elasticity number DE (see 3.1.2.3) versus the log of the shear rate; the dimension of m is mm (in units of 0.1 mm per decade).

3.1.1.6 *test data variation number*, s_v —the average standard deviation of the data points of the individual test pieces, from the regression line of the viscosity number in accordance with 3.1.1.4.

3.1.1.7 *test data variation number*, s_e —the average standard deviation of the data points of the individual test pieces from the regression line of the elasticity number in accordance with 3.1.1.5.

(a) *Discussion* —Both numbers, s_v and s_e , can be used to (1) characterize the homogeneity of the test pieces or (2) provide an estimate of the test precision where test pieces are known to be homogeneous. In addition, s_e can indicate rare cases of nonlinearity.

3.1.1.8 *viscous material fatigue*, ΔV_{21} —the decrease in percent of V_{10} for the first compression compared to V_{10} for the second compression.

(a) *Discussion* —When the first compression/recovery cycle (compression time = recovery time) is repeated, the viscosity number of the second cycle will be lower than that of the first cycle.

3.1.1.9 *elastic material fatigue*, Q_{21} —the quotient of the recovery times, $(t_{RV})_2$ and $(t_{RV})_1$, after the second and first compression/recovery cycle, allowing the test piece to reach equivalent recovery heights in both cycles; Q_{21} is dimensionless.

(a) *Discussion* —In the second compression/recovery cycle the test piece requires a longer recovery time to reach the same height as in the first cycle.

3.1.2 *Single Compression Force Test*—refer to Section 10 for more details.

3.1.2.1 *viscosity*—specific to this test method, the ratio of compression force to compression time, where compression force and compression time are proportional to shear stress and shear rate, respectively.

(a) *Discussion* —The compression force F specified for a particular material determines the deformation stress, and the compression time dt_1 required to compress a test piece the final 0.5 mm (0.02 in.) in a 6.0 mm (0.24 in.) total compression cycle (from 13.0 to 7.0 mm (0.51 to 0.28 in.)) determines the deformation rate.

3.1.2.2 *total compression time*, t_T —refer to 3.1.1.2.

3.1.2.3 *elastic recovery*, DE —calculated from the height h_2 of the test piece after compression from 13.0 to 7.0 mm (0.51 in. to 0.28 in.) followed by a recovery period, equal in length to the compression time, expressed in units of 0.1 mm (0.004 in.).

² Annual Book of ASTM Standards, Vol 09.01.

³ Available from Deutsches Institut für Normung, Burggrafenstr 6, D 10787 Berlin 30, Germany.

⁴ Available from American National Standards Institute (ANSI), 25 W. 43rd St., 4th Floor, New York, NY 10036.

3.1.2.4 *non-Newtonian viscosity number*, q —the quotient of the two compression time values dt_1 and t_7 (see 3.1.2.1 and 3.1.1.2); q is dimensionless.

3.1.2.5 *test data variation*—the standard deviations s_c for the compression time dt_1 (3.1.2.1) and s_r for the elastic recovery DE (3.1.2.3).

(a) *Discussion* —see 3.1.1.7.

3.1.2.6 *viscous material fatigue*, Δdt_{21} —the decrease in percent of the compression time dt_2 versus the compression time dt_1 .

(a) *Discussion* —When the first compression/recovery cycle (compression time = recovery time) is repeated with the same force, the compression time dt_2 of the second cycle will be lower than the compression time dt_1 of the first cycle.

4. Summary of Test Method

4.1 This test method provides procedures for preparing cylindrical test pieces of specified diameter and height from unvulcanized raw rubbers and rubber compounds and for testing their viscous and elastic behavior at a specified temperature in a compression/recovery operation between parallel plates.

4.2 The compression device is mounted in an environmental chamber. The preferred test temperature is 105°C (221°F).

4.3 The change in test piece height is measured under a constant compression force and in the recovery phase after releasing the force.

4.4 Viscosity is characterized by compression force and compression time, elasticity by the recovery height of the test piece after release of the compression force (recovery phase). Material fatigue is measured through repeat compression/recovery cycles.

4.5 The test can be performed with multiple compression forces for a more comprehensive evaluation of the viscous and elastic properties, including non-Newtonian behavior, or with a time saving single compression force, preferred in quality control to test primarily uniformity of viscosity and elasticity.

4.6 Statistical evaluation of the test results gives an indication of data scatter, and permits also an assessment of the homogeneity of the material under test.

5. Significance and Use

5.1 The viscous and elastic behavior of unvulcanized rubbers and rubber compounds is of paramount importance in rubber manufacturing, since it affects processing, such as mixing, calendaring, extrusion, and molding. The uniformity of these properties is equally important, as fluctuations will cause upsets in manufacturing processes.

5.2 A test capable of measuring viscosity and elasticity of unvulcanized rubbers and rubber compounds, including their uniformity and prediction of processing behavior, is therefore highly desirable (see Practice D 6048 for further information).

5.3 Compared to many other rheological tests, this test method measures viscosity and elasticity related parameters under conditions of low shear and has a high discriminating power. It can detect small rheological differences. A full discussion of the principles behind stress relaxation testing is given in Practice D 6048.

5.4 Test results of this test method may be useful in predicting processability, but correlation with actual manufacturing processes must be established in each individual case, since conditions vary too widely.

5.5 This test method is suitable for specification compliance testing, quality control, referee purposes, and research and development work.

6. Interferences

6.1 For reliable test results it is important that test pieces are of accurate dimensions, are free of air inclusions and blisters, and contain negligible residual stresses.

6.2 Although this test method is practically unlimited in testing unvulcanized rubbers, it may be necessary to consider smaller test pieces in the case of very hard and rigid substances.

7. Apparatus⁵

7.1 *Compression Device:*

7.1.1 Two circular platens with a diameter of 30.0 ± 0.1 mm (1.181 ± 0.004 in.) and a thickness of at least 2 mm (0.08 in.) mounted in an angle iron frame, are facing each other horizontally. The upper platen can be vertically moved and raised at least 14 mm (0.55 in.) above the lower platen to permit insertion of the 13-mm (0.51-in.) high test piece.

7.1.2 The upper platen shall be able to move nearly without friction, that is, it must smoothly descend under the contact force specified in 7.1.5.

7.1.3 The upper platen shall be capable of applying a compressive force between 1 and 800 N (0.22 and 180 lbf) ± 0.5 % to the test piece within 1 s. The force should be applied rapidly but not abruptly.

7.1.4 After the height of the test piece has been reduced from 13.0 to 7.0 mm (0.51 to 0.28 in.) the compression force shall be released in less than 0.5 s.

⁵ A suitable instrument can be obtained under the name Defo-Elastometer (System Bayer) from Haake, Inc., West Century Road, Paramus, NJ 07652, or Haake G.m.b.H., Dieselstr., D76227 Karlsruhe, Germany.

7.1.5 A residual compression force of 0.040 ± 0.005 N (0.009 ± 0.001 lbf) shall always be maintained by the upper platen to warrant an intimate contact with the test piece prior to compression and during the recovery cycle. The mass of the upper platen must be taken into account and compensated for.

7.1.6 The position of the upper platen shall be continuously recorded during the test to the nearest 0.01 mm (0.0004 in.) in at least 0.05 s intervals. The starting time of the compression cycle, the time of reaching compression heights of 7.5 and 7.0 mm (0.30 and 0.28 in.), and the recovery times shall be recorded to the nearest 0.05 s.

7.1.7 The compressed test pieces shall only be in contact with the two platens and the platens shall be kept free of contamination. The test piece arrangement is illustrated in Fig. 1.

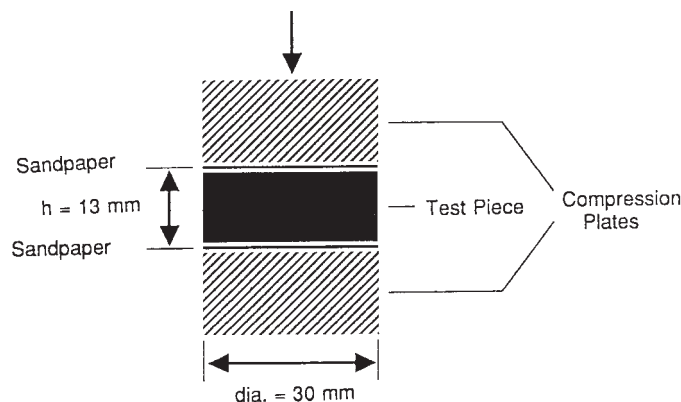

FIG. 1 Test Piece Arrangement

7.2 Test Chamber:

7.2.1 The compression device shall be contained in a test chamber that can be temperature controlled between 20 and 170 ± 1°C (68 and 338 ± 2°F).

7.2.2 The test chamber shall have holding devices to accommodate test pieces of 13.0 ± 0.1 mm (0.51 ± 0.004 in.) plus twice the thickness of the sandpaper in height for conditioning.

7.3 Recording and Evaluation of Test Results:

7.3.1 The test shall be run and controlled automatically, including recording of the compression heights and times.

7.3.2 Evaluation of test results is best carried out immediately after the test. The use of a computer to control the test sequence and record data is recommended.

8. Preparation of Test Pieces

8.1 The cylindrical test piece shall have a height of 13.0 ± 0.1 mm (0.51 ± 0.004 in.) and a diameter of 30.0 ± 0.1 mm (1.18 ± 0.004 in.). It is typically produced by molding and should be free of blisters and internal residual stresses. Sandpaper disks⁶ shall be molded to the top and bottom of the cylindrical test piece to stabilize the surfaces and ensure an even transmission of the compression forces without slippage. The sandpaper facing also prevents fouling of the platens of the compression device and can be used for identification purposes.

8.2 Test Pieces from Rubber in Bale Form:

8.2.1 Sheets of approximately 2 mm (0.08 in.) in thickness are sliced from the bale, and disks of approximately 30 mm (1.18 in.) in diameter are die cut from these sheets. The disks are loosely plied up to produce a specimen sufficiently large in volume for a test piece, including a mold flash of 0.05 to 0.35 g.

8.2.2 The mass of material required for a test piece can be derived from the density of the material and the test piece volume of approximately 9.2 cm³ (0.56 in.³) (mass = volume × density). It is also necessary to consider the sandpaper with a density of approximately 1.28 g/cm³ (for two disks per test piece a mass of 0.34 g and a thickness of 0.38 mm is typical).

8.2.3 The test specimen is weighed to the nearest 0.1 g and placed into a “ring-and-piston” type compression mold, covering the top and bottom surfaces of the sample with approximately 30 mm (1.18 in.) diameter sandpaper disks. The grain of the sandpaper is facing the sample.

8.2.4 The test specimen is then molded into a test piece by compression under vacuum (DIN 53523, Part 1). The equipment is comprised of a laboratory press with a vacuum pump, vacuum connection, and a rubber seal ring, accommodating several molds at the same time. The molding temperature shall be identical to the test temperature and the pressure should be sufficiently high to ensure adequate compaction and blister-free test pieces. This can be judged by the amount of flash produced, or if in doubt, the density may be determined in accordance with Test Methods D 297, Paragraph 16.3, Hydrostatic Method.

⁶ A suitable sandpaper is 3M 230N (120 grit, aluminum oxide) available from 3M Abrasive Systems Div., 3M Center, St. Paul, MN 55144, or 3M 204 (120 grit, aluminum oxide) available from Fa. Krueckemeyer, D57225 Wilmsdorf, Germany.

8.2.5 The heating and vacuum phase of the molding process takes about 10 to 15 min, followed by about 10 min compression time under vacuum. Longer times may be necessary for high molecular weight materials, such as natural rubber, to obtain stable test pieces after removal from the mold.

8.2.6 After the molding process, test pieces are deflashed and immediately transferred into the preheated test chamber for conditioning until they are tested. If blisters appear (for example, in very soft materials) the procedure described in 8.3 shall be followed.

8.3 Test Pieces from Rubber in Chip Form:

8.3.1 The chips are cut into cubes of approximately 5 mm (0.2 in.) in length and then the procedure described in 8.2 shall be followed to prepare the test piece.

8.3.2 If blisters appear, the material shall be preheated in the compression ring of the mold for 10 min under vacuum without lowering the piston.

8.4 Test Pieces from Rubber in Crumb or Powder Form:

8.4.1 The procedure described in Section 8.2 shall be followed to prepare test pieces directly from the crumb or powder.

8.5 Test Pieces from Rubber Compounds (see Note 1):

8.5.1 For “nonproductive” compounds (without curatives) an approximately 30 mm (1.18 in.) diameter disk is die cut from a 13 to 14 mm (0.51 to 0.55 in.) thick sheet and the test piece is then prepared following the procedure described in 8.2.

8.5.2 For “productive” compounds (containing curatives) use sheets of 4.5 to 5.0 mm (0.18 to 0.20 in.) thickness. Three disks, each $3.0 \pm 0.1 \text{ cm}^3$ ($0.18 \pm 0.006 \text{ in.}^3$) in volume, are die cut from the sheet using a constant volume punch⁷ and pressed for 2 min in a simple platen arrangement with 4.5 to 5.0 mm (0.18 to 0.20 in.) spacer bars (see Note 2) at the test temperature. The three disks are then plied up, sandwiched between two sandpaper disks and pressed for another 2 min at the test temperature to form the test piece as described in 8.2. The test pieces are then transferred into the test chamber and tested immediately.

NOTE 1—It is important that each test piece is made up of representative and uniform material, that is, several samples must be taken from different locations of a larger sample (sheet) or the total batch, and homogenized on a rubber mill under suitably defined conditions to form the sheet for test piece preparation.

NOTE 2—A compression set apparatus with 4.5 to 5.0 mm (0.18 to 0.20 in.) spacers is a suitable set-up.

9. Procedure

9.1 The recommended test temperature is $105 \pm 1^\circ\text{C}$ ($221 \pm 2^\circ\text{F}$), but other temperatures may be employed if desired (Note 3).

NOTE 3—A temperature of 105°C (221°F) for the preparation, conditioning, and testing of test pieces is preferred over lower temperatures, since it more effectively eliminates volatiles, including moisture, from the test pieces.

9.2 Do not test test pieces unless they have been conditioned in the test chamber for at least 10 min, with the exception of “productive” compounds as described in 8.5.2. Run the test with the individual test pieces centered between the parallel plates. After completion of the test, cool the test pieces to room temperature and weigh to the nearest 0.1 g as a cross-check.

9.3 Multiple Compression Force Test:

9.3.1 The force chosen to compress the test piece by 6.0 mm (0.24 in.), from 13.0 to 7.0 mm (0.51 to 0.28 in.), shall yield a total compression time t_T between 10 and 80 s. Starting points are approximately 40 N (9.0 lbf) for low viscosity, 100 N (22.5 lbf) for medium viscosity, and 160 N (36.0 lbf) for high viscosity materials. Run at least three and preferably five different compression forces within the 10 to 80 s compression time range. One test piece for each compressive force is normally sufficient.

9.3.2 The principle of the test is shown in Fig. 2. Compress the test piece under a constant force to a height of 7.0 mm (0.28 in.); release the force and allow the test piece to recover for a time period that equals the compression time. The height of the test piece after the recovery is h_2 .

9.3.3 A second compression cycle immediately follows the first, using the same force to compress the test piece to a height of 7.0 mm (0.28 in.). The recovery time necessary for the test piece to reach the same height, h_2 , as in the first test is determined.

9.3.4 The following test results are recorded for each test piece:

9.3.4.1 t_T —total compression time in s for the first compression cycle.

9.3.4.2 dt_1 —compression time in s to reduce the test piece height from 7.5 to 7.0 mm (0.30 to 0.28 in.) in the first compression cycle.

9.3.4.3 h_2 —Test piece height in units of 0.1 mm (0.004 in.) for the first recovery cycle. The recovery time is $(t_{RV})_1 = t_T$.

9.3.4.4 dt_2 —compression time in s to reduce the test piece height from 7.5 to 7.0 mm (0.30 to 0.28 in.) in the second compression cycle.

9.3.4.5 $(t_{RV})_2$ —time in s for the second recovery cycle, allowing the test piece to regain the height h_2 .

9.3.4.6 F —adjusted compression force in N.

9.4 Single Compression Force Test :

9.4.1 Testing is carried out in accordance with 9.3, usually omitting the second compression cycle.

⁷ A suitable volume punch can be obtained under Catalog No. 83.00 (manual) or Catalog No. 89.00 (air operated) from Goettfert, 488 Lakeshore Parkway, Rockhill, SC 29730, or Goettfert Werkstoff-Pruefmaschinen G.m.b.H., Postfach 1261, D74711 Buchen, Germany.

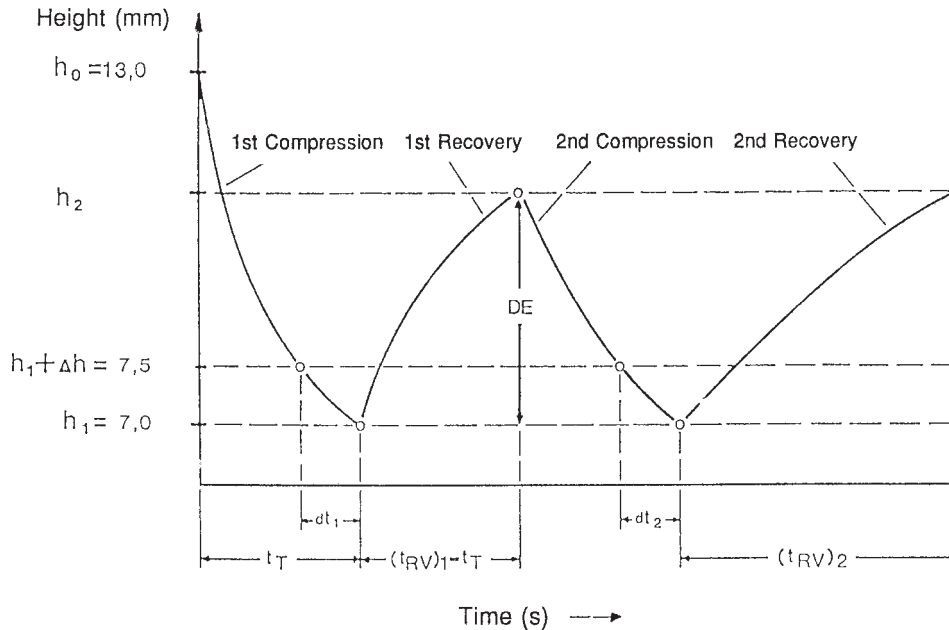

FIG. 2 Principle of Compression/Recovery Cycle

9.4.2 For quality control testing, where the uniformity of rubbers and rubber compounds is of main concern, the shorter single compression force test may be employed. The appropriate force must be determined by pre-testing to yield compression times for dt_1 between 8 and 16 s.

9.4.3 Testing of a single test piece is normally sufficient. For referee purposes, testing of three pieces is recommended.

10. Calculation and Interpretation of Results

10.1 *Multiple Compression Force Test* (see Note 4):

10.1.1 *Viscosity:*

10.1.1.1 Rubbers and rubber compounds exhibit a non-Newtonian behavior, that is, the viscosity decreases with increasing shear rate. This behavior is described by the Ostwald-deWaele model, stating that the double log plot of viscosity versus shear rate yields a straight line with a negative slope. In the final phase of the compression cycle the shear rate is $\gamma \propto 1/dt_1$.

10.1.1.2 Since the shear stress is proportional to the compression force F , it follows that the viscosity is also proportional to the compression force:

$$\text{Viscosity} = \frac{\text{shear stress}}{\text{shear rate}} \propto \frac{F}{1/dt_1} = F \times dt_1 \tag{1}$$

The product $F \times dt_1$ is referred to as the viscosity number with the dimension Ns. For the case of $dt_1 = 10$ s the viscosity number is V_{10} .

$$V_{10} = F \times 10 \tag{2}$$

10.1.1.3 Linear regression analysis of $\log (F \times dt_1)$ versus $\log (1/dt_1)$ permits determination of the two parameters characterizing the straight line, that is, V_{10} identifying the position of the line (viscosity level) and the slope given by the dimensionless non-Newtonian viscosity exponent:

$$n_1 = \frac{\Delta \log (F \times dt_1)}{\Delta \log (1/dt_1)} \tag{3}$$

10.1.1.4 Regression analysis also makes it possible to determine the average standard deviation s_v of the individual data points from the line, reported as the average coefficient of variation in percent.

10.1.1.5 Test results of the second compression cycle can be treated in the same manner to produce $(V_{10})_2$ and n_2 . The value of n_2 can serve as a cross-check for n_1 , while $(V_{10})_2$ is used to calculate the viscous material fatigue in percent:

$$\Delta V_{21} = 100 \times \frac{[(V_{10})_2 - V_{10}]}{V_{10}} \tag{4}$$

10.1.2 *Elasticity:*

10.1.2.1 Elasticity is reported as the elastic recovery DE in units of 0.1 mm and is determined by measuring the test piece height h_2 after a recovery time that equals the compression time t_T (see Fig. 2). The recovery is $(h_2 - 7)$ mm (since 7 mm is the final compression height) and the elastic recovery in mm is calculated as:

$$DE = \frac{(h_2 - 7)}{0.1} \quad (5)$$

The elastic recovery for the case of $t_T = 30$ s is referred to as elasticity number DE_{30} .

10.1.2.2 The shear rate dependency of t_T can be represented by a plot of DE versus $\log(1/t_T)$ producing a straight line. Linear regression analysis allows determination of the two parameters characterizing this line, that is, DE_{30} identifying its position (elasticity level) and the slope given by the elasticity coefficient in units of 0.1 mm per decade:

$$m = \frac{\Delta DE}{\Delta \log(1/t_T)} \quad (6)$$

10.1.2.3 Regression analysis also makes it possible to determine the average standard deviation s_e of the individual data points from the straight line. In this case, s_e is reported in DE units of 0.1 mm.

10.1.2.4 From test results of the second compression cycle, the (dimensionless) elastic material fatigue Q_{21} can be calculated from the two recovery times as follows (see Fig. 2):

$$Q_{21} = \frac{(t_{RV})_2}{(t_{RV})_1} \quad (7)$$

10.2 *Single Compression Force Test* (see Note 4):

10.2.1 *Viscosity:*

10.2.1.1 The viscosity V is characterized by the compression time dt_1 in s for the final compression phase from 7.5 to 7.0 mm test piece height and the specified compression force F in N.

10.2.1.2 The (dimensionless) non-Newtonian viscosity number q is calculated from the two compression time values dt_1 and t_T in accordance with the following:

$$q = \frac{dt_1}{t_T} \quad (8)$$

10.2.1.3 A second compression cycle permits the calculation of the viscous material fatigue Δdt_{21} from the two compression times dt_2 and dt_1 in percent in accordance with the following:

$$\Delta dt_{21} = 100 \times \frac{(dt_2 - dt_1)}{dt_1} \quad (9)$$

10.2.2 *Elasticity:*

10.2.2.1 Elasticity is calculated and reported as described in 10.1.2.1.

10.2.2.2 If two compression cycles are carried out, the elastic material fatigue can be calculated in accordance with 10.1.2.4.

NOTE 4—When several test pieces are evaluated, each piece should be tested individually for the described parameters and the median should be reported as the test result. In addition, the standard deviations $s(dt_1)$ and $s(DE)$ also should be calculated.

11. Report

11.1 Report the following information:

11.1.1 ASTM designation and year of issue,

11.1.2 Description of the material and its origin,

11.1.3 Date and temperature of testing, T in °C,

11.1.4 Method of test piece preparation with reference to the section of this test method,

11.1.5 Number of test pieces evaluated for each material,

11.1.6 Procedure used (multiple/single compression force, single/repeat compression cycle),

11.1.7 All test results of Section 10, including test data variation (standard deviations), and

11.1.8 Any procedural deviations from standard test methods.

11.2 For the multiple compression force test, report the following additional information:

11.2.1 Average mass, G , of the test pieces (arithmetic mean),

11.2.2 Range of t_T values, and

11.2.3 Range of the compression forces, F .

11.3 For the single compression force test, report the following additional information:

11.3.1 Mass, G , of the test piece (where applicable the arithmetic mean), and

11.3.2 Compression force, F .

11.4 Test results shall be rounded to the following accuracy:

11.4.1 F to the nearest 0.5 % (the instrument shall be calibrated to an accuracy of ± 0.5 %),

11.4.2 V_{10} to the nearest 1.0 %,

11.4.3 DE , DE_{30} , t_T , $d t_1$, m , V_{21} , Q_{21} , dt_{21} , s_v , s_e , $s(dt_1)$, $s(DE)$, T , and G to one decimal point, and

11.4.4 n_1 , q to three decimal points.

12. Precision and Bias ⁸

12.1 This precision and bias section deals with test results obtained in a single compression force test program organized in accordance with ISO 5725. This section has been prepared in accordance with Practice D 4483, which is equivalent to ISO 5725. Refer to this practice for terminology and other statistical calculation details.

12.2 The precision results in this section give an estimate of the precision of this test method with the materials used in the particular interlaboratory test program as described in 12.3. The precision parameters should not be used for acceptance or rejection testing of any group of materials without documentation that the parameters are applicable to the group of materials and the specific testing protocols of the test method.

12.3 A Type 1 interlaboratory test program was conducted in 1992 using six different raw unvulcanized rubbers and involving six European laboratories. Testing was carried out in accordance with the single compression force procedure at a test temperature of 105°C (221°F). The rubber samples were distributed from one location and each laboratory prepared the necessary test pieces from the raw rubbers. A test result (as used for these calculations) is the median of three test pieces, as specified for the single compression force test. Each laboratory conducted tests on each of three days, separated by nine and another seven days. Both repeatability and reproducibility are therefore medium term. The results of the precision evaluation are given in Table 1.

12.4 The precision is given in terms of Sr , r , (r), SR , R and (R) for four measured properties: (1) compression time, dt_1 ; (2) elastic recovery, DE ; (3) non-Newtonian viscosity number, q ; and (4) viscous material fatigue, Δdt_{21} , of the test pieces.

12.5 The precision of the test method may be expressed in the format of the following statements which use an “appropriate value” of r , R , (r) or (R), that is, that value to be used in decisions about test results obtained with this test method. The “appropriate value” is that value of r or R associated with the mean level in Table 1 closest to the mean level under consideration (at any given time, for any given material) in routine testing operations.

12.6 *Repeatability*— The repeatability, r , of this test method has been established as the appropriate value tabulated in Table 1. Two single test results, obtained under normal test method procedures, that differ by more than this tabulated r (for any given level) must be considered as derived from different or nonidentical sample populations.

12.7 *Reproducibility*— The reproducibility, R , of this test method has been established as the appropriate value tabulated in Table 1. Two single test results obtained in two different laboratories, under normal test method procedures, that differ by more than the tabulated R (for any given value) must be considered to have come from different or nonidentical sample populations.

12.8 Repeatability and reproducibility expressed as percent of the mean level, (r) and (R), have equivalent application statements as above for r and R . For (r) and (R) statements, the difference in the two single test results is expressed as a percent of the arithmetic mean of the two test results.

⁸ Supporting data are available from [have been filed at ASTM International Headquarters](#) and may be obtained by requesting Research Report RR: D11-1082.

TABLE 1 Type 1 Precision

NOTE 1— Sr = repeatability standard deviation in measurement units; r = repeatability = $2.83 \times Sr$ (in measurement units); (r) = repeatability in percent of the mean; SR = reproducibility standard deviation in measurement units; R = reproducibility = $2.83 \times SR$ (in measurement units); and (R) = reproducibility in percent of the mean.

Test Value	Rubber	ML1 + 4 (100°C)	Compression Force (N)	Mean Value	Within Laboratory			Between Laboratory		
					Sr	r	(r)	SR	R	(R)
dt_1 (s)	BR	47	47	11.4	0.26	0.74	6.5	0.32	0.91	7.9
	OE-BR	38	43	11.7	0.37	1.05	8.9	0.53	1.50	12.8
	NBR 1	33	14	12.6	0.20	0.57	4.5	0.51	1.44	11.5
	NBR 2	83	79	11.5	0.32	0.91	7.9	0.45	1.27	11.1
	CR 1	46	35	12.1	0.31	0.88	7.3	0.33	0.93	7.7
	CR 2	104	92	12.7	0.36	1.02	8.0	0.57	1.61	12.7
DE (0.1 mm)	BR	47	47	44.5	0.49	1.39	3.1	0.82	2.32	5.2
	OE-BR	38	43	41.4	0.64	1.81	4.4	1.04	2.94	7.1
	NBR 1	33	14	16.9	0.31	0.88	5.2	0.50	1.42	8.4
	NBR 2	83	79	39.4	0.73	2.07	5.2	1.28	3.62	9.2
	CR 1	46	35	31.0	0.52	1.47	4.7	1.00	2.83	9.1
	CR 2	104	92	42.5	0.84	2.38	5.6	1.37	3.88	9.1
q	BR	47	47	0.325	0.0029	0.0082	2.5	0.0050	0.0142	4.4
	OE-BR	38	43	0.339	0.0046	0.0130	3.8	0.0076	0.0215	6.3
	NBR 1	33	14	0.257	0.0019	0.0054	2.1	0.0026	0.0074	2.9
	NBR 2	83	79	0.302	0.0025	0.0071	2.3	0.0029	0.0082	2.7
	CR 1	46	35	0.296	0.0029	0.0082	2.8	0.0043	0.0122	4.1
	CR 2	104	92	0.296	0.0033	0.0093	3.2	0.0038	0.0108	3.6
Δdt_{21} (%)	BR	47	47	-31.2	1.07	3.03	9.7	3.37	9.54	30.6
	OE-BR	38	43	-26.4	1.62	4.58	17.4	2.82	7.98	30.2
	NBR 1	33	14	-25.6	0.99	2.80	10.9	1.79	5.07	19.8
	NBR 2	83	79	-23.5	1.05	2.97	12.6	2.56	7.24	30.8
	CR 1	46	35	-22.9	1.20	3.40	14.8	2.66	7.53	32.9
	CR 2	104	92	-24.1	0.94	2.66	11.0	2.29	6.48	26.9

12.9 In test method terminology, bias is the difference between an average test value and the reference (or true) test property value. Reference values do not exist for this test method since the values of viscosity and elasticity are exclusively defined by this test method. Bias, therefore, cannot be determined.

13. Keywords

13.1 compression and recovery; compression force test; elastic behavior; elastic properties; elastic recovery; elasticity; material fatigue; non-Newtonian viscosity; parallel plate; viscosity; viscous behavior

ANNEX

(Mandatory Information)

A1. TEST PIECE PREPARATION BY VACUUM COMPACTION IN ACCORDANCE WITH DIN 53523, PART 1

A1.1 Scope

A1.1.1 This annex describes the equipment and process for molding blister-free test pieces as outlined in DIN 53523, Part 1.

A1.2 Apparatus

A1.2.1 *Cutting tool*, with a rotating circular blade with a circumferential speed of about 150 to 250 m/min (492 to 820 ft/min) and a cutting gage adjustable to 0.8 to 2.0 mm (0.03 to 0.08 in.).

A1.2.2 *Vacuum pump*, capable of drawing 1 Pa (7.5 mm Hg) vacuum with a capacity of 4 to 10 m³/h (141 to 353 ft³/h).

A1.2.3 *Two platen press*, heatable to 105 ± 3°C (221 ± 5°F) with a minimum clamping force of 100 kN (11.2 ton).

A1.2.4 *Molds*, to prepare double test pieces as shown in Fig. A1.1, comprised of two 50 mm (2 in.) high steel cylinders (1)⁹

⁹ The boldface numbers in parentheses refer to a list of references at the end of this test method.

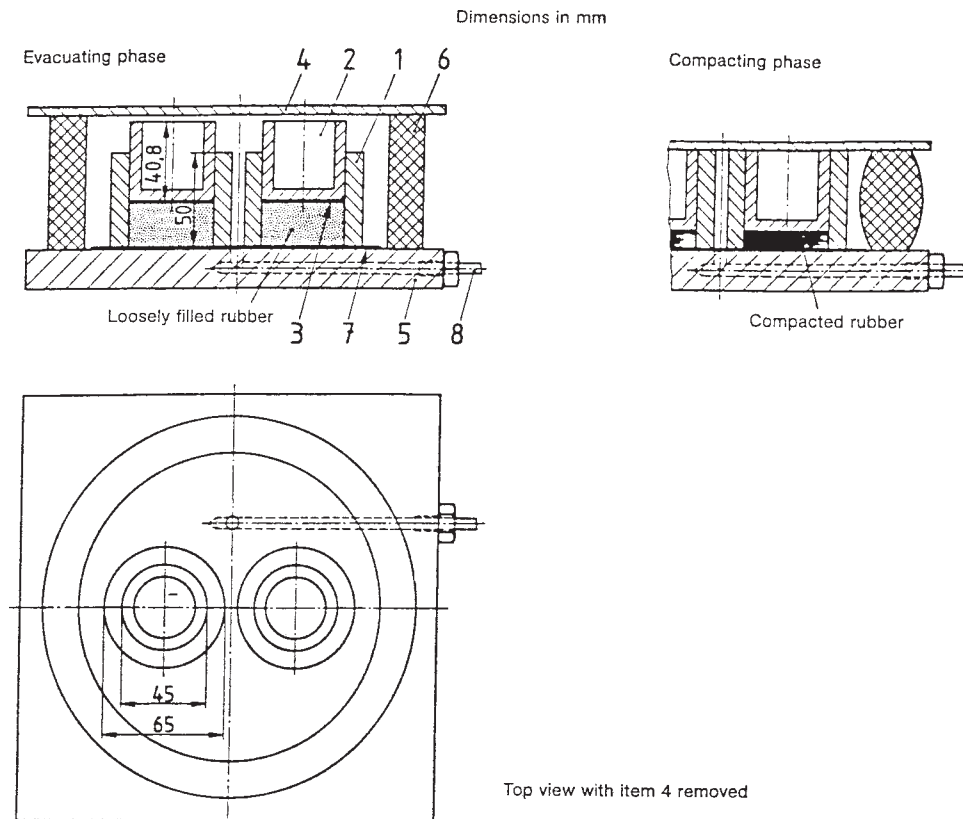

NOTE 1—*Mold*: cylinder (1), hollow piston (2), silicone rubber cover disk (3). *Vacuum Container*: cover plate (4), base plate with vacuum gate (5), silicone rubber seal ring (6), PTFE release sheet (7), vacuum connection (8).

FIG. A1.1 Vacuum Compaction Apparatus

and two hollow steel pistons (2) with a diameter of 45 mm (1.77 in.), a height of 40.8 mm (1.61 in.) and a clearance of 0.05 mm (0.002 in.). A silicone rubber cover disk (3) with a diameter of 44.6 mm (1.76 in.) and a gage of 1 mm (0.04 in.) is provided for each piston. The working volume of each cylinder is 12.5 cm³ (0.76 in.³).

A1.2.5 If the press has no build-in vacuum capability, a simple vacuum vessel shall be set up consisting of a cover plate (4), a base plate (5), a silicone rubber seal ring (6), and a polytetrafluoroethylene (PTFE) release sheet (7) as shown in Fig. A1.1.

A1.3 Vacuum Compaction Process

A1.3.1 The complete set-up is assembled in the press and preheated at 105 ± 3°C (221 ± 5°F) for 10 min (Note A1.1).

NOTE A1.1—In addition, for CR the test rubber is preheated in the vacuum equipment or separately in a hot air oven for 6 min at 105 ± 3°C (221 ± 5°F).

A1.3.2 The set-up is taken out of the press after the preheat period, the cover plate removed, and the PTFE release sheet placed on the base plate, leaving the vacuum gate uncovered.

A1.3.3 The two cylinders are positioned on the PTFE sheet as shown in Fig. A1.1, and the raw test pieces, prepared in accordance with Section 8, are placed inside the cylinders. The silicone cover disks and pistons (open side up) are then loosely inserted.

A1.3.4 The vacuum container is closed with the cover plate, placed in the press, and connected to the vacuum. A maximum residual pressure of 1 Pa (7.5 mm Hg) shall be maintained for 0.5 min. In this step the cover plate shall not touch the pistons.

A1.3.5 The platens of the press are then closed to reach a pressure of about 25 MPa (3625 psi) in the rubber mass. Pressure and vacuum are maintained for the time periods stated in 8.2.5 (10 to 15 min molding time followed by 10 min compaction time) and the press is then opened to remove the finished test pieces.

A1.4 Test pieces shall be conditioned for at least 30 min but no more than 24 h at 18 to 28°C (64 to 82°F) prior to testing.

APPENDIX

(Nonmandatory Information)

X1. BACKGROUND INFORMATION

X1.1 The test method described herein is based on the former Standard DIN 53514, Determination of Plasticity According to Baader in a Compression Test at Elevated Temperatures (Defo Test), which was withdrawn in 1972. The test method was further developed and reintroduced, resulting in simplified and faster procedures, improved precision, and more comprehensive information on the rheological behavior of the materials tested (1, 2). This test method has been proven as robust and relevant in many years of use (3–6). It is applicable to all unvulcanized rubbers, but for very hard and rigid substances the use of smaller test pieces may be considered (7).

X1.2 Viscosity related parameters are determined at relatively low shear rates, since the maximum shear rate in the medium compression time range is approximately 0.07s⁻¹, compared to about 2s⁻¹ for the Mooney viscosity test. This is the reason for the high sensitivity of this test method and its capability to detect even small differences in rheological behavior. In the interlaboratory test program described in Section 12, it was found that the average sensitivity for the compression time dt_1 of six rubbers was approximately three times higher than that for the Mooney viscosity test. Sensitivity is defined by the quotient of the material standard deviation of different lots and the repeatability standard deviation of the test method.

X1.3 In comparison to many other rheological test methods, this method is free of interferences from slip/stick phenomena. It is also simpler, faster, and more sensitive, and provides more comprehensive information than similar parallel plate plastometer tests, for example, Test Method D 926 or ISO 7323. In addition, a broader range of materials can be tested and evaluated.

REFERENCES

- (1) Koopmann, R., Kautsch. Gummi, Kunstst., Vol 36, No. 2, 1983, pp. 108–119.
- (2) Koopmann, R., Schnetger, J., Kautsch. Gummi, Kunstst., Vol 39, No. 2, 1986, pp. 131–140.
- (3) Koopmann, R., Marwede, G., Kautsch. Gummi, Kunstst., Vol 45, No. 2, 1992, pp. 133–140.
- (4) Schramm, G., Kautsch. Gummi, Kunstst., Vol 40, No. 8, 1987, pp. 756–765.
- (5) Schramm, G., Kontrolle, 1987, June pp. 80–81; July pp. 38–42.
- (6) Schramm, G., Kautsch. Gummi, Kunstst., Vol 43, No. 9, 1990, pp. 726–738.
- (7) Schramm, G., Kautsch. Gummi, Kunstst., Vol 43, No. 12, 1990, pp. 1074–1082.

ASTM International takes no position respecting the validity of any patent rights asserted in connection with any item mentioned in this standard. Users of this standard are expressly advised that determination of the validity of any such patent rights, and the risk of infringement of such rights, are entirely their own responsibility.

This standard is subject to revision at any time by the responsible technical committee and must be reviewed every five years and if not revised, either reapproved or withdrawn. Your comments are invited either for revision of this standard or for additional standards and should be addressed to ASTM International Headquarters. Your comments will receive careful consideration at a meeting of the responsible technical committee, which you may attend. If you feel that your comments have not received a fair hearing you should make your views known to the ASTM Committee on Standards, at the address shown below.

This standard is copyrighted by ASTM International, 100 Barr Harbor Drive, PO Box C700, West Conshohocken, PA 19428-2959, United States. Individual reprints (single or multiple copies) of this standard may be obtained by contacting ASTM at the above address or at 610-832-9585 (phone), 610-832-9555 (fax), or service@astm.org (e-mail); or through the ASTM website (www.astm.org).