



Standard Test Methods for Rigid Tubes Used for Electrical Insulation¹

This standard is issued under the fixed designation D 348; the number immediately following the designation indicates the year of original adoption or, in the case of revision, the year of last revision. A number in parentheses indicates the year of last reapproval. A superscript epsilon (ϵ) indicates an editorial change since the last revision or reapproval.

This standard has been approved for use by agencies of the Department of Defense.

1. Scope

1.1 These test methods cover the testing of rigid tubes used in electrical insulation. These tubes include many types made from fibrous sheets of basic materials, such as cellulose, asbestos, glass, or nylon, in the form of paper, woven fabrics, or mats, bonded together by natural or synthetic resins or by adhesives. Such tubes include vulcanized fiber and thermosetting laminates, as well as tubes made from cast, molded, or extruded natural or synthetic resins, with or without fillers or reinforcing materials.

1.2 Tubes tested by these test methods are most commonly circular in cross-section; however, non-circular shapes are also in commercial use. To the extent that the individual methods are compatible with a particular non-circular shape, these test methods are applicable to these other shapes. For tests on non-circular tubes, appropriate comments should be included in the test report, including details of orientation of test specimens with respect to the cross-section of the tube.

1.3 The procedures appear in the following sections:

Procedure	Sections	ASTM Method Reference
Compressive Strength (Axial and Diametral)	11 to 16	E 4
Compressive Strength (Axial and Diametral)	12 to 17	E 4
Conditioning	3	...
Conditioning	4	...
Density	19 to 23	...
Density	20 to 24	...
Dielectric Strength	24 to 31	D 149
Dielectric Strength	25 to 32	D 149
Dimensional Measurements	4	D 668
Dimensional Measurements	5	D 668
Dissipation Factor and Permittivity	32 to 34	D 150
Dissipation Factor and Permittivity	33 to 35	D 150
Tensile Strength	5 to 10	E 4
Tensile Strength	6 to 11	E 4
Water Absorption	17 to 18	D 570
Water Absorption	18 to 19	D 570

1.4 The values stated in inch-pound units are to be regarded as the standard. SI units in parentheses are for information only.

1.5 *This standard does not purport to address all of the safety concerns, if any, associated with its use. It is the responsibility of the user of this standard to establish appropriate safety and health practices and determine the applicability of regulatory limitations prior to use.* For a specific hazard statement, see 267.1.1.

2. Referenced Documents

2.1 *ASTM Standards:*

¹ These test methods are under the jurisdiction of ASTM Committee D-9, D09 on Electrical and Electronic Insulating Materials and are the direct responsibility of Subcommittee D09.07 on Flexible and Rigid Insulating Materials.

Current edition approved Jan. 15, 1995; Apr. 10, 2000. Published March 1995; June 2000. Originally published as D 348 – 32T. Last previous edition D 348 – 905.

- D 149 Test Methods for Dielectric Breakdown Voltage and Dielectric Strength of Solid Electrical Insulating Materials at Commercial Power Frequencies²
- D 150 Test Methods for A-C Loss Characteristics and Permittivity (Dielectric Constant) of Solid Electrical Insulating Materials²
- D 570 Test Method for Water Absorption of Plastics³
- D 668 Test Methods for Measuring Dimensions of Rigid Rods and Tubes Used for Electrical Insulation²
- D 1711 Terminology Relating to Electrical Insulation²
- E 4 Practices for Load Force Verification of Testing Machines⁴

3. Terminology

3.1 *Definitions*— For definitions of terms used in these test methods, refer to Terminology D 1711.

4. Conditioning

34.1 In order to eliminate the effects of previous history of humidity exposure and to obtain reproducible results (Note 1), the test specimens in all cases of dispute, shall be given a conditioning treatment for physical tests (Note 2) as follows:

34.1.1 *Tensile Strength, Compressive Strength (Axial and Diametral), and Density*—Condition the machined specimens prior to test by drying in an air-circulating oven for 48 h at $50 \pm 3^\circ\text{C}$, followed by cooling to room temperature in a desiccator. In either case, all specimens shall be tested at room temperature maintained at $23 \pm 2^\circ\text{C}$, 50 % relative humidity.

NOTE 1—Conditioning of specimens may be undertaken: (a) for the purpose of bringing the material into equilibrium with standard laboratory atmospheric conditions of 23°C and 50 % relative humidity; (b) simply to obtain reproducible results, irrespective of previous history of exposure; or (c) to subject the material to abnormal conditions of temperature or humidity in order to predict its service behavior.

The conditions given here to obtain reproducible results may give physical values somewhat higher or somewhat lower than values under equilibrium at normal conditions, depending upon the particular material and test. To ensure substantial equilibrium under normal conditions of humidity and temperature, however, will require from 20 to 100 days or more depending upon thickness and type of material and its previous history. Consequently, conditioning for reproducibility must of necessity be used for general purchase specifications and product control tests.

NOTE 2—Conditioning of specimens for electrical tests is also necessary to obtain consistent results. In order to secure comparative results, specimens should be conditioned at the same temperature and humidity.

45. Dimensional Measurements

45.1 Dimensional measurements of tube shall be made in accordance with Test Methods D 668.

TENSILE STRENGTH

5. Significance and Use

5.1 Tension tests, properly interpreted, provide information with regard to the tensile properties of rigid tubing, when employed under conditions approximating those under which the tests are made. The tensile strength values may vary with the size of the tube and with the temperature and atmospheric conditions. Tension tests may provide data for research and development and for engineering design, and are useful for quality control purposes.

6. Apparatus

6.1 Any universal testing machine may be used provided it is accurate.

6.1 Tension tests, properly interpreted, provide information with regard to 1 % of the lowest breaking load to be applied. Jaws that tighten tensile properties of rigid tubing, when employed under load, such as wedge-grip jaws, shall be used conditions approximating those under which the tests are made. The tensile strength values may vary with the specimen properly aligned.

6.2 The machine shall be verified in accordance size of the tube and with Practices E 4. the temperature and atmospheric conditions. Tension tests may provide data for research and development and for engineering design, and are useful for quality control purposes.

7. Apparatus

7.1 Any universal testing machine may be used provided it is accurate to 1 % of the lowest breaking load to be applied. Jaws that tighten under load, such as wedge-grip jaws, shall be used with the specimen properly aligned.

7.2 The machine shall be verified in accordance with Practices E 4.

8. Test Specimens

78.1 The test specimens shall be as shown in Fig. 1. The length, L , shall be as shown in Table 1. A groove shall be machined around the outside of the specimen at the center of its length so that the wall section after machining shall be 60 % of the original

² Annual Book of ASTM Standards, Vol 10.01.

³ Annual Book of ASTM Standards, Vol 08.01.

⁴ Annual Book of ASTM Standards, Vol 03.01.

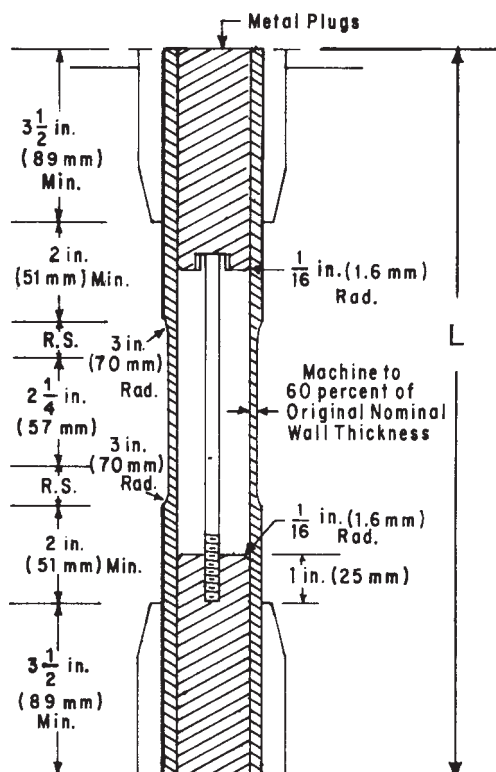

FIG. 1 Diagram Showing Location of Tube Tension Test Specimen in Testing Machine

TABLE 1 Dimensions of Tension Specimens, in. (mm)

Nominal Wall Thickness	Length of Radial Sections, 2R.S.	Total Calculated Minimum Length of Specimen	Standard Length, L, of Specimen to be Used for 3 1/2-in. (89-mm) Jaws ^A
1/32 (0.79)	0.547 (13.9)	13.80 (350.0)	15 (381.0)
3/64 (1.2)	0.670 (17.0)	13.92 (354.0)	15 (381.0)
1/16 (1.6)	0.773 (19.6)	14.02 (356.0)	15 (381.0)
3/32 (2.4)	0.946 (24.0)	14.20 (361.0)	15 (381.0)
1/8 (3.2)	1.091 (27.7)	14.34 (364.0)	15 (381.0)
3/16 (4.8)	1.333 (33.9)	14.58 (370.0)	15 (381.0)
1/4 (6.4)	1.536 (39.0)	14.79 (376.0)	15.75 (400.0)
5/16 (7.9)	1.714 (43.5)	14.96 (380.0)	15.75 (400.0)
3/8 (9.5)	1.873 (47.6)	15.12 (384.0)	15.75 (400.0)
7/16 (11.1)	2.019 (51.3)	15.27 (388.0)	15.75 (400.0)
1/2 (12.7)	2.154 (54.7)	15.40 (391.0)	16.5 (419.0)

^A For other jaws greater than 3 1/2 in. (89 mm), the standard length shall be increased by twice the length of the jaws minus 7 in. (178 mm). The standard length permits a slippage of approximately 1/4 to 1/2 in. (6.4 to 12.7 mm) in each jaw while maintaining maximum length of jaw grip.

nominal wall thickness. This groove shall consist of a straight section 2.25 in. (57 mm) in length with a radius of 3 in. (76 mm) at each end joining it to the outside diameter. Steel or brass plugs having diameters such that they will fit snugly inside the tube, and having a length equal to the full jaw length plus 1 in. (25 mm) shall be placed in the ends of the specimen to prevent crushing. They can be located in the tube conveniently by separating and supporting them on a threaded metal rod. Details of plugs and test assembly are shown in Fig. 1.

89. Procedure

89.1 Test five specimens. Measure the average inside and outside diameters, determined from at least two measurements 90° apart, at the groove to the nearest 0.001 in. (0.03 mm) and calculate the cross-sectional area from these dimensions. Assemble the metal plugs with the tube as shown in Fig. 1. Grasp this assembly in the V-notched jaws of the testing machine.

89.2 Speed of Testing—The crosshead speed of the testing machine shall be such that the load can be accurately weighed, but shall not exceed 0.05 in./min (1.3 mm/min) when the machine is running idle.

910. Report

910.1 Report the following information:

910.1.1 The average inside and outside diameters of the specimen expressed to the nearest 0.001 in. (0.03 mm), each determined from at least two measurements 90° apart,

- 910.1.2 The average outside diameter of the reduced section expressed to the nearest 0.001 in. (0.03 mm),
- 910.1.3 The full wall thickness of the specimen,
- 910.1.4 The net area of the test section, in.² or mm²,
- 910.1.5 The breaking load of each specimen, lbf or N,
- 910.1.6 The tensile strength of each specimen, psi or MPa, and
- 910.1.7 The room temperature.

101. Precision and Bias

101.1 *Precision*—This test method has been in use for many years, but no information has been presented to ASTM upon which to base a statement of precision. No activity has been made and no activity is planned to develop such a statement. Since there is information.

11.2 *Bias*—This test method has no accepted reference material, no statement on bias because the value for tensile strength is being made. determined solely in terms of this test method.

COMPRESSIVE STRENGTH (AXIAL AND DIAMETRAL)

11. Significance and Use

11.1 Compressive tests, properly interpreted, provide information with regard to the compressive properties of rigid tubing when employed under conditions approximating those under which the tests are made. The compressive strength values may vary with the size of the tube, and with temperature and atmospheric conditions. Compression tests may provide data for research and development, engineering design, quality control, and acceptance or rejection under specifications.

12. Significance and Use

12.1 Compressive tests, properly interpreted, provide information with regard to the compressive properties of rigid tubing when employed under conditions approximating those under which the tests are made. The compressive strength values may vary with the size of the tube, and with temperature and atmospheric conditions. Compression tests may provide data for research and development, engineering design, quality control, and acceptance or rejection under specifications.

13. Apparatus

123.1 Any universal testing machine may be used provided it is accurate to 1 % of the lowest breaking load to be applied, in accordance with Practices E 4. One end of the specimen for axial loading or the side of the specimen for diametral loading shall bear upon an accurately centered spherical bearing block, located whenever practicable at the top. The metal bearing plates shall be directly in contact with the test specimen.

NOTE 3—Off-center loading of the diametral compressive test may cause the tube to push to one side.

134. Test Specimens

134.1 Unless otherwise specified, the material shall be tested in the as-received condition.

134.2 Test specimens shall consist of 1-in. (25-mm) long sections of the tubing.

134.3 Care shall be taken in cutting the test specimens for the axial tests, to have the ends of the specimens cut accurately and smoothly at right angles to the axis of the tube.

NOTE 4—If the tubing is too large in diameter, or is too high in breaking strength to be tested with the available testing equipment, a segment of the test specimen specified in 134.2 and 134.3 may be substituted for axial tests. Such segments should not be used for testing tubes less than 2 in. (51 mm) in outside diameter. Unless otherwise specified, use segments having a circumferential length of 2 in. (51 mm).

145. Procedure

145.1 Test five specimens axially, with the load applied perpendicular to the faces or ends of the specimen, or test five specimens diametrically, with the load applied perpendicular to the tangent at point of application.

145.2 Discard specimens that break at some obvious fortuitous flaw and retest, unless such flaws constitute a variable, the effect of which it is desired to study.

145.3 Retain results (on specimens) that deviate markedly from the mean value of all tests unless 145.2 applies. In this case run additional tests, the exact number to be fixed by the desired (statistical) significance level.

145.4 *Speed of Testing*—The crosshead speed of the testing machine shall be 0.050 in./min (1.3 mm/min) when the machine is running idle. In cases of diametral loading of certain tubing, especially the larger diameter tubes, it may be necessary to operate the crosshead at a speed of loading greater than 0.050 in./min. In this event the speed should be stated in the report.

15. Report

15.1 Report the following information:

15.1.1 The average inside and outside diameters of the specimen expressed to the nearest 0.001 in. (0.03 mm), each determined from at least two measurements 90° apart,

- ~~15.1.2 The average wall thickness of the specimen expressed to the nearest 0.001 in. (0.03 mm);~~
- ~~15.1.3 The segment length, if segmental specimens are used for axial tests;~~
- ~~15.1.4 The direction of application of the load;~~
- ~~15.1.5 The load on each specimen at the first sign of rupture, lbf or N, and~~
- ~~15.1.6 The ultimate compressive strength in force per unit area for axial loading and force for diametral loading.~~

16. Report

~~16.1 Report the following information:~~

~~16.1.1 The average inside and outside diameters of the specimen expressed to the nearest 0.001 in. (0.03 mm), each determined from at least two measurements 90° apart,~~

~~16.1.2 The average wall thickness of the specimen expressed to the nearest 0.001 in. (0.03 mm),~~

~~16.1.3 The segment length, if segmental specimens are used for axial tests,~~

~~16.1.4 The direction of application of the load,~~

~~16.1.5 The load on each specimen at the first sign of rupture, lbf or N, and~~

~~16.1.6 The ultimate compressive strength in force per unit area for axial loading and force for diametral loading.~~

17. Precision and Bias

~~16.1 This test method has been in use~~

~~17.1 Precision—Same as 11.1.~~

~~17.2 Bias—Same as 11.2 except for many years, but no statement the property of precision has been made and no activity is planned to develop such a statement. Since there is no accepted reference material, no statement on bias is being made. compressive strength.~~

WATER ABSORPTION

17. Significance and Use

~~17.1 The moisture content of a rigid tube has a definite influence on the electrical properties, as well as on mechanical strength, dimensional stability, and appearance. The effect upon these properties of changes in moisture content, due to water absorption, depends largely upon the inherent properties of the rigid tube. The rate of water absorption may be widely different through each edge and surface. A water absorption determination will provide data useful for research and development, engineering design, quality control, and acceptance or rejection under specifications.~~

18. Significance and Use

~~18.1 The moisture content of a rigid tube has a definite influence on the electrical properties, as well as on mechanical strength, dimensional stability, and appearance. The effect upon these properties of changes in moisture content, due to water absorption, depends largely upon the inherent properties of the rigid tube. The rate of water absorption may be widely different through each edge and surface. A water absorption determination will provide data useful for research and development, engineering design, quality control, and acceptance or rejection under specifications.~~

19. Procedure

~~189.1 Determine and report the rate of water absorption in accordance with Test Method D 570, immersing specimens for 24 h in distilled water at 23°C after preliminary conditioning for 1 h at 105°C.~~

~~189.2 For some types of materials, or for special applications, it may be desirable to employ longer periods of water immersion in order to evaluate performance. In these cases, the report shall indicate the exact conditioning procedure.~~

DENSITY

19. Significance and Use

~~19.1 A density measurement will provide data useful for research and development, engineering design, quality control, and acceptance or rejection under specifications.~~

20. Test Specimens

~~20.1 Any suitable size specimen may be used. The specimen 1 in. (25 mm) in length used for the water absorption test (Sections 17 Significance and 18) Use~~

~~20.1 A density measurement will provide data useful for research and development, engineering design, quality control, and acceptance or rejection under specifications.~~

21. Test Specimens

~~21.1 Any suitable size specimen may be used. The specimen 1 in. (25 mm) in length used for the water absorption test (Sections 18 and 19) will be found convenient.~~

22. Procedure

242.1 Test two specimens using any suitable hydrostatic displacement apparatus capable of weighing to the nearest 0.1 % relative, using an immersion liquid (water) at a temperature of $23 \pm 2^\circ\text{C}$. Results of these tests shall be considered valid if they agree within 0.5 % relative.

242.2 Compute the average density in g/cm^3 .

NOTE 5—Materials susceptible to moisture absorption may be evaluated by weighing specimens in air and computing the density from volume data obtained by dimensional measurements. This value is properly termed “apparent density.”

223. Report

223.1 Report the density (apparent density) in g/cm^3 , and state the temperature at which the determination was made if different from 23°C .

234. Precision and Bias

~~23.1 This test method has been in use~~

~~24.1 Precision—Same as 11.1.~~

~~24.2 Bias—Same as 11.2 except for many years, but no statement the property of precision has been made and no activity is planned to develop such a statement. Since there is no accepted reference material, no statement on bias is being made. density.~~

DIELECTRIC STRENGTH

24. Significance and Use

~~24.1 The dielectric strength of a rigid tube will depend upon a number of factors, such as: wall thickness; direction of applied dielectric stress, whether transverse or parallel to the axis; rate of application of voltage; and frequency, temperature, and surrounding atmospheric humidity. The test values for dielectric strength determined by standard procedure will not correspond to those obtained in service unless the conditions of test are the same. The test values for dielectric strength usually give only some indication of insulation quality under service conditions. Dielectric strength tests may provide data for research and development, engineering design, quality control, and acceptance or rejection under specifications.~~

25. Significance and Use

25.1 The dielectric strength of a rigid tube will depend upon a number of factors, such as: wall thickness; direction of applied dielectric stress, whether transverse or parallel to the axis; rate of application of voltage; and frequency, temperature, and surrounding atmospheric humidity. The test values for dielectric strength determined by standard procedure will not correspond to those obtained in service unless the conditions of test are the same. The test values for dielectric strength usually give only some indication of insulation quality under service conditions. Dielectric strength tests may provide data for research and development, engineering design, quality control, and acceptance or rejection under specifications.

26. Conditioning

256.1 Unless otherwise specified, all test specimens shall be conditioned for 48 h at $50 \pm 3^\circ\text{C}$ in a circulating air oven prior to testing. After removal from the oven, specimens shall be permitted to cool to room temperature in a desiccator over anhydrous CaCl_2 .

256.2 In the case of tubes to be used at other than room temperature, the dielectric strength characteristics shall be determined over the operating range of temperature. Prior to test, specimens previously conditioned as described in 256.1 shall be exposed to each test temperature in a suitable temperature-control chamber for a period of minutes equal to one half the wall thickness of the specimen in mils.

267. Procedure

267.1 Determine the dielectric strength in accordance with Test Method D 149, except as specified herein.

267.1.1 **Caution:** *Lethal voltages are a potential hazard during the performance of this test. It is essential that the test apparatus, and all associated equipment electrically connected to it, be properly designed and installed for safe operation. Solidly ground all electrically conductive parts which it is possible for a person to contact during the test. Provide means for use at the completion of any test to ground any parts which were at high voltage during the test or have the potential for acquiring an induced charge during the test or retaining a charge even after disconnection of the voltage source. Thoroughly instruct all operators as to the correct procedures for performing tests safely. When making high voltage tests, particularly in compressed gas or in oil, it is possible for the energy released at breakdown to be sufficient to result in fire, explosion, or rupture of the test chamber. Design test equipment, test chambers, and test specimens so as to minimize the possibility of such occurrences and to eliminate the possibility of personal injury. If the potential for fire exists, have fire suppression equipment available.*

267.2 Test transverse or parallel with the wall of the tube, or both, depending upon whether the stress on the tube, when in use, is to be transverse or parallel with the wall, or both.

278. Electrodes and Test Specimens

278.1 *For Testing in Transverse Direction*—The inner electrode shall consist of a brass rod, 3 in. (76 mm) in length, with edges rounded to a ¼-in. (6.4-mm) radius and of such diameter that it fits snugly inside the tube to be tested. The outer electrode shall consist of a strip of metal foil 2½ in. (64 mm) in width and long enough to extend around the circumference of the tube. The test specimen should be of sufficient length to prevent flashover.

278.2 *For Testing Parallel with Laminations*—The test specimens shall be ½ in. (12.7 mm) in length. A hole shall be drilled into one end of the test specimen in the approximate center of the wall parallel with the major axis of the tube to a depth of ⅞ in. (11.1 mm), leaving a thickness of ⅛ in. (1.6 mm) to be tested. A snug-fitting metal-pin electrode, with the end ground to conform with the shape of the drill used, shall be inserted in the hole. The specimen shall be placed on a flat metal plate having a diameter at least ½ in. (13 mm) greater than that of the specimen. This plate shall serve as the lower electrode. Thus, in effect, the material shall be tested parallel with lamination in a point-plane gap. The diameter of the hole shall be as shown in the following table:

Nominal Wall Thickness of Tubes, in. (mm)	Nominal Hole Diameter for Pin Electrode, in. (mm)
⅛ to ¼ (3.2 to 6.4), incl	⅛ (1.6)
Over ¼ (6.4)	⅜ (3.2)

NOTE 6—For tubes with exceptionally high dielectric strength, surface flashover may occur. Such cases shall be noted in the report.

289. Surrounding Medium

289.1 The specimens shall be tested immersed in a suitable liquid medium maintained at the test temperature specified.

NOTE 7—The nature of the dielectric immersion liquid may appreciably affect the electric breakdown.

29.—

30. Procedure

2930.1 Make test by either the short-time test method or the step-by-step test method.

2930.2 In tests made by the short-time test method, increase the voltage at the rate of 0.5 kV/s. In tests made by the step-by-step test method, apply the voltage at each step for 1 min. Increase the voltage in increments as follows:

Breakdown Voltage by Short-Time Test Method, kV	Increment of Increase of Test Voltage, kV
25 or less	1.0
Over 25 to 50, incl	2.0
Over 50 to 100, incl	5.0
Over 100	10.0

2930.3 At least five tests shall be made at each temperature in the short-time test method, and at least three tests in the step-by-step test method. When the range of test temperatures is considerable, tests should be made at not less than five temperatures, if a curve of dielectric strength against temperature is desired.

301. Report

301.1 Report the following information:

301.1.1 A description of the material including name, type, grade, color, size, and name of the manufacturer,

301.1.2 A statement of the direction of dielectric stress application, whether transverse to or parallel with laminations,

301.1.3 The conditioning treatment which the specimens have received,

301.1.4 A statement of the procedure used, whether short-time test method or step-by-step test method,

301.1.5 Nominal wall thickness of the tube in inches or millimetres,

301.1.6 The maximum, minimum, and average puncture voltage in kilovolts and volts per mil or per millimetre (Note 8),

301.1.7 Duration of the test, if the step-by-step test method has been used, including the initially applied voltage in kilovolts,

301.1.8 The temperature of the test specimen,

301.1.9 The size and type of electrodes, and

301.1.10 For transverse breakdowns, the location of the breakdowns, whether under the outer electrode, at the edge of the outer electrode or beyond the edge.

NOTE 8—To calculate the volts per mil, the wall thickness in transverse tests on material undisturbed by breakdown but as near the point of breakdown as possible shall be used. For tests parallel with laminations, the thickness of the section shall be measured prior to breakdown. This can be done conveniently by measuring the length of the electrode, then the combined length of the specimen and electrode with the electrode inserted in place.

312. Precision and Bias

31.1 This test method has been in use

32.1 *Precision*—Same as 11.1.

~~32.2 *Bias*—Same as 11.2 except for many years, but no statement the property of precision has been made and no activity is planned to develop such a statement. Since there is no accepted reference material, no statement on bias is being made. dielectric strength.~~

DISSIPATION FACTOR AND PERMITTIVITY

323. Significance and Use

323.1 The dissipation factor is a measure of the a-c energy loss in the material. The measured dissipation factor can vary over a wide range depending upon the composition of the material. Dissipation factor is affected by frequency, voltage gradient, temperature of measurement, and previous conditioning.

323.2 The permittivity will vary over only a limited range for a given material, but is affected also by frequency, temperature, and previous conditioning.

323.3 For quality-control and specification purposes, the dissipation factor may, in some cases, be of more significance than the permittivity, and is frequently the only one of the two values which is specified. For design and research purposes, both properties are usually of significance.

323.4 Refer to Test Methods D 150 for further information on the significance of this test method.

334. Electrodes

334.1 For referee purposes, the three-terminal cylindrical guarded electrode system as illustrated in Table 1 of Test Methods D 150 shall be used following the guidelines for selection of electrode materials and method of application as given in Test Methods D 150.

334.2 For routine quality control purposes, cylindrical electrodes without guard rings, as illustrated in Table 1 of Test Methods D 150, may be used. The inner electrode may be a solid piece conforming to the inside shape of the tube. Both electrodes shall conform closely to the surface of the tube to minimize the air gap between either electrode and the tube.

NOTE 9—The accuracy of dissipation factor and permittivity measurements is affected significantly by an air gap in series with the test specimen. Gap thicknesses of 10 % of the specimen thickness, for example, may introduce errors in these measurements of up to 50 % for some materials.

334.3 For large sizes, and for some non-circular shapes, it may be more convenient to use electrodes which are similar in geometry to those used for flat plate specimens, as described in Test Methods D 150. In such cases, the electrode geometry shall be as mutually agreed to by the interested parties.

34. Precision and Bias

~~34.1 This test method has been in use for many years, but no statement of precision has been made and no activity is planned to develop such a statement. Since there is no accepted reference material, no statement on bias is being made.~~

35. Precision and Bias

35.1 *Precision*—Same as 11.1.

35.2 *Bias*—Same as 11.2 except for the property of dissipation factor and permittivity.

36. Keywords

356.1 compressive strength; density; dielectric strength; dissipation factor; permittivity; rigid tubes; tensile strength; thermosetting laminate; vulcanized fibre; water absorption

ASTM International takes no position respecting the validity of any patent rights asserted in connection with any item mentioned in this standard. Users of this standard are expressly advised that determination of the validity of any such patent rights, and the risk of infringement of such rights, are entirely their own responsibility.

This standard is subject to revision at any time by the responsible technical committee and must be reviewed every five years and if not revised, either reapproved or withdrawn. Your comments are invited either for revision of this standard or for additional standards and should be addressed to ASTM International Headquarters. Your comments will receive careful consideration at a meeting of the responsible technical committee, which you may attend. If you feel that your comments have not received a fair hearing you should make your views known to the ASTM Committee on Standards, at the address shown below.

This standard is copyrighted by ASTM International, 100 Barr Harbor Drive, PO Box C700, West Conshohocken, PA 19428-2959, United States. Individual reprints (single or multiple copies) of this standard may be obtained by contacting ASTM at the above address or at 610-832-9585 (phone), 610-832-9555 (fax), or service@astm.org (e-mail); or through the ASTM website (www.astm.org).