



Standard Test Method for Specific Resistance (Resistivity) of Electrical Insulating Liquids¹

This standard is issued under the fixed designation D 1169; the number immediately following the designation indicates the year of original adoption or, in the case of revision, the year of last revision. A number in parentheses indicates the year of last reapproval. A superscript epsilon (ϵ) indicates an editorial change since the last revision or reapproval.

1. Scope

1.1 This test method covers the determination of specific resistance (resistivity) applied to new electrical insulating liquids, as well as to liquids in service, or subsequent to service, in cables, transformers, circuit breakers, and other electrical apparatus.

1.2 This test method covers a procedure for making referee tests with dc potential.

1.3 When it is desired to make routine determinations requiring less accuracy, certain modifications to this test method are permitted as described in Sections 19-26.

1.4 *This standard does not purport to address all of the safety concerns, if any, associated with its use. It is the responsibility of the user of this standard to establish appropriate safety and health practices and determine the applicability of regulatory limitations prior to use.* See Note 5 for a specific cautionary statement.

2. Referenced Documents

2.1 ASTM Standards:

- D 150 Test Methods for A-C Loss Characteristics and Permittivity (Dielectric Constant) of Solid Electrical Insulating Materials²
- D 257 Test Methods for D-C Resistance or Conductance of Insulating Materials²
- D 923 Test Method for Sampling Electrical Insulating Liquids³
- D 924 Test Method for Dissipation Factor (or Power Factor) and Relative Permittivity (Dielectric Constant) of Electrical Insulating Liquids³
- E 145 Specification for Gravity-Convection and Forced-Ventilation Ovens⁴

3. Terminology

3.1 Definitions of Terms Specific to This Standard:

¹ This test method is under the jurisdiction of ASTM Committee D-27 on Electrical Insulating Liquids and Gases and is the direct responsibility of Subcommittee D27.05 on Electrical Tests.

Current edition approved Sept. 10, 1995. Published November 1995. Originally published as D 1169 – 51 T. Last previous edition D 1169 – 89.

² Annual Book of ASTM Standards, Vol 10.01.

³ Annual Book of ASTM Standards, Vol 10.03.

⁴ Annual Book of ASTM Standards, Vol 14.02.

3.1.1 *specific resistance (resistivity), n* —the ratio of the dc potential gradient in volts per centimetre paralleling the current flow within the specimen, to the current density in amperes per square centimetre at a given instant of time and under prescribed conditions. This is numerically equal to the resistance between opposite faces of a centimetre cube of the liquid. The units are ohm-centimetres.

4. Significance and Use

4.1 The resistivity of a liquid is a measure of its electrical insulating properties under conditions comparable to those of the test. High resistivity reflects low content of free ions and ion-forming particles, and normally indicates a low concentration of conductive contaminants.

5. General Considerations

5.1 Theory and measuring equipment pertaining to this method shall be in accordance with Test Methods D 257.

5.2 Where both ac loss characteristic (dissipation factor or power factor) and resistivity measurements are to be made consecutively on the same specimen, make the ac measurement before applying the dc potential to the specimen, and short circuit the cell electrodes for 1 min immediately prior to making the resistivity measurements.

5.3 Make referee tests for resistivity in an atmosphere of less than 50 % relative humidity. For repeatable results make these tests under carefully controlled atmospheric conditions.

5.4 Aside from the adverse influence of contamination on results of the resistivity test, there are other factors that can contribute to variations in the test results as follows:

5.4.1 The use of an instrument not having an adequate range for accurately measuring the current flowing in the circuit. (See Section 6 for two types of recommended instruments.)

5.4.2 When the time of electrification is not exactly the same for every test. Upon the application of voltage the current flow through the specimen decreases asymptotically toward a limiting value. Variation in the time of electrification can result in appreciable variation in the test results.

5.4.3 Undue length of time required for the test specimen in the cell to attain the desired test temperature. This is one of the main sources of erroneous results. For optimum results, attain the test temperature within 20 min.

5.4.4 Fluctuations in the test voltage (see 6.1.4).

6. Instrumentation

6.1 Instrumentation listed in Test Methods D 257 is suitable, with the exception of the Voltage Rate-of-Change Method. However, in order to obtain the greatest precision when making this test, use the voltage-current method with the following instruments:

6.1.1 *Voltmeter*, having an accuracy of 2 % or better, operated in the upper one third of its scale range for measuring the voltage supply.

6.1.2 *Current-Measuring Device*—Any type of instrument having adequate sensitivity and precision and with a suitable range for measurement of the wide spread of currents encountered when making this test on new or used liquids will be satisfactory. For currents greater than 10^{-9} A an Ayrton shunt and galvanometer, an appropriate electrometer or picoammeter having a sensitivity of 50 pA (50×10^{-12} A) per division has been found convenient and satisfactory. The galvanometer deflection shall be not less than 20 divisions for the applicable Ayrton shunt ratio. For currents less than 10^{-9} A an electronic picoammeter has been found suitable. In using this instrument the multiplier selected shall be such as to give at least one-half full-scale deflection on the indicating instrument.

6.1.3 *Time-Measuring Device*, accurate to 0.5 s, for measuring the time of electrification.

6.1.4 Batteries or other stable direct-voltage supplies are recommended for the steady voltage source.

NOTE 1—Rectified high-frequency power supplies cannot be used because the high frequency ripple in these supplies can cause the ac component of current to equal or exceed the dc current being measured. The ac component of current is equal to 2π times the product of the ripple voltage, the ripple frequency, and the capacitance of the test cell in farads (where $\pi = 3.14$). If the capacitance of the test cell is 100 pF (10^{-10} F), the ripple frequency is 100 kHz, and the ripple voltage is 5 mV (0.001 % of a 500 volt test voltage), the alternating component of current is 3.14×10^{-7} amperes. The meter would be unreadable under these conditions.

7. Test Circuit

7.1 A schematic diagram of the test circuit is shown in Fig. 1.

7.2 Construct the circuitry so that leakage is minimal. To this end, mount the transfer switches on polystyrene or TFE-fluorocarbon insulation of sufficient thickness to minimize possible leakage. Make all soldered connections with low-thermal-emf solder using a soldering flux of resin and alcohol.

NOTE 2—The use of ordinary solder and flux can result in spurious thermal emf's that will cause erroneous indications.

7.3 Completely shield the test circuit. Make connections to the current-measuring instrument with shielded leads. TFE-fluorocarbon-insulated shielded leads are recommended for connecting the high-voltage electrode and measuring electrode of the test cell to the test circuit.

8. Sampling

8.1 Sample oils and askarels for use in this test in accordance with Test Method D 923. When possible, obtain samples for testing through a closed system. If exposed to atmospheric conditions, take the sample when the relative humidity is 50 % or less. Some liquids, in certain applications, require special handling and processes in the sampling, and these will be found in the governing procedures. Consult such procedures before samples are taken.

8.2 Take a sufficient quantity of sample for this test for at least three separate resistivity determinations.

9. Galvanometer Calibration and Sensitivity

9.1 When a dc galvanometer is used to measure the current, it shall first be calibrated to ensure that it is properly balanced, that is, that the deflections on either side of zero are equal when the galvanometer is energized with "direct" and "reverse"

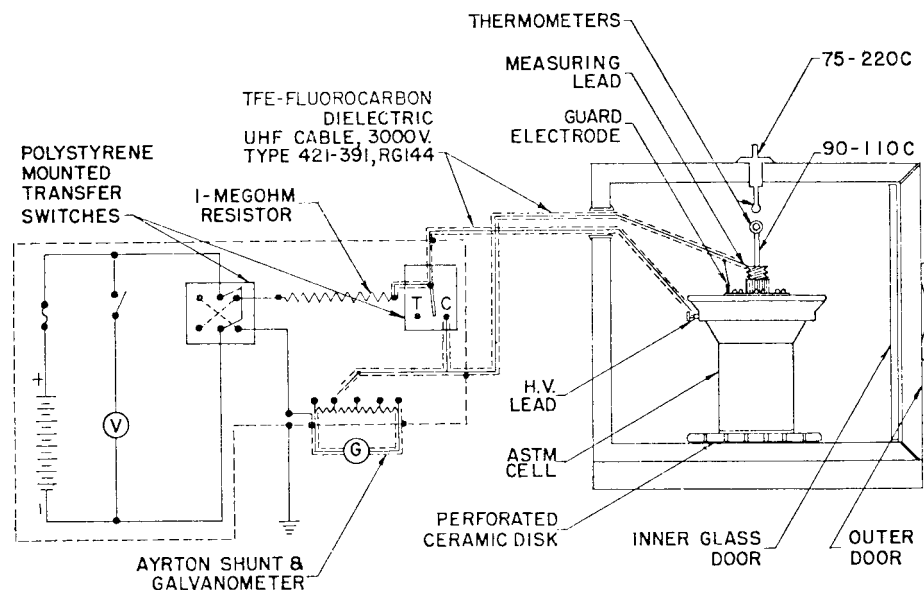

NOTE 1—For measurements of current less than 10^{-9} A replace galvanometer and shunt with picoammeter.

NOTE 2—With the S.P.D.T. switch on C terminal the galvanometer may be calibrated while the electrodes of the test cell are short-circuited.

FIG. 1 Circuit Diagram and Connections with Complete Shielding for Measuring Specific Resistance (Resistivity) of Electrical Insulating Liquids

polarities of the test potential.

NOTE 3—Throughout this test method the terms “direct polarity” and “reverse polarity” are used to indicate when the positive and negative potential leads, respectively, are connected to the outer electrode of the test cell.

9.2 The galvanometer sensitivity, G_s , in amperes per division, is used in computing the resistivity and is derived from the following equation:

$$G_s = (E/R) [m]P5 (S/D)$$

where:

- E = test voltage, V,
- R = calibrating resistor, Ω ,
- S = shunt multiplying factor (ratio of galvanometer current to total current), and
- D = galvanometer deflection, in divisions.

10. Test Cells⁵

10.1 The design of test cells that conform to the general requirements given in the Annex are considered suitable for use in making these tests.

10.2 Three types of guarded electrode test cells that conform to these requirements and have been found suitable for measuring the resistivity of insulating liquids are shown in Figs. A1.1, A1.2, and A1.3. In addition, a two-electrode cell suitable for making routine tests is shown in Fig. A1.4. These figures and a brief description of each cell are given in the Annex.

10.3 Because the configuration of the electrodes of these test cells is such that their effective area and the distance between them are difficult to measure, each test cell constant, K , can be derived from the following equation:

$$K = 3.6\pi C = 11.3C$$

where:

- K = test cell constant, cm,
- C = capacitance, pF, of the electrode system with air as the dielectric. (For methods of measuring C , see Test Methods D 150).

11. Test Chamber

11.1 When the tests are to be made above room temperature but below 300°C, use a forced-draft, thermostatically controlled oven that conforms to Specification E 145 as the test chamber. For tests at room temperature the unenergized oven can be conveniently used as the test chamber.

11.2 Provide the test chamber with an opening in the wall through which two lengths of TFE-fluorocarbon-insulated shielded cable will pass to make electrical connection from the measuring equipment and voltage source, respectively, to the test cell. Use a perforated ceramic plate or disk to insulate the test cell from the metal flooring of the oven if the flooring is not insulated from the oven.

11.3 Provide a safety interlock on the door of the test chamber so that the electrical circuit supplying voltage to the

test cell will be broken when the door is opened.

11.4 A cross-sectional view of the test chamber with a three-electrode test cell in place and with test cables connected is shown in Fig. 1.

12. Test Temperature

12.1 The temperature at which a referee test is made shall be mutually agreed upon between the purchaser and the seller. Resistivity measurements are made at many different temperatures. For acceptance tests, it is generally made at a temperature of 100°C, while for routine testing, it is usually made at room temperature, 85, or 100°C. In some research investigations, tests may be made at considerably higher temperatures, while in other cases, particularly for tests on cable oils in service, tests may be made over a range of temperatures.

13. Test Voltage

13.1 The average electrical stress to which the specimen is subjected shall be not less than 5 V/mil (200 V/mm) nor more than 30 V/mil (1200 V/mm). The upper limit has been set with the purpose of avoiding possible ionization if higher stresses were permitted. For acceptance testing, the stress and time of electrification should be mutually agreed upon by the purchaser and the seller. The time of electrification in general usage is 1 min.

NOTE 4—The dc volume resistivity of new oil, particularly at room temperature, has been shown to be a function of both electrical stress and electrode spacing. The resistivity has been found to have a maximum value when the applied electrical stress is about 50 V/mil; electrical stresses either below or above this critical value yield lower values of volume resistivity.^{6,7}

14. Conditioning

14.1 Store the sample in its original sealed container and shield it from light. Some liquids, such as oils of petroleum origin, undergo changes when exposed to sunlight. Allow the sealed container to stand undisturbed, in the room in which the test is to be made, for a sufficient period of time to permit the sample to attain room temperature before it is opened.

15. Storing Test Cell

15.1 Clean and dry the test cell, when not in use, in accordance with Section 16. Store it in a dust-free cabinet until it is to be used again, at which time clean and dry as directed by Section 16.

16. Cleaning Test Cell

16.1 The cleanliness of the test cell is of paramount importance when making resistivity measurements because of the inherent susceptibility of most insulating liquids to contaminating influences of the most minute nature. For this reason clean and dry the cell immediately prior to making the test. It is essential that the procedures and precautions outlined in 16.2-16.5 be strictly observed.

⁶ Gänger, B., and Maier, G., “The Resistivity of Insulating Oil in a Direct Voltage Field,” *Brown-Boveri Review*, Vol 56, October 1969, pp. 525-533.

⁷ Harrison, N. L., “Resistivity of Transformer Oil at Low and Medium Field Strengths,” *Proceedings IEEE, IEEEA*, Vol 115, May 1968, pp. 736-741.

⁵ Information as to where these cells can be purchased and working drawings of them may be obtained from ASTM, 100 Barr Harbor Drive, PO Box C700, West Conshohocken, PA 19428-2959. Request ADJD092401.

16.2 Dismantle the cell completely and wash all the component parts thoroughly with a technical grade of a suitable solvent (such as acetone or pentane). Wash the component parts with a mild abrasive soap or detergent. Take care not to lay the electrodes on any surface. Rinse all parts thoroughly with hot tap water, then with cold tap water, followed by several rinsings with distilled water. Take extreme care during the washing and rinsing of the test cell shown in Fig. 2 to prevent any moisture from entering the thermometer well in the inner electrode. As a precaution against this eventuality, use a suitable stopper to plug this opening prior to starting the cleaning operation.

16.3 After the surfaces of the electrodes and guard have been washed, take care not to touch these surfaces during the rinsing or any subsequent operation.

16.4 Place the component parts of the test cell in an oven maintained at 110°C for a period of not less than 60 min. Do not dry test cells made of Monel at this elevated temperature for more than 90 min as oxidation will take place, causing erroneous results. Take care to place the component parts of the cell on a clean surface of the oven.

16.5 At the expiration of the drying period, assemble the cell in the oven, using clean cotton gloves to protect the hands. Observe the precaution given in 16.3.

16.6 Quickly transfer the assembled test cell to the test chamber maintained at a temperature above the desired test temperature. The exact temperature will depend on both the oven and the cell design. The test chamber shall be such that when the oil, preheated to 2°C below the test temperature, is transferred to the cell, the test temperature is attained and maintained within 20 min.

PROCEDURE FOR MAKING REFEREE TESTS

17. Preparation of Test Specimen and Filling Test Cell

17.1 Use only a three-terminal cell for these tests.

17.2 When insulating liquids are heated to elevated temperatures, some of their characteristics undergo a change with time, and the change, even though of the minutest nature, may be reflected in the resistivity results. It is therefore desired that the elapsed time necessary for the test specimen to attain temperature equilibrium with the test cell be held to a minimum. For optimum procedure do not exceed 20 min for this time. It is essential therefore that the procedure outlined in 17.4-17.7 be closely followed.

17.3 When the resistivity test is to be made subsequent to the ac loss characteristic measurement, it follows that the precautions to be observed in preparation of the test specimen and filling the test cell have already been met. In the event, however, that the resistivity test is to be made without making the a-c loss characteristic measurement, use the procedure for preparation of the test specimen and filling the test cell outlined in 17.4-17.7.

17.4 In order that representative test specimens may be obtained, gently tilt or invert the sample container and swirl the fluid several times. Immediately after mixing the sample, pour a quantity of fluid sufficient for four fillings of the test cell into a chemically clean, dry beaker and heat on a hot plate to a temperature 2° below the desired test temperature. During the

heating period, stir the fluid frequently.

17.5 Remove the cell from the test oven, lift out the inner electrode, but do not rest it on any surface, and fill the cell with a portion of the heated sample. Replace the beaker with the remainder of the heated sample on the hot plate. Insert the inner electrode and rinse the electrodes by twice raising and lowering the inner electrode. Remove the inner electrode and hold it suspended in air; then decant the rinsing fluid and immediately fill the cell from the remainder of the heated sample. Replace the inner electrode.

17.6 Insert a mercury thermometer (**Caution**, see Note 5), graduated in 0.25°C increments, in the thermometer well provided in the inner electrode. Immediately return the filled cell to the test chamber (adjusted to a temperature of 5°C above the desired test temperature) and make the necessary electrical connections to the cell.

NOTE 5—Caution: A spring-loaded thermocouple may be used for measuring the temperature of the inner electrode, but extreme caution shall be exercised that these wires do not come in contact with the voltage supply lead and do not pick up stray emf's.

17.7 Perform the operations described in 17.5 and 17.6 as rapidly as possible.

NOTE 6—After much experimenting, the above technique has been evolved to give the most reproducible results for tests at 100°C. Little experience has been obtained from tests at higher temperatures. However, individual laboratories engaged in work at temperatures above 100°C have probably developed their own technique.

18. Procedure

18.1 Make the resistivity measurements while the temperature of the inner electrode is within $\pm 0.5^\circ\text{C}$ of the desired test temperature. If a power factor test has been made on the test specimen, short-circuit the cell electrodes for 1 min, then start the resistivity measurements immediately thereafter.

18.2 In making the initial measurement, apply “direct polarity” of the potential to the test specimen and at the end of 1 min of electrification record the current and voltage measurements. Short-circuit the test cell electrodes for a period of 5 min. Calculate the resistivity (see Section 27).

18.3 At the end of the 5-min period, remove the short-circuit from the electrodes, then apply “reverse polarity” of the potential to the test specimen. At the end of 1 min record the current and voltage measurements and calculate the resistivity. Average the resistivity values obtained from the “direct” and “reverse” polarity measurements.

18.4 Pour off the liquid in the test cell and without rinsing again fill the test cell with a second test specimen from the heated sample and take another set of measurements as outlined in 18.2 and 18.3.

18.5 If the difference in the resistivity values of the two test specimens is within 20 % of the higher of the two values, no further tests are required and report the average of the two test specimens as the resistivity of the sample. If the difference in the values of the two test specimens is not within 20 %, test a third specimen. If the difference in the values between any two of the three test specimens is not within 20 %, clean the test cell and test specimens from another sample until the difference in the resistivity of two test specimens is within 20 %.

18.6 When the dissipation factor or power factor measurements on test specimens from a sample are not within the limits specified in Test Method D 924, do not report the results of resistivity measurements on these test specimens (if made) and repeat the test when resamples are obtained.

PERMISSIBLE MODIFICATIONS WHEN MAKING ROUTINE TESTS

19. General

19.1 When it is desired to get an approximation of the resistivity of a test specimen or to make tests on a group of test specimens of the *same* type of insulating fluid to ascertain whether the resistivity is greater or less than some specified value, certain modifications to Sections 17 and 18 are permitted as outlined in the following sections.

20. Test Cell

20.1 Any test cell conforming to the requirements given in the Annex may be used. For routine tests, however, the requirements for a guard electrode may be waived provided that the two-electrode cell used is of adequate capacitance and with sufficient ratio of surface area to specimen thickness to provide proper operation of the measuring equipment. One such cell is shown in Fig. A1.4.

21. Test Chamber

21.1 An oil bath having uniform temperature distribution and provided with adequate temperature regulation may be used for routine tests, provided that, when the test cell is immersed in the bath, the temperature difference in the test cell between any part of the inner electrode and the outer electrode does not exceed 2°C. A less satisfactory method is the use of a hot plate, but variations in temperature throughout the cell may lead to questionable results. In general, the use of a forced-draft air test chamber is preferable.

22. Test Temperature

22.1 Resistivity measurements may be made when the test specimen is within $\pm 2.0^\circ\text{C}$ of the desired temperature.

23. Cleaning Test Cell

23.1 Since some two-electrode cells cannot be dismantled, the cleaning procedure given in Section 16 cannot always be followed. Where this applies, it is imperative that each laboratory evolves a good cleaning procedure for the cell used so that repeatable results can be obtained. Only solvents mentioned in 16.2 are satisfactory as cleaning agents.

23.2 When a number of test specimens of the *same* type of fluid are to be tested consecutively, the same test cell may be used without cleaning, provided that the resistivity of the test specimen previously tested was greater than the specified value. If the resistivity of the last test specimen tested was less than the specified value, clean the test cell before using for further tests.

24. Procedure

24.1 Because of the difference in construction of the various types of test cells that may be used for routine tests, no detailed procedure for preparation of the test specimen and filling of the test cell is given. Give due regard to the precautions outlined in Section 17.

24.2 Before filling, always rinse the test cell with a portion of the test specimen to be tested.

25. Electrical Connection

25.1 When making electrical connection to a two-electrode cell, the shield on the lead usually connected to the guard electrode (see Fig. 1) shall be securely clipped to the TFE-fluorocarbon insulation in order to prevent contact with any surface.

26. Number of Tests

26.1 Only a single test specimen need be tested in measuring the resistivity of a sample.

27. Calculation

27.1 Calculate the resistivity of a test specimen, ρ , in units of 10^{12} ohm-centimetres, by using one of the following equations, depending on whether the galvanometer or picoammeter was connected in the test circuit:

27.1.1 Using the galvanometer for current measurement:

$$\rho = (E [m]P5 K)/(D [m]P5 G_s)$$

27.1.2 Using the picoammeter for current measurement:

$$\rho = (E [m]P5 K)/I$$

where:

E = test voltage, V

K = cell constant, cm,

D = galvanometer deflection, in divisions,

G_s = galvanometer sensitivity, in picoamperes per division, and

I = current, picoamperes.

28. Report

28.1 Report the following information:

28.1.1 Specific resistance (resistivity) of the sample,

28.1.2 Type of cell used,

28.1.3 Method of measurement,

28.1.4 Average voltage gradient in the sample while under test in volts per mil (or volts per millimetre),

28.1.5 Temperature of the sample while under test,

28.1.6 Temperature and humidity of the room during test.

28.2 Use the following table as a guide in reporting the values of resistivity:

ρ , (10^{12} Ω -cm)	Report Value to:
500 or greater	nearest 50
100 or greater, but less than 500	nearest 10
10 or greater, but less than 100	nearest integer
Less than 10	two significant figures

29. Precision and Bias

29.1 *Precision*—Repeatability and reproducibility cannot be developed for this procedure due to an insufficient number of participants in the most recent round robin and the incompleteness of the data. Work is being performed to collect data from several laboratories.

29.2 *Bias*—Since there is no accepted reference material suitable for determining the bias, no statement can be made at this time.

30. Keywords

30.1 resistivity; specific resistance

ANNEX

(Mandatory Information)

A1. CELLS USED FOR MEASURING SPECIFIC RESISTANCE (RESISTIVITY) OF ELECTRICAL INSULATING LIQUIDS

A1.1 *Design of Cell*—A cell for the purpose of measuring the specific resistance (resistivity) of electrical insulating liquids should meet the following general requirements:

A1.1.1 The design of the cell shall be such as to facilitate easy and thorough cleaning of its component parts, permit the use of the cell in a suitable temperature bath, and provide means for measuring the temperature of the liquid under tests.

A1.1.2 The materials used in constructing the cell shall be nonporous and capable of satisfactorily withstanding the temperature to which the cell will be subjected under test. The alignment of the electrodes shall not be influenced by this temperature nor by the operation of filling the cell with the test liquid.

A1.1.3 The electrodes or their surfaces shall be made of a metal capable of resisting attack by mild acids such as are found in oils of petroleum origin, particularly after prolonged exposure at elevated temperatures. Metals that have been found satisfactory from this standpoint are gold, nickel, Monel, platinum, and stainless steel. Plated surfaces that may be satisfactory for short periods of time for testing liquids having low acidity are gold, platinum, nickel, chromium over nickel, or rhodium.

A1.1.4 In order to achieve a high order of accuracy in determining the resistivity, a guard electrode shall be provided which adequately shields the measuring electrode. A shielded wire or coaxial cable shall be used to connect the guard and measuring electrodes, either directly or by a plug to the measuring circuit.

A1.1.5 The solid insulation used to support the guard electrode relative to the measuring electrode shall not extend into the portion of the sample being tested.

A1.1.6 The insulating materials used in constructing the cell shall not absorb or be adversely affected by the test liquids or cleaning solvents. The insulation resistance of these insulating materials must necessarily be high, particularly that between the guard and the measuring electrodes. Insulating materials that have proven satisfactory are boron nitride, borosilicate glass, quartz, steatite, and TFE-fluorocarbon. Thermoplastic materials such as hard rubber and polystyrene, although having good electrical properties, are not suitable as they soften below 130°C. Insulating materials of the molded mica-dust type have been found to absorb solvents and therefore are not considered as satisfactory in the measurement of liquids having high resistivity values.

A1.1.7 In designing the cell, the distance across the surface of the test specimen and across the solid insulating material between the guard and the measuring electrode shall be great enough to withstand adequately the test potential used. Leakage across these paths has been found to produce erroneous results.

A1.1.8 The surface area of the measuring electrode and the

gap spacing between the measuring electrode and the high-voltage electrode shall be such that the ratio of surface area to the thickness of the test specimen shall be large enough to provide sufficient current for adequate operation of the measuring equipment. It is required, however, that the precision of the measurements meet the intended accuracy of this method.

A1.2 *Recommended Test Cells*—Four cells that have been found suitable for measuring the resistivity of electrical insulating materials are shown in Fig. A1.1, Fig. A1.2, Fig. A1.3, and Fig. A1.4. The following is a description of each:

A1.2.1 *Figure A1.1*⁸—The cell shown in Fig. A1.1 is a three-terminal cell. It is made of Monel, its volume is 185 mL, its capacitance with air as the dielectric is approximately 75 pF, and it is suitable for use at voltages up to 5 kV and temperatures up to 150°C.

A1.2.2 *Figure A1.2*⁹—The cell shown in Fig. A1.2 is a three-terminal cell, as well. It is made of stainless steel, its volume is 40 mL, it is suitable for use at voltages up to 3 kV, and temperatures up to 150°C. This cell has been proposed by the International Electrotechnical Commission for use as an international standard test cell.

⁸ Figure A1.1 is no longer commercially available.

⁹ Available from Avo International, 4651 South West Moreland Rd., Dallas, TX 75237 (Catalog No. 810200).

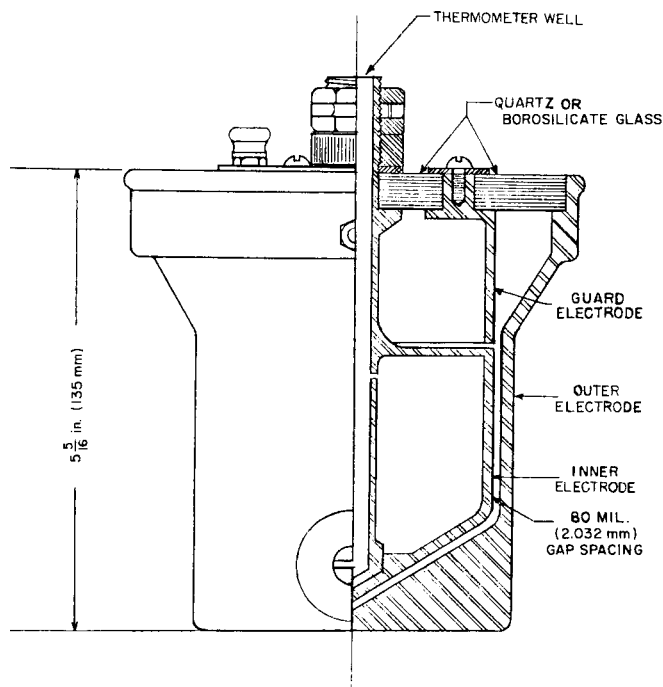

FIG. A1.1 Cell for Referee Tests

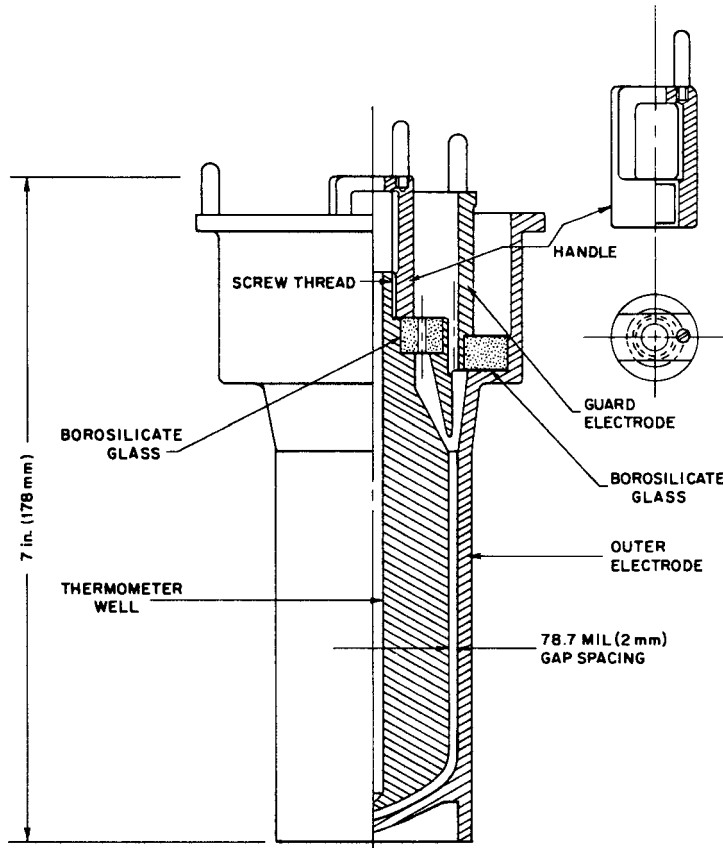

FIG. A1.2 Small-Capacity Cell for Referee Tests and Research Investigations

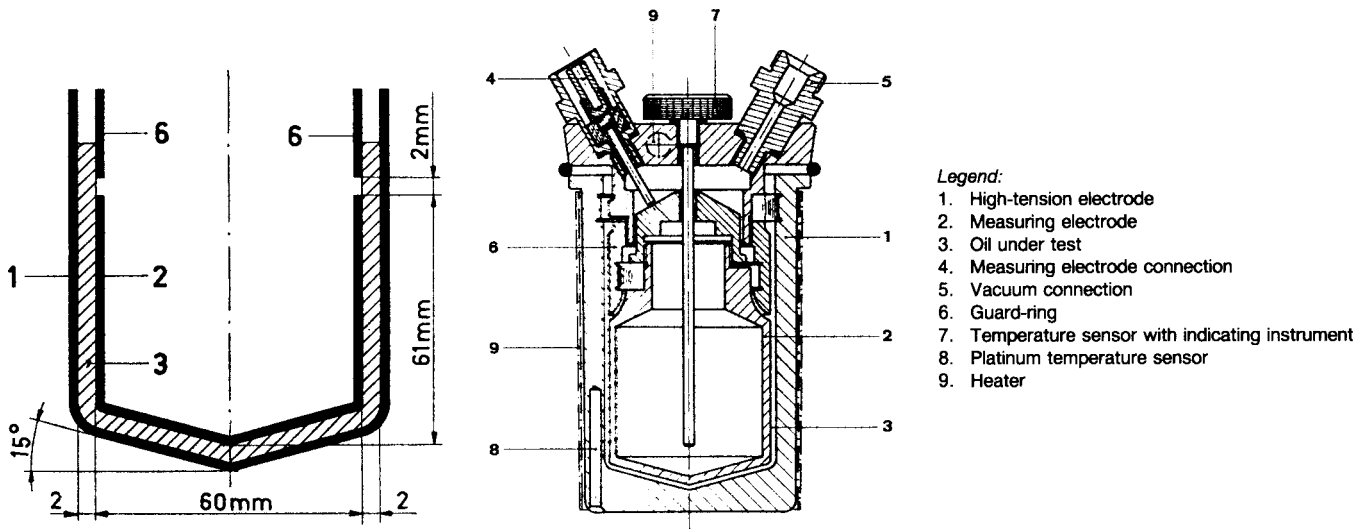

FIG. A1.3 Test Cell

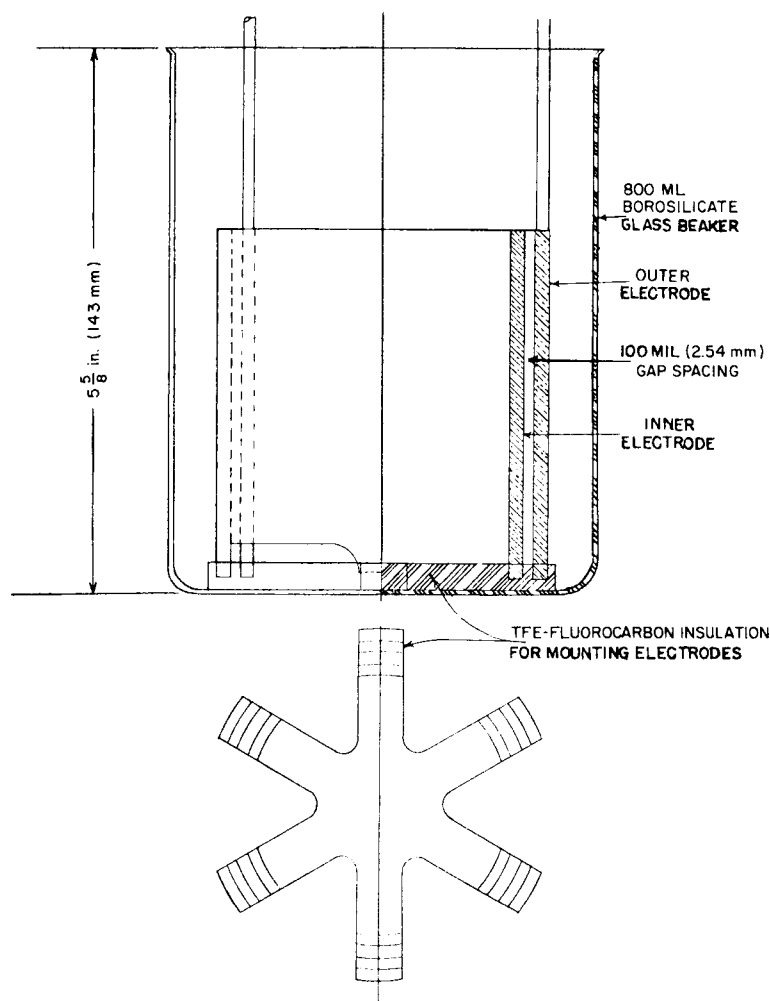

FIG. A1.4 Two-Electrode Cell for Routine Tests

A1.2.3 *Figure A1.3*¹⁰—The cell shown in Fig. A1.3 is a three-terminal cell, as well. It is made of stainless steel, the volume is 40 mL, and the capacitance with air as the dielectric is approximately 60 pF. The cell is suitable for use at voltages up to 2 kV and temperatures up to 150°C.

A1.2.4 *Figure A1.4*¹¹—The cell shown in Fig. A1.4 is a two-electrode cell intended solely for making routine tests where it is desired to ascertain whether a sample is greater or less than some specified value. The concentric cylinders are of nickel-plated brass which are mounted on a TFE-fluorocarbon base and contained in an 800-mL borosilicate glass beaker. The volume of oil required when using this cell is 500 mL. The cell is suitable for use at voltages up to 5 kV and temperatures up to 150°C.

¹⁰ Available from Tettex Instruments, Inc., P. O. Box 281, Fairview Village, PA 19409 (Model No. 2903). One cell not shown in the drawings that has been found suitable for resistivity tests is available from Rutherford Research, P. O. Box 249, Rutherford, NJ 07070.

¹¹ There is no known commercial source for the two-electrode cell shown in Fig. A1.4. Working drawings may be obtained from the ASTM, 100 Barr Harbor Drive, PO Box C700, West Conshohocken, PA 19428-2959. Request ADJD092404.

The American Society for Testing and Materials takes no position respecting the validity of any patent rights asserted in connection with any item mentioned in this standard. Users of this standard are expressly advised that determination of the validity of any such patent rights, and the risk of infringement of such rights, are entirely their own responsibility.

This standard is subject to revision at any time by the responsible technical committee and must be reviewed every five years and if not revised, either reapproved or withdrawn. Your comments are invited either for revision of this standard or for additional standards and should be addressed to ASTM Headquarters. Your comments will receive careful consideration at a meeting of the responsible technical committee, which you may attend. If you feel that your comments have not received a fair hearing you should make your views known to the ASTM Committee on Standards, at the address shown below.

This standard is copyrighted by ASTM, 100 Barr Harbor Drive, PO Box C700, West Conshohocken, PA 19428-2959, United States. Individual reprints (single or multiple copies) of this standard may be obtained by contacting ASTM at the above address or at 610-832-9585 (phone), 610-832-9555 (fax), or service@astm.org (e-mail); or through the ASTM website (www.astm.org).