



Standard Guide for Core Sampling Submerged, Unconsolidated Sediments¹

This standard is issued under the fixed designation D 4823; the number immediately following the designation indicates the year of original adoption or, in the case of revision, the year of last revision. A number in parentheses indicates the year of last reapproval. A superscript epsilon (ϵ) indicates an editorial change since the last revision or reapproval.

^{ε1} NOTE—Warning notes were editorially moved into the standard text in August 2003.

1. Scope

1.1 This guide covers core-sampling terminology, advantages and disadvantages of different types of core samplers, core-distortions that may occur during sampling, techniques for detecting and minimizing core distortions, and methods for dissecting and preserving sediment cores.

1.2 In this guide, sampling procedures and equipment are divided into the following categories based on water depth: sampling in depths shallower than 0.5 m, sampling in depths between 0.5 m and 10 m, and sampling in depths exceeding 10 m. Each category is divided into two sections: equipment for collecting short cores and equipment for collecting long cores.

1.3 This guide emphasizes general principles. Only in a few instances are step-by-step instructions given. Because core sampling is a field-based operation, methods and equipment must usually be modified to suit local conditions. This modification process requires two essential ingredients: operator skill and judgment. Neither can be replaced by written rules.

1.4 Drawings of samplers are included to show sizes and proportions. These samplers are offered primarily as examples (or generic representations) of equipment that can be purchased commercially or built from plans in technical journals.

1.5 This guide is a brief summary of published scientific articles and engineering reports. These references are listed in this guide. These documents provide operational details that are not given in this guide but are nevertheless essential to the successful planning and completion of core sampling projects.

1.6 *This standard does not purport to address all of the safety concerns, if any, associated with its use. It is the responsibility of the user of this standard to establish appropriate safety and health practices and determine the applicability of regulatory limitations prior to use.* For specific warning statements, see 6.3 and 11.5.

2. Referenced Documents

2.1 ASTM Standards:

D 420 Guide to Site Characterization for Engineering, De-

sign, and Construction Purposes²

D 1129 Terminology Relating to Water³

D 1452 Practice for Soil Investigation and Sampling by Auger Borings²

D 1586 Test Method for Penetration Test and Split-Barrel Sampling of Soils²

D 1587 Practice for Thin-Walled Tube Sampling for Geotechnical Purposes²

D 4220 Practices for Preserving and Transporting Soil Samples²

D 4410 Terminology for Fluvial Sediment³

3. Terminology

3.1 *Definitions*—For definitions of terms used in this guide, refer to Terminology D 1129 and Terminology D 4410.

3.2 *Definitions of Terms Specific to This Standard:*

3.2.1 *check valve*—a device (see Fig. 1)⁴ mounted atop an open-barrel core sampler. As the sampler moves down through water and sediment, the valve remains open to allow water to flow up through the barrel. When downward motion stops, the valve closes. During retrieval, the valve remains closed and creates suction that holds the core inside the barrel.

3.2.2 *core*—a vertical column of sediment cut from a parent deposit.

3.2.3 *core catcher*—a device (see Fig. 2) that grips and supports the core while the sampler is being pulled from the sediment and hoisted to the water surface.

3.2.4 *core conveyor*—a device (see Fig. 3) for reducing friction between a core and the inside surface of a core barrel.

3.2.5 *core-barrel liner*—a rigid, thin-wall tube mounted inside the barrel of a core sampler. During the core-cutting process, sediment moves up inside the liner.

3.2.6 *core sampler*—an instrument for collecting cores.

3.2.7 *extrude*—The act of pushing a core from a core barrel or a core-barrel liner.

3.2.8 *open-barrel sampler*—in simplest form, a straight tube open at both ends. More elaborate open-barrel samplers have core catchers and check valves.

¹ This guide is under the jurisdiction of ASTM Committee D19 on Water and is the direct responsibility of Subcommittee D19.07 on Sediments, Geomorphology, and Open-Channel Flow.

Current edition approved June 10, 2003. Published August 2003. Originally approved in 1988. Last previous edition approved in 1999 as D 4823 – 95 (1999).

² *Annual Book of ASTM Standards*, Vol 04.08.

³ *Annual Book of ASTM Standards*, Vol 11.01.

⁴ The boldface numbers in parentheses refer to the list of references at the end of this guide.

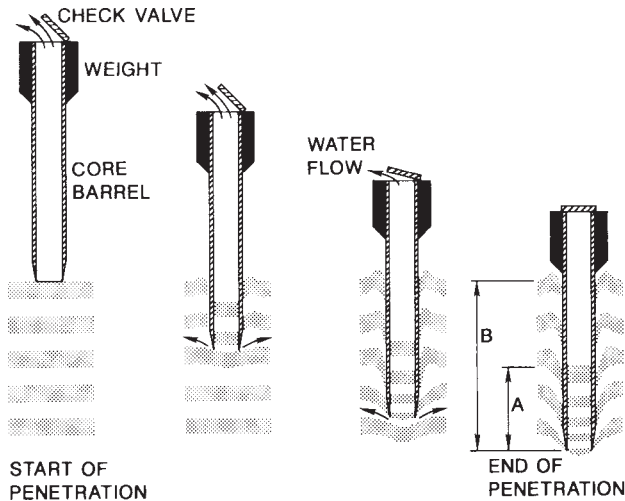

NOTE—Dark bands represent stiff sediments; light bands represent plastic sediments. As coring proceeds, sediment below the barrel moves laterally away from the cutting edge and plastic sediments inside the barrel are compressed. “A” is the core’s length and “B” is the barrel’s penetration depth.

FIG. 1 Deformations Caused by Open-Barrel Core Samplers (1)⁴

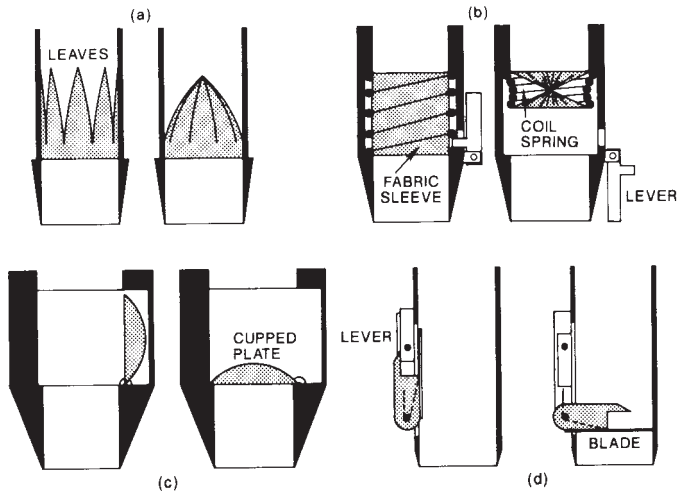

NOTE—(a) The leaves separate during penetration and then close during retrieval. Strips of gauze can be woven around the leaves to provide additional support. (3) (b) The lever trips down during retrieval to release the spring and twist the fabric sleeve shut. (4) (c) The cupped plate drops during retrieval to block the entrance and support the core. (4) (d) The lever releases the spring-loaded blade which pivots downward to hold the core. (4)

FIG. 2 Core Catchers

3.2.9 *piston immobilizer*—a special coupling (see Fig. 4) that protects a core from disruptive forces that arise during sampler pull-out. Piston immobilizers are also called *split pistons* or *break-away pistons*.

3.2.10 *piston sampler*—a core sampler (see Fig. 5) with a solid cylinder (piston) that seals against the inside walls of the core barrel. The piston remains fixed at the bed-surface elevation while the core barrel cuts down through the sediment.

3.2.11 *recovery ratio*—the ratio A/B where “A” (see Fig. 1) is the distance from the top of the sediment core to the bottom

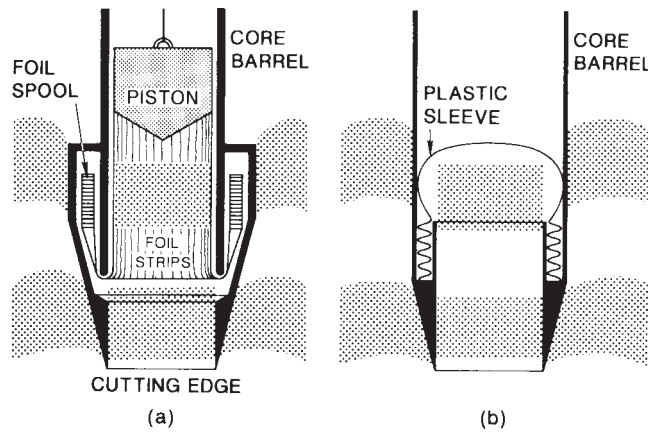

NOTE—(a) Strips of metal foil slide up through the core barrel as the cutting edge advances downward. (5) (b) The plastic sleeve unfolds from pleats stored near the cutting edge. This sleeve surrounds the core as the barrel moves down. (4)

FIG. 3 Core Conveyors

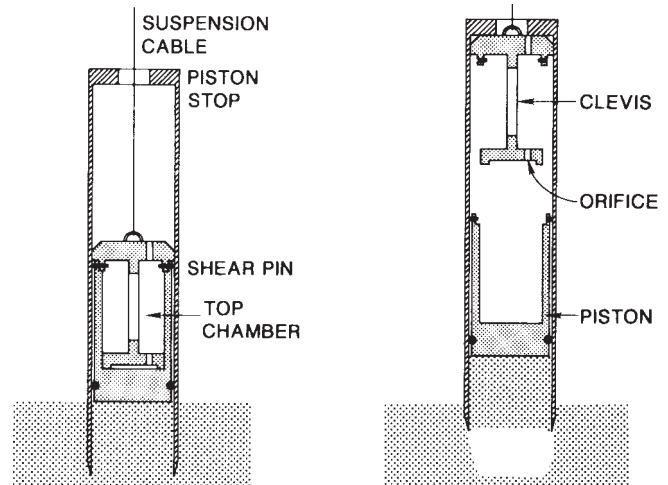

NOTE—During penetration the shear pins break but the flow-restricting orifice holds the clevis and piston together. During retrieval, water in the top chamber flows through the orifice and allows the piston and clevis to separate. Cable tension pulls the clevis up against the stop but friction locks the piston and core barrel together.

FIG. 4 Piston Immobilizer (9)

of the cutting bit and “B” is the distance from the surface of the parent deposit to the bottom of the cutting bit.

3.2.12 *repenetration*—a mishap that occurs when a core sampler collects two or more cores during one pass.

3.2.13 *surface sampler*—a device for collecting sediment from the surface of a submerged deposit. Surface samplers are sometimes referred to as grab samplers.

3.2.14 *trip release*—a mechanism (see Fig. 5 and Fig. 6(b)) that releases a core sampler from its suspension cable and allows the sampler to freely fall a predetermined distance before striking the bed.

3.2.15 *undisturbed sample*—sediment particles that have not been rearranged relative to one another by the process used to cut and isolate the particles from their parent deposit. All core samples are disturbed to some degree because raising the

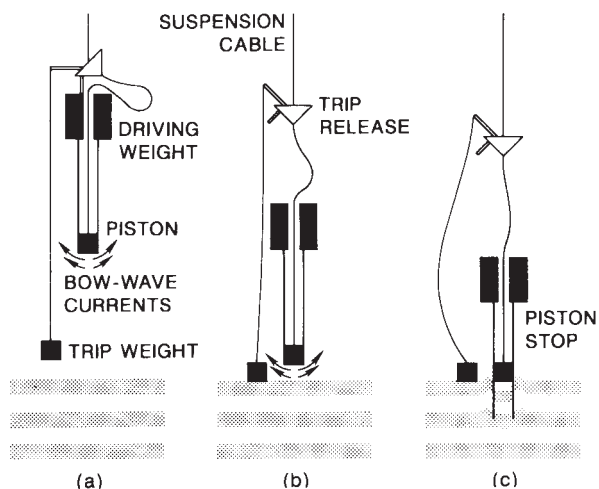

NOTE—(a) The sampler is lowered slowly through the water. (b) The sampler falls free when the trip weight contacts the bed. (c) The core barrel cuts downward but the piston remains stationary.

FIG. 5 Operation of a Piston-Type Core Sampler (2)

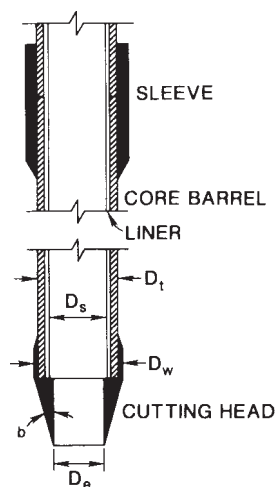

FIG. 7 Critical Dimensions for Cutting Bits and Core Barrels (11)

4.2 *Cutting-Bit Angle*—The angle “b” on the cutting bit (see Fig. 7) should be less than about 10°; the optimum angle is about 5°. If the angle is smaller than about 2°, the bit cuts efficiently but its edge chips and dulls easily.

4.3 *Core-Liner Diameter, D_s* (see Fig. 7)— D_s should be larger than about 5 cm; however, the upper limit for D_s is difficult to establish. As D_s increases, the amount of core compaction decreases but the sampler becomes heavier and larger. A survey of existing samplers shows that 10 cm is a practical upper limit. A few samplers have barrels larger than 10 cm but these are used only for special applications (12).

4.4 *Inside Friction Factor*—The dimensions D_s and D_e (see Fig. 7) set the inside friction factor defined as $C_i = (D_s - D_e)100/D_e$. For a barrel without a core conveyor, the optimum C_i value depends mainly on the barrel’s length. C_i should be smaller than 0.5 if the barrel is shorter than about 2 m. If the barrel is longer than about 2 m, C_i should fall between 0.75 and 1.5. For a barrel with a core conveyor, C_i should be smaller than 0.5 regardless of the barrel’s length. Notice that in all instances D_s is lightly greater than D_e . The small expansion above the cutting bit minimizes friction where the outside of the core contacts the inside of the barrel or liner. Friction distorts the core’s strata by bending horizontal layers into curved, bowl-shaped surfaces shown on the upper part of Fig. 8. Friction also causes overall end-to-end compaction of the core and thereby reduces recovery ratios. If friction becomes very large, sediment fails to enter the cutting bit. Instead, sediment moves aside as the bit penetrates downward. This lateral motion, commonly referred to as “staging,” prevents deep-lying strata from being sampled. It is important to observe upper limits on C_i because too large an expansion causes another form of distortion, the core slumps against the walls as the sediment slides up into the barrel.

4.5 *Outside Friction Factor*—The dimensions D_w and D_t (see Fig. 7) set the outside friction factor defined as $C_o = (D_w - D_t)100/D_t$. C_o should be zero for barrels used in cohesionless sediments; but C_o should be between 1.0 and about 3.0 for barrels used in cohesive sediments. Notice that in all instances D_w is larger than D_t . The small contraction above the bit reduces friction at the outside surface of the barrel and makes

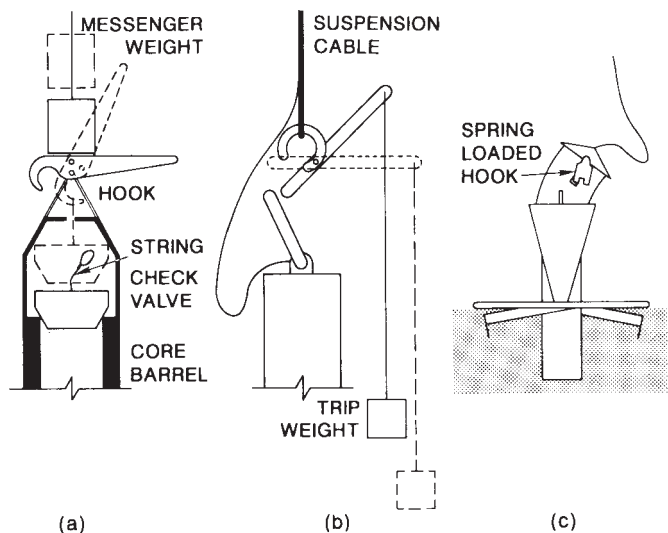

NOTE—(a) The messenger weight strikes the hook and releases the string holding the check valve. (6) (b) The trip weight strikes the sediment and unhooks the sampler. (7) (c) The cable slackens and allows the spring-loaded hook to open. (8)

FIG. 6 Release Mechanism

cores to the water surface causes pore water and trapped gases to expand (10). In common usage, the term “undisturbed sample” describes particles that have been rearranged but only to a slight degree.

4. Critical Dimensions of Open-Barrel and Piston Samplers

4.1 Dimensions of a sampler’s cutting bit, core tube, and core-tube liner (see Fig. 7) are critical in applications requiring undisturbed samples. These dimensions control the amount of distortion in recovered cores. The recommendations in this section were developed from tests on open-barrel core samplers (11); however, the recommendations are usually extended to cover piston-type core samplers.

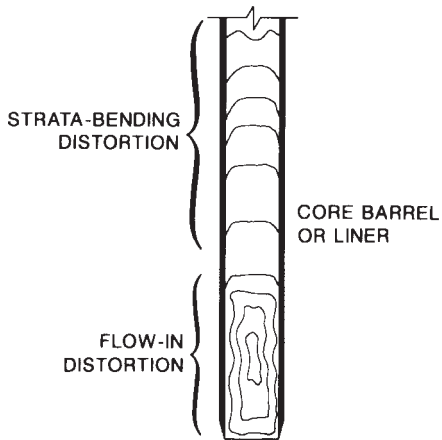

FIG. 8 Flow in and Strata-Bending Distortions Inside a Core Barrel (13)

it easier to push the core barrel into the bed. On a long barrel, friction can be reduced by installing one or more sleeves (see Fig. 7). The sleeves not only plough a path for the barrel but they also serve as clamps to hold barrel sections together.

4.6 *Area Factor*—The dimensions D_w and D_e set the area factor defined as $C_a = (D_w^2) 100/D_e^2$. C_a should be less than 10 or possibly 15. Notice that C_a is proportional to the area of sediment displaced by the bit divided by the area of the bit's entrance; therefore, C_a is an index of disturbance at the cutting edge. A sampler with too large an area factor tends to oversample during early stages of penetration when friction along the inner wall of the barrel is low. Oversampling occurs because sediment laying below and outside the bit shift inward as the bit cuts downward.

4.7 *Core-Barrel Length*—A sampler's core barrel should be slightly longer than L , the longest core that can be collected without causing significant compaction. L and D_s (see Fig. 7) set the core-length factor defined as $L_f = L/D_s$. L_f should be less than 5.0 (or possibly 10) for a sampler used in cohesive sediments, but L_f should be less than 10 (or possibly 20) for a sampler used in cohesionless sediments. The constant factors 5, 10, and 20 apply to slow-penetrating, open-barrel samplers. Studies suggest that all of these factors can be increased by raising the sampler's penetration speed or using a piston sampler instead of an open-barrel sampler.

4.8 *Barrel Surfaces*—All surfaces contacting the core should be smooth and free of protruding edges to reduce internal friction and minimize core distortion. The surfaces should also be clean and chemically inert if the core is to be analyzed for contaminants or if the core is to be stored in its liner for long periods of time.

4.9 *Chemical Composition of Sampler Parts*—Sampler parts must not contain substances that interfere with chemical analysis of the cores. For example, barrels, pistons, and core catchers made of plastic should not be used if tests include phthalate concentrations. Misleading data will result from plasticizer contamination of the sediments.

5. Open-Barrel Samplers Versus Piston Samplers

5.1 Users sometimes face difficult decisions in choosing between an open-barrel sampler and a piston sampler. The

decision frequently depends not only upon characteristics of the two samplers but also upon other factors such as hoisting-equipment capabilities, working platform stability, water depth, operator experience, and the purpose for collecting the cores. This section covers factors to consider before making the final choice.

5.2 *Depth of Penetration*—Most open-barrel samplers and most piston samplers rely on momentum to drive their barrels into sediment deposits. Momentum-driven samplers are released at a predetermined point so as to acquire momentum while falling toward the bed. A momentum-driven piston sampler generally penetrates deeper than a momentum-driven open-barrel sampler provided the two samplers have equal weights, equal barrel-diameters, and equal fall-distances (2).

5.3 *Core Compaction*—When compared under equal test conditions (see 5.2), a piston sampler causes less core compaction than an open-barrel sampler. However, the piston must be held motionless at the bed-surface elevation while the barrel penetrates downward. If the piston is allowed to shift down with the barrel, the core undergoes serious compaction.

5.4 *Flow-in Distortion*—Flow-in distortion is caused by suction at the entrance of a sampler. Sediment is sucked into the barrel instead of being severed and encircled by the cutting edge. Flow-in rarely occurs with open-barrel samplers; however, it can be a problem with piston samplers (14). Flow-in usually occurs during pull-out following a shallow penetration. Conditions leading to flow-in are shown in Fig. 5(c). The barrel is at the end of its downward travel but the piston lies below the piston stop. During pull-out, the upward force on the cable slides the piston up through the barrel before the cutting edge clears the bed. As the piston slides, it pulls the core up through the barrel. As the core moves, sediment flows in to fill the void at the lower end of the barrel. Strata lines at the bottom of the recovered core are distorted and resemble those in Fig. 8. A piston immobilizer helps prevent flow-in distortion by breaking the connection between the cable and the piston during the pull-out process.

5.5 *Surface Disturbance*—Surface sediment, material lying at the interface between water and bed, is easily disturbed by bow-wave currents (see Fig. 5(a)) that travel ahead of a sampler's cutting bit. A piston sampler creates a strong bow wave as the barrel, which is blocked by the piston, falls through the water. Fine-grained, unconsolidated sediments are blown aside just before the cutting edge contacts the bed. An open-barrel sampler creates a weak bow-wave because the barrel is unobstructed. However, adding a core catcher or a check valve to an open-barrel sampler restricts water flow through the barrel and makes the bow-wave stronger. Check valves come in a variety of sizes, shapes, and styles. These characteristics should be carefully considered before making a final selection. The valve should have an opening approximately equal to the cross-sectional area of the barrel. The valve should open fully during the sampler's descent and then close and seal tightly during the sampler's ascent.

5.6 *Repenetration*—Repenetration occasionally occurs in shallow-water sampling if the working platform (boat or barge) rolls and heaves; however, repenetration usually occurs in deep-water sampling that requires a long cable (1). During the

initial stage of pull out, the cable stretches as tension gradually increases. Suddenly, the sediment relaxes its grip on the barrel and the lower section of cable contracts as the sampler springs upward. A rapid sequence of events follow. A shock wave races up the cable, reflects off the hoist drum, and then travels back down to the sampler (15). Upon reaching the bottom, the shock wave abruptly lowers the sampler and the cutting bit cores the top layer of sediment a second time. This up and down bobbing action may occur several times before the sampler can be hoisted to a safe level above the bed. The severity of re-penetration depends on the type of sampler used. With an open-barrel sampler, the first core that is cut can shift up the barrel and easily escape through the check valve as additional cores enter the bit. With a piston sampler, the first core fills the barrel if the sampler cuts to full penetration. Since the first core cannot move past the piston, the sampler offers high resistance to re-penetration.

6. Driving Core Samplers into Sediment Deposits

6.1 Two techniques are frequently used to drive core samplers into sediment deposits. One technique depends entirely on weight. A weight-driven sampler is lowered slowly until friction along the barrel wall stops downward penetration. The other technique is based on momentum. A momentum-driven sampler is dropped from a specified height by a trip-release mechanism. As the sampler falls, it gains momentum that drives the barrel into the deposit. Paragraphs 6.2-6.6 cover other driving techniques that are occasionally used in special situations.

6.2 “Free” Core Samplers—Operation of a “free” core sampler, sometimes referred to as a “boomerang-core sampler” or a “free-fall corer” is shown in Fig. 9. The sampler is dropped into the water and then gains speed and momentum by falling through the entire water column (see Fig. 9(a)). After the core barrel has reached full penetration (see Fig. 9(b)), a latch (not shown) disconnects the core barrel and float from the heavily weighted lower section (Fig. 9(c)). The lower section remains on the bed; however, the float, core barrel, and core sample rise

to the water surface (Fig. 9(d)) where they are retrieved. Free corers are useful if many samples must be collected rapidly. Free cores are costly to operate because the lower sections must be replaced and because the latches sometimes fail.

6.3 Implosive and Explosive Samplers—These samplers are driven by high pressures developed by either implosions or explosions (16). An implosive-driven sampler has an electrically operated valve and a cylindrical cavity fitted with a piston. The sampler is lowered to the bed, then the valve is opened so that high-pressure water around the sampler can rush into the cavity and push against the piston. As the piston slides, it pulls against cables (or rods) which exert a downward thrust on the barrel and upward thrust on the sampler’s frame. Implosive samplers are complicated, expensive to purchase, and restricted to deep-water applications. However, the samplers have the advantage of being lighter than momentum-driven samplers. An explosive-driven sampler has a charge that detonates when the sampler touches bottom. The expanding gas produces a strong downward force on the core barrel. Using explosive-driven samplers has a redeeming feature in that they are lighter than momentum-driven samplers. (Warning—Because of the possibility of injury when using explosive samplers, it is suggested that specially trained personnel handle this apparatus.)

6.4 Punch-Corer Samplers—Punch corers are pushed downward by using a stiff rod connected to a jack, drill rig, or heavy weight. The samplers may be either open-barrel or piston types. Punch corers are commonly used in shallow water. Maximum operating depths are set primarily by the rigidity and length of the push rod. A sampling spud (Fig. 10) is a form of punch corer since the spud is pushed with a rod; however, the spud does not collect a true core sample. Instead, small specimens of sediment are trapped in the cup-shaped cavities. Color, softness, and grain-size profiles along the spud are approximate indexes of profiles in the sampled deposit.

6.5 Vibratory-Driven Samplers—High-frequency vibration helps to reduce friction on a core barrel. Sediment is pulsed away from the barrel, then the sampler advances downward a short distance pulsing and advancing alternates rapidly so that the barrel cuts downward at a nearly uniform rate. The vibrator

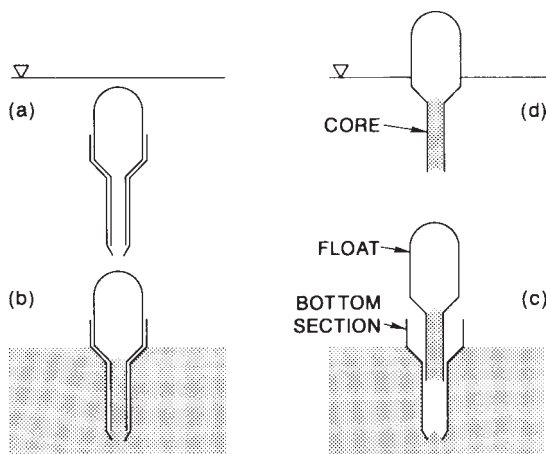

NOTE—(a) The sampler falls toward the bed. (b) The bottom section drives the core barrel into the sediment. (c) The bottom section unlatches and releases the float. (d) The float and core rise to the surface.

FIG. 9 Operation of a Free Corer (2)

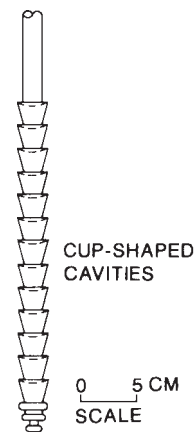

NOTE—The spud is pushed or driven into the sediment deposit. As the spud is pulled up, sediment becomes trapped in the cup-shaped cavities.

FIG. 10 Sampling Spud (17)

(see Fig. 11) which is fastened to the top end of the core barrel, receives power through an electric cable or compressed-air tube. Sediment grains inside the core are realigned by the vibration; however, compaction and strata-bending are nearly eliminated. Vibratory-driven samplers can be used through a broad range of water depths. According to Hubbell and Glenn (18), the samplers work especially well in sandy sediments that are difficult to penetrate with other types of core samplers.

6.6 *Impact-Driven Samplers*—Some gravity deposits that cannot be penetrated with open-ended barrels, can be pierced with pointed pipes (see Fig. 12(a)) driven with a heavy hammer. The pipes are filled with carbon-dioxide gas which slowly freezes the surrounding sediment. When freezing is complete, the pipes along with their load of frozen sediment are pulled free with a hoist suspended from a portable tripod.

7. Samplers for Specific Field Conditions

7.1 *Collecting Short Cores in Shallow Water:*

7.1.1 The Van Stratten sampler shown in Fig. 12(b) has been found satisfactory for the purpose of coring soft, cohesive sediments covered by water shallower than about 50 cm. This sampler is easy to make with a lathe and ordinary hand tools. The core barrel is a pipe with a diameter of about 10 cm and a length of about 60 cm. On thick-walled pipe, one end must be turned to form a sharp cutting edge: on thin-walled stove pipe, no sharpening is required. Scribe a vertical reference line on the outside surface if north-south alignment of the core is important in subsequent laboratory analysis. The stove-pipe has a seam that serves as a ready-made reference line. Glue a rubber sheet under the lid to form a water-tight seal with the pipe's upper edge. To use the sampler, first loosen the lid and align the reference mark. Then apply a steady pressure to force the sampler down into the sediment. Avoid hammering; it disturbs the core and usually fails to increase penetration. Holding the core inside the barrel during pullout is sometimes difficult. One solution is to excavate sediment from around the pipe and push a flat plate under the core. The pipe, plate, and core can then be lifted as a unit. Another solution is to fill the pipe brimful with water and then close and seal the lid. The suction formed during pullout helps to support the core.

7.1.2 The BMH-53 sampler shown in Fig. 12(c) has been found satisfactory for the purpose of coring sandy sediments

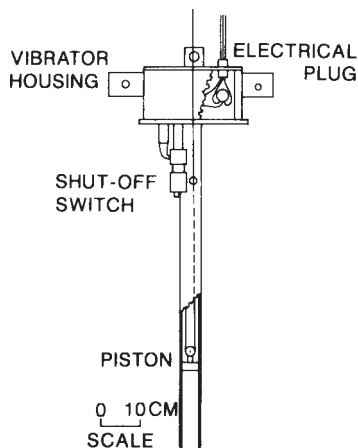
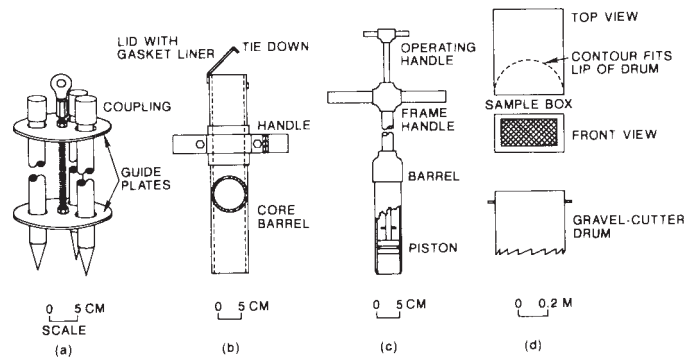

FIG. 11 Vibratory-Type Core Sampler (19)



NOTE 1—(a) The cryogenic-gravel sampler, a freeze-type sampler. (20) (b) The Van Stratten, an open-barrel sampler. (4) (c) The BMH-53, a piston sampler. (21) (d) The gravel-cutting sampler. (22)

NOTE 2—Fig. 12(b) has been reprinted from Bouma, A. H., *Methods for the Study of Sedimentary Structures*, 1969, with the permission of John Wiley and Sons, Inc., New York, NY.

FIG. 12 Core Samplers for Water Depths Less Than About 1/2 m

that are difficult to penetrate with the sampler shown in Fig. 12(b). A BMH-53 sampler is frequently used for sampling beds of wadeable rivers. The operating handle is connected to the piston and the frame handle is connected to the core barrel. Before collecting a sample, push the two handles together to set the piston flush with the barrel's cutting edge. Set the cutting edge against the bed and then cut the core by pressing down on the frame handle while holding the operating handle stationary. A slight rocking motion may be necessary to achieve full penetration and break the core loose from the bed. To retrieve the core, first grip the stem of the operating handle so that the piston cannot shift inside the barrel and then quickly lift the sampler above the water. To eject the core, push the handles together and catch the sediment in a clear carton. If the core slumps, it must be regarded as a highly disturbed sample.

7.1.3 Gravel beds can be sampled with the cryogenic sampler shown in Fig. 12(a). The pointed stainless-steel stakes are 1.3-m long sections of 2.5-cm pipe. Using a sledge, drive the stakes through holes in the guide plates and down into the bed. The flat guides hold the stakes upright and maintain a 7.6 cm spacing between centers. After all three stakes have been seated, connect the couplings to the manifold on a 9 kg CO₂ fire extinguisher fitted with a hand-wheel valve. When the valve is opened, cold CO₂ fills the pipes and freezes the sediment to the stakes. Lift the entire unit out of the bed with a hoist suspended from a portable tripod erected over the sampler. Collect subsamples of the stratified-sediment layers by first laying the stakes and frozen core across metal boxes placed side-by-side. About seven boxes, each 10 cm wide, are usually required. As the sediment thaws, particles fall into the boxes and are segregated according to position along the core. A blowtorch helps to speed the thawing process.

7.1.4 Another gravel-bed sampler is shown in Fig. 12(d). The gravel cutter, a 1/2-m diameter cylinder, is turned and pushed into the bed by hand. Serrations on the cutting edge help to plow through sand and gravel-size particles. When the cutter is in place, sediment is excavated layer-by-layer and placed in the sample box. If desired, samples can be sieved through the screened opening.

7.1.5 A lightweight sampler for use in shallow, cobblebed streams (36) can be made by removing both ends from a 30 gallon barrel. By pressing down on the cylinder formed by the barrel walls, a circular section of stream bed and the water column above it are isolated and shielded from the flow. Fine grains lying on or between the cobbles can then be lifted and entrained by circulating the trapped water through a small pump or, if milder agitation is preferred, by stirring with a large paddle. The suspended particles are then dip sampled with quart bottles. If the fine-grain deposits inside the barrel's footprint are thicker than about 10 mm, they can be sampled with a scoop. Next, the armoured surface layer is sampled by manually removing the particles within the circle formed by the drum's rim. To avoid sampling the subsurface layer, the operator starts at one point and makes only one traverse around the area. Particles lying under the rim are collected only if more than half their surface lies inside the circle. In the last phase, subsurface material is sampled to a depth of 0.15 to 0.30 m by using a stainless steel bowl. A prybar may be required to loosen large, tightly wedged particles.

7.1.6 To avoid losing fines when sampling flows that overtop the barrel, a bag (0.81-m wide by 1.5-m long) made from filter mesh having about 0.149 mm openings should be placed over the barrel's upper rim and secured with an elastic cord. A slit in the bag about 0.15 m long allows the operator to insert an arm and the necessary tools. Anchors are needed in flows that overtop the barrel and exceed speeds of about 0.8 m/s. Snorkeling or SCUBA equipment is required when sampling depths exceed about 1.3 m.

7.2 Collecting Long Cores in Shallow Water:

7.2.1 Collecting long cores requires a well-drilling rig modified for soil-sampling applications. Because the rig must be towed or winched to the sampling site, water depths must be shallower than about 0.5 m and the underlying sediment must be strong enough to support the rig's weight.

7.2.2 Hvorslev's sampler (Fig. 13), or Butter's sampler (Fig.

14), have been found satisfactory for this purpose. Trained operators are needed because these samplers are easily damaged by improper use, incorrect assembly, or poor lubrication.

7.2.3 Cores are collected in segments that, depending on soil firmness, range in length from about 0.4 to about 0.6 m.

7.2.4 To begin a coring operation, set the piston flush with the barrel's cutting edge and then set the bottom of the barrel against the sediment. While holding the sampler in this position, lower a section of piston rod (1.3 cm pipe fitted with flush couplings) through the top end of the drill rod then screw the piston rod into the coupling atop the sampler. When the threads are fully engaged, unlock the piston by rotating the rod through the proper angle (five clockwise revolutions for Hvorslev's sampler and 1/4-clockwise revolution for Butter's sampler). Clamp the piston rod to the drill-rig frame or, to a stationary frame independent of the drill rig. The first section of core is cut by pushing down on the drill rod. This drive should be made in one continuous stroke and the barrel should not be allowed to rotate as it moves down. Avoid overdriving. Stop the motion when the barrel has advanced to within a few centimetres of its rated maximum travel. Remove the piston rod, break the core from the parent material by turning the drill rod a few degrees, and then carefully lift the sampler along with the core back to the surface. A mechanism inside the sampler automatically locks the piston to the barrel and thereby supports the core during the lifting operation. As an added precaution against losing the core, slide a plate (or hand) under the barrel before the cutting edge clears the water.

7.2.5 After extruding the core, enlarge and then clean the sampling hole (see Fig. 15) by augering or wash boring. If the sampling walls are too weak to stand, they must be cased. When the hole is ready, collect another core section by repeating the procedure described in 7.2.4. Repeat the cycle of coring, enlarging, cleaning, and casing until the desired sampling depth has been reached.

7.2.6 The Osterberg sample shown in Fig. 16 has been found satisfactory for the purpose of sampling without using a piston rod. Instead of using a piston rod, the sampler's top

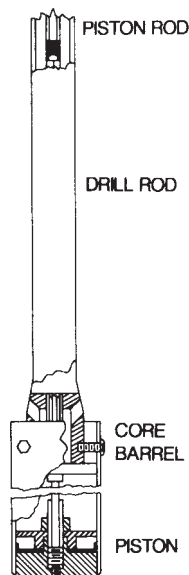

NOTE—The center section houses complex mechanical linkages.
FIG. 13 Hvorslev's Thin-Wall Fixed-Piston Sampler (23)

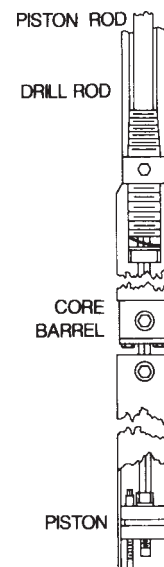

FIG. 14 Butter's Thin-Wall Fixed-Piston Sampler (23)

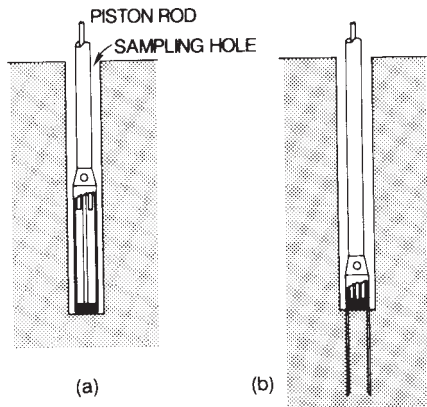
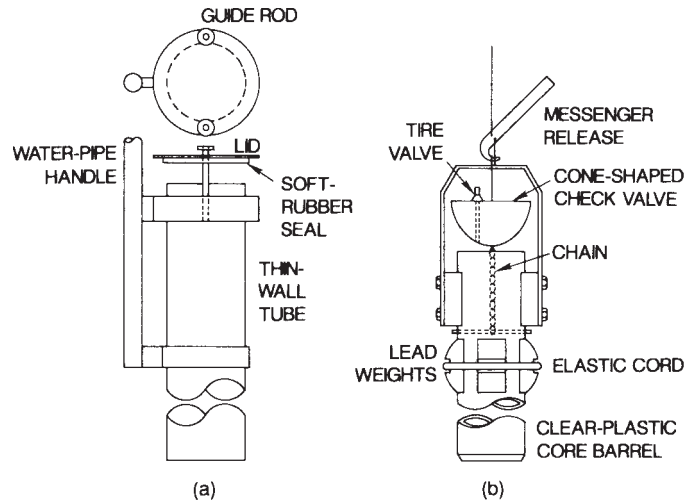

FIG. 15 Sampling with Hvorslev's or Butter's Fixed-Piston Sampler (23)



NOTE 1—(a) Modified Van-Stratten sampler. (4) (b) Milbrink's bottom sampler. (6)

NOTE 2—Fig. 17(a) has been reprinted from Bouma, A. H., *Methods for the Study of Sedimentary Structures*, 1969, with the permission of John Wiley and Sons, Inc., New York, NY.

FIG. 17 Core Samplers for Use in Depths from 1 to 10 m

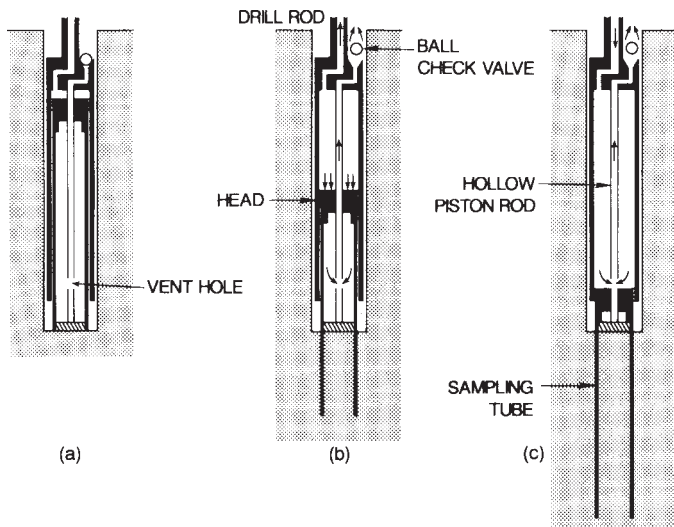

NOTE—(a) Retracted sampling tube, (b) partially extended sampling tube, and (c) fully extended sampling tube. (Arrows indicate water flow.)

FIG. 16 Sampling with Osterberg's Thin-Wall Fixed-Piston Sampler (23)

section is held with a drill rod while the core barrel is driven downward with water pressure. Overdrives are prevented because the head automatically vents the water pressure at the proper point in the stroke.

7.3 Collecting Short Cores in Water Depths Ranging From About 0.5 m to About 10 m:

7.3.1 A boat is required to sample in water deeper than about 0.5 m. However, a boat's propeller creates backwash currents that can easily disturb loose, fluffy deposits (24). This backwash problem is most severe in depths of 1 to 6 m. When working in this critical-depth range, approach sampling points slowly and apply engine power gradually.

7.3.2 Operators sometimes prefer a sampler that can be pushed down with a stiff rod. The modified Van Stratten sampler (Fig. 17(a)), a simple, lightweight sampler that can be coupled to a water-pipe handle up to 6 m long has been found satisfactory for this purpose. During penetration, the lid remains open. During retrieval, the lid slides down the guide rods and seals against the core-barrel's rim. Schneider (25) gives

plans for a lightweight piston sampler that penetrates 1.2 m into loose sediments commonly found on lake and pond bottoms.

7.3.3 Milbrink's sampler (see Fig. 17(b)) can be operated with a cable or wire. The core barrel is a 7- by 30-cm plastic tube sharpened at one end and banded with lead weights. The check valve, which is a cone-shaped rubber stopper, has a vent hole capped with an automobile tire valve. The procedure for collecting samples is simple. Slowly lower the sampler to a point about 1 m above the bed, then allow the sampler to fall the remaining distance to gain momentum. After the core has been cut, close the check valve by sliding a messenger weight down the suspension cable to active the release mechanism, and seat the check valve. The sampler does not have a core catcher so the entire apparatus must be lifted slowly and carefully to avoid losing the core. Seal the barrel's bottom end with a flat plate before the sampler is lifted above the water. When the sampler is safely on board, open the tire valve to break the vacuum and facilitate removing the check valve and core.

7.3.4 If a core must be longer than about 0.5 m, a simple-drive apparatus will sometimes suffice. Fig. 18 shows a lightweight sampling platform and pulley arrangement that can be used with a Swedish-foil sampler or basic piston samplers. The line on the top hook holds the piston stationary while the line on the bottom hook pulls the core barrel downward. When the drive is complete, the lines are restrung for lifting. The top-hook line is clamped to the core barrel and the bottom-hook line is removed from the bottom pulley and tied to the core barrel.

7.3.5 Fuller and Meisburger (27) give plans for an air-driven vibratory corer for use in lakes and estuaries. The vibrator assembly is commercially available and the remaining parts are easy to build. Core lengths range from about 1 m in sand to about 2 m in silt.

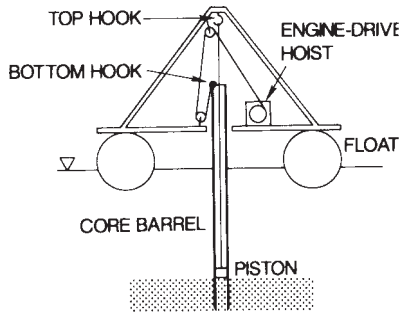

NOTE—Cables strung for coring phase.

FIG. 18 Sampling Platform for Swedish Foil and Piston-Type Samplers (26)

7.3.6 Coring the beds of estuaries and large rivers requires a sampler light enough to deploy from a tugboat-size craft yet heavy enough to stand upright and resist the tipping forces created by flowing water. The Prych-Hubbell sampler (see Fig. 19) has been found satisfactory for the purpose of withstanding flow velocities up to 1.5 m/s and coring sandy bottoms to a depth of about 1.8 m. Fig. 19(a) through (d) shows cable configurations during each of the four operational phases. During the lowering phase, spring-loaded locking pins (Fig. 19(e)) hold the barrel in a retracted position. These pins release when the sampler strikes bottom and the suspension cable momentarily slackens. During the coring phase, (Fig. 19(b)) three forces, tension in the side cables, vibration, and weight, push the barrel downward. Coring continues until an electrical switch (see Fig. 11) hits the streamlined weight and discon-

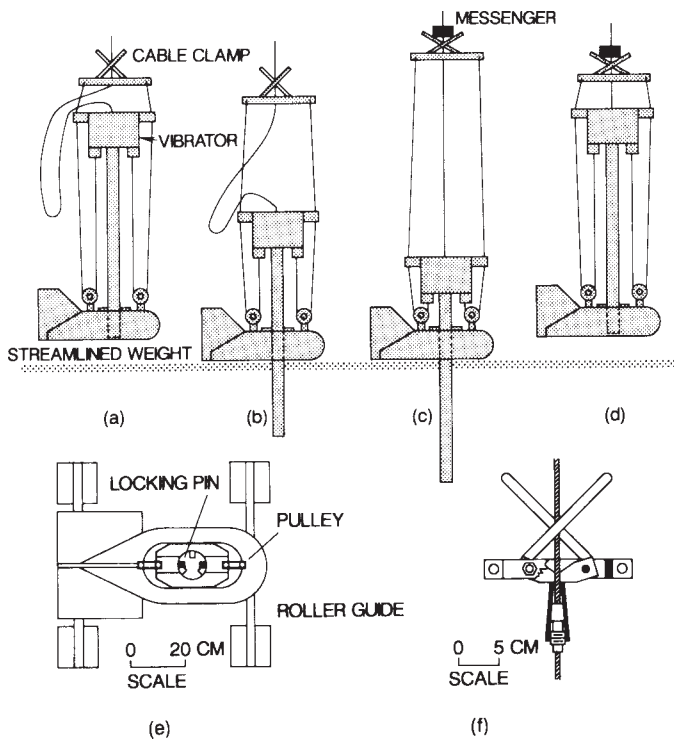

NOTE—(a) lowering, (b) coring, (c) extracting, (d) ascending, (e) top view of streamlined weight, and (f) detail of cable clamp.

FIG. 19 Prych-Hubbell Core Sampler (28)

nects power to the vibrator. The “extraction” phase (Fig. 19(c)) begins when a messenger weight releases the cable clamp (Fig. 19(f)) holding the center cable. The barrel is then pulled upward by reeling in the suspension cable. The “ascending” phase (Fig. 19(d)) begins when the cutting edge passes a spring-loaded plate (not shown) that rotates under the barrel to support the core.

7.4 Collecting Long Cores in Water Depths Ranging From About 0.5 m to About 10 m:

7.4.1 The Butter sampler shown in Fig. 14 or the Osterberg sampler shown in Fig. 16, have been found satisfactory for the purpose of collecting cores longer than about 3 m. The drill rig for the sampler is loaded onto a barge, towed to the sampling site, and then anchored in position. Basically, the sampling techniques are identical to those described in 7.2.

7.4.2 Long cores of soft sediment can be collected with large, momentum-driven piston samplers similar to the one in Fig. 20. These samplers can be used only if water depths exceed about 8 m. The samplers are several metres long and must fall about 3 m before striking the bed.

7.5 Collecting Short Cores in Depths Exceeding 10 m:

7.5.1 Box corers, sometimes referred to as spade corers, can be used to collect undisturbed samples of soft sediments (29). Fig. 21 shows a USNEL (U.S. Navy Electronics Laboratory) box corer that penetrates 20 to 30 cm. Since the barrel is completely open during descent, particles at the sediment-water interface are not disturbed as the sampler approaches. During penetration (Fig. 21(a)), the stand rests on the sediment as the rectangular-shaped core barrel slides down through the gimbals. The sampler’s north-south orientation registers on the compass which locks when the compass wire trips. The closing stage (Fig. 21(b)) begins when the suspension-cable slackens and releases the hook. As the operator reels the cable, the spade rotates downward toward the barrel’s cutting edge. The ascent stage (Fig. 21(c)) begins when the spade reaches the barrel and

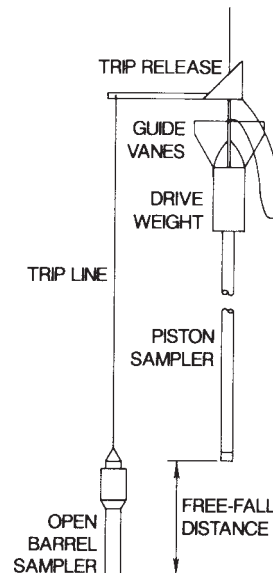
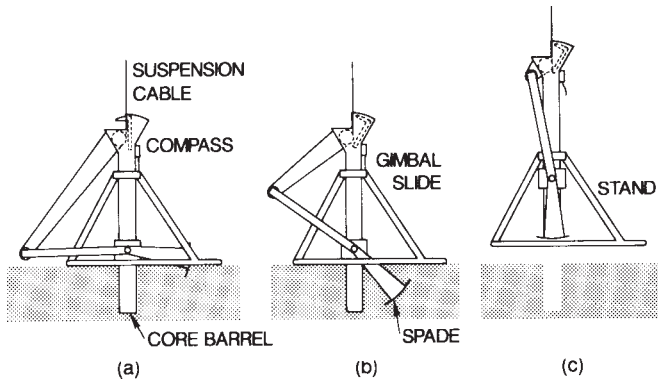

FIG. 20 A Deep-Water Piston Sampler Coupled to an Open-Barrel Sampler



NOTE—(a) The core barrel cuts downward. (b) Cable tension rotates the spade toward the cutting edge. (c) The core sample rests on the spade during pull out and ascent.

FIG. 21 USNEL Spade Corer (34)

closes under the core. Box corers collect high-quality samples (30), but the equipment is bulky and heavy (most box corers weigh about 400 kg).

7.5.2 The SCCWRP corer (Fig. 22) is an open-barrel sampler that weighs 130 kg and penetrates about 1 m into soft sediments. The sampler is lowered slowly. But when the trip-weight contacts the bed, the sampler drops free and quickly gains speed. When the barrel stops its downward penetration, the bail trips a latch and the bungee cord closes the lid. The lid, which serves as a check valve, works in conjunction with the core catcher to hold the core in the barrel during retrieval.

7.5.3 Free corers (Fig. 9) are designed to collect cores about 1 m long (3). The samplers are costly to operate and their impact speed is difficult to control; however, these disadvantages are offset by compactness and ease of deployment (32). Commercially-made free corers weigh about 90 kg and are rated for depths of 9000 m.

7.6 Collecting Long Cores in Depths Exceeding 10 m:

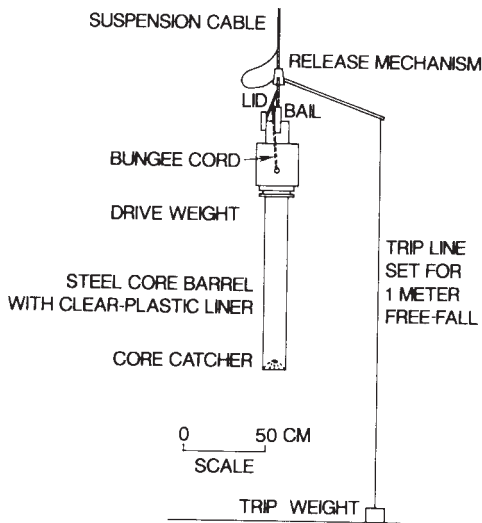

NOTE—The bungee cord closes the check valve when the bail rotates to the right.

FIG. 22 SCCWRP Corer for Soft Sediments (7)

7.6.1 Momentum-driven piston-type samplers are frequently used to collect cores longer than about 1 m. Since momentum and mass are closely related, all long-core samplers are heavy. For example, one commercially made sampler with a barrel 15 m long weighs about 1000 kg. Since momentum is also related to speed, long corers are streamlined so that they accelerate rapidly and reach high impact speeds. To some degree, a sampler's impact speed can be increased by lengthening its trip line (Fig. 21). However, this practice has limitations imposed by acceleration and rotation. When a sampler is released, it starts to gain speed but the acceleration lasts for only a few seconds. Thereafter, the sampler plunges downward at a steady rate. Most heavy samplers achieve a stable speed in falling about 3 m. Dropping a sampler from heights greater than 3 m not only fails to increase penetration but also accentuates problems of rotation. As a sampler falls, it rotates out of plumb. Penetration depths become shallow, flow-in distortion becomes severe, and the danger of breaking or bending the barrel increases. Optimum free-fall distances vary among samplers. Therefore, manufacturers' recommendations should be carefully reviewed before setting trip-line lengths.

7.6.2 Piston immobilizers should be used if depths of penetration vary unpredictably from one sampling site to another. Penetration depth can usually be gaged by the length of mud smears on the outside walls of the sampler's barrel.

7.6.3 The top portion of most piston-sampler cores fail to show true interface-zone conditions. This deficiency can sometimes be eliminated by using an open-barrel corer (or a box corer) for the piston sampler's trip weight (Fig. 20). With this arrangement, two core samples are obtained in each pass. Analysis of the interface zone should be performed on the open-barrel core and analysis of sub-surface zones should be performed on the piston-sampler core.

7.6.4 Vibratory corers overcome stability and surface-disturbance problems inherent to piston samplers. Long vibratory corers driven by compressed air cut to depths of about 12 m in sandy deposits (33).

8. Field Records

8.1 Preparing accurate and complete records is an important part of every sampling operation. Attach a log sheet to each core giving:

- 8.1.1 The core's identification number,
- 8.1.2 The operator's name or initials,
- 8.1.3 The purpose for collecting the core,
- 8.1.4 The type and serial number of the sampler used,
- 8.1.5 The exact location of the sampling site, and
- 8.1.6 Descriptive information on the sampling procedure.

8.2 Also record all information bearing on the core's overall quality (representativeness). For example, if the bottom section of the core slipped through the catcher, or if the barrel failed to make full penetration, these facts should be noted. If a core of substandard quality must be analyzed, an accurate record is helpful in interpreting laboratory data.

8.3 Inspect and measure each core before removing it from the barrel. Determine the length of the core (designated "A" in Fig. 1) by first drawing a line on the outside of the barrel opposite the top of the core and then measuring from the line

to the cutting edge. In an open-barrel sampler, locate the top of the core by opening the check valve and inserting a ruler through the opening. In a piston sampler, the top of the core touches the piston's lower face which can be located after measuring the exposed length of piston wire. In a cryogenic sampler, the entire core is fully exposed so its length can be measured directly.

8.4 Determine the barrel's penetration (designated "B" in Fig. 1) by marking the interface line on the barrel and then measuring from this line down to the cutting edge. The method for locating the interface depends on the water depth. In shallow water, mark the interface on the barrel before retrieving the sampler. In deep water, the interface usually lies at the uppermost extremity of mud smears on the barrel's outer surface. However, mud smears are sometimes deceptive. If the sampler tips over, smears may appear along the full length of the barrel. Smears that girdle only a fraction of the barrel's perimeter are poor penetration-depth indicators.

8.5 Check the lower portion of each core for missing sediment. If the bottom of a core lies above the catcher, measure and record the length of the intervening gap.

8.6 It is helpful to record information on printed forms that include headings for laboratory test results in addition to the field observations. Fig. 2–23 of the Earth Manual (23) shows a form for punch-core samples intended for use in moisture content and density tests.

9. Extruding Cores

9.1 Some samplers have no liners so cores must be extruded (pushed from the barrels) before the samplers can be reused. Start the extrusion process immediately after finishing the field records. Speed is essential because mechanical bonds between a core and a core-barrel strengthen quickly. Delays make the extrusion process more difficult.

9.2 Two special tools are required; a stiff rod with a piston at one end and a T handle at the other and a round-bottom trough with a smooth inner surface. The diameter of the piston and trough must match the inside diameter of the core barrel. The rod and trough must both be longer than the barrel. However, beyond this, lengths are not critical.

9.3 To begin the extrusion process, lay the sampler on a level surface, then clear the ends of the barrel by removing the core catcher and check valve. On some samplers, the barrel must be unscrewed from suspension hardware and driving weights. Insert the piston on the T-handle rod inside the cutting end of the barrel. It is important to work from the cutting end (4) because sediments in this region are tightly compacted by the core cutting operation. By comparison, sediments at the top end of the barrel are only loosely compacted and therefore are easily compressed by forces on the piston. When the piston is in place, align the trough with the top end of the barrel.

9.4 Equipment for pushing a piston through the barrel depends on the sampler's size. On small samplers, hand pressure is sufficient to dislodge the cores but on large samplers block-and-tackle pullers are required. To use a puller, anchor the T-handle and one end of the puller to a sturdy support and then fasten the other end of the puller to the bottom section of

the barrel. Slowly increase the pressure to break the core free. Then maintain a steady pressure to slide the core into the trough.

10. Slitting Core Liners

10.1 A core encased in a liner can be extruded. However, slitting and removing the liner causes less distortion within the core itself. Power tools and bulky supports are required, so the slitting operation must usually be performed in a laboratory.

10.2 Freeze loosely packed cores to prevent slumping during and after the slitting process.

10.3 Fig. 23 shows a clamp for holding the liner during the slitting operation. Fasten two angle irons to a steel plate which, in turn, is fastened to two 102-mm channels. The rear angle iron is welded but the front angle iron is bolted through slotted holes that permit adjustment.

10.4 The liner, which rests on the wooden spacer, is clamped with its top surface about 1 cm below the angle iron edges.

10.5 Cuts are made with a 6-mm carbide-tipped bit driven by a heavy-duty router. Set the router base across the irons then, while holding the router fence against one of the irons, center the bit over the liner. Lower the bit to cut about halfway through the liner wall. Then tighten all adjustments and make an end-to-end cutting pass. Return to the starting point, lower the bit to cut about 1 mm above the core, and then make a second cutting pass.

10.6 After one side has been cut, rotate the liner 180° and repeat the procedure in 10.5.

10.7 Carefully move the liner and core to a work table. Break away all uncut liner fragments from the grooves then lift the top half of the liner to expose the core.

11. Slitting Cores

11.1 An exposed core can be slit (cut lengthwise) to reveal internal grain structures. The slitting process works best if the core is resting in its extrusion trough or in the bottom half of its core liner.

11.2 A core containing a high percentage of sand can be slit with a slender wire strung on a cheese cutter or copingsaw frame. Guide the wire along the edges of the liner (or trough) and, at the same time, pull the wire through the sediment. Insert

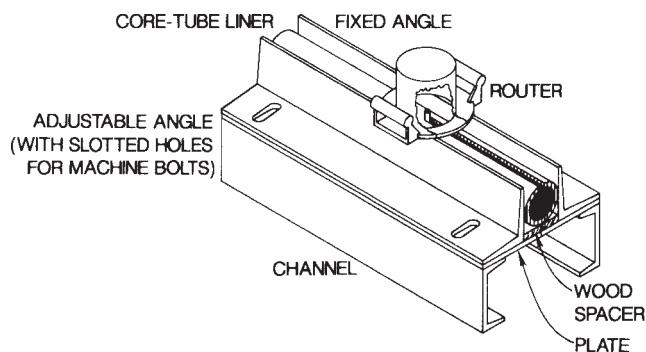

NOTE—Fixed angle, plate, and two channels are welded as a unit.

FIG. 23 Core-Liner Slitting Apparatus (34)

thin sheet-metal strips behind the wire to prevent the freshly cut surfaces from adhering to one another.

11.3 A core that has dried and hardened can be cut with a hacksaw blade driven by hand pressure. A gentle sawing action usually eases the cutting process.

11.4 A core containing a high percentage of clay can be slit with a thin wire, a sharp knife, or an electro-osmotic cutter.

11.5 An electro-osmotic cutter (see Fig. 24), is an ordinary knife (or wire) charged with direct current. The cutter cleanly severs sediments (4). (**Warning**—To minimize harm from shocks delivered by electro-osmotic cutters, operators should wear insulated gloves and boots.)

11.6 To make the setup, imbed the probe in the core. The probe, which can be a nail or awl, serves as a ground return for the electric current. Polarity is important. The probe must be connected to the positive lead and the knife to the negative lead. To start a cut, moisten the knife, press it to the core, and then adjust the transformer for the best cutting action. For most cores, ammeter currents should be 1 to 4 A. Rewet the knife frequently as cutting proceeds. To prevent blowing fuses, avoid touching the probe with the knife.

11.7 After the core has been slit, separate the halves and clean the cut surfaces. Particles dislodged by the cutter can be removed with tweezers or a soft brush. Surface smears can be removed with a brush or scraped away with a razor blade.

11.8 Inspect the core, particularly its bottom end, for sections disturbed by flow-in. Centers of these sections are marked by rectangular grain patterns as shown in Fig. 8. Ends of flow-in sections fall where the strata lines shift abruptly from horizontal alignment to vertical alignment (13). All disturbed sections should be clearly marked because they do not represent bed-deposit structures.

12. Sectioning Cores

12.1 Sectioning (cutting across a core's axis) is the first step in performing certain types of laboratory analysis. Perform the sectioning with the core inside its liner. Because the core will be cut into several pieces, it is important to label several points along the core. Lay the liner on a table, mark the desired cut points, then start at the bottom of the core and number the sections in sequence. Also, label the top and bottom of each section.

12.2 To prevent slumping, freeze points along the core before the cuts are made. Set the lower halves of dry-ice boxes (Fig. 25) under the liner at all cut-point marks, then set the upper halves of the boxes in place. Fill all boxes with dry ice, then cover them to speed the freezing process. Allow only enough time to freeze sediment near each cut point (one 4-cm

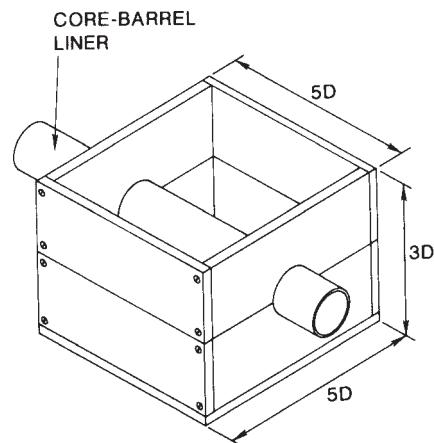

NOTE—Dimension "D" matches outside diameter of core-barrel liner.

FIG. 25 Dry-Ice Freezer Box (35)

core takes about 25 min). At the proper time, remove the boxes and cut through the liner and core with an ordinary carpenter saw. Cut rapidly to avoid premature thawing.

12.3 After completing each cut, support the exposed sediment by taping a disk of polystyrene over the section ends.

12.4 Refer to 11.8 regarding contamination.

13. Sampling Through Liner Walls

13.1 Small specimens of a core may be collected after cutting an opening in the core-liner wall. Use an electric drill and carpenter's hole saw to cut a circular disk from the liner. Exert only gentle pressures to prevent the saw from breaking through the liner and plunging into the core. Remove the specimen, then replace the disk, and seal it in place with adhesive-backed cloth tape (commonly known as duct tape).

14. Preserving and Displaying Cores

14.1 Cores to be preserved in their natural state must be hermetically sealed to prevent evaporation and condensation.

14.2 An extruded core or slit core should be sealed, along with its extrusion trough or the bottom half of its liner. Wrap the core and its liner with several layers of aluminum foil, and then seal all edges with molten wax. An alternative procedure is to slide the core and its liner into heat-shrinkable tubing, and then shrink the tubing by fanning it with warm air from an electric hair dryer. Ends of a core are particularly vulnerable; they should be sealed with several layers of wax and foil.

14.3 Sealed cores should be stored in a temperature-controlled chamber to retard the growth of bacteria. Set the temperature at approximately 2°C.

14.4 Polishing core surface is effective for highlighting grain-structure details. A core scheduled for polishing must first be impregnated—pores between sediment grains are filled with liquid resin that hardens and bonds all particles together. The impregnation process (4) involves several operations. First, section the core into pieces approximately 0.15 m long. Place the pieces in an aluminum pan, and then set the pan and its contents in an oven at 93°C. After a few hours, raise the temperature to about 170°C. Maintain this temperature until all traces of moisture have disappeared, and let the sections cool to

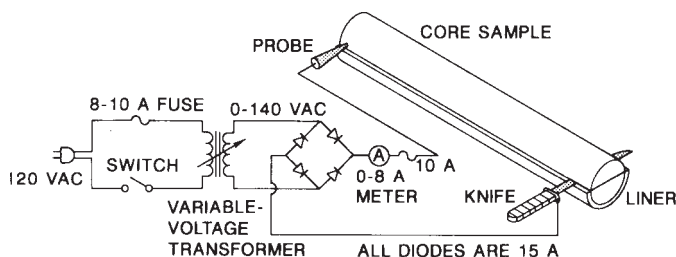

FIG. 24 Schematic of Electro-Osmotic Cutter (4)

room temperature. Next, fill the pan with a clear casting resin, and place the pan and its contents in a vacuum desiccator. Release the vacuum after 30 min, and place the pan and its contents in a dry-nitrogen pressure chamber. Hold the pressure at 1 atm for about 30 min, and slowly release the pressure. After the resin has completely cured and hardened, saw and polish the sections. Bouma (4) gives several other impregnation techniques.

14.5 Making a lacquer peel (4) is another way to preserve and display grain-structure details. This technique works best on flat surfaces made with a slitting knife or osmotic cutter. Carefully scrape the surface to remove smears left by the knife, and allow the surface to dry completely. Apply one coat of lacquer with a sprayer, and after several minutes, apply one or

two more coats with a brush. When the last coat is firm but still tacky, cover it with a layer of cheesecloth, and paint the cloth with another layer of lacquer. After the surface and coatings have hardened, lift and peel away the cloth-lacquer laminate to expose the thin layer of sediment adhering to the first coat. Protect this sediment by spraying it with a thin coat of lacquer, cut away the excess cloth, and trim the edges. The finished lacquer peel can be mounted on a stiff board for display.

15. Keywords

15.1 core distortion; core samplers; freeze core samplers; grab samplers; piston samplers; sampling errors; sediment sampling; surface samplers; vibratory samplers

REFERENCES

- (1) Weaver, P. P. E., and Schultheiss, P. J., "Detection of Repenetration and Sediment Disturbance in Open-Barrel Gravity Cores," *Journal of Sedimentary Petrology*, Vol 53, No. 2, June 1983, pp. 649–654.
- (2) Schultheiss, P. J., "Geotechnical Properties of Deep Sea Sediments: A Critical Review of Measurement Techniques," Institute of Oceanographic Sciences, Wormley, U. K., Report No. 134, 1982.
- (3) Sachs, P. L., and Raymond, S. O., "A New Unattached Sediment Sampler," *Journal of Marine Research*, Vol 23, 1965, pp. 44–53.
- (4) Bouma, A. H., *Methods for the Study of Sedimentary Structures*, Wiley-Interscience, New York, NY, 1969, pp. 301–378.
- (5) Carrigan, P. H., Jr., "Inventory of Radionuclides in Bottom Sediment of the Clinch River Eastern Tennessee," U.S. Geological Survey Professional Paper 433-I, U.S. Government Printing Office, Washington, DC, 1969.
- (6) Milbrink, G., "A Simplified Tube Bottom Sampler," *Oikos:Acta-Oecologica-Scandinavica*. No. 22, 1971, pp. 260–263.
- (7) Bascom, W., Mardesich, J., and Stubbs, H., "An Improved Corer for Soft Sediments," Coastal Water Research Project, Biennial Report for 1981–1982, Willard Bascom, ed., Southern California Coastal Water Research Project, Long Beach, CA, 1982, pp. 267–271.
- (8) Peters, R. D., Timmins, N. T., Calvert, S. E., and Morris, R. J., "The IOS Box Corer: Its Design, Development, Operation and Sampling," Institute of Oceanographic Sciences, Wormley, U. K., Report No. 106, 1980.
- (9) Kermabon, A., Blavier, P., Cortis, V., and Delauze, H., "The "Sphincter" Corer: A Wide-Diameter Corer with Watertight Core-Catcher," *Marine Geology*, Vol 4, 1966, pp. 149–162.
- (10) Kallstenius, T., "Mechanical Disturbances in Clay Samples Taken with Piston Samplers," *Royal Swedish Geotechnical Institute Proceedings*, No. 16, Ivar Haeggstroms Baktryckeri AB, Stockholm, 1958.
- (11) Hvorslev, M. J., *Subsurface Exploration and Sampling of Soils for Civil Engineering Purposes*, U.S. Army, Corps of Engineers, Waterways Experiment Station, Vicksburg, MI, 1949.
- (12) Silva, A. J., and Hollister, C. D., "Geotechnical Properties of Ocean Sediments Recovered with Giant Piston Corer," *Journal of Geophysical Research*, Vol 78, No. 18, June 20, 1973, pp. 3597–3616.
- (13) Bouma, A. H., and Boerma, J. A. K., "Vertical Disturbances in Piston Cores," *Marine Geology*, Vol 6, 1968, pp. 231–241.
- (14) Burns, R. E., "A Note on Some Possible Misinformation From Cores Obtained by Piston-Type Coring Devices," *Journal of Sedimentary Petrology*, Vol 33, 1963, pp. 950–952.
- (15) Kermabon, A., and Cortis, V., "A New "Sphincter" Corer with a Recoilless Piston," *Marine Geology*, Vol 7, 1969, 147–159.
- (16) Hopkins, T. L., "A Survey of Marine Bottom Samplers," *Progress in Oceanography*, Vol 2, Pergamon Press, Inc., Elmsford, NY, 1964, pp. 215–256.
- (17) Brakensiek, D. L., Osborn, H. B., and Rawls, W. J., "Field Manual for Research in Agricultural Hydrology," Agricultural Handbook No. 224, U.S. Dept. of Agriculture, Science and Education Administration, 1979.
- (18) Hubbell, D. W., and Glenn, J. L., "Distribution of Radionuclides in Bottom Sediments of the Columbia River Estuary," U.S. Geological Survey Professional Paper 433-L, U.S. Government Printing Office, Washington, DC, 1973, pp. L6–L7.
- (19) Prych, E. A., Hubbell, D. W., and Glenn, J. L., "New Estuarine Measurement Equipment and Techniques," *Journal of the Waterways and Harbors Division, Proceedings of the American Society of Civil Engineers*, Vol 93, No. WW 2, May, 1967, pp. 41–58.
- (20) Everest, F. H., McLemore, C. E., and Ward, J. F., "An Improved Tri-Tube Cryogenic Gravel Sampler," U.S. Department of Agriculture, Forest Service, 809 NE 6th Ave., Portland, OR, PNW-350, March 1980.
- (21) Inter-Agency Committee on Water Resources, Subcommittee on Sedimentation, "Determination of Fluvial Sediment Discharge," *A Study of Methods Used in Measurement and Analysis of Sediment Loads in Streams*, Federal Inter-Agency Sedimentation Project, Minneapolis, MN, Report No. 14, 1963.
- (22) Yuzyk, T. R., "Bed Material Sampling in Gravel-Bed Streams," *Environment Canada, IWS-HQ-WRB-SS-86-8*, 1986.
- (23) Earth Manual, A Water Resources Technical Publication, 2nd Ed., U.S. Dept. of Interior, Water and Power Resources Services, U.S. Government Printing Office, Washington, DC, 1974, pp. 361–383.
- (24) Sly, P. G., "Bottom Sediment Sampling," Center for Great Lakes Research, Canada Centre for Inland Waters, Burlington, Ontario, 1969, pp. 883–898.
- (25) Schneider, R. F., "A Coring Device for Unconsolidated Lake Sediments," Water Resources Research, U.S. Department of Interior, Federal Water Pollution Control Administration, Southeast Water Laboratory, Athens, GA, Vol 5, No. 2, 1969, pp. 524–526.
- (26) Pickering, R. J., "River-Bottom Sediment Sampling With a Swedish Foil Sampler," Selected Techniques of Water-Resources Investigations, 1965, U.S. Geological Survey Water-Supply Paper 1822, U.S. Government Printing Office, Washington, DC, pp. 94–99.
- (27) Fuller, J. A., and Meisburger, E. P., "A Lightweight Pneumatic Coring Device: Design and Field Test," U.S. Army, Corps of Engineers, Coastal Engineering Research Center, Fort Belvoir, VA, Miscellaneous Report No. 82-8, September 1982.
- (28) Prych, E. A., and Hubbell, D. W., "A Sampler for Coring Sediments in Rivers and Estuaries," *Geological Society of America Bulletin*.

- Geological Society of America Publications, Boulder, CO, Vol 77, May 1966, pp. 549–557.
- (29) Hagerty, Royal, *Deep Sea Sediments: Physical and Mechanical Properties*, Marine Series, Plenum Press, New York, NY, 1974, pp. 169–186.
- (30) Bouma, A. H., Marshall, N. F., “A Method for Obtaining and Analyzing Undisturbed Oceanic Sediment Samples,” *Marine Geology*, Vol 2, 1964, pp. 81–99.
- (31) Rosfelder, A. M., and Marshall, N. F., “Obtaining Large, Undisturbed, and Oriented Samples in Deep Water,” *Marine Geotechnique*, A. F. Richards, ed., (*Proceedings*, 1966 International Conference on Marine Geotechnique), University of Illinois Press, Urbana, IL, 1967, pp. 243–263.
- (32) Moore, D. G., “The Free Corer: Sediment Sampling Without Wire and Winch,” *Journal of Sedimentary Petrology*, Vol 31, 1961, pp. 627–630.
- (33) Meisburger, E. P., and Williams, S. J., “Use of Vibratory Coring Samplers for Sediment Surveys,” *Coastal Engineering Technical Aid* No. 81-9, U.S. Army, Coastal Engineering Research Center, Fort Belvoir, VA, No. 81-9, July 1981.
- (34) Meisburger, E. P., Williams, S. J., and Prins, D. A., “An Apparatus for Cutting Core Liners,” *Journal of Sedimentary Petrology*, Vol 50, No. 2, June 1980, pp. 641–645.
- (35) Lara, J. M., and Sanders, J. I., “Investigations of Sediment Properties,” The 1963–64 Lake Mead Survey, U.S. Department of Interior, Bureau of Reclamation, REC-OCE-70-21, Part 4, August 1970, pp. 75–140.
- (36) Hogan, Scott A., Abt, Steven R., and Watson, Chester C., “Development and Testing of a Bed Material Sampling Method for Gravel and Cobble Bed Streams,” Department of Civil Engineering, Colorado State University, Fort Collins, CO, 80523, 1993.

ASTM International takes no position respecting the validity of any patent rights asserted in connection with any item mentioned in this standard. Users of this standard are expressly advised that determination of the validity of any such patent rights, and the risk of infringement of such rights, are entirely their own responsibility.

This standard is subject to revision at any time by the responsible technical committee and must be reviewed every five years and if not revised, either reapproved or withdrawn. Your comments are invited either for revision of this standard or for additional standards and should be addressed to ASTM International Headquarters. Your comments will receive careful consideration at a meeting of the responsible technical committee, which you may attend. If you feel that your comments have not received a fair hearing you should make your views known to the ASTM Committee on Standards, at the address shown below.

This standard is copyrighted by ASTM International, 100 Barr Harbor Drive, PO Box C700, West Conshohocken, PA 19428-2959, United States. Individual reprints (single or multiple copies) of this standard may be obtained by contacting ASTM at the above address or at 610-832-9585 (phone), 610-832-9555 (fax), or service@astm.org (e-mail); or through the ASTM website (www.astm.org).