



Designation: F 2077 – 04³

Test Methods For Intervertebral Body Fusion Devices¹

This standard is issued under the fixed designation F 2077; the number immediately following the designation indicates the year of original adoption or, in the case of revision, the year of last revision. A number in parentheses indicates the year of last reapproval. A superscript epsilon (ϵ) indicates an editorial change since the last revision or reapproval.

1. Scope

1.1 This test method covers the materials and methods for the static and dynamic testing of intervertebral body fusion device assemblies, spinal implants designed to promote arthrodesis at a given spinal motion segment.

1.2 This test method is intended to provide a basis for the mechanical comparison among past, present, and future nonbiologic intervertebral body fusion device assemblies. This test method allows comparison of intervertebral body fusion device assemblies with different intended spinal locations and methods of application to the intradiscal spaces. This test method is intended to enable the user to compare intervertebral body fusion device assemblies mechanically and does not purport to provide performance standards for intervertebral body fusion device assemblies.

1.3 The test method describes static and dynamic tests by specifying load types and specific methods of applying these loads. These tests are designed to allow for the comparative evaluation of intervertebral body fusion device assemblies.

1.4 This test method does not purport to address expulsion testing of intervertebral body fusion device assemblies. However, since expulsion is a potential clinical failure mode, the user should address the implant's resistance to expulsion assemblies (see X1.11).

1.5 Guidelines are established for measuring displacements, determining the yield load or moment, evaluating the stiffness, and strength of the intervertebral body fusion device assemblies.

1.6 Some intervertebral body fusion device assemblies may not be testable in all test configurations.

1.7 The values stated in SI units are to be regarded as the standard with the exception of angular measurements, which may be reported in terms of either degrees or radians.

1.8 *This standard does not purport to address all of the safety concerns, if any, associated with its use. It is the responsibility of the user of this standard to establish appropriate safety and health practices and determine the applicability of regulatory limitations prior to use.*

2. Referenced Documents

2.1 *ASTM Standards:*

¹ This test method is under the jurisdiction of ASTM Committee F04 on Medical and Surgical Materials and Devices and is the direct responsibility of Subcommittee F04.25 on Spinal Devices.

Current edition approved May 10 2004; Apr. 10, 2003. Published June 2004; May 2003. Originally published as F 2077 – 00; in 2000. Last previous edition approved in 2001 as F 2077 - 00¹.

- E 4 Practices for Force Verification of Testing Machines²
- E 6 Terminology Relating to Methods of Mechanical Testing²
- E 1823 Terminology Relating to Fatigue and Fracture Testing²
- F 1582 Terminology Relating to Spinal Implants³

3. Terminology

3.1 For definition of terms refer to Terminology E 6, E 1823, and F 1582.

3.2 *Definitions of Terms Specific to This Standard:*

3.2.1 *coordinate system/axes, n*—Three orthogonal axes are defined by Terminology F 1582. The center of the coordinate system is located at the geometric center of the intervertebral body fusion device assembly. The XY plane is to bisect the sagittal plane angle between superior and inferior lines (surfaces) that are intended to simulate the adjacent vertebral end plates. The positive Z axis is to be directed superiorly. Force components parallel to the XY plane are shear components of loading. The compressive axial force is defined to be the component in the negative Z direction. Torsional load is defined to be the component of moment parallel to the Z axis.

3.2.2 *fatigue life, n*—The number of cycles, *N*, that the intervertebral body fusion device assembly can sustain at a particular load or moment before mechanical or functional failure occurs.

3.2.3 *functional failure, n*—Permanent deformation that renders the intervertebral body fusion device assembly ineffective or unable to resist load and/or maintain attachment adequately.

3.2.4 *ideal insertion location, n*—The implant location with respect to the simulated inferior and superior vertebral bodies (polyacetal or metal blocks) dictated by the type, design, and manufacturer’s surgical installation instructions.

3.2.5 *intended method of application, n*— Intervertebral body fusion device assemblies may contain different types of stabilizing anchors such as threads, spikes, and knurled surfaces. Each type of anchor has an intended method of application or attachment to the spine.

3.2.6 *intended spinal location, n*—The anatomic region of the spine intended for the intervertebral body fusion device assembly. Intervertebral body fusion device assemblies may be designed and developed for specific regions of the spine such as the lumbar, thoracic, and cervical spine. Also, there exists different anatomical potential surgical approaches, which will result in different implant orientation at different levels of the spine.

3.2.7 *intervertebral body fusion device, n*— A structure (biologic or synthetic) that is placed in the disc space between two adjacent vertebral bodies to provide support for eventual arthrodesis of the two adjacent vertebral bodies.

3.2.8 *intradiscal height, n*—The straight-line distance along the Z axis between the unaltered simulated vertebral bodies— minimum height of 4 mm and a maximum height of 18 mm. See Fig. 1.

3.2.9 *load point, n*—The point through which the resultant force on the intervertebral device passes (that is, the geometric center of the superior fixture’s sphere) (Figs. 2-5).

3.2.10 *maximum run out load or moment, n*— The maximum load or moment for a given test that can be applied to an intervertebral body fusion device assembly in which all of the tested constructs have withstood 5 000 000 cycles without functional or mechanical failure.

3.2.11 *mechanical failure, n*—That associated with the onset of a defect in the material (that is, initiation of fatigue crack or surface wear).

3.2.12 *offset angular displacement, n*—(Distance OB—Fig. 6)—Offset on the angular displacement axis equal to 10 % of the intradiscal height, *H*, divided by the outside diameter or height of the implant (maximum dimension of implant in XZ plane if not cylindrical) (for example, for a 10-mm intradiscal height and 16-mm intervertebral body fusion device assembly, distance OB = 10 mm/16 mm (0.10)(180°)/π = 3.6°).

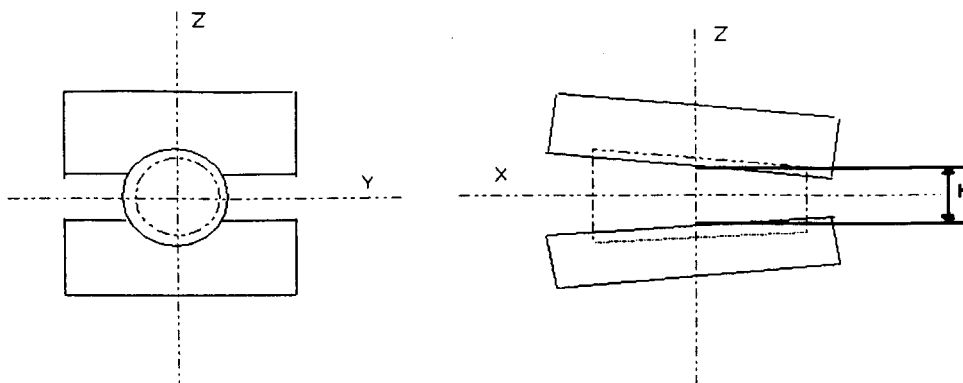

FIG. 1 Intradiscal Height Diagram

² Annual Book of ASTM Standards, Vol 03.01.

³ Annual Book of ASTM Standards, Vol 13.01.

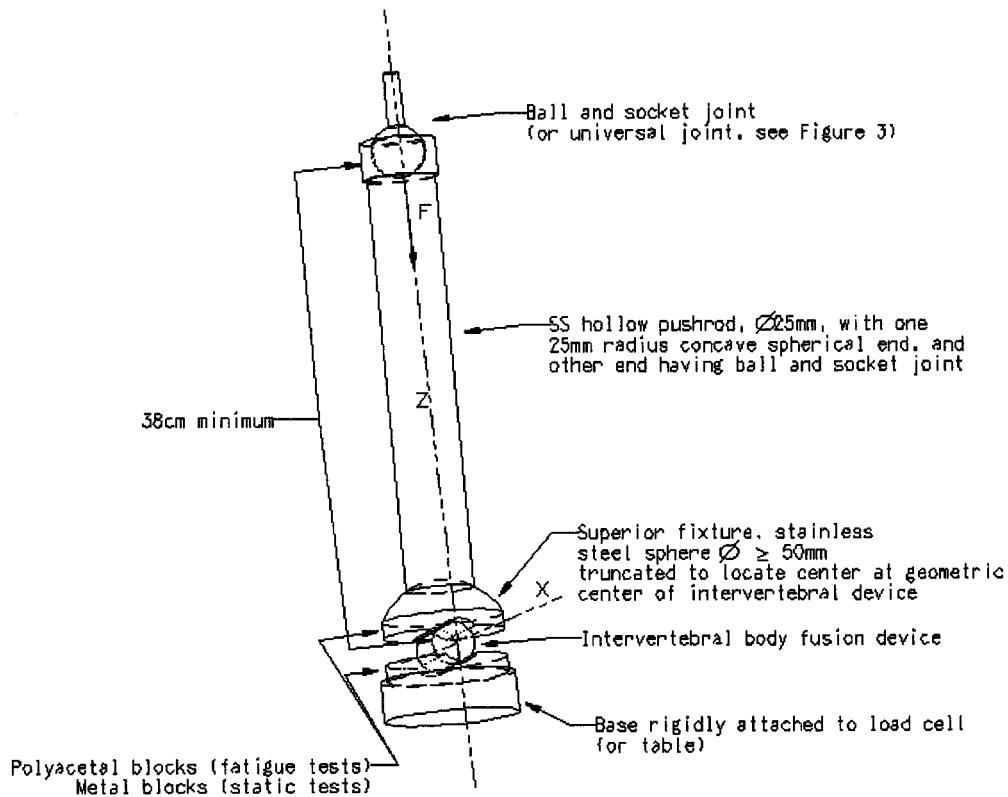

FIG. 2 Compression Testing Configuration

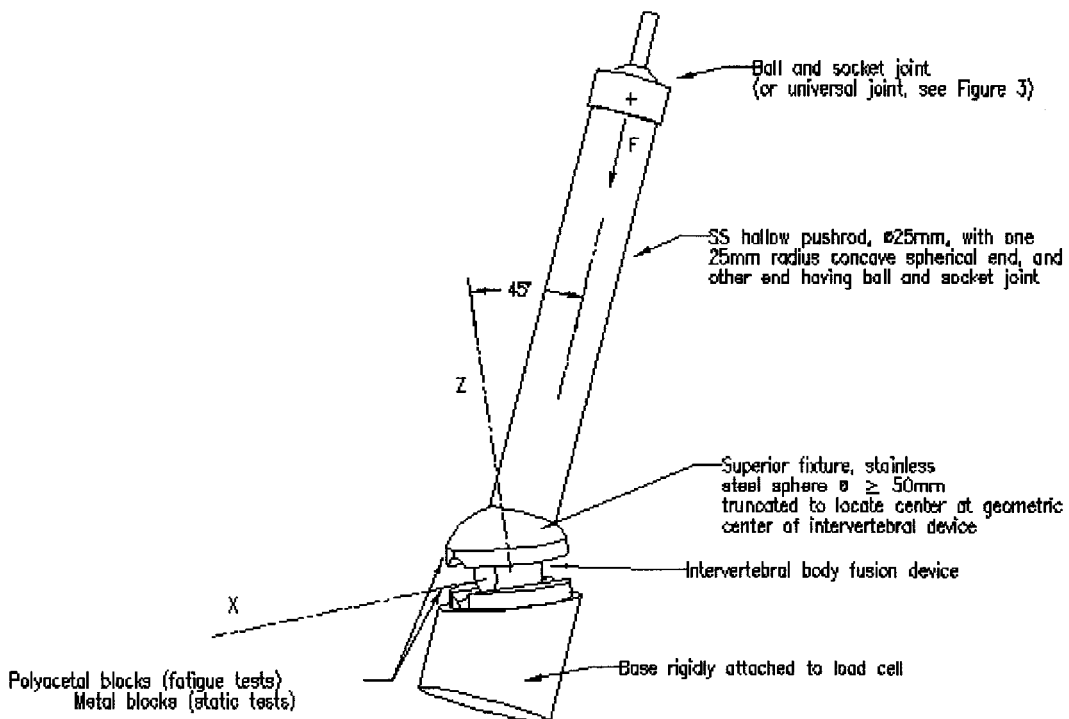

FIG. 3 Compression-Shear Testing Configuration

3.2.13 *offset displacement, n*—(Distance OB—Fig. 6)—Offset on the displacement axis equal to 2 % of the intradiscal height (that is, 0.2 mm for a 10-mm intradiscal height).

3.2.14 *permanent deformation, n*—The remaining displacement (mm or degrees or radians) relative to the initial unloaded condition of the intervertebral body fusion device assembly after the applied load has been removed.

3.2.15 *stiffness (N/mm or N*mm/Degree (Radian)) (The Slope of Line OG—Fig. 6), n*—The slope of the initial linear portion

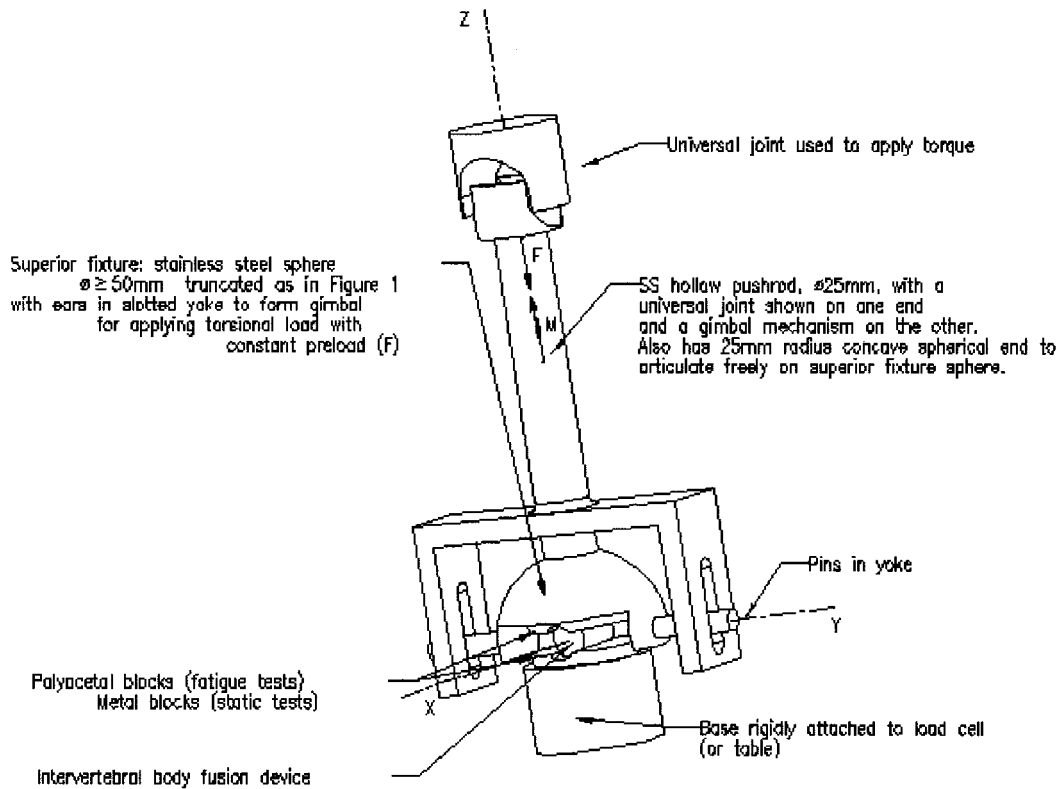

FIG. 4 Torsion Testing Configuration With Pin-Slot Gimbal

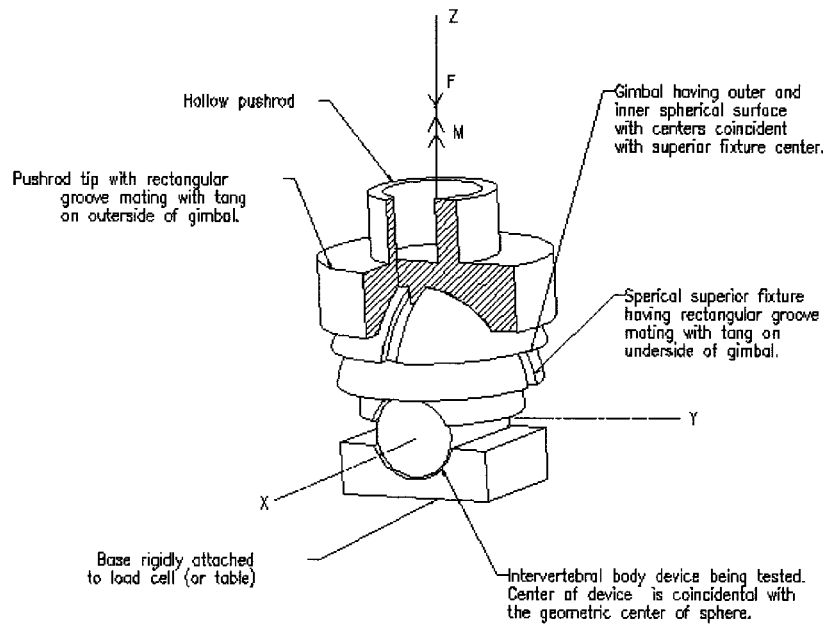

FIG. 5 Spherical Gimbal (Cross Section) for Torsion Testing Apparatus

of the load-displacement curve or the slope of the initial linear portion of the moment—angular displacement curve.

3.2.16 *test block, n*—The component of the test apparatus for mounting the intervertebral body fusion device assembly for the intended test configuration.

3.2.17 *ultimate displacement (millimetres or degrees or radians) (Displacement OF—Fig. 6), n*—The displacement associated with the ultimate load or ultimate moment.

3.2.18 *ultimate load or moment (N or $N\cdot\text{mm}$) (Point E—Fig. 6), n*—The maximum applied load, F , transmitted by the pushrod (assumed equal to force component parallel to and indicated by load cell), or the applied moment about the Z axis that can be applied to an intervertebral body fusion device assembly.

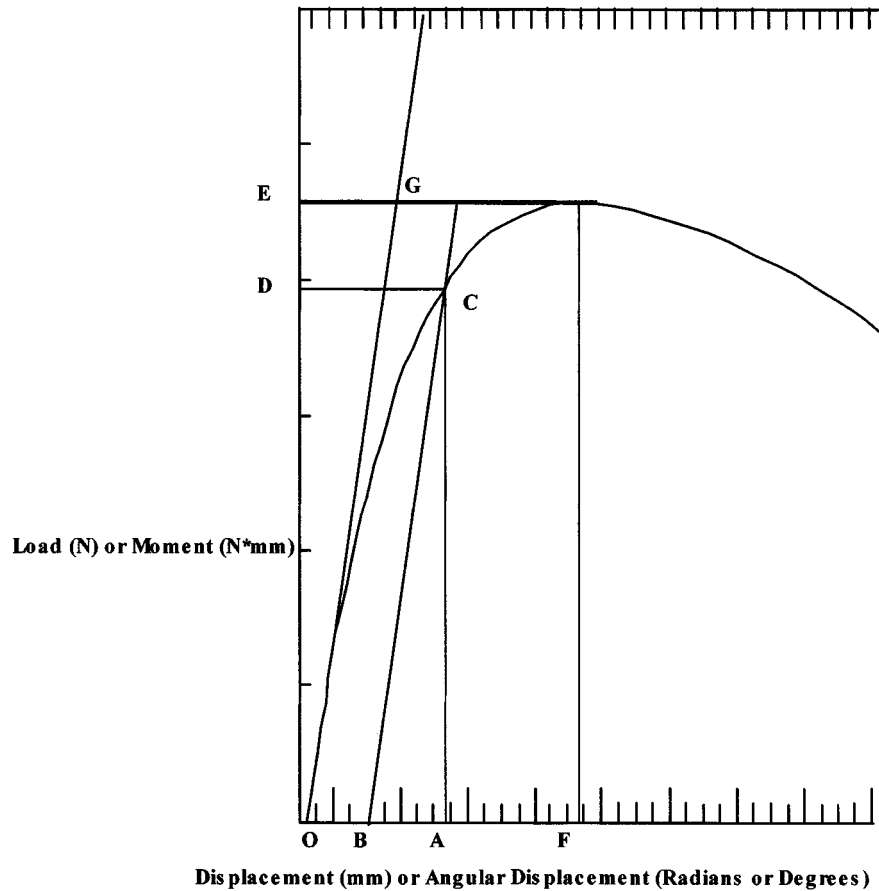

FIG. 6 Typical Load Displacement Curve

3.2.19 *yield displacement* (Distance *OA*—Fig. 6), *n*—The displacement (mm) or angular displacement (deg) when an interbody fusion device assembly has a permanent deformation equal to the offset displacement or the offset angular displacement.

3.2.20 *yield load or moment* (Point *D*—Fig. 6), *n*—The applied load, *F*, transmitted by the pushrod (assumed equal to force component parallel to and indicated by load cell), or the applied moment about the *Z* axis required to produce a permanent deformation equal to the offset displacement or the offset angular displacement.

4. Summary of Test Method

4.1 These test methods are proposed for the mechanical testing of intervertebral body fusion device assemblies specific to the lumbar, thoracic, and cervical spine.

4.2 Fatigue testing of the intervertebral body fusion device assemblies will simulate a motion segment via a gap between two polyacetal test blocks. The polyacetal will eliminate the effects of the variability of bone properties and morphology for the fatigue tests. The minimum ultimate tensile strength of the polyacetal blocks shall be no less than 61 MPa.

4.3 Static testing of the intervertebral body fusion device assemblies will simulate a motion segment via a gap between two stainless steel blocks. The minimum ultimate tensile strength of the blocks shall be no less than 1310 MPa.

4.4 The pushrod shall also be manufactured from stainless steel, which shall also have a minimum ultimate tensile strength no less than 1310 MPa.

4.5 Static and dynamic tests will evaluate the intervertebral body fusion device assembly. The user of this test method must decide which series of tests are applicable to the intervertebral body fusion device assembly in question. The user of this test method may choose to use all or a selection of the tests described in this test method for testing a particular intervertebral body fusion device assembly.

5. Significance and Use

5.1 Intervertebral body fusion device assemblies are generally simple geometric-shaped devices which are often porous or hollow in nature. Their function is to support the anterior column of the spine to facilitate arthrodesis of the motion segment. This test method outlines materials and methods for the characterization and evaluation of the mechanical performance of different intervertebral body fusion device assemblies so that comparisons can be made between different designs.

5.2 This standard test method is designed to quantify the static and dynamic characteristics of different designs of intervertebral body fusion device assemblies. These tests are conducted *in vitro* to allow for analysis and comparison of the mechanical

performance of intervertebral body fusion device assemblies to specific load modalities.

5.3 The loads applied to the intervertebral body fusion assemblies may differ from the complex loading seen *in vivo*, and therefore, the results from these tests may not directly predict *in vivo* performance. The results, however, can be used to compare mechanical performance of different intervertebral body fusion device assemblies.

5.4 Since the environment may affect the dynamic performance of intervertebral body fusion device assemblies, dynamic testing in a saline environment may be considered. Fatigue tests should first be conducted in air (at ambient temperature) for comparison purposes since the environmental effects could be significant. If a simulated *in vivo* environment is desired, the investigator should consider testing in a saline environmental bath at 37°C (for example, 0.9-g NaCl per 100-mL water) at a rate of 1 Hz or less. A simulated body fluid, a saline drip or mist, distilled water, or other type of lubrication at 37°C could also be used with adequate justification.

5.5 If the devices are known to be temperature and environment dependent, testing should be conducted in physiologic solution as described in 5.4. Devices that require physiologic solution for testing should be tested in the same type solution for comparison purposes.

5.6 The location within the simulated vertebral bodies and position of the intervertebral body fusion device assembly with respect to the loading axis will be dependent upon the design, the manufacturer's recommendation, or the surgeon's preferred method for implant placement.

5.7 It is well known that the failure of materials is dependent upon stress, test frequency, surface treatments, and environmental factors. Therefore, when determining the effect of changing one of these parameters (for example, frequency, material, or environment), all others must be kept constant to facilitate interpretation of the results.

6. Apparatus

6.1 Test machines will conform to the requirements of Practices E 4.

6.2 The intradiscal height, H , shall be determined from vertebral body and disc morphometric data at the intended level of application. Suggested heights are as follows: 10 mm for the lumbar spine, 6 mm for the thoracic spine, and 4 mm for the cervical spine. The intradiscal height should not reach zero before the onset of functional or mechanical failure. If this occurs, the test is considered a failure. The user of the test method should select the intradiscal height that is appropriate for the device being tested.

6.3 ~~The~~ *Axial Compression Test Apparatus*—The actuator of the testing machine is connected to the pushrod by a minimal friction ball and socket joint or universal joint (that is, unconstrained in bending). The pushrod is connected to the superior fixture by a minimal friction sphere joint (that is, unconstrained in bending and torsion). The hollow pushrod should be of minimal weight so as to be considered a “two-force” member. It thus applies to the intervertebral body fusion device assembly a resultant force directed along the pushrod's axes and located at the center of the superior fixture's sphere joint (the geometric center of the device being tested). For the fatigue tests, the device is placed between two polyacetal blocks, which are rigidly attached to the metal blocks (Fig. 2). For the static tests, metal blocks are to be used, which could be incorporated as an integral part of the superior and inferior fixtures. The blocks are to have surfaces that mate geometrically with the intervertebral device similar to how the device is intended to mate with vertebral end plates. The test apparatus will be assembled such that the Z axis of the intervertebral device is initially coincident with the pushrod's axis and collinear with the axis of the testing machine's actuator and load cell. The length of the pushrod between the center of the ball-and-socket joint to the center of the spherical surface is to be a minimum of 38 cm. This is required to minimize deviation of the pushrod's axis (direction of applied force, F) from that of the test machine's load cell axis. In other words, this is to minimize the error in using and reporting that the force indicated by the load cell “ F_{ind} ” is the applied load, F , and is equal to the compressive force, F_z , on the intervertebral body fusion device assembly. For example, a 1-mm displacement of the spherical surfaces center in the XY plane would produce an angle between axes of 0.15°, (10 mm producing 1.5°). Fig. 2 is a schematic of this test set up.

6.4 *Compression-Shear Testing Apparatus*—The compression-shear test apparatus (Fig. 3) with exception of the inferior fixture is identical to the axial compression apparatus (Fig. 2). The inferior fixture is to be designed to orient the initial position of the intervertebral device's Z axis at 45° flexion relative to the pushrod's axis. The resultant force, F , being applied to the intervertebral body fusion device assembly passes through the center of the superior fixture's spherical surface and is coincident with the pushrod's axis. Thus a combined compressive load F_z and an anterior shear load F_x is created, which initially are equal in magnitude and pass through the geometric center of the intervertebral body fusion device assembly.

6.5 *Torsion Testing Apparatus*—The torsion test apparatus (Fig. 4) is similar to the axial compression test apparatus (Fig. 2) with exception of the pushrod interconnections. The actuator of the testing machine must be connected to the pushrod by a minimal friction (that is, unconstrained in bending) universal joint to be able to transmit torsional moment in addition to axial load. The pushrod is connected to the superior fixture by a spherical gimbal mechanism to apply combined compressive force, F , and moment, M , with negligible bending moment to the intervertebral body fusion device assembly. Two examples of a gimbal mechanism are: (1) a sphere with pegs engaged in a slotted yoke attached to the pushrod (Fig. 4) and (2) a pair of spherical surfaces with interdigitating tongue and grooves located 90° to each other (Fig. 5). The test apparatus is to be assembled so that the Z axis of the intervertebral body fusion device assembly is initially coincident with the pushrod's axis and collinear with the axis of the testing machine's actuator and load cell. This setup is designed so that the initially applied load, F , and moment, M , are equal to the compression force, F , and torsional moment, M , on the intervertebral body fusion device assembly.

7. Sampling

7.1 All components in the intervertebral body fusion device assembly shall be previously unused parts only; no implants shall be retested.

7.2 Each pair of polyacetal blocks shall be used for one test only. Metal blocks may be reused if undamaged.

7.3 The test assemblies (that is, intervertebral body fusion device assembly and polyacetal blocks) shall be labeled and shall be maintained according to good laboratory practice. The test assembly can be disassembled to facilitate examination of surface conditions.

7.4 All static tests should have a minimum of five test samples.

7.5 The user of the test method should select the necessary loads to plot a well-defined max load-cycle to failure trend and to establish the maximum run out load. This trend must be comprised of at least six data points. The precision in establishing the value for the maximum run out load should be less than 10 % of the ultimate load or moment for a given test. A regression analysis will be conducted on the load or moment versus number of cycles to failure data.

8. Procedure for Static Tests

8.1 The intervertebral body fusion device assembly is to be inserted between two prepared metal blocks having the appropriate matching geometry of the intervertebral body fusion device assembly (Fig. 7). The intradiscal height, H , shall be constant for all tests for an intervertebral body fusion device assembly of a given size.

8.2 The load, F , and moment, M_z , are to be applied as described in Section 6 of this test method in position control at a rate no greater than 25mm/min or 60°/min (radians/minute) until functional or mechanical failure of the intervertebral body fusion device assembly is obtained.

8.3 Physiological compressive preloads of 100, 300, and 500 N for cervical, thoracic and lumbar intervertebral body fusion device assemblies, respectively, are required for the static torsion test to avoid separation of the blocks during testing. Other loads may be used with adequate justification.

8.4 The load displacement curve shall be recorded. The yield displacement (mm or degrees or radians), stiffness (N/mm or N*mm/degree (radian)), yield load or moment (N or N*mm), ultimate displacement (millimetres or degrees or radians), and ultimate load or moment (N or N*mm) are to be established.

9. Procedure for Dynamic Tests

9.1 An intervertebral body fusion device assembly is to be inserted between two prepared polyacetal blocks having the appropriate matching geometry of the intervertebral body fusion device assembly (Fig. 7). The intradiscal height, H , shall be constant for all tests for an intervertebral body fusion device assembly of a given size.

9.2 Load, F , and moment, M_z , are to be applied as described in Section 6 of this test method in load control. The user of this standard test method should select the necessary loads to develop a well-defined load-cycle to failure trend comprised of a minimum of six data points. Suggested maximum loads for initial dynamic tests are 25, 50, and 75 % of the ultimate static load. A semi-log fatigue graph of maximum applied load, F , or moment, M_z , versus the number of cycles to failure is to be plotted. The end of the test is defined as functional failure of the construct or attainment of 5 000 000 cycles without functional failure. However, any mechanical failure should be noted at the 5 000 000 cycle point (for example, surface wear, crack initiation, crack

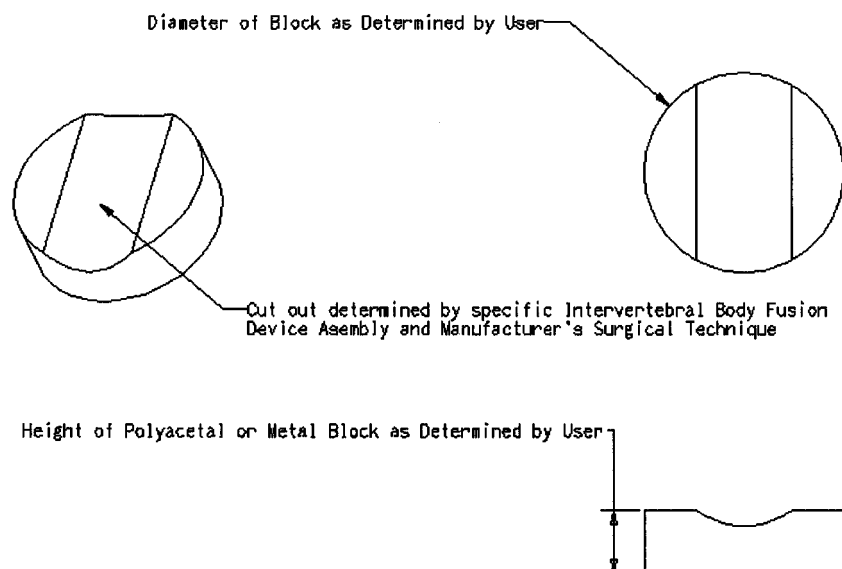

FIG. 7 Polyacetal or Metal Test Block

propagation, and so forth). The maximum runout load is to be determined. The precision in establishing the maximum runout load should not deviate more than 10 % of the static strength of the intervertebral body fusion device assembly.

9.3 An R value of 10 shall be used for the axial compression and compression-shear tests, and an R value of -1 shall be used for the torsional testing.

9.4 The frequency of the dynamic test shall be determined by the user of this test method and recorded (see X1.9).

10. Report

10.1 The report shall specify the intervertebral body fusion device assembly components, the intervertebral body fusion device assembly, the intended spinal location, and the numbers of specimens tested. Any pertinent information about the components such as name, design, manufacturer, material, part number, lot number, and size shall also be reported. All information necessary to reproduce the assembly shall also be included.

10.2 Exact loading configurations for the testing apparatus shall be included. All deviations (with adequate justification) from the recommended test procedures shall be reported, and all relevant testing parameters shall be reported. Rationale for testing configurations not used shall also be reported.

10.3 The report of the static mechanical testing shall include a complete description of all failures (functional and mechanical), modes of failure, and deformation of the intervertebral body fusion device assembly or test apparatus. The static mechanical test report shall include the following:

10.3.1 All load-displacement curves are to be included in an appendix. These curves should illustrate the pertinent static data. All static test data, including the mean and standard deviation will be reported for yield displacement (mm or degrees or radians), yield load or moment (N or N*mm), stiffness (N/mm or N*mm/degree (radian)), ultimate displacement (mm or degrees or radians), and ultimate load or moment (N or N*mm).

10.4 The report on the dynamic testing shall include the following:

10.4.1 Final sample sizes, test frequencies, and semi-log load versus number of cycles to failure are to be listed for each type of fatigue test conducted. The highest load level for the specimen enduring 5 000 000 cycles without functional or mechanical failure should be stated as the maximum runout load or moment. Specimens that have not mechanically or functionally failed before 5 000 000 cycles should be indicated.

10.4.2 All initial and secondary failures, modes of failure, and deformations of components should be reported for the intervertebral body fusion device assembly. Fatigue failures should be described completely with the following information: failure or crack initiation site, propagation zone, and ultimate failure zone. Any wear or loosening of the assembly must be described. In addition, the testing environment should be described. Any other noteworthy observations should be included.

10.4.3 A regression analysis of the load or moment versus number of cycles to failure data should be reported.

11. Precision and Bias

11.1 *Precision*—Data establishing the precision of this test method have not yet been obtained.

11.2 *Bias*—No statement can be made as to bias of this test method since no acceptable reference values are available nor can they be obtained because of the destructive nature of the tests.

12. Keywords

12.1 dynamic test methods; intervertebral body fusion device; spinal implants; static test methods

APPENDIX

(Nonmandatory Information)

X1. STATEMENT OF RATIONALE FOR TEST METHODS

X1.1 Intervertebral body fusion device assemblies are manufactured in a variety of sizes, materials, and shapes with various design features. The purpose of this test method is to allow for a consistent, repeatable comparison of different intervertebral body fusion device assemblies through a comprehensive series of mechanical tests.

X1.2 All of the spinal implants that fall into the category of intervertebral body fusion device assemblies are intended for the purpose of arthrodesis, and therefore, all of the implants will reside in the disc space with varied orientations and methods of fixation to the adjacent vertebral bodies. This test method will allow for comparison of these devices since the methods and loading configuration remains consistent regardless of method of application.

X1.3 The proposed test configurations are based on anatomical dimensions.

X1.4 This ~~standard test method~~ covers the static and dynamic evaluation of intervertebral body fusion device assemblies. The purpose of an intervertebral body fusion device assembly is to provide short-term stabilization of the spine to facilitate fusion; it

is for this relatively short functional life duration that these dynamic tests seek to simulate. This ~~standard test method~~ does not attempt to address the questions related to long-term performance in the absence of a successful arthrodesis.

X1.5 The influence of saline or other simulated or actual body fluids may have an effect on the performance of the assemblies and therefore should be considered as an adjunct to testing in an ambient environment (dry) as described in this test method. The individual investigator may wish to investigate different environmental testing agents to simulate body fluid for subsequent testing such as saline or other lubricants.

X1.6 If the devices are known to be temperature and environment dependent, testing should be conducted in physiologic solution. Devices that require physiologic solution for testing should be tested in the same type solution for comparison purposes.

X1.7 Polyacetal blocks are used to simulate the vertebral bodies in dynamic testing to avoid introducing wear associated variables to the test. However, metallic blocks are used for the static testing of intervertebral body fusion device assemblies so that the stiffness measurements reflect that of the intervertebral device itself.

X1.8 Since the main purpose of an intervertebral body fusion device assembly is fusion, the maximum runout load or moment is defined from a clinical standpoint. Since fusion should occur well within one year of implantation, the device should withstand normal intervertebral spinal loading until fusion occurs. If one uses a factor of safety of 2.5, the intervertebral fusion device assembly should withstand 2.5 years of loading, which corresponds to 5 million cycles⁴.

X1.9 Frequencies over 10 Hz may result in heating and subsequent melting of the test blocks. Since this phenomenon is device and environment specific, the user of this test method is left to discern an appropriate cyclic frequency.

X1.10 The purpose of this test method is to allow for the comparison of different intervertebral body fusion device assemblies and does not attempt to dictate performance standards for these types of devices since *in vivo* spinal loading is very complex, highly variable, and not yet fully understood.

X1.11 On the basis of peer reviewed clinical results⁵ presented at the November 2001 symposium, Subcommittee F04.25 came to the conclusion that a pushout test method is not the appropriate method for evaluating the implant's resistance to expulsion.

⁴ Hedman, T.P., Kostuick, J.P., Fernie, G.R., Hellier, W.G., "Design of an Intervertebral Disc Prosthesis," *Spine*, 16: 65, 1991, pp. S 256-260.

⁵ Theiss, Steven M., "Extrusion of Lumbar Interbody Fusion Cages: Clinical Examples," *Spinal Implants: Are We Evaluating Them Appropriately?*, ASTM STP 1431, ASTM International, West Conshohocken, PA 19428.

ASTM International takes no position respecting the validity of any patent rights asserted in connection with any item mentioned in this standard. Users of this standard are expressly advised that determination of the validity of any such patent rights, and the risk of infringement of such rights, are entirely their own responsibility.

This standard is subject to revision at any time by the responsible technical committee and must be reviewed every five years and if not revised, either reapproved or withdrawn. Your comments are invited either for revision of this standard or for additional standards and should be addressed to ASTM International Headquarters. Your comments will receive careful consideration at a meeting of the responsible technical committee, which you may attend. If you feel that your comments have not received a fair hearing you should make your views known to the ASTM Committee on Standards, at the address shown below.

This standard is copyrighted by ASTM International, 100 Barr Harbor Drive, PO Box C700, West Conshohocken, PA 19428-2959, United States. Individual reprints (single or multiple copies) of this standard may be obtained by contacting ASTM at the above address or at 610-832-9585 (phone), 610-832-9555 (fax), or service@astm.org (e-mail); or through the ASTM website (www.astm.org).