



Standard Practice for Measuring Viscosity of Glass Above the Softening Point¹

This standard is issued under the fixed designation C 965; the number immediately following the designation indicates the year of original adoption or, in the case of revision, the year of last revision. A number in parentheses indicates the year of last reapproval. A superscript epsilon (ϵ) indicates an editorial change since the last revision or reapproval.

1. Scope

1.1 This practice covers the determination of the viscosity of glass above the softening point through the use of a platinum alloy spindle immersed in a crucible of molten glass. Spindle torque, developed by differential angular velocity between crucible and spindle, is measured and used to calculate viscosity. Generally, data are taken as a function of temperature to describe the viscosity curve for the glass, usually in the range from 1 to 10^6 Pa·s.

1.2 Two procedures with comparable precision and accuracy are described and differ in the manner for developing spindle torque. Procedure A employs a stationary crucible and a rotated spindle. Procedure B uses a rotating crucible in combination with a fixed spindle.

1.3 *This standard does not purport to address all of the safety concerns, if any, associated with its use. It is the responsibility of the user of this standard to establish appropriate safety and health practices and determine the applicability of regulatory limitations prior to use.*

2. Referenced Documents

2.1 *ASTM Standards:*

C 162 Terminology of Glass and Glass Products²

E 220 Method for Calibration of Thermocouples by Comparison Techniques³

3. Significance and Use

3.1 This practice is useful in determining the viscosity-temperature relationships for glasses and corresponding useful working ranges.

4. Apparatus

4.1 The apparatus shall consist of an electrically heated furnace equipped with a temperature controller, temperature measuring equipment, a platinum alloy spindle,⁴ a crucible,⁴ a

device to rotate spindle or crucible, and equipment to measure torque.

4.1.1 Procedure A employs an electrically heated tube-type furnace with a fixed support for the crucible as shown in Fig. 1. A platinum alloy resistance-heated crucible also may be used.

4.1.2 Procedure B employs a similar furnace but with a removable, rotatable crucible support as shown in Fig. 2.

4.1.3 Furnaces other than resistance-wound muffle types may be used provided they give uniform and stable temperature conditions. Temperature differences greater than 3°C within the crucible (in glass) are excessive for high precision measurements.

4.1.4 A temperature controller shall be provided for maintaining the glass temperature within $\pm 2^\circ\text{C}$ of a specified temperature.

4.1.5 Temperatures shall be measured with Type R or S thermocouples calibrated in accordance with Method E 220 in conjunction with a calibrated potentiometer or solid state instrumentation capable of 0.5°C accuracy. An immersion thermocouple is recommended but a thermocouple in air may be used provided measurements show equivalency.

4.1.6 A crucible to contain the glass similar to those shown in Fig. 3 preferably shall be fabricated from a platinum alloy, but a refractory material may be used provided it does not contaminate the glass.

4.1.7 A platinum alloy spindle with the geometry shown in Fig. 4 is recommended. An alternative design has a hollow shaft to house the thermocouple (junction at the center of the large diameter portion) which has the advantage of proximity, but the disadvantage of possible electrical disconnection during torque measurement.

4.1.8 A measurement system⁵ is necessary for measurement of spindle torque to an accuracy of 1 %.

5. Preparation of Test Glass

5.1 Select a mass of glass that is free of foreign material. Break or cut glass into pieces, each weighing about 10 to 50 g, and place the correct quantity into the crucible that will make the molten charge reach a level at some fixed distance (several millimetres) above the point where the spindle narrows down.

¹ This practice is under the jurisdiction of ASTM Committee C14 on Glass and Glass Products and is the direct responsibility of Subcommittee C14.04 on Physical and Mechanical Properties.

Current edition approved Oct. 10, 1996. Published December 1996. Originally published as C 965 – 81. Last previous edition C 965 – 81 (1996)^{e2}.

² *Annual Book of ASTM Standards*, Vol 15.02.

³ *Annual Book of ASTM Standards*, Vol 14.03.

⁴ Spindles and crucibles manufactured from 90% Pt–10% Rh or 80% Pt–20% Rh alloys have been found satisfactory for this purpose.

⁵ Equipment such as the Brookfield RVT or HBT manufactured by Brookfield Engineering Laboratories, Inc., 240 Cushing St., Stoughton, MA 02072, or equivalent has been found satisfactory for this purpose.

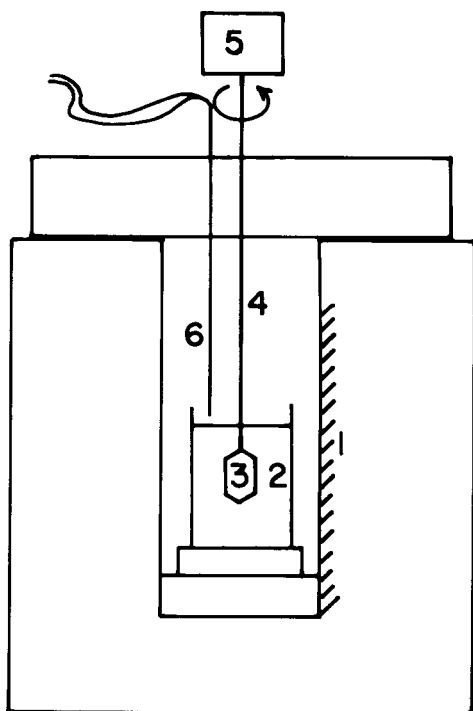

- 1—Furnace Winding
- 2—Crucible
- 3—Spindle
- 4—Shaft
- 5—Viscometer (providing both rotation and torque measurement)
- 6—Thermocouple

FIG. 1 General Arrangement for Rotating Spindle, Fixed Crucible Scheme (Procedure A)

The weight of glass required can be approximated satisfactorily with the following expression for a cylindrical crucible:

$$W_T = [\pi d^2(L + h)/4 - V_s]\rho (1 - 0.0007\alpha) \quad (1)$$

where:

- h = distance between crucible floor and spindle tip, mm (generally greater than 10 mm to avoid end effects)
- W_T = glass charge weight at room temperature, g,
- d = inside diameter of crucible, mm,
- L = immersed portion of spindle, mm,
- V_s = volume of immersed portion of spindle, mm³,
- ρ = density of glass at room temperature, g/cm³, and
- α = 0 to 300°C thermal expansion coefficient, cm/cm·°C ($\times 10^7$).

Avoid very small pieces of glass in the charge as they tend to make the molten glass seedy.

5.2 Place the filled crucible in proper position in the furnace and heat to a temperature that lowers the viscosity of glass sufficiently to allow trapped air bubbles to be released. This temperature should be below the original melting temperature to avoid reboil. If reboil occurs, allow additional time for the glass to clear. Hold at this temperature at least 20 min before starting measurements.

6. Calibration and Viscosity Determination

6.1 The use of several standard reference glasses (see

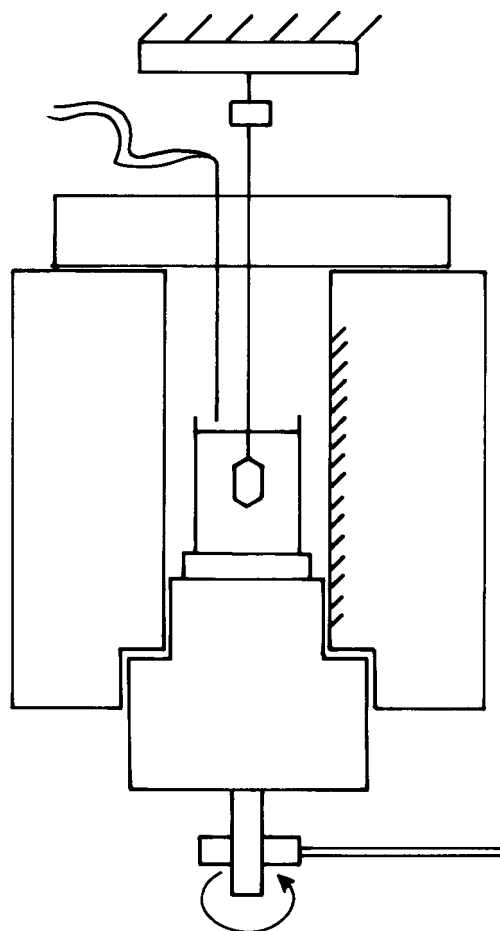

NOTE 1—Details are the same as in Fig. 1 except that the viscometer is replaced by a torque measuring device, and the crucible is mounted on a removable rotatable stand.

FIG. 2 General Apparatus Arrangement for Rotating Crucible Scheme (Procedure B)

Appendix X1),⁶ available from the National Institute of Standards and Technology, is recommended. These provide a wide range of temperatures and viscosities for calibration.

6.2 For constant angular velocity rotation:

$$\eta \propto \Omega/\omega \quad (2)$$

where:

- η = viscosity,
- Ω = torque, and
- ω = angular velocity

For aperiodic return:

$$\eta \propto t/\ln(\theta_2/\theta_1) \quad (3)$$

where:

t = time to traverse θ_2 to θ_1 angular displacement.

6.3 Using the standard reference glasses, establish linear plots of η versus Ω/ω or η versus $t/\ln(\theta_2/\theta_1)$, or both. By proper selection of glasses the same viscosity can be attained at different temperatures; this can be helpful in establishing

⁶ See NIST Special Publication 260, NIST Standard Reference Materials, National Institute of Standards and Technology, Gaithersburg, MD.

TABLE 3

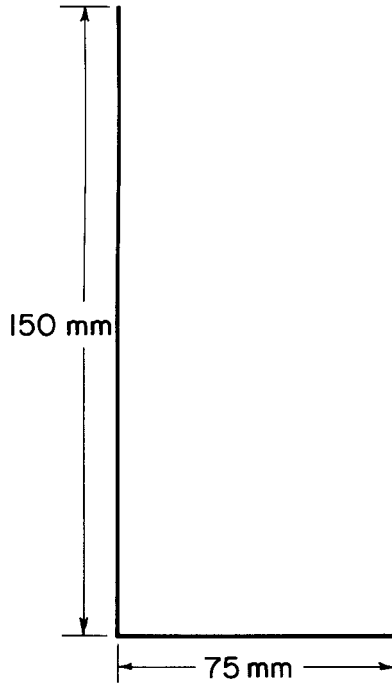

Platinum alloy crucible made from 0.10 to 0.12-cm sheet.

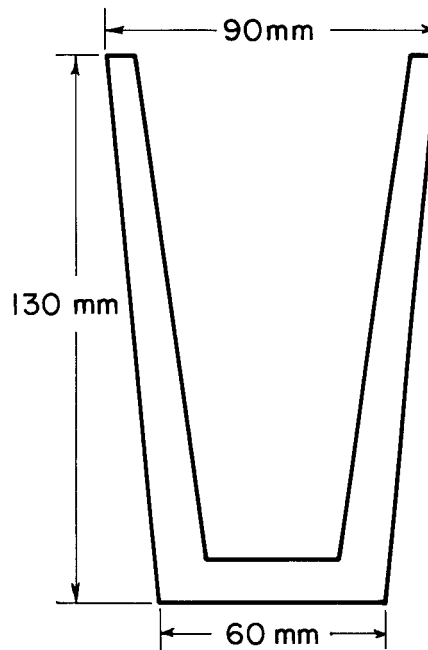

Refractory crucible of suitable composition.

FIG. 3 Two Types of Crucibles

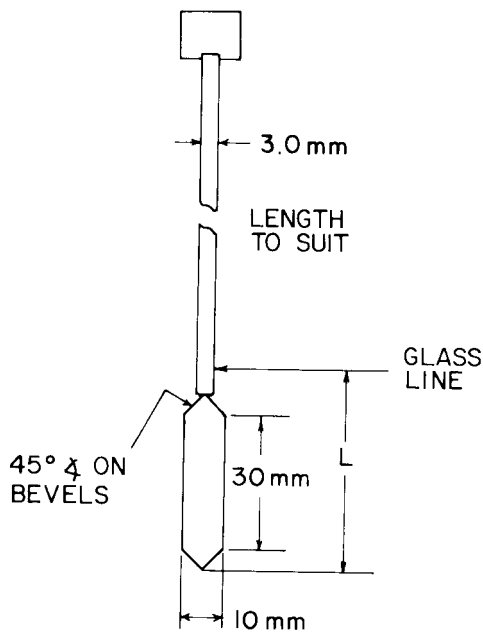

FIG. 4 Typical Platinum Alloy Spindle

whether temperature errors are present. Nonlinearity of these plots indicate a problem in the apparatus which must be corrected. These linear plots, once well-established, are used to derive viscosity of unknown test glasses. A linear regression of the calibration data is recommended.

7. Procedure

7.1 Center the spindle over the crucible with a preset fixture that assures concentric alignment and lower the spindle into the

molten glass. The displacement between spindle end and crucible floor shall be sufficient to minimize end effects (generally 1 cm or more will suffice). Allow a few minutes for the glass line to stabilize. Connect the torque-measuring system.

7.2 Depending on whether Procedure A or Procedure B is being employed, start rotation of either spindle or crucible. Measure and record the torque after it has stabilized. Measure and record the temperature at the time of torque measurement.

7.3 Adjust the temperature controller to change the temperature for the next set of readings. Allow sufficient time for temperature stabilization, and repeat 7.2. Torque readings may be taken on cooling or heating providing that data so taken are in agreement with steady-state measurements.

7.4 Torque-temperature data are repeated to provide sufficient data to describe the viscosity-temperature relationship.

7.5 With a steel wire suspension as the torque measurement member, viscosities above 10^3 Pa·s require very stiff (large diameter) wire. An alternative to constant angular velocity rotation is to displace the spindle some 30 to 40° from the rest (0°) position and allow the wire suspension to drive the spindle back to null. Select two angles relative to null, θ_2 and θ_1 , ($\theta_2 > \theta_1$), and measure the time required for the spindle to pass from θ_2 to θ_1 on return to null. This is called *aperiodic return*.

7.6 After all measurements have been taken, raise the temperature so the spindle can be easily raised out of the melt. After clinging molten glass has dripped back into the crucible, remove the spindle from the furnace. It is sometimes convenient to remove the crucible when hot and pour the molten glass out, especially if the crucible is reusable.

8. Calculation

8.1 Take the average of the torque or time readings depending whether the mode of observation is constant angular velocity or aperiodic return. Calculate Ω/ω or $t/\ln(\theta_2/\theta_1)$, or both, and from the calibration function calculate the viscosity.

8.2 Plot derived viscosities as a function of temperature and draw a smooth curve to fit the data. For most glasses the data can be fitted to the following expression for mathematical smoothing:

$$\log_{10}\eta = A + B/T - T_o \quad (4)$$

where:

T = temperature, °C, and
 $A, B,$ and T_o = adjustable constants.

9. Report

9.1 Report the following information:

- 9.1.1 Designation of glass, source, and date,
- 9.1.2 Viscosity-temperature plot and mathematical fit if derived, and
- 9.1.3 Date of test and name of operator.

10. Precision and Bias

10.1 Proper calibration with viscosity SRM's eliminates bias and makes the accuracy of measurement equal to the uncertainty of the values given in the SRM certificates.

10.2 Precision will vary from laboratory to laboratory and apparatus to apparatus. It can be established by multiple determinations for the same glass using standard statistics. Following best practices, the standard deviation for a single apparatus would not be expected to exceed a few (<5) percent.

11. Keywords

11.1 concentric cylinders method; glass; viscosity

APPENDIX

(Nonmandatory Information)

X1. STANDARD SAMPLES FOR VISCOSITY DETERMINATIONS

X1.1 Standard reference glasses are available as viscosity standards for the calibration and standardization of instruments of the rotating cylinder, fiber elongation, beam-bending, and

parallel-plate types. A certificate listing the certified property values is issued with each sample of standard reference glass.⁷ Available samples are shown in Table 1:

⁷ Samples are available from the Standard Reference Materials Program, National Institute of Standards and Technology, Gaithersburg, MD 20899.

TABLE 1 X1.1 Standard Samples

SRM Nos.	Viscosity (Pa-s) at Indicated Temperature, °C											Softening Point, °C	Annealing Point, °C	Strain Point, °C
	10	10 ²	10 ³	10 ⁴	10 ⁵	10 ⁶	10 ⁷	10 ⁸	10 ⁹	10 ¹⁰	10 ¹¹			
710a	1464	1205	1037	918	731	545	504
711	1327.1	1072.8	909.0	794.7	710.4	645.6	594.3	552.7	518.2	489.2	464.5	602	432	392
717a	1555	1256	1065	932	834 ^A	758 ^A	697 ^A	647 ^A	606 ^A	570 ^A	540 ^A	719	513	470

^A Not certified, for information only.

ASTM International takes no position respecting the validity of any patent rights asserted in connection with any item mentioned in this standard. Users of this standard are expressly advised that determination of the validity of any such patent rights, and the risk of infringement of such rights, are entirely their own responsibility.

This standard is subject to revision at any time by the responsible technical committee and must be reviewed every five years and if not revised, either reapproved or withdrawn. Your comments are invited either for revision of this standard or for additional standards and should be addressed to ASTM International Headquarters. Your comments will receive careful consideration at a meeting of the responsible technical committee, which you may attend. If you feel that your comments have not received a fair hearing you should make your views known to the ASTM Committee on Standards, at the address shown below.

This standard is copyrighted by ASTM International, 100 Barr Harbor Drive, PO Box C700, West Conshohocken, PA 19428-2959, United States. Individual reprints (single or multiple copies) of this standard may be obtained by contacting ASTM at the above address or at 610-832-9585 (phone), 610-832-9555 (fax), or service@astm.org (e-mail); or through the ASTM website (www.astm.org).