



# Standard Test Method for Multiple-Cycle Accelerated Aging Test (Automatic Boil Test) for Exterior Wet Use Wood Adhesives<sup>1</sup>

This standard is issued under the fixed designation D 3434; the number immediately following the designation indicates the year of original adoption or, in the case of revision, the year of last revision. A number in parentheses indicates the year of last reapproval. A superscript epsilon ( $\epsilon$ ) indicates an editorial change since the last revision or reapproval.

## 1. Scope

1.1 This test method covers a procedure for testing the durability of wood adhesives that may be suitable for exterior (wet use) exposure conditions. The possible use of adhesives suitable for evaluation includes, but is not limited to those used for laminating large members, manufacturing plywood, or fabricating wood joints such as finger or scarf joints. This practice is not suitable for interior type glues.<sup>2,3</sup>

1.2 The test does not evaluate for any biological effects.

1.3 The test subjects specimens to a large number of alternate boil/dry cycles.

1.4 The values stated in SI units are to be regarded as the standard. The inch-pound units in parentheses are provided for information only.

1.5 *This standard does not purport to address all of the safety concerns, if any, associated with its use. It is the responsibility of the user of this standard to establish appropriate safety and health practices and determine the applicability of regulatory limitations prior to use.*

## 2. Referenced Documents

### 2.1 ASTM Standards:

D 906 Test Method for Strength Properties of Adhesives in Plywood Type Construction in Shear by Tension Loading<sup>4</sup>

D 907 Terminology of Adhesives<sup>4</sup>

D 2339 Test Method for Strength Properties of Adhesives in Two-Ply Wood Construction in Shear by Tension Loading<sup>4</sup>

D 4442 Test Methods for Direct Moisture Content Measurement of Wood and Wood Based Materials<sup>5</sup>

E 122 Practice for Choice of Sample Size to Estimate a Measure of Quality for a Lot or Process<sup>6</sup>

## 3. Terminology

3.1 *Definitions*—Definitions of terms in this test method may be found in Terminology D 907.

## 4. Summary of Test Method

4.1 The lumber is selected, adhesive obtained, and test specimens prepared.

4.2 The specimens are subjected to the required number of boil/dry cycles.

4.3 The specimens are withdrawn from the test at the required periodic intervals.

4.4 The designated number of specimens are tested in tensile shear at the end of the specified number of boil/dry cycles.

4.5 Plot shear strength, kPa (psi), or percent of wood failure, or both, versus the number of boil/dry cycles to which the specimens have been subjected.

4.6 The graph is compared for the test adhesives. Because of the variables occurring in wood, a known performance adhesive control should be run for each test set being evaluated.

## 5. Significance and Use

5.1 This test method is intended to differentiate between the exterior durability of two or more adhesives. At present, this is done by comparing the adhesives as described in 4.5 and 4.6 rather than by assigning absolute numerical values for durability performance.

5.2 The test method as described is for comparing potential long-term durability rather than for use as a quality control procedure. This makes it suitable for research, adhesive evaluation, process evaluation, and product design. A modification could be made, that is, shorten the number of cycles used so the test method would be suitable for quality control in production mills. The results obtained for a particular adhesive can be used to show how many cycles are required for a mill quality control test of that adhesive.

5.3 The test method assumes that boil/dry cycling is an adequate and useful accelerated aging technique. Evaluation of long-term durability of adhesives in wood joints under severe service conditions, including extended exterior exposure, is a complex field, and no entirely reliable short-term test is known to ensure that a new type of adhesive system will satisfactorily

<sup>1</sup> This test method is under the jurisdiction of ASTM Committee D-14 on Adhesives, and is the direct responsibility of Subcommittee D14.30 on Wood Adhesives.

Current edition approved March 10, 2000. Published May 2000. Originally published as D 3434 – 75. Last previous edition D 3434 – 96.

<sup>2</sup> Walser and Colbeck, "Bond-Degrade Accelerating Machine Helps Predict Bond Life," *Adhesives Age*, Vol 10(11), November 1967, pp. 33–35.

<sup>3</sup> Kreibich and Freeman, "Development and Design of an Accelerated Boil Machine," *Forest Products Journal*, Vol 18, No. 12, December 1968.

<sup>4</sup> *Annual Book of ASTM Standards*, Vol 15.06.

<sup>5</sup> *Annual Book of ASTM Standards*, Vol 04.10.

<sup>6</sup> *Annual Book of ASTM Standards*, Vol 14.02.

resist all of the chemical, moisture, microorganism, and solvent effects that such severe service may involve. Except for effects of microorganisms and other similar biological influences, this test method has proven very useful for comparison purposes to distinguish between adhesive systems of different degree of durability to the usual temperature, moisture, and cyclic moisture conditions. It has proven very useful to distinguish between bondlines, made with adhesives of proven chemical and biological durability, that were properly used in production to resist the mechanical and moisture effects that such joints must withstand in severe service over extended periods of exposure. It does not, in itself, assure that new types of adhesives will always withstand actual exterior or other severe service.

**6. Apparatus**

6.1 Due to the large number of boil/dry cycles involved, an automated piece of test equipment is required. A schematic diagram of one system found suitable is shown in Fig. 1; a photograph in Fig. 2. The equipment shown automatically boils and dries the test specimens as required.

6.2 A tensile shear tool is required such as described in Test Method D 2339.

**7. Test Specimens**

7.1 *Wood Substrate:*

7.1.1 *For Lumber Laminating Adhesives*—Condition the wood at  $23 \pm 2^\circ\text{C}$  ( $73.4 \pm 3.6^\circ\text{F}$ ) and a relative humidity of 50 to 70 % (preferably 65 %) until a moisture content of 8 to 14 % (preferably 9 to 12 %) has been attained. Freshly surface both sides of each lamination before bonding with  $6.3 \pm 0.25\text{-mm}$  ( $0.25 \pm 0.01\text{-in}$ ) thick lumber. Since adhesives join materials by surface attachment, care must be taken to ensure a uniform reproducible surface representative of actual construction.

Typical surfaces include sawed, planed, sanded, and skived. Detailed surface preparation procedures used must be included in the report (see 10.1).

7.1.1.1 Specimen moisture content (MC) conditions called for in this test method should be checked in accordance with Test Methods D 4442.

7.1.2 *For Plywood Adhesives*—Prepare the test specimen in accordance with Test Method D 906.

7.1.3 *Miscellaneous Specimens*—Other wood joints, such as finger or scarf joints, or other wood-based materials, such as particleboard, hardboard, or insulating board, may also be evaluated.

7.2 *Adhesive*—Store the adhesive or its components at the manufacturer’s recommended conditions.

7.3 *Bonding Procedure:*

7.3.1 It has been found convenient to fabricate large two- and three-ply blocks, which are subsequently cut into a number of test specimens. A 140 by 140-mm ( $5\frac{1}{2}$  by  $5\frac{1}{2}$ -in) block will yield four specimens and one 140 by 200-mm ( $5\frac{1}{2}$  by 8-in) block will yield eight specimens.

7.3.2 Mix and apply the adhesive(s) to the surface(s) to be bonded in accordance with the manufacturer’s instructions. If the processes are being evaluated, prepare specimens reflecting the limits of the typical process conditions.

7.3.3 Age the large blocks for at least 1 week at  $23 \pm 2^\circ\text{C}$  ( $73.4 \pm 3.6^\circ\text{F}$ ) and a relative humidity of 50 to 70 % (preferably 65 %) before cutting into the smaller test specimen.

7.4 *Test Specimen Fabrication:*

7.4.1 Fig. 3 shows the preferred test specimens and dimensions for lumber laminating adhesives. The same specimens can be used with veneer when evaluating plywood adhesives. The two-ply specimen will be satisfactory when bondline performance parallel to the grain is to be evaluated; the

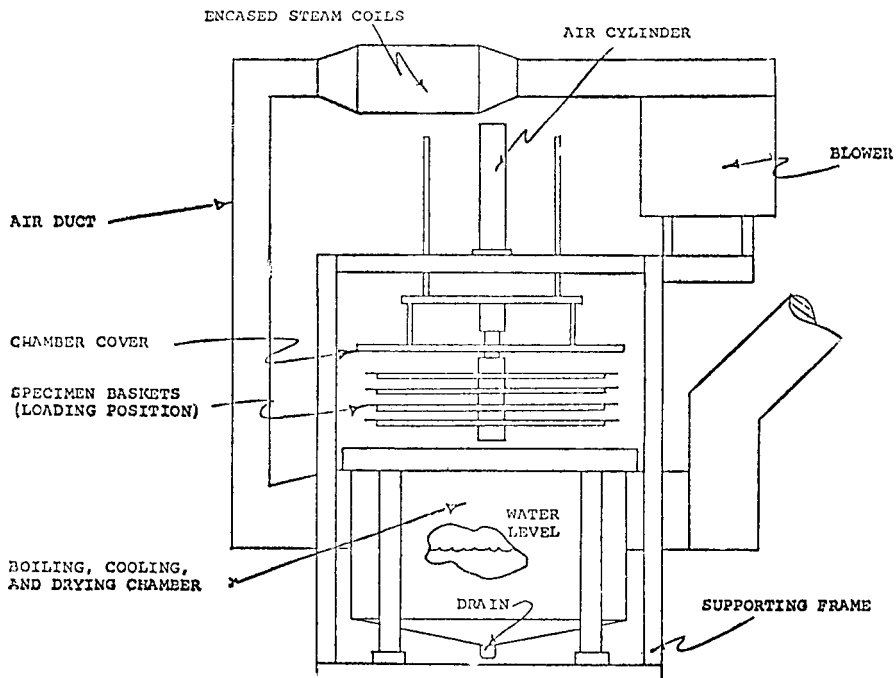
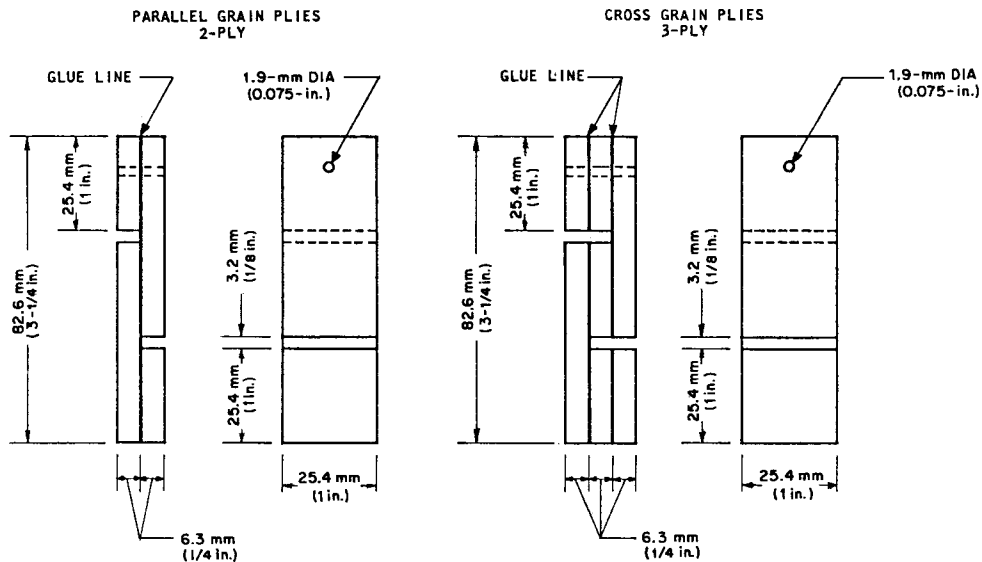

FIG. 1 Automatic Boil Machine



FIG. 2 Automatic Boil Machine



NOTE 1—All laminations made with 6.3-mm (1/4 in.) Lumber.

FIG. 3 Test Specimens

three-ply specimen when cross-grain bondline performance is to be evaluated.

7.4.2 Cut large blocks into test specimens as shown in Fig. 3. Exercise care in grooving the specimens to ensure that the

cut extends to, but not beyond, the bondline as shown in Fig. 3.

7.4.3 Fig. 4 shows a suitable test specimen for evaluating finger joints.

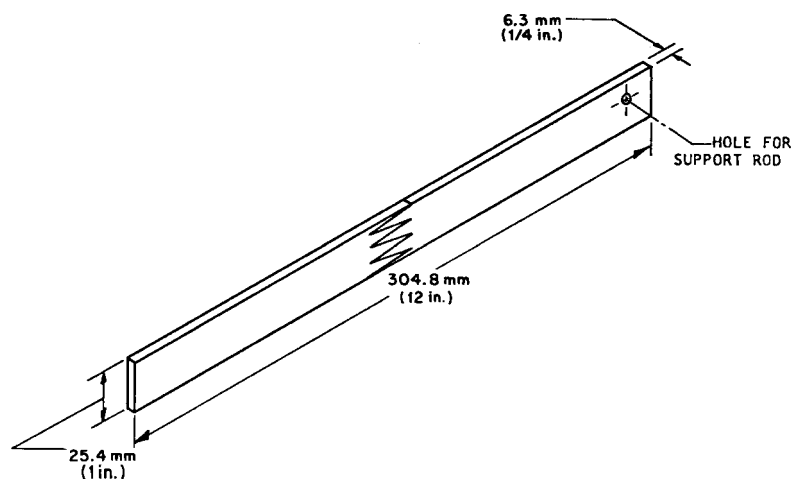

**FIG. 4 Typical Finger Joint Specimen**

7.4.4 Different specimen dimensions may be used for special applications but the boil/dry cycling time periods may have to be modified to allow for complete wetting and drying.

#### 7.5 Number of Test Specimens:

7.5.1 Ninety specimens are required for each adhesive, process variable, lay-up type, substrate material, etc., to be evaluated.

7.5.2 Randomly divide each set of 90 specimens into nine groups of ten each and sequentially number them for identification. (Depending upon the statistical accuracy desired, additional specimens may be desired; see Practice E 122).

7.5.3 Include twelve additional test specimens for moisture content determinations during aging.

## 8. Procedure

### 8.1 Controls:

8.1.1 *Dry Controls*—Test ten specimens dry in tensile shear (no cycling), using the apparatus indicated in 6.2. Record the ultimate shear strength and percent wood failure. The dry control values obtained shall be at least as high as the recommended values obtained by the adhesive manufacturer or the normal values for that type of adhesive, or both.

8.1.2 *Wet Controls*—Submerge ten specimens for 3 days in  $23 \pm 2^\circ\text{C}$  ( $73.4 \pm 3.6^\circ\text{F}$ ) water. Position the specimens in such a way that water can readily circulate around all sides of each specimen. Test wet in tensile shear in accordance with 8.1.1. Record the results.

### 8.2 Accelerated Aging Cycles:

8.2.1 *Positioning of Test Specimens*—Position the test specimens in the automatic cycling machine in such a way that air or water can readily circulate around all sides of each specimen.

8.2.2 *Cycle 1*—Submerge the specimens for 10 min in boiling water.

### 8.2.3 All Following Cycles Consist of:

8.2.3.1 Dry the specimens for 4 min with  $23 \pm 2^\circ\text{C}$  ( $73.4 \pm 3.6^\circ\text{F}$ ) circulating air at  $1.74 \pm 0.29$  m/s ( $300 \pm 50$  ft/min).

8.2.3.2 Dry the specimens for 57 min with  $107 \pm 2^\circ\text{C}$  ( $225 \pm 6^\circ\text{F}$ ) circulating air at  $1.74 \pm 0.29$  m/s ( $300 \pm 50$  ft/min).

8.2.3.3 Submerge the specimens for 10 min in boiling water.

### 8.3 Shear Testing of Cycled Wet Specimens:

8.3.1 Withdraw ten specimens from each set after exposure to 20, 40, 100, 200, 400, 800, and 1600 cycles.

8.3.2 Soak the specimens to be shear tested in  $23 \pm 2^\circ\text{C}$  ( $73.4 \pm 3.6^\circ\text{F}$ ) water until tested, this soak period not to exceed 3 days.

8.3.3 Test the wet specimens in tensile shear in accordance with 8.1.1. Record the results.

8.4 Withdraw two test specimens in the wet phase and two test specimens in the dry phase after 20, 100, and 400 cycles for moisture content determinations. Weigh the test specimens immediately or wrap them in plastic film if they cannot be weighed immediately. Moisture content may be determined by Method A of Test Methods D 4442 (see 7.1.1.1).

8.5 Miscellaneous specimens described in 7.1.3 may require modifications in the test method and cycles used.

## 9. Interpretation of Test Results

9.1 Plot the ultimate shear strength or percent wood failure, or both, versus number of cycles including data obtained from controls.

9.2 Using the graphs obtained from 9.1, rank all adhesives examined, process variables studied, and substrates evaluated.

## 10. Report

10.1 The report shall include, but not be limited to, the following:

10.2 Description of the materials used and preparation of the test specimens,

10.3 Aging of bonded specimens prior to test,

10.4 Indicate that tests were performed in accordance with this test method and list deviations, and

10.5 Prepare test results in graphical and tabular form.

10.6 Include dry phase and wet phase moisture content data as determined in 8.4.

## 11. Precision and Bias

11.1 Precision is made up of two parts: repeatability (within a laboratory) and reproducibility (between laboratories). Since only one automatic boil machine exists it is not possible to determine the reproducibility of this test method.

11.1.1 The repeatability is dependent, in large part, upon the individual test method used to determine the bond strength of

the laminate. For example, Test Method D 906 for Plywood Adhesives, or other test methods as appropriate for the specific test specimen or joint configuration.

11.2 This test method has no measure of bias since the strength of the laminate and wood failure are defined by the testing methods.

## 12. Keywords

12.1 adhesive; aging; boil test; multiple-cycle; wet; wood

*The American Society for Testing and Materials takes no position respecting the validity of any patent rights asserted in connection with any item mentioned in this standard. Users of this standard are expressly advised that determination of the validity of any such patent rights, and the risk of infringement of such rights, are entirely their own responsibility.*

*This standard is subject to revision at any time by the responsible technical committee and must be reviewed every five years and if not revised, either reapproved or withdrawn. Your comments are invited either for revision of this standard or for additional standards and should be addressed to ASTM Headquarters. Your comments will receive careful consideration at a meeting of the responsible technical committee, which you may attend. If you feel that your comments have not received a fair hearing you should make your views known to the ASTM Committee on Standards, at the address shown below.*

*This standard is copyrighted by ASTM, 100 Barr Harbor Drive, PO Box C700, West Conshohocken, PA 19428-2959, United States. Individual reprints (single or multiple copies) of this standard may be obtained by contacting ASTM at the above address or at 610-832-9585 (phone), 610-832-9555 (fax), or [service@astm.org](mailto:service@astm.org) (e-mail); or through the ASTM website ([www.astm.org](http://www.astm.org)).*