

NFPA 170 Standard on Fire Safety Symbols

1999 Edition



National Fire Protection Association, 1 Batterymarch Park, PO Box 9101, Quincy, MA 02269-9101
An International Codes and Standards Organization

Copyright ©
National Fire Protection Association, Inc.
One Batterymarch Park
Quincy, Massachusetts 02269

IMPORTANT NOTICE ABOUT THIS DOCUMENT

NFPA codes and standards, of which the document contained herein is one, are developed through a consensus standards development process approved by the American National Standards Institute. This process brings together volunteers representing varied viewpoints and interests to achieve consensus on fire and other safety issues. While the NFPA administers the process and establishes rules to promote fairness in the development of consensus, it does not independently test, evaluate, or verify the accuracy of any information or the soundness of any judgments contained in its codes and standards.

The NFPA disclaims liability for any personal injury, property or other damages of any nature whatsoever, whether special, indirect, consequential or compensatory, directly or indirectly resulting from the publication, use of, or reliance on this document. The NFPA also makes no guaranty or warranty as to the accuracy or completeness of any information published herein.

In issuing and making this document available, the NFPA is not undertaking to render professional or other services for or on behalf of any person or entity. Nor is the NFPA undertaking to perform any duty owed by any person or entity to someone else. Anyone using this document should rely on his or her own independent judgment or, as appropriate, seek the advice of a competent professional in determining the exercise of reasonable care in any given circumstances.

The NFPA has no power, nor does it undertake, to police or enforce compliance with the contents of this document. Nor does the NFPA list, certify, test or inspect products, designs, or installations for compliance with this document. Any certification or other statement of compliance with the requirements of this document shall not be attributable to the NFPA and is solely the responsibility of the certifier or maker of the statement.

NOTICES

All questions or other communications relating to this document and all requests for information on NFPA procedures governing its codes and standards development process, including information on the procedures for requesting Formal Interpretations, for proposing Tentative Interim Amendments, and for proposing revisions to NFPA documents during regular revision cycles, should be sent to NFPA headquarters, addressed to the attention of the Secretary, Standards Council, National Fire Protection Association, 1 Batterymarch Park, P.O. Box 9101, Quincy, MA 02269-9101.

Users of this document should be aware that this document may be amended from time to time through the issuance of Tentative Interim Amendments, and that an official NFPA document at any point in time consists of the current edition of the document together with any Tentative Interim Amendments then in effect. In order to determine whether this document is the current edition and whether it has been amended through the issuance of Tentative Interim Amendments, consult appropriate NFPA publications such as the *National Fire Codes*[®] Subscription Service, visit the NFPA website at www.nfpa.org, or contact the NFPA at the address listed above.

A statement, written or oral, that is not processed in accordance with Section 16 of the Regulations Governing Committee Projects shall not be considered the official position of NFPA or any of its Committees and shall not be considered to be, nor be relied upon as, a Formal Interpretation.

The NFPA does not take any position with respect to the validity of any patent rights asserted in connection with any items which are mentioned in or are the subject of this document, and the NFPA disclaims liability of the infringement of any patent resulting from the use of or reliance on this document. Users of this document are expressly advised that determination of the validity of any such patent rights, and the risk of infringement of such rights, is entirely their own responsibility.

Users of this document should consult applicable federal, state, and local laws and regulations. NFPA does not, by the publication of this document, intend to urge action that is not in compliance with applicable laws, and this document may not be construed as doing so.

Licensing Policy

This document is copyrighted by the National Fire Protection Association (NFPA). By making this document available for use and adoption by public authorities and others, the NFPA does not waive any rights in copyright to this document.

1. Adoption by Reference – Public authorities and others are urged to reference this document in laws, ordinances, regulations, administrative orders, or similar instruments. Any deletions, additions, and changes desired by the adopting authority must be noted separately. Those using this method are requested to notify the NFPA (Attention: Secretary, Standards Council) in writing of such use. The term “adoption by reference” means the citing of title and publishing information only.

2. Adoption by Transcription – **A.** Public authorities with lawmaking or rule-making powers only, upon written notice to the NFPA (Attention: Secretary, Standards Council), will be granted a royalty-free license to print and republish this document in whole or in part, with changes and additions, if any, noted separately, in laws, ordinances, regulations, administrative orders, or similar instruments having the force of law, provided that: (1) due notice of NFPA’s copyright is contained in each law and in each copy thereof; and (2) that such printing and republication is limited to numbers sufficient to satisfy the jurisdiction’s lawmaking or rule-making process. **B.** Once this NFPA Code or Standard has been adopted into law, all printings of this document by public authorities with lawmaking or rule-making powers or any other persons desiring to reproduce this document or its contents as adopted by the jurisdiction in whole or in part, in any form, upon written request to NFPA (Attention: Secretary, Standards Council), will be granted a nonexclusive license to print, republish, and vend this document in whole or in part, with changes and additions, if any, noted separately, provided that due notice of NFPA’s copyright is contained in each copy. Such license shall be granted only upon agreement to pay NFPA a royalty. This royalty is required to provide funds for the research and development necessary to continue the work of NFPA and its volunteers in continually updating and revising NFPA standards. Under certain circumstances, public authorities with lawmaking or rule-making powers may apply for and may receive a special royalty where the public interest will be served thereby.

3. Scope of License Grant – The terms and conditions set forth above do not extend to the index of this document.

(For further explanation, see the Policy Concerning the Adoption, Printing, and Publication of NFPA Documents, which is available upon request from the NFPA.)

Copyright © 1999 NFPA, All Rights Reserved

NFPA 170

Standard for

Fire Safety Symbols

1999 Edition

This edition of NFPA 170, *Standard for Fire Safety Symbols*, was prepared by the Technical Committee on Fire Safety Symbols and acted on by the National Fire Protection Association, Inc., at its May Meeting held May 17–20, 1999, in Baltimore, MD. It was issued by the Standards Council on July 22, 1999, with an effective date of August 13, 1999, and supersedes all previous editions.

Changes other than editorial are indicated by a vertical rule in the margin of the pages on which they appear. These lines are included as an aid to the user in identifying changes from the previous edition.

This edition of NFPA 170 was approved as an American National Standard on August 13, 1999.

Origin and Development of NFPA 170

The 1994 edition of NFPA 170 represented the completion of an effort to combine four previously separate documents that covered fire safety symbols for different purposes. These documents included the following:

NFPA 171, *Public Firesafety Symbols*

NFPA 172, *Fire Protection Symbols for Architectural and Engineering Drawings*

NFPA 174, *Fire Protection Symbols for Risk Analysis Diagrams*

NFPA 178, *Symbols for Fire Fighting Operations*.

The Technical Committee on Fire Safety Symbols believes that placing all fire safety symbols in one document will make it easier for users of symbols to find the one(s) most appropriate for their application. It will also eliminate duplication between these and eventually other NFPA documents.

The first edition of NFPA 170 placed these four documents in one document but did not combine them, except for definitions that were in each document.

For the second edition of NFPA 170, the Technical Committee on Fire Safety Symbols completely restructured the text into a logical and cohesive arrangement. The duplication of symbols that occurred during the aforementioned consolidation of documents was eliminated. New symbols added included those for *campfire prohibitions*, *smoke barriers*, *illuminated exit signs*, and *belowground tanks*.

For the third edition of NFPA 170, changes included the following:

- Upgrading recommendations on *pre-incident planning* to requirements (new Chapter 6)
- Adding new symbols for *pull station*, *area of refuge*, and *cooking prohibition*
- Clarifying the symbols for *smoke detectors*, *battery-powered emergency lights*, and *fire service/emergency telephone station*
- Recognizing the phaseout of halon now taking place, and the introduction of *clean agents*

The fourth edition further recognizes the introduction of clean agents by adding new symbols for *clean agent* and *water mist systems*. A new appendix (Appendix C) was added to include symbols that can be used for life safety planning.

Technical Committee on Fire Safety Symbols

Thomas R. Wood, *Chair*

Boca Raton Fire Rescue Services, FL [E]

Phillip A. Brown, American Fire Sprinkler Assn., Inc., TX [U]

Randal G. Brown, Randal Brown & Assoc., Ltd, Canada [U]

Lydia A. Butterworth, Smithsonian Institution, DC [E]

Randall S. Chaney, Wausau HPR Engr, CA [I]

Scott D. Corrin, University of California-Riverside, CA [SE]

David C. Cox, Fire Safety Displays Co., MI [M]

William P. MacDonald, New York Power Authority, NY [U]

James M. Mundy, Jr., Siemens Cerberus Division, NY [U]
Rep. Automatic Fire Alarm Assn., Inc.

Edward P. Quinn Jr., General Accident Insurance, NY [I]

George R. Riggs, Engineered Fire Systems, Inc., AK [IM]
Rep. Fire Suppression Systems Assn.

Brad Schiffer, Brad Schiffer/Taxis, Inc., FL [SE]

John Stofa, Simplex Time Recorder, VT [M]

James J. Vorce, Johnson Controls Inc., M14, WI [U]

Harry J. Walsh, Pennsylvania Lumbermens Mutual Insurance Co., PA [I]

Derik White, The CAD Zone, OR [SE]

David R. Hague, NFPA Staff Liaison

This list represents the membership at the time the Committee was balloted on the text of this edition. Since that time, changes in the membership may have occurred. A key to classifications can be found at the back of this document.

NOTE: Membership on a committee shall not in and of itself constitute an endorsement of the Association or any document developed by the committee on which the member serves.

Committee Scope: This Committee shall have primary responsibility for documents on fire safety symbols including those for building design plans, investigation diagrams, maps, and for public fire safety. It shall coordinate its work with NFPA technical committees and other groups dealing with subjects to which fire safety symbols apply.

Contents

<p>Chapter 1 General..... 170- 4</p> <p> 1-1 Scope 170- 4</p> <p> 1-2 Purpose 170- 4</p> <p> 1-3 Units 170- 4</p> <p>Chapter 2 Definitions 170- 4</p> <p> 2-1 Official NFPA Definitions 170- 4</p> <p> 2-2 Definitions of Terms Used in the Standard 170- 4</p> <p>Chapter 3 Symbols for General Use 170- 4</p> <p> 3-1 Introduction 170- 4</p> <p> 3-2 Symbols for General Use 170- 5</p> <p>Chapter 4 Symbols for Use by the Fire Service..... 170- 7</p> <p> 4-1 Introduction 170- 7</p> <p> 4-2 Symbols for Use by the Fire Service 170- 7</p> <p>Chapter 5 Symbols for Use in Architectural and Engineering Drawings and Insurance Diagrams 170- 9</p> <p> 5-1 Introduction 170- 9</p> <p> 5-2 Symbols for Site Features 170- 9</p> <p> 5-3 Symbols for Building Construction 170- 9</p> <p> 5-4 Water Supply and Distribution Symbols 170-11</p> <p> 5-5 Symbols for Control Panels 170-12</p> <p> 5-6 Symbols Related to Means of Egress 170-13</p> <p> 5-7 Symbols for Fire Alarms, Detection, and Related Equipment 170-13</p> <p> 5-8 Symbols for Fire Extinguishing Systems 170-15</p>	<p> 5-9 Symbols for Portable Fire Extinguishers ... 170-17</p> <p> 5-10 Symbols for Fire-Fighting Equipment 170-17</p> <p> 5-11 Symbols for Smoke/Pressurization Control 170-17</p> <p> 5-12 Miscellaneous Symbols 170-18</p> <p>Chapter 6 Symbols for Use in Pre-Incident Planning Sketches..... 170-18</p> <p> 6-1 Introduction 170-18</p> <p> 6-2 Access Features, Assessment Features, Ventilation Features, and Utility Shutoffs 170-19</p> <p> 6-3 Detection/Extinguishing Equipment 170-19</p> <p> 6-4 Water Flow Control Valves and Water Sources 170-20</p> <p> 6-5 Equipment Rooms 170-20</p> <p> 6-6 Identification of Hazardous Materials 170-21</p> <p>Chapter 7 Referenced Publications 170-21</p> <p>Appendix A Explanatory Material..... 170-21</p> <p>Appendix B Additional Explanatory Information on Chapters 1 through 5 170-24</p> <p>Appendix C Symbols for Life Safety Planning 170-28</p> <p>Appendix D Referenced Publications 170-30</p> <p>Appendix E Informatory Publications 170-30</p> <p>Index 170-32</p>
---	--

NFPA 170

Standard for Fire Safety Symbols

1999 Edition

NOTICE: An asterisk (*) following the number or letter designating a paragraph indicates that explanatory material on the paragraph can be found in Appendix A.

Information on referenced publications can be found in Chapter 7 and Appendix D.

Chapter 1 General

1-1 Scope. This standard presents symbols used for fire safety and associated hazards.

1-2 Purpose. The purpose of this standard is to standardize the symbols used in representing fire and associated hazards.

1-3 Units. Metric units of measurement used in this standard shall be in accordance with the International System of Units (SI). One unit (liter), outside of but recognized by SI, is commonly used in international fire protection. For conversion factors, see Table 1-3.

Table 1-3 Metric Conversion Factors

Name of Unit	Unit Symbol	Conversion Factor
Liter	L	1 gal = 3.785 L
Cubic decimeter	dm ³	1 gal = 3.785 dm ³
Pascal	Pa	1 psi = 6894.757 Pa
Meter	m	1 ft = 0.3048 m
Millimeter	mm	1 in. = 25.4 mm

Chapter 2 Definitions

2-1 Official NFPA Definitions.

Approved.* Acceptable to the authority having jurisdiction.

Authority Having Jurisdiction.* The organization, office, or individual responsible for approving equipment, materials, an installation, or a procedure.

Labeled. Equipment or materials to which has been attached a label, symbol, or other identifying mark of an organization that is acceptable to the authority having jurisdiction and concerned with product evaluation, that maintains periodic inspection of production of labeled equipment or materials, and by whose labeling the manufacturer indicates compliance with appropriate standards or performance in a specified manner.

Listed.* Equipment, materials, or services included in a list published by an organization that is acceptable to the author-

ity having jurisdiction and concerned with evaluation of products or services, that maintains periodic inspection of production of listed equipment or materials or periodic evaluation of services, and whose listing states that either the equipment, material, or service meets appropriate designated standards or has been tested and found suitable for a specified purpose.

Shall. Indicates a mandatory requirement.

Should. Indicates a recommendation or that which is advised but not required.

2-2 Definitions of Terms Used in the Standard.

Pre-Incident Planning A written document resulting from the gathering of general and detailed information/data to be used by public emergency response agencies and private industry for determining the response to reasonable anticipated emergency incidents at a specific facility.

Referent.* An object or concept (message) represented by a symbol.

Self-Luminous. A type of sign that is self-energized with respect to luminosity and requires no external power source.

Supplementary Indicators.* Figures, numbers, subscripts, or letter abbreviations used to enhance the effectiveness of symbols.

Symbol.* A graphic representation of a referent.

Chapter 3 Symbols for General Use

3-1 Introduction.

3-1.1 Scope. This chapter presents general referents and symbols for fire prevention and visual alerting for fire and related life safety emergencies.

3-1.2 Purpose.

3-1.2.1 The purpose of this chapter is to provide uniform fire safety symbols to improve communication wherever signs and symbols are employed to provide fire safety information.

3-1.2.2 This chapter provides uniformity in the selection of symbols that are designed to assist in locating exits, fire safety alerting equipment, and safe areas.

3-1.2.3* The fundamental imagery for symbols, as well as their background color and shape, is designated in this chapter.

3-1.2.4* This chapter does not specify viewing distance, size, or optimal combinations of symbols, words, or other presentations.

3-1.3* Symbol Presentation.

3-1.3.1 The orientation for prohibition symbols shall not be altered from that shown in this chapter.

3-1.3.2 The symbol background shape shall be square.

*Exception:** For prohibition symbols, a circle and diagonal slash (at 45 degrees from upper left to lower right) shall be used.

3-1.3.3 Symbol Color. The symbol color shall meet the requirements of ANSI Z535.1, *Safety Color Code*.

3-2* Symbols for General Use.

3-2.1 Emergency Exit.



Characteristics: Square field; background green; door opening white; image in green or black.

Application: The identification and location of an emergency exit.

Example: The location of exit for use in a fire emergency.

3-2.2 Emergency Exit Route.



Characteristics: Square field; background green; door opening white; image in green or black.

Application: The identification and location of a route to be used in an emergency.

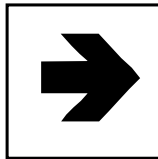

Characteristics: For arrows: square field; background white; arrow in green or black.

Example: The direction to a fire exit.

3-2.3 Accessible Emergency Exit.



Characteristics: Square field; background green; door opening white; image in green or black.

Application: The identification of an emergency exit that is accessible to disabled users, as specified by ANSI A117.1, *Specifications for Making Buildings and Facilities Accessible to and Usable by Physically Handicapped People*.



Characteristics: International symbol of accessibility per ANSI A117.1, *Specifications for Making Buildings and Facilities Accessible to and Usable by Physically Handicapped People*.

Example: The location of a fire exit that is accessible to disabled users.

3-2.4 Accessible Emergency Exit Route.



Characteristics: Square field; background green; door opening white; image in green or black.

Application: The identification of a route that leads to an emergency exit that is accessible to disabled users.



Characteristics: International symbol of accessibility per ANSI A117.1, *Specifications for Making Buildings and Facilities Accessible to and Usable by Physically Handicapped People*.

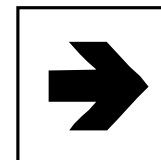

Characteristics: For arrows: square field; background white; arrow in green or black.

Example: The location of the route toward a fire exit that is accessible to disabled users.

3-2.5 Not an Exit.



Characteristics: Square field; background white; door frame green; door opening white; image in green or black; red circle and diagonal slash.

Application: The identification of doors that do NOT lead to an exit.

Example: The location of an interior door such as one leading to a closet, interior courtyard, or basement.

3-2.6 Use Stairs in Case of Fire.



Characteristics: Square field; red flame; black figure; white background.

Application: An instruction to the user to use stairs (downward egress) in case of fire.

Example: The identification that stairs are to be used in case of fire.

3-2.7 Use Stairs in Case of Fire.



Characteristics: Square field; red flame; black figure; white background.

Application: An instruction to the user to use stairs (upward egress) in case of fire.

Example: The identification that stairs are to be used in case of fire.

3-2.8 Do Not Use Elevator in Case of Fire.



Characteristics: Square field; red flame; black figures; white background; red circle and slash.

Application: An instruction not to use elevators in case of fire.

Example: Posted near elevator call button.

3-2.9 No Smoking.



Characteristics: Circular field; red circle and slash; black image; white background.

Application: The identification of areas in which smoking is prohibited.

Example: The identification of areas, such as those for flammable liquid storage, where smoking could lead to fire or explosion.

3-2.10 No Campfires.



Characteristics: Circular field; red circle and slash; black image; white background.

Application: The identification of areas, such as municipal parks, where campfires are not permitted.

3-2.11 Manually Activated Alarm Initiating Device (Manual Pull Station).

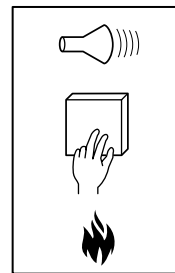

Characteristics: Rectangular field; white background; red flame; black hand; red box; red horn; red wave.

Application: An instruction to actuate an alarm initiating device in a fire emergency.

Example: Posted above a manually activated initiating device.

3-2.12 No Cooking.



Characteristics: Square field; white background; red flame; black pot and steam; red circle and slash.

Application: An instruction not to cook food in an area.

Example: Posted inside a guest room in a hotel or a student room in a college dormitory.

3-2.13 Area of Refuge.



Characteristics: Square field; white background; red flame.

Application: The identification of an area of refuge.

Example: A designated area of refuge to be used in a fire emergency.

Chapter 4 Symbols for Use by the Fire Service

4-1 Introduction.

4-1.1 Scope. This chapter presents standard referents and symbols that shall be used for visually alerting fire fighters and other emergency responders during fire and related emergencies.

4-1.2 Purpose.

4-1.2.1 The purpose of this chapter is to present uniform fire-fighting symbols in order to improve communication wherever symbology is employed in order to provide information to fire fighters and other emergency responders.

4-1.2.2 This chapter provides uniformity in the selection of symbols that are intended to assist fire fighters in locating utilities and fire-fighting equipment.

4-1.2.3* Fundamental shapes of symbols, as well as the background color and shape, are designated in this chapter.

4-1.3* Symbol Presentation.

4-1.3.1* Symbol Shapes. The shape of symbols shall be as illustrated in Section 4-2.

4-1.3.2 Symbol Background.

4-1.3.2.1 The symbol background shall be square.

4-1.3.2.2 The symbol background color shall be red, white, or blue as designated and shall meet the requirements of ANSI Z535.1, *Safety Color Code*, for safety red, white, or blue.

4-1.3.3 Symbol Color. The symbol color shall be safety white or blue and shall meet the requirements of ANSI Z535.1, *Safety Color Code*, for safety white or blue.

4-1.3.4 Symbol Orientation. Symbol orientation shall not be altered from that shown in this chapter.

4-2* Symbols for Use by the Fire Service.

4-2.1 Fire Department Automatic Sprinkler Connection — Siamese.

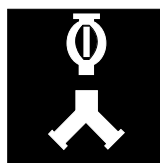

Characteristics: Square field; red background; white symbol.

Application: The identification and location of a fire department automatic sprinkler connection.

Examples:

- The location of siamese automatic sprinkler connections on buildings.
- The location of siamese freestanding automatic sprinkler connections.

4-2.2 Fire Department Automatic Sprinkler Connection — Single.

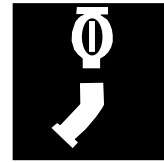

Characteristics: Square field; red background; white symbol.

Application: The identification and location of a fire department automatic sprinkler connection.

Examples:

- The location of a single automatic sprinkler connection on buildings.
- The location of a single freestanding automatic sprinkler connection.

4-2.3 Fire Department Standpipe Connection.

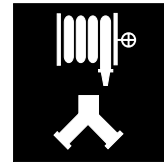

Characteristics: Square field; red background; white symbol.

Application: The identification and location of a fire department standpipe connection.

Examples:

- The location of standpipe connections on buildings and structures.
- The location of freestanding standpipe connections.

4-2.4 Fire Department Combined Automatic Sprinkler/Standpipe Connection.

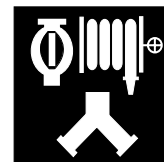

Characteristics: Square field; red background; white symbol.

Application: The identification and location of a fire department combined automatic sprinkler/standpipe connection.

Examples:

- The location of combined sprinkler/standpipe connections on buildings.
- The location of freestanding combined sprinkler/standpipe connections.

4-2.5* Fire Hydrant (All Types).

Characteristics: Square field; red background; white symbol.

Application: The identification and location of a fire hydrant.

Example: The location of fire hydrants, wall hydrants, underground hydrants, or other fire-fighting water supplies.

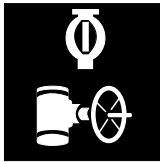
4-2.6 Automatic Sprinkler Control Valve.

Characteristics: Square field; red background; white symbol.

Application: The identification and location of an automatic sprinkler control valve.

Examples:

- The location of control valves for automatic sprinkler systems.
- On doors of rooms containing control valves.

4-2.7 Electric Panel or Electric Shutoff.

Characteristics: Square field; blue background; white symbol.

Application: The identification and location of an electrical panel or other electric shutoff device.

Example: The location of electric panels or other electric control devices that can be located in basements or mechanical rooms.

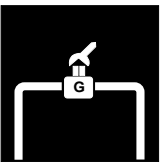
4-2.8 Gas Shutoff Valve.

Characteristics: Square field; red background; white symbol; red letter G.

Application: The location of a gas shutoff valve.

Examples:

- The location of gas shutoff valves.
- On doors of rooms containing gas shutoff valves.

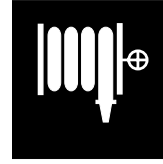
4-2.9 Fire-Fighting Hose or Standpipe Outlet.

Characteristics: Square field; red background; white symbol.

Application: The location of a fire-fighting hose or a standpipe outlet.

Examples:

- The location of interior fire-fighting hose stations and standpipe outlets in buildings and structures.
- The location on bridges or elevated highways.

4-2.10 Fire Extinguisher.

Characteristics: Square field; red background; white symbol.

Application: The location of a fire extinguisher.

Example: The location of fire extinguishers in buildings and exterior locations.

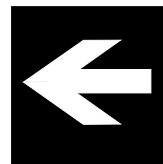
4-2.11 Directional Arrow.

Characteristics: Square field; background (red or blue) to correspond to accompanying sign; or white symbol.

Application: Direction to the location of fire-fighting equipment or utility. Always used in conjunction with, and adjacent to, another symbol indicating the particular equipment or utility.

4-2.12 Diagonal Directional Arrow.

Characteristics: Square field; background (red or blue) to correspond to accompanying sign; white symbol.

Application: Direction to the location of fire-fighting equipment or utility. Always used in conjunction with, and adjacent to, another symbol indicating the particular equipment or utility.

4-2.13 Child Care Center.



Characteristics: Square field; blue infant and hands; white background.

Application: The identification and location of child care centers.

Examples:

- On the door opening into child care centers.
- At a fire department command or access point indicating presence and location of child care centers.

Chapter 5 Symbols for Use in Architectural and Engineering Drawings and Insurance Diagramms

5-1* Introduction.

5-1.1 **Scope.** This chapter presents symbols that shall be used in drawings and diagrams.

5-1.2* **Purpose.** The purpose of this chapter is to provide uniformity in the use of fire safety and related symbols in the preparation of drawings and diagrams.

5-1.3* **Application.** The symbols in this chapter are intended for, but not limited to, architectural and engineering drawings, fire detection and suppression drawings, and fire risk and/or loss analysis diagrams.

5-1.4* **Symbol Presentation.**

5-1.4.1* **Symbol Shapes.** The shape of symbols shall be as illustrated in Sections 5-2 through 5-12.

5-1.4.2 **Screened Lines.** Screened lines in the chapter shall not be considered part of the symbol, but shall be used to represent the piping, wiring, or mounting surface associated with the symbol.

5-1.4.3 **Symbol Scale.** All scales for symbols on any one drawing shall be the same relative size.

5-1.4.4* **Symbol Orientation.** Symbols shall be oriented to the walls, piping, electrical lines, and so forth to which they are attached.

5-2 Symbols for Site Features.

5-2.1 Buildings.

5-2.1.1 The exterior walls of buildings shall be outlined in single thickness lines if other than fire rated and double thickness lines if fire rated.

5-2.1.2* The perimeter of canopies, loading docks, and other open-walled structures shall be shown by broken lines.

5-2.2 **Railroad Tracks.** Railroad tracks shall be shown by a single line with cross dashes.



5-2.3* **Streets.** Streets shall be shown.

5-2.4* **Bodies of Water.** Rivers, lakes, and so forth shall be outlined.

5-2.5 Fences.

5-2.5.1 Fences shall be shown by lines with x's evenly spaced.

5-2.5.2* Gates shall be shown.

5-2.6 **Property Lines.** The notation given below shall indicate property lines.



5-2.7 **Fire Department Access.** The symbol for fire department access shall be as follows:



5-2.8 **Other Site Features.** For other fire protection site features, see Section 5-4.

5-3 Symbols for Building Construction.

5-3.1* **Types of Building Construction.** Types of construction shall be shown narratively.

5-3.2* **Height.** Height shall be shown to indicate number of stories above ground, number of stories below ground, and height from grade to eaves.

5-3.3 Symbols for Walls and Parapets.

5-3.3.1* Wall.



Comments: Basic shape.

(1) Smoke barrier

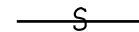

(2) 1/2-hour fire-rated



(3) 1/2-hour fire-rated/smoke barrier



(4) 3/4-hour fire-rated



(5) 3/4-hour fire-rated/smoke barrier



(6) 1-hour fire-rated



(7) 1-hour fire-rated/smoke barrier



(8) 2-hour fire-rated



(9) 2-hour fire-rated/smoke barrier



(10) 3-hour fire-rated



(11) 3-hour fire-rated/smoke barrier



(12) 4-hour fire-rated



(13) 4-hour fire-rated/smoke barrier



5-3.3.2* Parapet.



Comments: One cross for each 6-in. (150-mm) parapet extends above roof. (Shown is plan view of symbol.)

5-3.4 Symbols for Floor Openings, Wall Openings, Roof Openings, and Their Protection.

5-3.4.1 Opening in Wall.

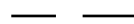

5-3.4.2 Rated Fire Door in Wall (less than 3 hours).



5-3.4.3 Fire Door in Wall (3-hour rated).



5-3.4.4 Elevator in Combustible Shaft.



5-3.4.5 Elevator in Noncombustible Shaft.



5-3.4.6 Open Hoistway.



5-3.4.7 Escalator.



5-3.4.8 Stairs in Combustible Shaft.



5-3.4.9 Stairs in Fire-Rated Shaft.



5-3.4.10 Stairs in Open Shaft.



5-3.4.11 Skylight.



5-3.5* Special Symbols for Cross Sections. The following symbols shall be used to indicate features of cross sections. It is recognized that descriptive notes often are required.

5-3.5.1 Roof, Floor Assemblies.

5-3.5.1.1 Fire-Resistive Floor or Roof.



5-3.5.1.2 Wood Joisted Floor or Roof.

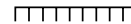

5-3.5.1.3 Other Floors or Roofs.

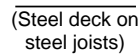

Comments: Note construction.

5-3.5.1.4 Floor/Ceiling or Roof/Ceiling Assembly.

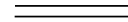

Comments: Details indicated, as necessary.

5-3.5.1.5 Floor on Ground.



5-3.5.1.6 Truss Roof.



Comments: Note construction.

5-3.6 Miscellaneous Features. A number of features related to fire protection that do not fall under 5-3.1 through 5-3.5 are given below.

5-3.6.1 Boiler.



5-3.6.2 Chimney.



Comments: Describe height and construction.

5-3.6.3 Fire Escape.



5-3.6.4 Tank, Aboveground.

5-3.6.4.1 Horizontal.



Comments: Indicate type, dimensions, construction, capacity, pressurization, and content.

5-3.6.4.2 Vertical.



Comments: Indicate type, dimensions, construction, capacity, pressurization, and content.

5-3.6.5 Tank, Belowground.



Comments: Indicate type, dimensions, construction, capacity, pressurization, and content.

5-4 Water Supply and Distribution Symbols.

5-4.1 Mains, Pipe.

5-4.1.1 Public Water Main.



Comments: Indicate pipe size and material.

5-4.1.2 Private Water Main.



Comments: Indicate pipe size and material.

5-4.1.3 Water Main Under Building.

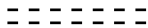

Comments: Indicate pipe size and material.

5-4.1.4 Suction Pipe.



Comments: Indicate pipe size and material.

5-4.1.5 Thrust Block.

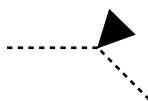

5-4.1.6 Riser.



5-4.2 Valves (General).



Comments: Basic shape. Indicate valve size.

5-4.2.1 Valve in Pit.



Comments: Indicate valve size.

5-4.2.2 Post-Indicator Valve.



Comments: Indicate valve size.

5-4.2.3 Key-Operated Valve.



Comments: Indicate valve size.

5-4.2.4 OS & Y Valve (Outside Screw and Yoke, Rising Stem).



Comments: Indicate valve size.

5-4.2.5 Indicating Butterfly Valve.



Comments: Indicate valve size.

5-4.2.6 Nonindicating Valve (Nonrising-Stem Valve).

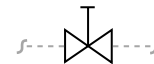

Comments: Indicate valve size.

5-4.2.7 Check Valve.



Comments: Basic shape. Indicate valve size, direction of flow.

5-4.2.8 Backflow Preventer — Double Check Type.



Comments: Also referred to as a double check valve assembly.

5-4.2.9 Backflow Preventer — Reduced Pressure Zone (RPZ) Type.

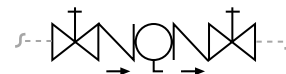

5-4.2.10 Pressure Regulating Valve.



5-4.2.11 Pressure Relief Valve.

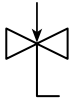

5-4.2.12 Float Valve.



5-4.3 Meter.



Comments: Indicate type.

5-4.4* Hydrants.

5-4.4.1 Private Hydrant, One Hose Outlet.



Comments: Indicate size, type of thread, or connection.

5-4.4.2 Public Hydrant, Two Hose Outlets.



Comments: Indicate size, type of thread, or connection.

5-4.4.3 Public Hydrant, Two Hose Outlets, and Pumper Connection.



Comments: Indicate size, type of thread, or connection.

5-4.4.4 Wall Hydrant, Two Hose Outlets.



Comments: Indicate size, type of thread, or connection.

5-4.4.5 Private Housed Hydrant, Two Hose Outlets.



Comments: Indicate size, type of thread, or connection.

5-4.5 Fire Department Connections.

5-4.5.1 Siamese Fire Department Connection.

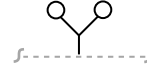

Comments: Specify type, size, and angle.

5-4.5.2 Freestanding Siamese Fire Department Connection.



Comments: Sidewalk or pit type, specify size.

5-4.5.3 Single Fire Department Connection.

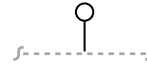

Comments: Specify type, size, thread, and angle.

5-4.6 Fire Pumps.

5-4.6.1 Fire Pump with Drives.



5-4.6.2 Freestanding Test Header.



Comments: Freestanding. Specify number and sizes of outlets.

5-4.6.3 Wall-Mounted Test Header.



Comments: Wall. Specify number and sizes of outlets.

5-4.7 Screen/Strainer.

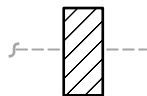

5-5 Symbols for Control Panels.

5-5.1 Control Panel.



Comments: Basic shape.

(1) Fire Alarm Control Panel



(2) Fire System Annunciator



(3) Fire Alarm Transponder or Transmitter



(4) Elevator Status/Recall



(5) Fire Alarm Communicator



(6) Halon Control Panel



(7) Control panel for heating, ventilation, air-conditioning, exhaust stairwell pressurization, or similar equipment



5-6 Symbols Related to Means of Egress.

5-6.1 Emergency Light, Battery-Powered.

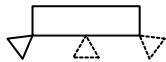

Comments: Number of lamps on unit to be indicated. Indicate whether light head(s) [lamp(s)] is remote from battery.

5-6.2 Illuminated Exit Sign, Single Face.



Comments: Indicate direction of flow for the face.

5-6.3 Illuminated Exit Sign, Double Face.



Comments: Indicate direction of flow for each face.

5-6.4 Combined Battery-Powered Emergency Light and Illuminated Exit Sign.

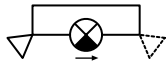

Comments: Number of lamps on unit to be indicated. Indicate whether light head(s) [lamp(s)] is remote from battery. Indicate direction of flow for the face.

5-7 Symbols for Fire Alarms, Detection, and Related Equipment.

5-7.1 Signal Initiating Devices and Switches.

5-7.1.1* Manual Station.



Comments: Basic shape.

(1) Halon



(2) Carbon Dioxide



(3) Dry Chemical



(4) Foam



(5) Wet Chemical



(6) Pull Station



(7) *Clean Agent

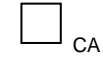

(8) Water Mist



(9) Deluge Sprinkler



5-7.1.1.1* Fire Service or Emergency Telephone Station.



Comments: Basic shape.

(1) Accessible



(2) Jack



(3) Handset



5-7.1.1.2 Abort Switch.



Comments: Basic shape.

(1) Halon



(2) Carbon Dioxide



(3) Dry Chemical



(4) Foam



(5) Wet Chemical



(6) Clean Agent



(7) Water Mist



(8) Deluge Sprinkler



5-7.1.2 Automatic Detection and Supervisory Devices.



Comments: Basic shape.

5-7.1.2.1* Heat Detector (Thermal Detector).



Comments: Symbol orientation not to be changed.

(1) Combination — Rate of Rise and Fixed Temperature



(2) Rate Compensation



(3) Fixed Temperature



(4) Rate of Rise only



(5) Line-Type Detector (Heat-Sensitive Cable)



5-7.1.2.2 Smoke Detector.



Comments: Symbol orientation not to be changed.

(1) Photoelectric Products of Combustion Detector



(2) Ionization Products of Combustion Detector



(3) Beam Transmitter



(4) Beam Receiver



(5) Air Sampling



5-7.1.2.3* Smoke Detector for Duct.



5-7.1.2.4* Gas Detector.



5-7.1.2.5 Flame Detector.



Comments: Indicate ultraviolet (UV), infrared (IR), ultraviolet/infrared (UV/IR), or visible radiation-type detectors. Symbol orientation not to be changed.

5-7.1.2.6 Flow Detector/Switch.

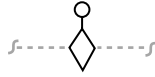

5-7.1.2.7 Pressure Detector/Switch.

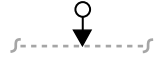

Comments: Specify type — water, low air, high air, and so forth. Symbol orientation not to be changed.

5-7.1.2.8 Level Detector/Switch.

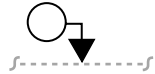

Comments: Symbol orientation not to be changed.

5-7.1.2.9 Tamper Detector.

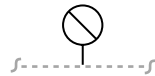

Comments: Alternate term — tamper switch.

5-7.1.2.10 Valve with Tamper Detector/Switch.

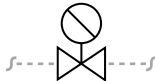

5-7.2 Indicating Appliances.

5-7.2.1 Speaker/Horn (Electric Horn).



(1) Mini-Horn



5-7.2.2 Bell (Gong).



5-7.2.3 Water Motor Alarm (Water Motor Gong).



Comments: Shield optional.

5-7.2.4 Horn with Light.

(1) Horn with light as separate assembly



(2) Horn with light as one assembly



5-7.2.5 Light (Lamp, Signal Light, Indicator Lamp, Strobe).



5-7.3 Related Equipment.

5-7.3.1 Door Holder.

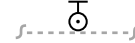

5-8* Symbols for Fire Extinguishing Systems.

5-8.1 Various Types of Fire Extinguishing Systems.

5-8.1.1 Water-Based Systems.

5-8.1.1.1 Wet Charged System.

(1) Automatically actuated



(2) Manually actuated



5-8.1.1.2 Dry System.

(1) Automatically actuated



(2) Manually actuated



5-8.1.1.3 Foam System.

(1) Automatically actuated



(2) Manually actuated



5-8.1.1.4 Water Mist Extinguishing System.

(1) Automatically actuated



(2) Manually actuated



5-8.1.2 Dry Chemical Systems.

5-8.1.2.1 For Liquid, Gas, and Electrical Fires.

(1) Automatically actuated



(2) Manually actuated



5-8.1.2.2 For Fires of All Types (Except Metals).

(1) Automatically actuated



(2) Manually actuated



5-8.1.3 Systems Utilizing a Gaseous Medium.

5-8.1.3.1 Carbon Dioxide System.

(1) Automatically actuated



(2) Manually actuated



5-8.1.3.2 Halon System or Clean Agent Extinguishing System.

(1) Automatically actuated



(2) Manually actuated



5-8.1.4 Supplementary Symbols.

5-8.1.4.1 Fully Sprinklered Space.



5-8.1.4.2 Partially Sprinklered Space.



5-8.1.4.3 Nonsprinklered Space.

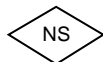

5-8.1.4.4 Water Spray System.



5-8.2* Symbols for Fire Sprinklers.

5-8.2.1 Upright Sprinkler.



5-8.2.2 Pendent Sprinkler.



Comments: Note “DP” on drawing and/or in specifications where dry pendent sprinklers are employed.

5-8.2.3 Upright Sprinkler; Nipped Up.



5-8.2.4 Pendent Sprinkler; on Drop Nipple.



Comments: Note “DP” on drawing and/or in specifications where dry pendent sprinklers are employed.

5-8.2.5 Sprinkler, with Guard.



Comments: Upright sprinkler head shown.

5-8.2.6 Sidewall Sprinkler.



5-8.2.7 Outside Sprinkler.



Comments: Specify type, orifice size. For example: Open sprinkler (window or cornice).

5-8.3* Symbols for Piping, Valves, Control Devices, and Hangers.

5-8.3.1 Sprinkler Piping and Branch Line.



Comments: Indicate pipe size.

5-8.3.2 Pipe Hanger.

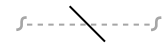

Comments: This symbol is a diagonal stroke imposed on the pipe that it supports.

5-8.3.3 Angle Valve (Angle Hose Valve).

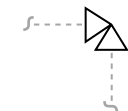

Comments: Indicate size, type, and other required data.

5-8.3.4 Check Valve (General). See symbol in 5-4.2.7.

5-8.3.5 Alarm Check Valve.

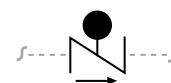

Comments: Specify size, direction of flow.

5-8.3.6 Dry Pipe Valve.

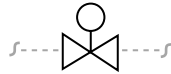

Comments: Specify size.

5-8.3.7 Dry Pipe Valve with Quick Opening Device (Accelerator or Exhauster).

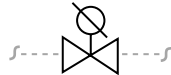

Comments: Specify size and type.

5-8.3.8 Deluge Valve.

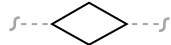

Comments: Specify size and type.

5-8.3.9 Preaction Valve.



Comments: Specify size and type.

5-9 Symbols for Portable Fire Extinguishers.

5-9.1 Portable Fire Extinguisher.



Comments: Basic shape.

5-9.2 Water Extinguisher.



5-9.3 Foam Extinguisher.



5-9.4 Dry Chemical Extinguishers.

5-9.4.1 For Liquid, Gas, or Electrical Fires.



Comments: BC-type.

5-9.4.2 For Fires of All Types (Except Metals).



Comments: ABC-type.

5-9.5 CO₂ Extinguishers.



5-9.6 Halon or Clean Agent Extinguishers.



5-9.7 Extinguisher for Metal Fires.



5-10 Symbols for Fire-Fighting Equipment.

5-10.1 Fire-Fighting Equipment.



Comments: Basic shape.

5-10.2 CO₂ Reel Station.



5-10.3 Dry Chemical Reel Station.



5-10.4 Foam Reel Station.



5-10.5 Hose Station, Dry Standpipe.



5-10.6 Hose Station, Charged Standpipe.



5-10.7 Monitor Nozzle, Dry.



Comments: Specify orifice size.

5-10.8 Monitor Nozzle, Charged.



Comments: Specify orifice size.

5-11 Symbols for Smoke/Pressurization Control.

5-11.1 Purge Controls.

5-11.1.1 Manual Control.



5-11.2 Fans.

Comments: Arrow indicates direction of flow.

5-11.2.1 General.



5-11.2.2 Duct.



5-11.2.3 Roof.



5-11.2.4 Wall.



5-11.3 Dampers.

5-11.3.1 Fire.

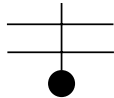

5-11.3.2 Smoke.

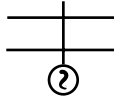

5-11.3.3 Fire/Smoke.

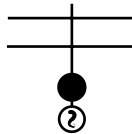

5-11.3.4 Barometric.



5-11.4 Pressurized Stairwell.



Comments: Orient as required for base or head injection.

5-11.5 Ventilation Openings.



Comments: Orient as required for intake or exhaust.

5-12 Miscellaneous Symbols.

5-12.1 Agent Storage Container.



Comments: Specify type of agent and mounting.

(1) Foam



(2) Halon



(3) Carbon Dioxide



(4) Clean Agent



(5) Dry Chemical



(6) Water Mist



5-12.2 Special Spray Nozzle.



Comments: Specify type, orifice, size, other required data (shown here on pipe).

5-12.3 Fusible Link.

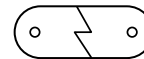

Comments: Specify degrees.

5-12.3.1* Fusible Link with Electrothermal Feature.

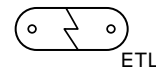

Comments: Specify degrees.

5-12.4 Solenoid Valve.



Chapter 6 Symbols for Use in Pre-Incident Planning Sketches

6-1 Introduction.

6-1.1 Scope. This chapter presents symbols that shall be used in pre-incident planning sketches.

6-1.2 Purpose. The purpose of this chapter is to provide uniformity in the use of fire safety and related symbols in the preparation of pre-incident planning sketches.

6-1.3 Application. The symbols in this chapter are provided to assist fire service or emergency response personnel who are responsible for preparing and using pre-incident planning sketches.

6-1.4* Symbol Shapes. The symbol shapes were chosen for their ease of reproduction through either freehand drawing or with the use of templates.

6-2* Access Features, Assessment Features, Ventilation Features, and Utility Shutoffs.



Comments: Basic shape.

6-2.1 Access Features.

6-2.1.1 Fire Department Access Point.



6-2.1.2 Fire Department Key Box.



6-2.1.3 Roof Access.



6-2.2 Assessment Features.

6-2.2.1 Fire Alarm Annunciator Panel.



6-2.2.2 Fire Alarm Reset Panel.



6-2.2.3 Fire Alarm Voice Communication Panel.



6-2.2.4 Smoke Control and Pressurization Panel.



6-2.2.5 Sprinkler System Water Flow Bell.



6-2.3 Ventilation Features.

6-2.3.1 Skylight.



6-2.3.2 Smoke Vent.



6-2.4 Utility Shutoffs.

6-2.4.1 Electric Shutoff.



6-2.4.2 Domestic Water Shutoff.



6-2.4.3 Gas Shutoff.



6-2.4.3.1 Specific Variations.

6-2.4.3.1.1 LP-Gas Shutoff.



6-2.4.3.1.2 Natural Gas Shutoff.



6-2.4.3.1.3 Compressed Natural Gas Shutoff.



6-3 Detection/Extinguishing Equipment.

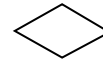

Comments: Basic shape.

6-3.1 Duct Detector.



6-3.2 Heat Detector.

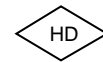

6-3.3 Smoke Detector.

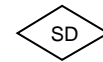

6-3.4 Flow Switch (Water).



6-3.5 Manual Pull Station.



6-3.6 Tamper Switch.



6-3.7 Halon System.



6-3.8 Dry Chemical System.



6-3.9 CO₂ System.



6-3.10 Wet Chemical System.



6-3.11 Foam System.



6-3.12 Clean Agent System.



6-3.13 Beam Smoke Detector.



6-4 Water Flow Control Valves and Water Sources.



Comments: Basic shape.

6-4.1 Post-Indicator Valve.



6-4.2 Riser Valve.



6-4.3 Sprinkler Zone Valve.



6-4.4 Hose Cabinet or Connection.



6-4.5 Wall Hydrant.



6-4.6 Test Header (Fire Pump).



6-4.7 Inspector's Test Connection.



6-4.8 Fire Hydrant.



6-4.9 Fire Department Connection.



6-4.10 Drafting Site.



6-4.11 Water Tank.



6-5 Equipment Rooms.



Comments: Basic shape.

6-5.1 Air-Conditioning Equipment Room.



Comments: AHUs = Air Handling Units

6-5.2 Elevator Equipment Room.



6-5.3 Emergency Generator Room.



6-5.4 Fire Pump Room.



6-5.5 Telephone Equipment Room.**6-5.6 Boiler Room.****6-5.7 Electrical/Transformer Room.**

6-6* Identification of Hazardous Materials. NFPA 704, *Standard System for the Identification of the Hazards of Materials for Emergency Response*, shall be permitted to be used to identify the location of hazardous materials within a structure.

Chapter 7 Referenced Publications

7-1 The following documents or portions thereof are referenced within this standard as mandatory requirements and shall be considered part of the requirements of this standard. The edition indicated for each referenced mandatory document is the current edition as of the date of the NFPA issuance of this standard. Some of these mandatory documents might also be referenced in this standard for specific informational purposes and, therefore, are also listed in Appendix D.

7-1.1 NFPA Publication. National Fire Protection Association, 1 Batterymarch Park, P.O. Box 9101, Quincy, MA 02269-9101.

NFPA 704, *Standard System for the Identification of the Hazards of Materials for Emergency Response*, 1996 edition.

7-1.2 ANSI Publications. American National Standards Institute, Inc., 11 West 42nd Street, 13th floor, New York, NY 10036.

ANSI A117.1, *Specifications for Making Buildings and Facilities Accessible to and Usable by Physically Handicapped People*, 1992.

ANSI Z535.1, *Safety Color Code*, 1991.

Appendix A Explanatory Material

Appendix A is not a part of the requirements of this NFPA document but is included for informational purposes only. This appendix contains explanatory material, numbered to correspond with the applicable text paragraphs.

A-2-1 Approved. The National Fire Protection Association does not approve, inspect, or certify any installations, procedures, equipment, or materials; nor does it approve or evaluate testing laboratories. In determining the acceptability of installations, procedures, equipment, or materials, the authority having jurisdiction may base acceptance on compliance with NFPA or other appropriate standards. In the absence of such standards, said authority may require evidence of proper installation, procedure, or use. The authority having jurisdiction may also refer to the listings or labeling practices of an organization that is concerned with product evaluations and is thus in a position to determine compliance with appropriate standards for the current production of listed items.

A-2-1 Authority Having Jurisdiction. The phrase “authority having jurisdiction” is used in NFPA documents in a broad manner, since jurisdictions and approval agencies vary, as do their responsibilities. Where public safety is primary, the authority having jurisdiction may be a federal, state, local, or other regional department or individual such as a fire chief; fire marshal; chief of a fire prevention bureau, labor department, or health department; building official; electrical inspector; or others having statutory authority. For insurance purposes, an insurance inspection department, rating bureau, or other insurance company representative may be the authority having jurisdiction. In many circumstances, the property owner or his or her designated agent assumes the role of the authority having jurisdiction; at government installations, the commanding officer or departmental official may be the authority having jurisdiction.

A-2-1 Listed. The means for identifying listed equipment may vary for each organization concerned with product evaluation; some organizations do not recognize equipment as listed unless it is also labeled. The authority having jurisdiction should utilize the system employed by the listing organization to identify a listed product.

A-2-2 Referent. A referent may be abstract such as a condition concept, function, relationship, fact, or action.

A-2-2 Supplementary Indicators. Effectiveness of symbols can be supplemented by figures, numbers, subscripts, or letter abbreviations. These supplementary indicators may be placed inside of or adjacent to the symbol as seen fit. A legend of these indicators, with their meaning, should accompany each set of documents on which they are used.

A-2-2 Symbol. Ideally, a symbol should be graphically simple, should be readily understood, should have a strong impact, and should be easily remembered.

A-3-1.2.3 Changes in line thickness, scale, or details are not recommended. In practice, symbols may be combined with other symbols or devices such as words and lighted panels to provide optimal visual alerting.

A-3-1.2.4 The user is referred to other standards, such as those prepared by the NFPA Committee on Safety to Life and the ANSI Z535 Committee on Safety Signs and Colors, for such information.

A-3-1.3 Reflective material or self-luminous materials can be used. Consideration needs to be given to the proper mounting of self-luminous symbols in well-lighted locations to ensure charging by exposure to ambient light.

A-3-1.3.2 Exception Example of a prohibition symbol.

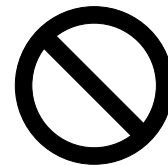

A-3-2 Use of the symbols is not restricted to the examples cited.

A-4-1.2.3 In practice, symbols can be combined with other devices, such as words and lighted panels, to provide optimal visual alerting. This chapter does not specify viewing distance, size, or optimal combinations of symbols, words, and other presentations.

A-4-1.3 Reflective material or self-luminous materials can be used. Consideration needs to be given to the proper mounting of self-luminous symbols in well-lighted locations to ensure charging by exposure to ambient light.

A-4-1.3.1 Drawing scale, line thickness, and so forth are the subject of standards on drawing practice.

A-4-2 Use of the symbols is not restricted to the examples cited.

A-4-2.5 The symbol can be of particular use where vehicles or snowfall frequently obscures hydrant locations.

A-5-1 This chapter on architectural and engineering symbols draws heavily on the symbols already developed by various societies, agencies, and industry.

A-5-1.2 The symbols in this chapter are intended to be simple, transferable by use of templates, and limited to those referents that are used repetitively in a set of drawings.

A-5-1.3 The effectiveness of the symbols in this chapter can be enhanced by the use of supplementary figures, subscripts, numbers, or letter abbreviations.

Devices infrequently used in a given set of drawings and diagrams are not standardized by this document. They usually are accompanied by narrative description, either on the drawing or in specifications.

A-5-1.4 *Diagram Preparation and Contents.* Where appropriate, diagrams include, but are not limited to, the following. (See Figure A-5-1.4.)

- (1) Title block indicating
 - a. Name of company or organization
 - b. Person making drawing and date of drawing
 - c. Name and location of facility involved
- (2) "North" direction arrow properly oriented to the position of buildings shown
- (3) Scale of diagram, if used, or "not to scale." Scale may be given with a bar measurement if reduction copies are to be made.

Figure A-5-1.4 Diagram to exemplify the use of symbols for risk analysis drawing.

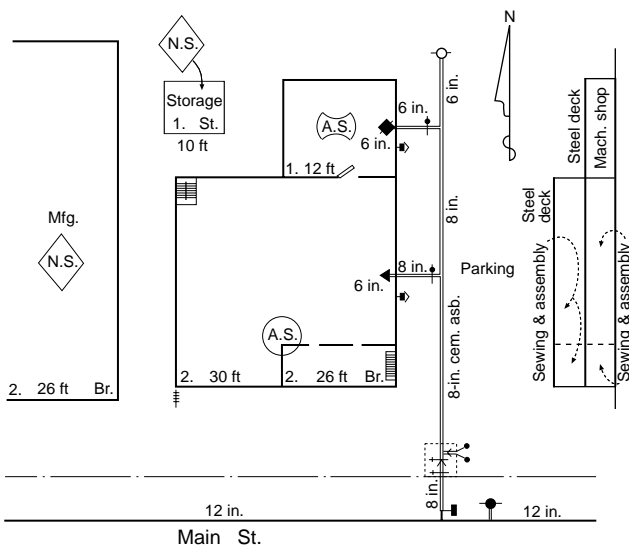

For SI units: 1 in. = 25 mm; 1 ft = 0.305 m

A-5-1.4.1 Drawing scale, line thickness, and so forth are the subject of standards on drawing practice.

A-5-1.4.4 The following are examples of symbol orientation.

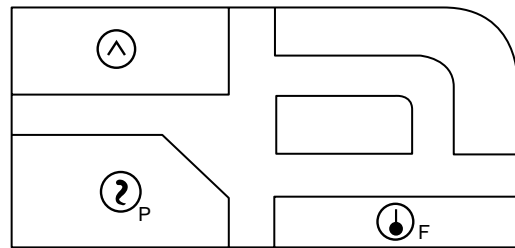
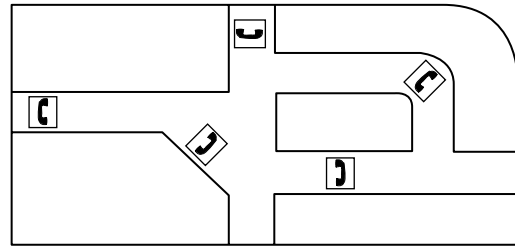

A-5-2.1.2 The following are examples of open-walled structures.

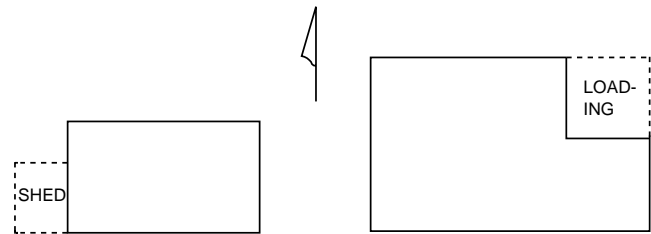

A-5-2.3 The following is an example of a street.



A-5-2.4 The following are examples of bodies of water.



A-5-2.5.2 The following is an example of a fence with a gate.



A-5-3.1 The following is an example of building construction identification. (See NFPA 220, *Standard on Types of Building Construction*.)

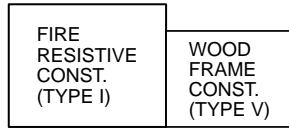

A-5-3.2 See Figure A-5-3.2 for an example of height symbols used for a building.

A-5-3.3.1 See Figures A-5-3.3.1 (a) and (b) for examples of wall symbols.

A-5-3.3.2 See Figure A-5-3.3.1 (a) for examples of parapet symbols used for a building.

A-5-3.5 See Figure A-5-3.5 for an example of cross-section symbols used for a building.

A-5-4.4 For 5-4.4.1 through 5-4.4.5, symbol elements can be utilized in any combination to fit the type of hydrant.

A-5-7.1.1 Electrical or mechanical actuation can be shown.

A-5-7.1.1(7) See NFPA 2001, *Standard on Clean Agent Fire Extinguishing Systems*, for generic list of clean agents.

A-5-7.1.1.1 The telephones referred to in 5-7.1.1.1 are those for a dedicated system for fire and related emergencies.

A-5-7.1.2.1 Temperature rating of heat detectors can be shown.

A-5-7.1.2.3 Velocity can be shown.

A-5-7.1.2.4 Drawing should show the type of gas or gases being monitored. Drawing should indicate the lower explosive limit (LEL) and/or the upper explosive limit (UEL) of gas or gases.

A-5-8 These symbols are intended for use in identifying the type of system installed to protect an area within a building.

A-5-8.2 For 5-8.2.1 through 5-8.2.7, temperature rating of sprinkler and other characteristics can be shown via legends where a limited number of an individual type of sprinkler is called for by the design.

A-5-8.3 See also Section 5-4 for related symbols.

A-5-12.3.1 The electrothermal link (ETL) is a multipurpose dual-response fusible link/release device. These devices are used in various applications, such as smoke/damper control and door closures. The symbol should be shown with its rated thermal point.

A-6-1.4 Triangle symbols are used for access features, assessment features, ventilation features, and utility shutoffs and can point at a specific location or direction. Diamond symbols identify a specific location by touching a wall. Circle symbols are used for all piping system appendatures, such as valves, since most pipes are round.

Square symbols are used for room designations, as they represent most rooms having four sides.

Figure A-5-3.2 Examples of building height symbols. (Figure includes copyrighted material of Insurance Services Office with its permission. Copyright, Insurance Services Office, 1975.)

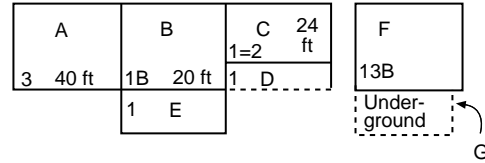

- A Three stories, no basement, 40 ft to eaves.
- B One story with basement, 20 ft to eaves.
- C One-equals-two stories, no basement, 24 ft to eaves.
- D One-story open porch or shed.
- E One-story addition.
- F Thirteen stories with basement.
- G Underground structure.

Figure A-5-3.1 (a) Symbols used to note wall ratings and parapets on life safety plans and risk analysis plans/cross sections.

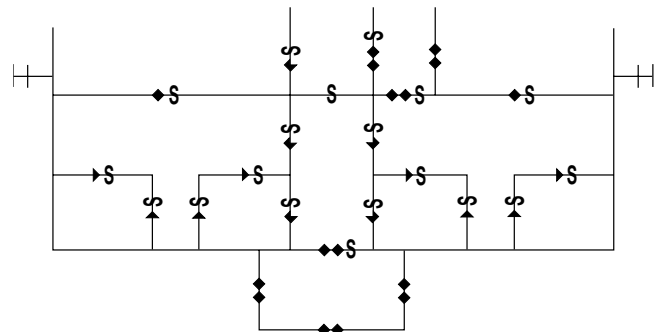

Figure A-5-3.1 (b) Symbol used to note wall ratings on design and construction documents.

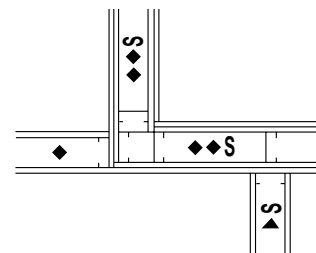
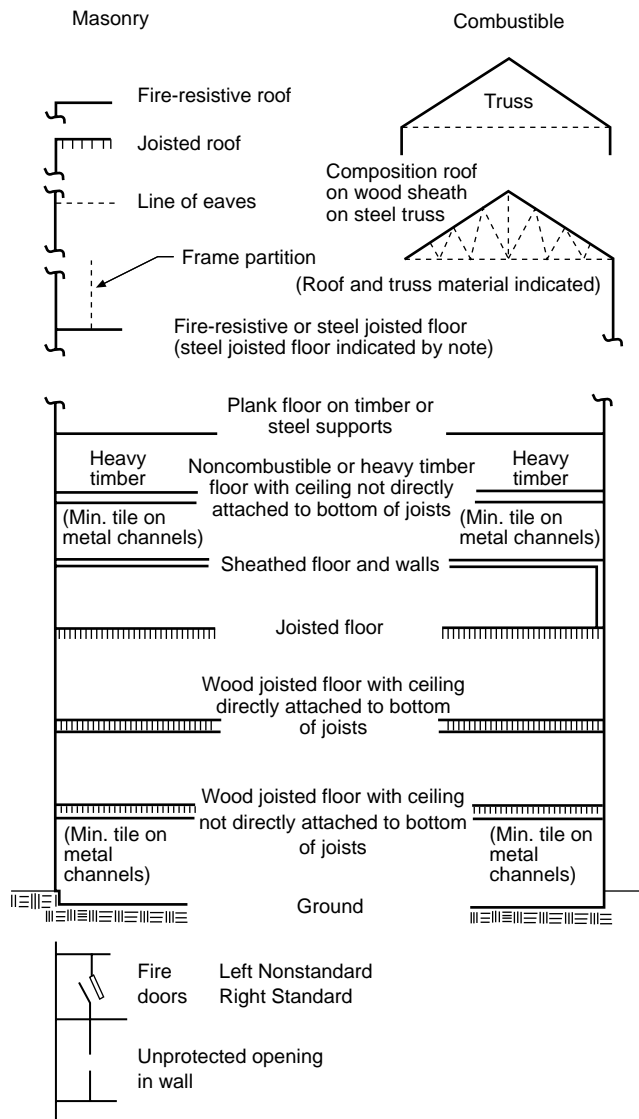

Figure A-5-3.5 Examples of symbols and notations used for fire risk analysis cross section. (Figure includes copyrighted material of Insurance Services Office with its permission. Copyright, Insurance Services Office, 1975.)



A-6-2 For Sections 6-2 through 6-5, other features to complete the pre-incident planning sketch can be used as appropriate.

A-6-6 The following is an example of hazardous identification.



Appendix B Additional Explanatory Information on Chapters 1 through 5

This appendix is not a part of the requirements of this NFPA document but is included for informational purposes only.

B-1 (Reserved.)

B-2 (Reserved.)

B-3 Additional Explanatory Information on Chapter 3.

B-3.1 Symbol Testing. Two or more versions of a symbol were developed for the referents listed in Chapter 3. The effectiveness of each of these symbols was evaluated by testing its meaningfulness (i.e., understandability) with groups of different participants. On the basis of these results, a symbol was selected for each referent. In some cases, the symbols were refined graphically to incorporate modifications suggested by the test results. Symbol development and refinement included the efforts of research psychologists, graphic designers, safety engineers, and fire professionals.

The life safety symbols were tested in the course of several different research projects during a 7-year period. These results are referenced in a series of publications by the National Bureau of Standards.

Although a variety of testing procedures were used to assess understandability, the basic method consisted of asking people either to write down short definitions or to pick the correct definition from a set of carefully selected choices. In several studies, data on symbol preference and rated effectiveness also were obtained.

For these testing efforts, one set of participants consisted of 222 industrial personnel and 78 students; another set consisted of 271 miners and mine personnel; and another set consisted of 94 paid volunteers. No major differences between participant groups were observed for the symbols selected for Chapter 3.

In addition to the studies of understandability, a detailed assessment was made of exit symbol visibility. This study used a laboratory optical viewing system to present a set of exit symbols included in a much larger set (108) of safety and information symbols. Three viewing conditions that simulated smoke were used (luminance of 0.085, 0.060, and 0.032 candela/m²). Forty-two participants were familiarized with a randomly selected set of exit symbols to identify the separate effects of understandability and visibility. The symbol given in Chapter 3 was the symbol that was most frequently identified correctly under all three viewing conditions. In addition, the identification data were virtually the same whether participants had been familiarized with the symbol or not — suggesting that the symbol has high initial understandability. (This suggestion is reinforced by the high percentages of correct identification found in those studies that evaluated understandability.)

The results of the visibility testing program are important because an exit symbol must be both well understood and visible when under degraded viewing conditions such as smoke.

The goal of the overall testing program was to identify versions or elements of symbols for the selected referents that appeared to be most effective in communicating the intended message. It is recognized that further education and/or supplemental word messages may be useful in optimizing the effectiveness of these symbols with the general public. Nevertheless, the symbols selected have demonstrated good initial understandability. Symbols for the referents generally showed good understandability (better than 85 percent correct identi-

fication). Symbols that presented some understandability problems included “No Exit” and “Fire Alarm Call Point.” The examples shown herein, however, represent the imagery that was best understood. It is hoped that use of these images will strengthen public recognition.

It also should be noted that the symbol for handicapped accessibility was not tested in this program. It is, however, in an existing ANSI standard, A117.1, *Specifications for Making Buildings and Facilities Accessible to and Usable by Physically Handicapped People*, and has achieved wide use and good recognition.

B-4 Additional Explanatory Information on Chapter 4.

B-4.1 Symbol Testing. At least two versions of a symbol were developed for each of the referents in 4-2.1 and 4-2.3 through 4-2.7. Referents 4-2.8 through 4-2.12 are discussed below. Subsequently, the effectiveness of the symbols was evaluated by testing their meaningfulness to groups of fire professionals; the procedures are outlined below. On the basis of the test results, a symbol was selected for each referent. This set of symbols was further refined graphically, incorporating modifications suggested by the test results. Symbol development and refinement through a Subcommittee on Visual Alerting Symbols included the efforts of fire professionals, graphic artists and designers, research psychologists, and safety engineers.

Symbols for referents 4-2.8 through 4-2.12 were adapted from International Organization for Standardization (ISO) publications. The fire extinguisher symbol (4-2.10) was included in the test procedure. Although the standpipe outlet symbol (4-2.9) was not tested in isolation, it was incorporated as an element in two of the tested symbols (4-2.3 and 4-2.4).

Participants in the test program included fire professionals attending a national convention or local (Maryland) training classes and totaled of 86 participants. The test procedure involved two phases. In the first phase, the participants were shown one symbol at a time, in slide form, and were asked to write down a short definition of what they thought each symbol meant. In the second phase, two symbolic versions of each referent were shown together, and their intended meaning was provided; the participants indicated which version (if either) of each pair they felt better conveyed the meaning. They also were asked to give the reason for their preference and were free to offer any suggestions for improvement.

The goal of the testing program was to identify versions or elements of symbols for the selected referents that were most effective in visually alerting fire fighters. It is recognized that education might be required to optimize the effectiveness of the symbols for fire fighters. Nevertheless, it is important to select symbols that initially are meaningful. Symbols for seven of the nine referents tested showed good recognizability (85–100%) and no serious confusion with other possible meanings. However, for two referents—wall hydrant and gas control valve—recognition was poor, and confusion was common for both symbolic versions of each message. Therefore, no symbol for these two referents is presented in this standard. Graphic improvements and alternative conceptions are being sought. (A symbol for a gas shutoff valve was accepted for the 1991 edition of NFPA 170, now 4-2.8 in this document.)

B-4.2 The NFPA Committee on Fire Safety Symbols was able to identify a set of shapes for symbols to be used to direct responding fire fighters.

B-5 Additional Explanatory Information on Chapter 5.

B-5.1 Symbol Selection Procedure. See Figure B-5.1 for an example of the procedures involved in selecting fire safety symbols.

B-5.2 Discussion of Basic Symbols.

B-5.2.1 Symbol Testing. Inevitably, when a new standard is introduced to a field in which standardized symbols are not established and everyone is acting independently, controversy looms over the effort as to which (whose) alleged “standard” should be used. Such controversy can only be met with a national logic for meeting the standardization task. Such logic was used in developing former NFPA 172, now incorporated into Chapter 5.

B-5.2.2 This symbology effort ultimately employed the following steps:

- (1) Identify problem. Is a standard for fire protection symbols needed?
- (2) Identify referents. What devices should be symbolized? Consider applicability to fire protection and frequency of use.
- (3) Identify symbols’ availability. What symbols exist, and how widely are they used for fire protection and other disciplines?
- (4) Develop a system of symbol selection. Can a system be identified so that referents and symbols can be rationally selected or developed? (*See B-5.1.*)
- (5) Can a scheme of basic shapes be utilized in developing symbol sets for categories of referents?
- (6) Adhere to the scheme. Make exceptions only where an overwhelming level of usage makes changes unreasonable.
- (7) Avoid conflicts. Are there other practices and/or standards with which the proposed standard might be in conflict?

B-5.2.3 To accomplish step B-5.2.2(5), two factors had to be considered. First, there is very little agreement on symbols throughout North America. For the most part, various industry segments disagree on symbols and even on basic shapes. Second, the ISO Committee on Fire Protection Symbols for Use on Drawings completed most of its work on this subject before 1980 and proposed a set of basic symbol shapes.

B-5.2.4 With the two foregoing considerations, the NFPA Committee on Fire Safety Symbols was able to develop a set of basic shapes for symbols to be used on fire protection drawings. The following basic shapes were selected by uniting the ISO proposed basic shapes and, where existent, the North American common practice. Thus, the collection of shapes (menu) represents a compromise with the sole major objective of developing a symbols standard aimed at a common language to improve future communication among users of fire protection drawings worldwide.

B-5.2.5 The collection of basic shapes in Table B-5.2.5 is broken down into a major classification of symbol elements and a supplementary set of symbol elements that can be used singly or in combination with other symbol elements. These basic symbol shapes and relative sizes are not exclusive of all the shapes and sizes that were used in developing former NFPA 172 (now incorporated into Chapter 5). They are a guide that was used in developing the family scheme.

It is recognized that former NFPA 172 did not include all the fire safety symbols that can be required on architectural and engineering drawings. Table B-5.2.5 can therefore be used as a basis for future development of Chapter 5 or for the design of specialized symbols by the draftsman.

Symbol elements have definite meanings and therefore should always be represented at the same relative size when used in different symbols.

Figure B-5.1 Symbol selection procedure.

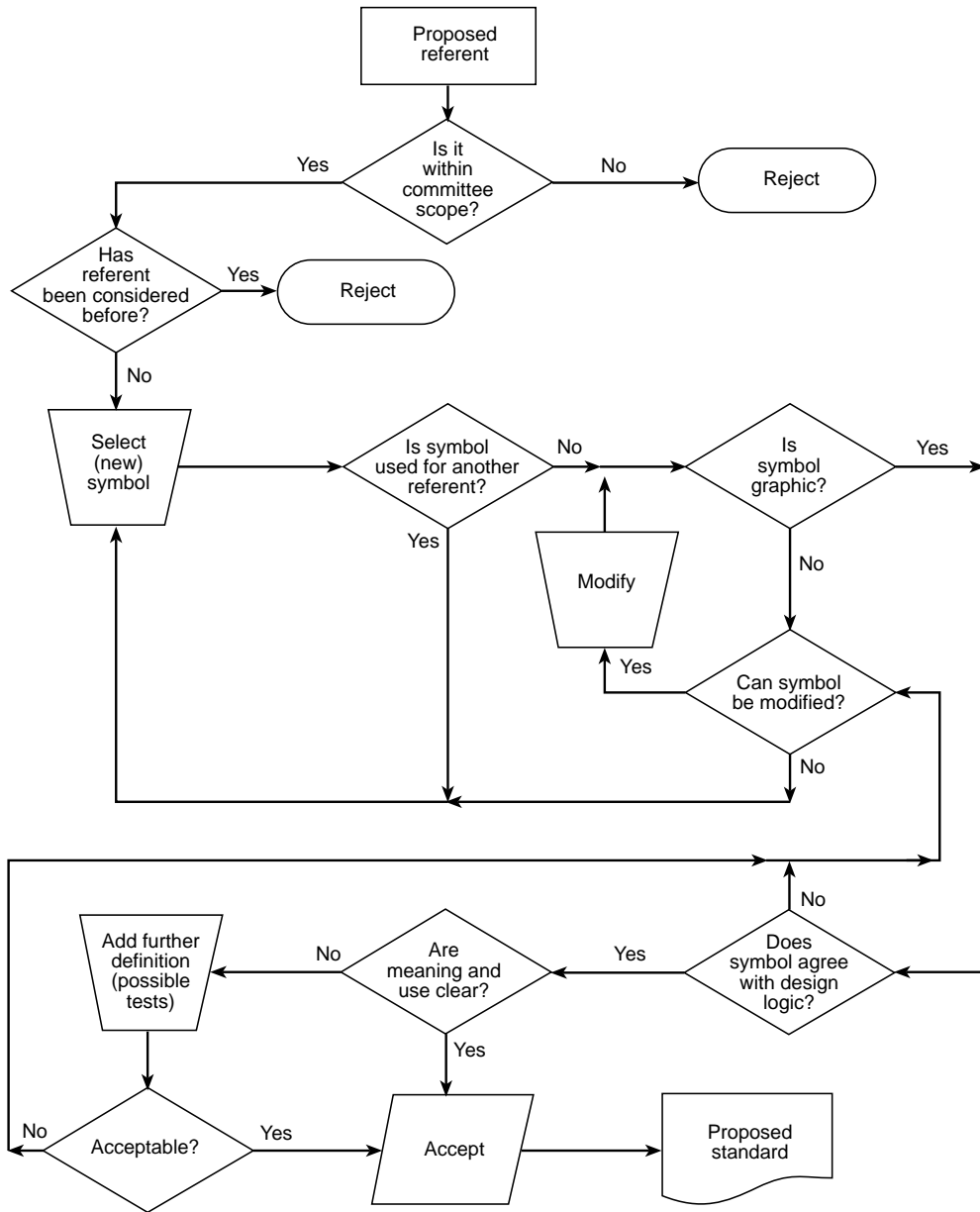

Table B-5.2.5 Basic Symbol Shapes and Relative Sizes

















General Referent	Shape	Relative Size [†]	Comments
MAJOR ELEMENTS			
Automatically actuating systems		$5/32$ in. dia.	Detection, extinguishment.
Manually actuating systems		$5/32$ in. square	Manual alarm system.
Control panel		$5/32$ in. \times $5/16$ in.	Supplementary element is used to describe the panel.
Portable fire extinguisher		$3/15$ in. sides	Supplementary element is used to further describe the extinguisher.
Fire-fighting equipment		$1/4$ in. sides	Supplementary element is used to describe a specific device.
SUPPLEMENTARY ELEMENTS			
Water system components		$3/32$ in. dia.	General shape, a circle. Shading of this element indicates a wet device.
Foam agent		$3/16$ in. dia.	
Dry chemical agent		$3/32$ in. square	
Gaseous agent		$1/8$ in. sides	
Nozzle			Used on pipe or other symbol.
Pressure notation			Used with another symbol shape, such as a detector or a tank.
Switch (electrical) or contact		0.075 in. dia.	

Table B-5.2.5 Basic Symbol Shapes and Relative Sizes (Continued)

General Referent	Shape	Relative Size [†]	Comments
Valve		5/32 in. high	
Check valve		1/4 in. high (with arrow)	
Tamper detector		5/32 in. dia.	
Heat detector		0.05 in. dia.	
Flow detector		5/32 in. square	

[†]Relative is emphasized since it is not the intent here to specify actual dimensions. For comparisons, this column lists the sizes of the symbols presented here.

B-5.2.6 The NFPA Committee on Fire Safety Symbols was able to identify a set of shapes for symbols to be used on fire protection drawings and diagrams (see Table B-5.2.5). The shapes were selected through a reconciliation of the symbols presented in former NFPA 172 (now incorporated into Chapter 5), the general shapes being drafted by ISO and, where existent, the common practice in North America. Thus, the family of shapes represents a compromise, with the major objective of developing a common language to improve future communication among users of fire protection diagrams worldwide.

B-5.3 Use of Color Coding.

B-5.3.1 General. The use of color coding to indicate various types of building construction is recommended and can be justified. Where used, color coding should be in conformity with this appendix to maximize communication. Where color coding is not used, it is necessary to rely on printed detail.

B-5.3.2 Table B-5.3.2 presents a recommended system for color coding.

Table B-5.3.2 Color Coding of Construction Types

Construction Type [†]	Color
Fire resistive (Type I)	Light brown
Noncombustible/limited combustible (Type II)	Gray (brown border if masonry walls)
Heavy timber and ordinary (Type III and IV)	Pink
Wood frame (Type V)	Yellow

[†]See NFPA 220, *Standard on Types of Building Construction*.

Appendix C Symbols for Life Safety Planning

This appendix is not a part of the requirements of this NFPA document but is included for informational purposes only.

C-1 The following symbols are presented for use in developing plans showing life safety related components. Other features that can be indicated include wall rating (see 5-3.3.1), emergency lighting (see 5-6.1), and so forth.

C-1.1 Egress Component Identifier.

E: __

Comments: Specify egress component.

EX# = Exit number

HE = Horizontal exit

EP = Exit passageway

CP = Common path of travel

PD = Public discharge

RD = Room number

ES = Escape

C-1.2 Egress Component Capacity.

< __ >

Comments: Specify allowable number of persons through egress component (e.g., < 25 >).

C-1.3 Governing Component Capacity.



Comments: Specify maximum capacity of the egress path.

C-1.4 Travel Distance.



Comments: Left side: Distance to egress component.
Right side: Egress component identifier.

C-1.5 Occupancy Capacity.

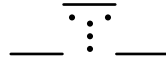

Comments: Top: Specify capacity.
Bottom left: Specify occupant load factor.
Bottom right: Specify area ft² (m²).

C-1.6 Fire Door.

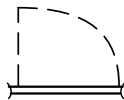

(1) Non-rated

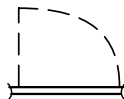

(2) Non-rated smoke-resistant

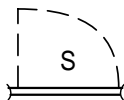

(3) 20-minute fire-rated

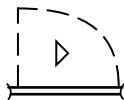

(4) 20-minute fire-rated, smoke-resistant

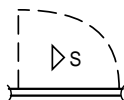

(5) 1/2-hour fire-rated

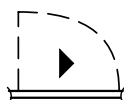

(6) 1/2-hour fire-rated, smoke-resistant

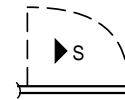

(7) 3/4-hour fire-rated

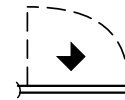

(8) 3/4-hour fire-rated, smoke-resistant

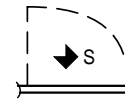

(9) 1-hour fire-rated, smoke-resistant



(10) 1-hour fire-rated, smoke-resistant

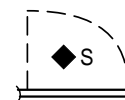

(11) 1 1/2-hour fire-rated



(12) 1 1/2-hour fire-rated, smoke-resistant



(13) 2-hour fire-rated



(14) 2-hour fire-rated, smoke-resistant

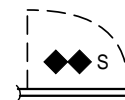

(15) 3-hour fire-rated



(16) 3-hour fire-rated, smoke-resistant

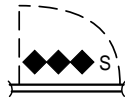

C-1.7 Exit.



Comments: Wide, black, solid line.

C-1.8 Exit Access.



Comments: Wide, black, dashed line.

C-1.9 Exit Discharge.



Comments: Wide, black, short, dashed line.

Appendix D Referenced Publications

D-1 The following documents or portions thereof are referenced within this standard for informational purposes only and are thus not considered part of the requirements of this standard unless also listed in Chapter 7. The edition indicated here for each reference is the current edition as of the date of the NFPA issuance of this standard.

D-1.1 NFPA Publications. National Fire Protection Association, 1 Batterymarch Park, P.O. Box 9101, Quincy, MA 02269-9101.

NFPA 220, *Standard on Types of Building Construction*, 1999 edition.

NFPA 2001, *Standard on Clean Agent Fire Extinguishing Systems*, 1996 edition.

D-1.2 ANSI Publication. American National Standards Institute, Inc., 11 West 42nd Street, 13th floor, New York, NY 10036.

ANSI A117.1, *Specifications for Making Buildings and Facilities Accessible to and Usable by Physically Handicapped People*.

Appendix E Informatory Publications

E-1 This appendix lists publications that are for informational purposes only.

E-1.1 NFPA Publications. National Fire Protection Association, 1 Batterymarch Park, P.O. Box 9101, Quincy, MA 02269-9101.

Fire Protection Handbook, 18th edition, 1997.

Inspection Manual, 7th edition, 1997.

National Fire Codes[®], 1999.

E-1.2 ANSI Publications. American National Standards Institute, Inc., 11 West 42nd Street, 13th floor, New York, NY 10036.

ANSI Z535.1, *Safety Color Code*, 1998.

ANSI Z535.4, *Production Safety Signs and Labels*, 1998.

E-1.3 FMRC Publications. Factory Mutual Research Corporation, 1151 Boston-Providence Turnpike, Norwood, MA 02061.

Factory Mutual Engineering Association, "Insurance Plan Manual," 1978.

Factory Mutual Insurance Co., "Graphic Symbols."

E-1.4 IEC Publication. International Electrotechnical Commission, 3 rue de Varembé, CH-1211 Geneva 20, Switzerland.

IEC, Pub. 117-3, *Graphical Symbols*, 1977.

E-1.5 IRI Information Publication. Industrial Risk Insurers, 85 Woodland Street, Hartford, CT 06102.

"The Insurance Plan," 1968.

E-1.6 ISO Publications. International Organization for Standardization, 1 rue de Varembé, Case Postale 56, CH-1211 Geneva 20, Switzerland.

ISO 3461-1976(E), *General Principles for the Creation of Graphical Symbols*, 1998.

ISO/TC21/SC1/N18, *Working Draft — Graphical Symbols for Fire Protection Plans*.

ISO/TC21/SC1 30E, *Proposal for Graphic Symbols*.

ISO/TC21/SC1/WG1-N27, *Graphical Symbols for Components of Automatic Fire Detection Systems*.

E-1.7 NEMA Publication. National Electrical Manufacturers Association, 1300 N. 17th Street, Suite 1847, Rosslyn, VA 22209.

NEMA Standard Pub. No. SB 1.1, *Symbols for Signaling, Protection and Communications Equipment*, 1969.

E-1.8 Additional Publications.

Aetna Casualty and Life Company, *Plan Symbols*, Hartford, CT, 1969.

American Institute of Architects, "A J Working Drawings Handbook — Technical Study 9," *The Architects' Journal*, May, 1977.

American National Standards Institute (ANSI Y32.2-1975), Canadian Standards Association (CSA Z99-1975), Institute of Electrical and Electronic Engineers (IEEE 315-1975), *Graphic Symbols for Electrical and Electronics Diagrams* (adopted for mandatory use October 31, 1975 by Department of Defense, United States of America).

American Telephone and Telegraph Company, "Firesafety Symbols," Basking Ridge, NJ.

American Telephone and Telegraph Company, Proposed Bell System Practice 760-220-152, "Building Planning," Basking Ridge, NJ, 1977.

Atwell, Vogel & Sterling, Inc., "NFPA Diagram Symbols" (Template), 1976.

Baltimore Fire Department Manual of Procedure, "Prefire Planning Sketches," Baltimore, MD, 1974.

Brand-Verhütungs-Dienst, "Symbols for Fire Protection Plans," Zurich, Switzerland, 1976.

British Standards Institute, "Graphic Symbols and Abbreviations for Fire Protection Drawings," B. S. 1635, London, England, 1970.

Brown & Root, Inc., "Firesafety Symbols," Houston, TX, 1978.

Canadian Standards Association, *Building Drawings*, First Draft C.S.A. B78.3-M, Rexdale, Ontario, Canada, 1977.

Collins, B. L., *The Development and Evaluation of Effective Symbol Signs*, National Bureau of Standards, Building Science Series, BSS 141, May 1982.

- Collins, B. L., *Use of Hazard Pictorials/Symbols in the Minerals Industry*, National Bureau of Standards, NBSIR 83-2732, March 1983.
- Collins, B. L. and Lerner, N. D., *An Evaluation of Exit Symbol Visibility*, National Bureau of Standards, NBSIR 83-2675, March 1983.
- Collins, B. L. and Lerner, N. D., "Assessment of Fire Safety Symbols," *Human Factors*, 1982, Vol. 24, pp. 75-84.
- Collins, B. L. and Pierman, P. C., *Evaluation of Safety Symbols*, NBSIR 79-1760, U.S. Department of Commerce, 1979.
- Collins, B. L., Lerner, N. D., and Pierman, B. C., *Symbols for Industrial Safety*, National Bureau of Standards, NBSIR 82-2485, April 1982.
- Construction Publishing Co., Inc., "Electrical Estimating Handbook," 1975.
- Dreyfuss, H., "Case Study: Symbols for Industrial Use" in G. Kepes (ed.) *Sign, Image and Symbol*, New York: George Braziller, 1966, pp. 126-133.
- Dreyfuss, H., *Symbol Sourcebook, An Authoritative Guide to International Graphic Symbols*, McGraw Hill, New York, 1972.
- Dutch Standard N.E.N. 1413, the Netherlands, "Symbols for Protection Against Fire on Building Drawings," Antwerp, Belgium, 1974.
- Easterby, R. S. and Swaga, H. I. G., *Evaluation of Public Information Symbols*, ISO Tests: 1975 Series, AP Report 60, March 1976.
- Fred S. James & Co., "Map Symbols," Chicago, IL.
- Freedman, M. and Berkowitz, M. S., *Preliminary Report on Laboratory and Pilot Field Testing: Testing Criteria and Techniques of Evaluation for Passenger/Pedestrian Oriented Symbols for Use in Transportation Related Facilities*, DOT-OS-60071, FIRL No. C4448, January 1977.
- Fremont, California Fire Department, "Fire Marshal's Office Standard Plan Symbols," Fremont, California.
- Grinnell Fire Protection Systems Company, Inc., "Graphical Standards."
- Illinois Bell Telephone, "Fire Safety Symbols," Chicago, IL.
- Improved Risk Mutuals, "Firemen's Manual," White Plains, NY.
- Improved Risk Mutuals, "Protection Symbols."
- Improved Risk Mutuals, "Standard Abbreviations, Symbols, and Colors for Use on Insurance Plans," White Plains, NY.
- Insurance Services Office, "Standard Plan Symbols," Chicago, IL, 1956.
- Insurers' Advisory Organization of Canada, "Standard Key of Signs," Toronto, Ontario, Canada, 1977.
- International Fire Service Training Association, "Fire Prevention and Inspection Practices," No. 110, 4th edition, Tulsa, OK.
- International Fire Service Training Association, "Fire Problems in High Rise Buildings," Tulsa, OK.
- Johnson Controls, Inc., "Abbreviations and Symbols," Milwaukee, WI.
- Kolers, P. A., "Some Formal Characteristics of Pictograms," *American Scientist*, Vol. 57, No. 3, 1969, pp. 348-363.
- Massachusetts Fire Alarms, "Fire Safety Symbols," Lowell, MA.
- Mead, M. and Modley, R., "Communication Among All People, Everywhere," *Natural History*, Vol. 77, No. 7, 1968, pp. 56-63.
- Metropolitan Government of Nashville and Davidson County, "Building Symbols," 1978.
- Modley, R., "Graphic Symbols for World-Wide Communication," in G. Kepes (ed.) *Sign, Image and Symbol*, New York: George Braziller, 1966, pp. 108-125.
- Modley, R. and Myers, W. R., *Handbook of Pictorial Symbols*, New York: Dover Publications, 1976.
- Nashville, Tennessee Metropolitan Fire Dept., "Building Symbols," Nashville, TN.
- National Automatic Sprinkler and Fire Control Association, Inc., "Symbol Standards."
- New Zealand Standard Association, "Building Drawing Practice—Engineering Services Maintenance and Fire Control Drawings" (proposed Part V of N.Z.S. 5902), Wellington, New Zealand.
- Oklahoma State University, "OSU Safety Department Fire Alarm Symbols," OK.
- Phenix Technology, Inc., "Fire Pre-Planning Symbols."
- Pyrotronics, Inc., "Fire Alarm Symbols," Cedar Knolls, NJ.
- Salem, Massachusetts Fire Department, "Fire Alarm Symbols," Salem, MA.
- Santa Clara County, Procedures Manual, "F.M.O. Standard Plan Symbols," Santa Clara County, CA, 1973.
- Signal Communications, Inc., "Fire Alarm Symbols."
- Swiss Standard, "Symbols for Fire Protection Plans," November, 1977.
- Taft Fire Control District, "Standard Prefire Plan Symbols," Taft, FL.
- Texas Eastman Company, "Symbols for Fire Protection Drawings," Longview, TX.
- University of Maryland, "Firemen's Training Course," Section II — Advanced, College Park, MD.

Index

©1999 National Fire Protection Association. All Rights Reserved.

The copyright in this index is separate and distinct from the copyright in the document that it indexes. The licensing provisions set forth for the document are not applicable to this index. This index may not be reproduced in whole or in part by any means without the express written permission of the National Fire Protection Association, Inc.

- A-**
- Aboveground tanks** 5-3.6.4
- Access, fire department**
 Drawing and diagram symbols 5-2.7
 Pre-incident planning sketch symbols 6-2.1
- Air-conditioning equipment rooms** 6-5.1
- Alarms, fire**
 Drawing and diagram symbols 5-7
 Manual *see* Manual alarms
 Pre-incident planning sketch symbols 6-2.2.1 to 6-2.2.3
- Approved (definition)** 2-1, A-2-1
- Architectural drawings, symbols for** *see* Drawings and diagrams, symbols for
- Arrows, directional** 4-2.11 to 4-2.12, A-5-1.4(2)
- Authority having jurisdiction (definition)** 2-1, A-2-1
- B-**
- Boiler rooms** 6-5.6
- Boilers** 5-3.6.1
- Building construction, symbols for** 5-3, A-5-3
- Buildings, symbols for** 5-2.1, A-5-2.1.2
- C-**
- Campfires prohibition** 3-2.10
- Child care center** 4-2.13
- Chimneys** 5-3.6.2
- Compressed natural gas shutoff** 6-2.4.3.1.3
- Connections, fire department** *see* Fire department connections
- Construction, building, symbols for** 5-3, A-5-3
- Control devices, sprinkler system** 5-8.3
- Control panels** 5-5, Table B-5.2.5
- Cooking prohibition** 3-2.12
- Cross-sections** 5-3.5, A-5-3.3.1 to A-5-3.5
- D-**
- Definitions** Chap. 2, A-2
- Detection equipment and systems**
 Drawing and diagram symbols 5-7, Table B-5.2.5
 Pre-incident planning sketch symbols 6-3
- Diagrams** *see also* Drawings and diagrams, symbols for
 Preparation and contents A-5-1.4
- Directional arrows** 4-2.11 to 4-2.12, A-5-1.4(2)
- Door holders** 5-7.3.1
- Doors, fire** 5-3.4.2 to 5-3.4.3, C-1.6
- Drawings and diagrams, symbols for** Chap. 5, A-5
 Alarms, fire 5-7
 Application 5-1.3, A-5-1.3
 Building construction 5-3, A-5-3
 Color coding, use of B-5.3
 Control panels 5-5
 Descriptions of symbols 5-2 to 5-12
 Detection equipment 5-7
 Development B-5.2
 Extinguishers, portable fire 5-9
 Extinguishing systems 5-8
 Fire-fighting equipment 5-10
 Means of egress 5-6
 Miscellaneous 5-12
 Orientation 5-1.4.4, A-5-1.4.4
 Presentation 5-1.4, A-5-1.4
- Scale 5-1.4.3, A-5-1.4(3)
- Screened lines 5-1.4.2
- Selection procedure B-5.1
- Shapes 5-1.4.1, A-5-1.4.1, B-5-2.4 to B-5.2.6
- Site features 5-2, A-5-2.1.2 to A-5-2.5.2
- Sizes, relative Table B-5.2.5
- Smoke/pressurization control 5-11
- Sprinkler 5-8.2
- Testing B-5.2.1
- Uniformity in use of 5-1.2, A-5-1.2
- Water supply and distribution 5-4
- Dry chemical extinguishing systems** 5-8.1.2, 6-3.8
- Dry chemical portable fire extinguishers** 5-9.4
- E-**
- Egress, means of** *see* Means of egress
- Electric panel or electric shutoff** 4-2.7, 6-2.4.1
- Electrical/transformer rooms** 6-5.7
- Elevators**
 Building construction symbols 5-3.4.4 to 5-3.4.5
 Equipment rooms 6-5.2
 Prohibition of use 3-2.8
- Engineering drawings, symbols for** *see* Drawings and diagrams, symbols for
- Equipment rooms** 6-5
- Escalators** 5-3.4.7
- Exits**
 Drawing and diagram symbols 5-3.6.3, 5-6
 General use symbols 3-2.1 to 3-2.8
 Symbols for C-1.7 to C-1.9
- Extinguishers, portable fire**
 Drawing and diagram symbols 5-9, Table B-5.2.5
 Fire service symbols 4-2.10
- Extinguishing agents** Table B-5.2.5
- Storage containers 5-12.1
- Extinguishing systems**
 Drawing and diagram symbols 5-8, A-5-8, Table B-5.2.5
 Pre-incident planning sketch symbols 6-3
- F-**
- Fences** 5-2.5, A-5-2.5.2
- Fire department access** *see* Access, fire department
- Fire department connections**
 Drawing diagram symbols 5-4.5
 Fire service use symbols 4-2.1 to 4-2.4
 Pre-incident planning sketch symbols 6-4.9
- Fire doors** 5-3.4.2 to 5-3.4.3, C-1.6
- Fire escapes** 5-3.6.3
- Fire-fighting equipment** 5-10, Table B-5.2.5
- Fire-fighting hoses** 4-2.9
- Fire hydrants** *see* Hydrants
- Fire pumps** 5-4.6, 6-4.6
- Fire risk diagrams** *see* Risk analysis drawings
- Fire service use, symbols for** Chap. 4, A-4
 Background 4-1.3.2
 Color 4-1.2.3, 4-1.3.2.2, 4-1.3.3
 Descriptions of symbols 4-2
 Fundamental imagery 4-1.2.3, A-4-1.2.3
 Orientation 4-1.3.4
 Presentation 4-1.3, A-4-1.3
 Shapes 4-1.2.3, 4-1.3.1, 4-1.3.2.1, A-4-1.3.1, B-4.2
 Testing B-4.1

- Uniformity in use of 4-1.2
Use of A-4.2
- Flame detectors** 5-7.1.2.5
- Floor assemblies** 5-3.5.1
- Floor openings** 5-3.4
- Fusible links** 5-12.3, A-5-12.3.1
- G-**
- Gas detectors** 5-7.1.2.4, A-5-7.1.2.4
- Gas shutoff** 6-2.4.3
- Gas shutoff valves** 4-2.8
- Gaseous mediums, systems utilizing** 5-8.1.3
- General use, symbols for** Chap. 3, A-3
Color 3-1.2.3, 3-1.3.3
Descriptions of symbols 3-2
Fundamental imagery 3-1.2.3, A-3-1.2.3
Presentation 3-1.3, A-3-1.3
Shape 3-1.2.3, 3-1.3.2
Testing B-3.1
Uniformity in use of 3-1.2
Use of A-3-2
- Generator rooms, emergency** 6-5.3
- H-**
- Hangers, sprinkler pipe** 5-8.3
- Hazardous materials, identification of** 6-6
- Heat detectors**
Drawings and diagrams, symbols for 5-7.1.2.1,
A-5-7.1.2.1, Table B-5.2.5
Pre-incident planning sketch symbols 6-3.2
- Height (building), symbols for** 5-3.2, A-5-3.2
- Hoistways, open** 5-3.4.6
- Hose cabinets or connections** 6-4.4
- Hoses, fire fighting** 4-2.9
- Hydrants**
Drawing and diagram symbols 5-4.4, A-5-4.4
Fire service use symbols 4-2.5, A-4-2.5
Pre-incident planning sketch symbols 6-4.5, 6-4.8
- I-**
- Indicating appliances** 5-7.2
- Informatory publications** App. E
- Insurance diagrams, symbols for** *see* Drawings and diagrams,
symbols for
- International System of Units (SI)** 1-3
- L-**
- Labeled (definition)** 2-1
- Life safety planning symbols** A-5-3.3.1 to A-5-3.3.2, App. C
- Lights**
Emergency 5-6
Indicating 5-7.2.4 to 5-7.2.5
- Listed (definition)** 2-1, A-2-1
- Loss analysis diagrams** *see* Drawings and diagrams, symbols for
- LP-Gas shutoff** 6-2.4.3.1.1
- M-**
- Mains, pipe** 5-4.1
- Manual alarms**
Drawing and diagram symbols 5-7.1.1, A-5-7.1.1, Table B-5.2.5
General use symbols 3-2.11
Pre-incident planning sketch symbols 6-3.5
- Means of egress** *see also* Exits
Drawing and diagram symbols 5-6
Life safety planning symbols C-1
- Measurement, units of** 1-3
- Meters** 5-4.3
- N-**
- Natural gas shutoff** 6-2.4.3.1.2
- O-**
- Openings (floor, wall, roof)** 5-3.4
- P-**
- Parapets** 5-3.3.2, A-5-3.3.2
- Piping, sprinkler system** 5-8.3
- Pre-incident planning (definition)** 2-2
- Pre-incident planning sketches, symbols for** Chap. 6, A-6
Access features 6-2.1
Application 6-1.3
Assessment features 6-2.2
Detection/extinguishing equipment 6-3
Equipment rooms 6-5
Hazardous materials, identification of 6-6
Shapes 6-1.4, A-6-1.4
Uniformity in use of 6-1.2
Utility shutoffs 6-2.4
Ventilation features 6-2.3
Water flow control valves and water sources 6-4
- Pressurization control** 5-11
- Pressurization panel** 6-2.2.4
- Prohibition symbols** 3-1.3.2, A-3-1.3.2
Orientation 3-1.3.1
Types 3-2.5, 3-2.8 to 3-2.10, 3-2.12
- Property lines** 5-2.6
- Pump rooms** 6-5.4
- Pumps, fire**
Drawing and diagram symbols 5-4.6
Pre-incident planning sketch symbols 6-4.6
- Purpose of standard** 1-2
- R-**
- Railroad tracks** 5-2.2
- Referenced publications** Chap. 7, App. D
- Referent (definition)** 2-2, A-2-2
- Refuge, area of** 3-2.13
- Risk analysis drawings** *see also* Drawings and diagrams,
symbols for
Symbols used for A-5-3.3.1 to A-5-3.5
- Roof assemblies** 5-3.5.1
- Roof openings** 5-3.4
- S-**
- Scope of standard** 1-1
- Screen/strainer** 5-4.7
- Self-luminous** A-3-1.3, A-4-1.3
Definition 2-2
- Shall (definition)** 2-1
- Should (definition)** 2-1
- Shutoff valves, gas** 4-2.8
- Shutoffs, utility** 4-2.7 to 4-2.8, 6-2.4
- Siamese fire department connections**
Drawing and diagram symbols 5-4.5.1 to 5-4.5.2
Fire service use symbols 4-2.1
- Skylights** 5-3.4.11, 6-2.3.1
- Smoke control**
Drawing and diagram symbols 5-11
Pre-incident planning sketch symbols 6-2.2.4

Smoke detectors
 Drawing and diagram symbols . . . 5-7.1.2.2 to 5-7.1.2.3, A-5-7.1.2.3
 Pre-incident planning sketch symbols 6-3.3, 6-3.13

Smoke vents 6-2.3.2

Smoking prohibition 3-2.9

Spray nozzles, special 5-12.2

Sprinkler systems
 Drawing and diagram symbols 5-8.1.4, 5-8.2 to 5-8.3
 Fire service use symbols 4-2.1 to 4-2.2, 4-2.4, 4-2.6
 Pre-incident planning sketch symbols 6-2.2.5, 6-4.1 to 6-4.3

Stairs
 Building construction symbols 5-3.4.8 to 5-3.4.10
 Use in case of fire, symbols for 3-2.6 to 3-2.7

Standpipes
 Fire department connections 4-2.3 to 4-2.4
 Outlets 4-2.9

Streets 5-2.3, A-5-2.3

Supplementary indicators (definition) 2-2, A-2-2

Symbols (definition) 2-2, A-2-2

-T-

Tanks
 Drawing and diagram symbols 5-3.6.4 to 5-3.6.5
 Pre-incident planning sketch symbols 6-4.11

Telephone equipment rooms 6-5.5

Testing
 Drawing and diagram symbols B-5.2.1
 Fire service use symbols B-4.1
 General use symbols B-3.1

Transformer rooms 6-5.7

-U-

Underground tanks 5-3.6.5

Utility shutoffs 4-2.7, 6-2.4

-V-

Valves Table B-5.2.5
 Drawing and diagram symbols 5-4.2
 Gas shutoff 4-2.8
 Solenoid 5-12.4
 Sprinkler control 4-2.6
 Sprinkler system 5-8.3
 Water flow control 6-4.1 to 6-4.3

Ventilation features 5-11.5, 6-2.3

Vents, smoke 6-2.3.2

-W-

Wall openings 5-3.4

Walls 5-3.3.1, A-5-3.3.1

Water, bodies of 5-2.4, A-5-2.4

Water flow control valves 6-4.1 to 6-4.3

Water flow detectors/alarms
 Drawing and diagram symbols 5-7.1.2.6, 5-7.2.3, Table B-5.2.5
 Pre-incident planning sketch symbols 6-2.2.5, 6-3.4

Water shutoff 6-2.4.2

Water supply and distribution 5-4, 6-4, Table B-5.2.5

Water tanks 6-4.11

Water-based extinguishing systems 5-8.1.1

Symbols for Chapter 3 of *NFPA 170*, 1999 Edition

(See reverse side for Chapter 4 symbols.)



*

Emergency Exit



*



Use Stairs
in Case of Fire



*

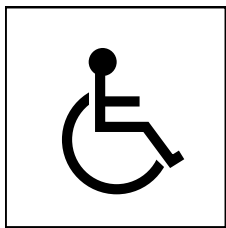

Use Stairs
in Case of Fire

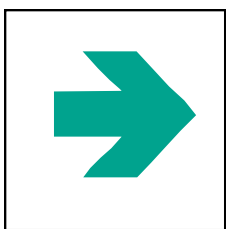

**

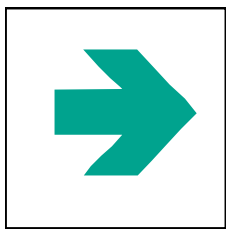

**

Accessible Emergency
Exit Route

Emergency Exit
Route



No Smoking



*



*

Not an Exit

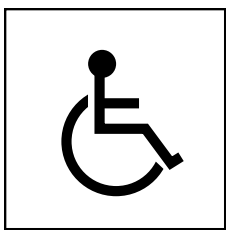

Accessible Emergency
Exit

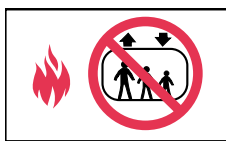

Do Not Use Elevator
in Case of Fire



No Campfires

* Image can be green or black
** Arrow can be green or black

Symbols for Chapter 4 of *NFPA 170*, 1999 Edition

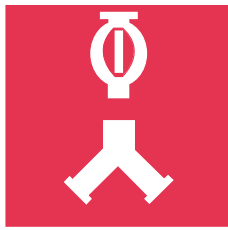

Fire Department Automatic Sprinkler Connection — Siamese

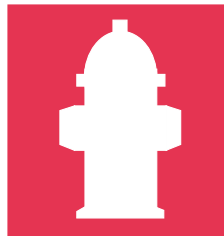

Fire Hydrant (All Types)

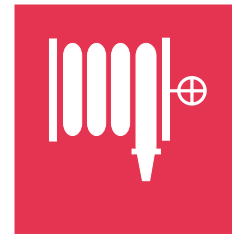

Fire-Fighting Hose or Standpipe Outlet



Fire Department Automatic Sprinkler Connection — Single

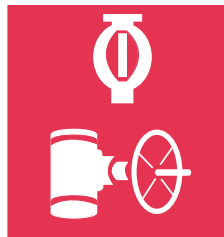

Automatic Sprinkler Control Valve



Fire Extinguisher



Fire Department Standpipe Connection

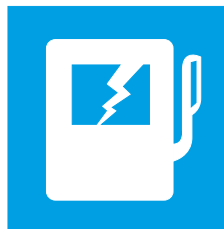

Electric Panel or Electric Shutoff

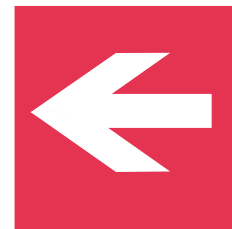

Directional Arrow *

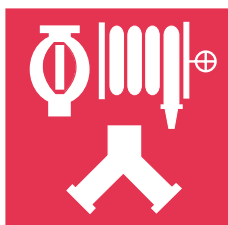

Fire Department Combined Automatic Sprinkler/Standpipe Connection

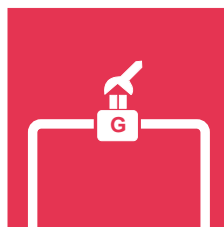

Gas Shutoff Valve

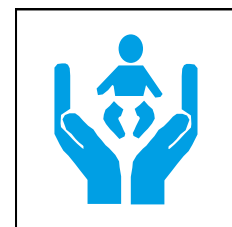

Child Care Center

* Background can be red or blue