



Touchscreen Comfort Control



Model TCONT624AS42DA User Guide and Installation Instructions

Nexia Home Intelligence
Customer Service:
(877) 288-7707

**For HVAC related
issues, contact your
servicing dealer**

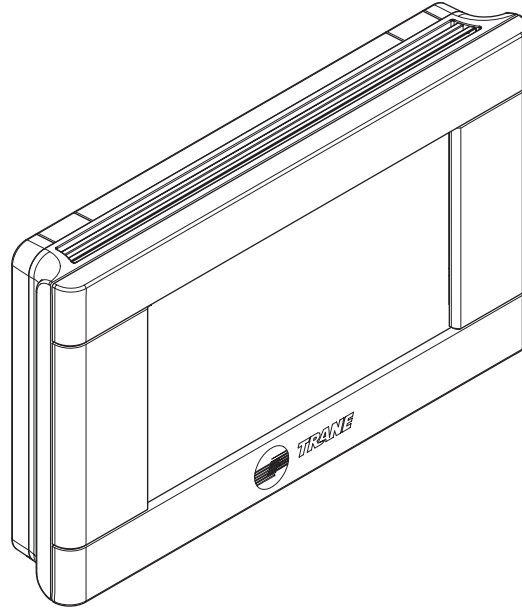

➔ **NOTE:** A 24 Volt common and hot wire **MUST** be connected to the TCONT624A for operation.

Contents

User Guide

Features	2
Operation	3
User Settings	4
Scheduling	5
Enrolling into “Z-Wave” Network (Nexia™ Home Intelligence).....	8
Firmware Upgrades	10
About	11
Clean Screen	11

Installer’s Guide

Product Specifications	12
Installation and Wiring	12
Physical Location	12
Field Wiring Diagrams	14
Optional Remote Temperature Sensors Installation	31
Installer’s Setup	32
Test Mode	35
Restore Defaults	35
Troubleshooting	36
Limited Warranty	38
FCC/IC Notice	40

Features

TCONT624AS42DA Features

- 24v, Z-Wave comfort control
- Remote access via smart phone, tablet, or P.C. (requires SK101 and a Nexia™ Home Intelligence account).
- Interactive 4.3" black & white touchscreen
- 7 Day programmable, 4 schedules/day
- Built in humidity sensor with RH display
- Filter, maintenance, humidifier service reminders
- Remote temperature sensing option (1 indoor/1 outdoor)
- Auxiliary & compressor heat lockouts
- Dehumidification (overcooling)
- Enhanced dehumidification (cooling)
- Adjustable variable speed fan settings (pwm)
- Energy Savings Mode (ESM)
- Screen lock and guest lock
- Upgradable firmware (requires a Nexia™ Home Intelligence account).
- Service test modes
- Humidifier control

User Guide

Operation

The model TCONT624AS42DAA Comfort Control provides typical operation of a forced air heating and cooling HVAC system. The TCONT624 comfort control also features a Z-Wave™ module for remote control.

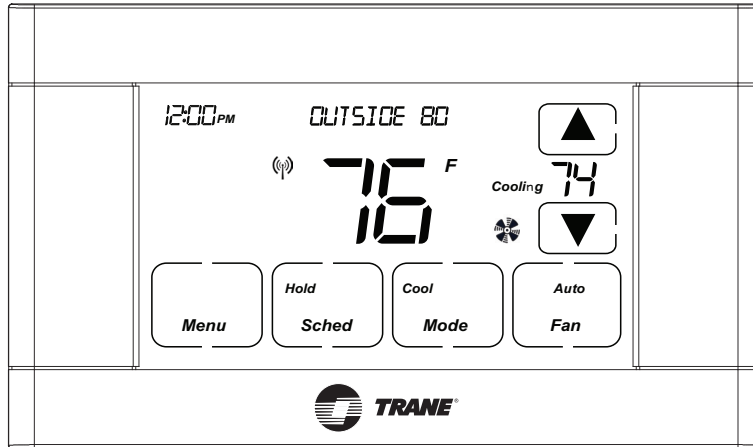

Normally, the Comfort Control displays the Home Screen as shown above.

Item	Description	Notes
Clock Display	The current time is displayed in the upper left corner of the main screen. The time will blink when the clock has not been set.	See TIME/DATE for more information. If the control is connected to Nexia Home Intelligence the clock will be updated by the Nexia portal.
Dynamic Labels and Function Control Buttons	The buttons are defined by the dynamic labels in each button. As you navigate through menus, the labels for the buttons will change.	
Setpoint Display and Setpoint Up/Down Buttons	The current heat or cool setpoint is displayed. These setpoints may be set using Nexia Home Intelligence, the Control's internal schedule, or by pressing the Setpoint Up/Down buttons. Pressing the setpoint button changes the setpoint screen. The current mode is displayed at the top of the screen. Adjust the setpoint by pressing the up or down arrows. To change setpoint mode press the MODE button.	The setpoints will push each other if they are adjusted to within the minimum heat/cool separation setting. This is normally 3 degrees.
Temperature Display	The Comfort Control displays the current temperature as sensed by the internal temperature sensor.	The internal temperature sensor can be adjusted as necessary.
Menu Button	Button used to access other Comfort Control menus	Other Comfort Control menus can be accessed by pressing the MENU button.
System Mode Button	Button used to change the system mode	Off: System off Heating: Heating only Cooling: Cooling only Auto: Heating/Cooling as necessary EM Heat: Indoor Heat only
Fan Mode Button	Button used to change the fan mode:	Auto: Fan on when cooling/heating is necessary On: Fan constantly on Circ: Fan on for a user-selected number of minutes per hour.
Schedule Mode Button	Button used to change the schedule mode:	Hold: System maintains the current temperature setpoints. Schedules are disregarded. Run: Run the system schedule Energy Saving Mode (ESM): Temperature setpoints in ESM Setpoints are maintained.

User Guide

User Settings

User Settings allow the user to customize various settings on the 624 control. To access User Settings simply press the Menu button once and “User Settings” will be displayed. To enter the User Settings menu, press the Select button, then use the Next button to navigate through the options below. The default setting will be shown in brackets. After each selection press the Done button to save changes.

Thermostat		
Setting	Range	Description
Temperature Scale	[Fahrenheit], Celsius	Select the temperature display scale
Cooling RH Setpoint	30% - 60% [50%]	Select the desired indoor relative humidity during cooling mode. Dehumidification must be enabled in the Installer Settings for this option to be available.
Heating RH Setpoint	10% - 45% [40%]	Select the desired indoor relative humidity during heating mode. Humidification must be enabled in the Installer Settings for this option to be available.
Smart Continuous Fan	Yes, [No]	If yes is selected, continuous fan mode is disabled when indoor humidity exceeds the Cooling RH Setpoint
Continuous Fan Airflow	35% - 100% [50%]	Select the desired fan speed when the Fan Mode selected is Continuous (variable speed blower required)
Fan Circulate On Time	1 - 59 minutes, [Off]	Select the desired amount of time the fan will cycle per hour when the Fan Mode selected is Circ
Local Schedule Enable	[Yes], No	Select whether scheduling will be enabled or disabled
Max Heat Setpoint	55 - [90] Degrees	Select the highest heating setpoint allowed
Min Cooling Setpoint	[60] - 99 Degrees	Select the lowest cooling setpoint allowed
H/C Delta	[3] - 15 Degrees	Select the minimum deadband between Heating and Cooling setpoints
Once all selections have been made, press the Done button to exit and return to Menu. Press Next to navigate to the next setting.		
Energy Savings Mode		
Setting	Range	Description
ESM Heat Setpoint	55 - 90 degrees [62]	Select the desired Heating Setpoint when ESM (Energy Savings Mode) is selected
ESM Cooling Setpoint	60 - 99 Degrees [85]	Select the desired Cooling Setpoint when ESM (Energy Savings Mode) is selected
Once all selections have been made, press the Done button to exit and return to Menu. Press Next to navigate to the next setting.		
Display		
Setting	Range	Description
Screen Timeout	[0] - 90 Seconds	Select how long after the last button press before the screen timeouts to a minimized screen
Backlight Timeout	0 - 90 Seconds [20]	Select how long after the last button press before the backlight dims
Backlight On Percent	0 - [100] Percent	Select the screen brightness when the backlight is lit
Backlight Off Percent	[0] - 100 Percent	Select the screen brightness when the backlight timeout expires
Buzzer Enable	[Yes], No	Select whether button presses are audible
Security	[Unlocked], Display Lock, Guest Access	Select security level <ul style="list-style-type: none"> • Unlocked - Enables selection of all menus and settings • Display Lock - Disables selection of all menus and settings • Guest Access - Disables selection of all menus and settings except the following: Raise or lower heating or cooling setpoint +/- 5 degrees and change system mode Note: When Display Lock or Guest Lock is selected a lock icon will appear next to the up arrow. Note: To disable Display Lock or Guest Access, press and hold the up and down arrows until the lock icon disappears.
Once all selections have been made, press the Done button to exit and return to Menu. Press Next to navigate to the next setting.		

User Guide

User Settings Continued

Time/Date		
Setting	Range	Description
Hour	1 - 12 am, 1 - 12 pm	Select the current hour of day
Minutes	0 - 59	Select current minute of day
Day of Week	Sun - Sat	Select current day of week
Year	2013 - 2113	Select current year
Month	Jan - Dec	Select current month of year
Date	1 - 31	Select current day of month
Once all selections have been made, press the Done button to exit and return to Menu. Press Next to navigate to the next setting.		
Reminders		
Setting	Range	Description
Filtration Enable	Yes, [No]	Selecting yes, enables the Filter Reminder feature
Filter Period	[Monthly], Quarterly, Semi-Annually, Annually	Select how often the reminder will be displayed
Filter Start Month	[Jan] - Dec	Select the Filter Reminder start month
System Maint Enable	Yes, [No]	Selecting yes, enables the System Maintenance Reminder feature
First Maint Month	Jan - Dec	Select the first System Maintenance month
Second Maint Month	Jan - Dec	Select the second System Maintenance month
Once all selections have been made, press the Done button to exit and return to Menu. Press Next to navigate to the next setting.		

Scheduling

Schedule Setup Procedure

The 624 comfort control is preset at the factory with a 7 Day energy savings schedule. Each day of the week is pre-programmed with the following schedule:

Scheduling			
Time	Schedule Name	Heat Temperature Setting	Cool Temperature Setting
6:00 AM	Wake	70 F	78 F
8:00 AM	Day	62 F	85 F
6:00 PM	Evening	70 F	78 F
10:00 PM	Night	62 F	78 F
The schedule may be changed locally at the control with the Edit Schedule menu. If the 624 comfort control is connected to Nexia Home Intelligence the schedule may be changed remotely from the Nexia website using the website's Edit Schedule menu.			

User Guide

Scheduling

Edit Schedule (Local)

Press the following button sequence to edit or create an entirely new daily schedule.

Edit Schedule		
Button Press	Menu Displayed	What Needs to Be Done?
Press Menu from Home screen	USER SETTINGS	
Press Next	SCHEDULE	
Press Select	EDIT SCHEDULE	
Press Select	SELECT DAY	Continue to press "Next" until the day of week to edit is displayed.
Press Select	SET TIME	Set the start time for each of four periods for the day displayed. Use the Up/Down buttons to set the start time for the period displayed. Wake is the default period. Pressing the "Next" button three times cycles through the period displayed (Wake, Day, Evening and Night).
Press Next	HEAT SETPOINT	Use the Up/Down arrows to set the Heat set point for the period displayed
Press Next	COOL SETPOINT	Use the Up/Down arrows to set the Heat set point for the period displayed
Press Next		Continue pressing Next and using up/down arrows until all Heat & Cool set points are set for the day displayed. After editing a start time or editing the set point temperature for one or more periods press "Done" to save edits. If "Done" is not pressed edits will not be saved.
After Pressing Done	Copy Schedule is displayed at the top of the screen. Yes and No buttons are displayed on the right side of the screen.	Press <u>yes to copy</u> or <u>no to return to Edit Schedule menu.</u>
Press Yes to Copy	COPY "___" To ___ is displayed at the top of the screen. Yes and No buttons are displayed on the right side of the screen.	Pressing Yes will copy the day displayed to the next day in the week. If Yes is pressed five more times the scheduled will be copied to the remaining 5 days in the week. To skip over a day and avoid copying the schedule to that day press No.
Press Done	EDIT SCHEDULE menu is displayed	To return to the Home Screen press "Done" one more time.
Press Done	Home Screen is displayed	
The schedule may be changed locally at the control with the Edit Schedule menu. If the 624 comfort control is connected to Nexia Home Intelligence the schedule may be changed remotely from the Nexia website using the websites Edit Schedule menu.		

User Guide

Scheduling

Copying Schedules

Press the following button sequence to access “Copying Schedules” from the Home Screen.

Copying Schedules		
Button Press	Menu Displayed	What Needs to Be Done?
Menu		
Next	USER SETTINGS screen	
Select	EDIT SCHEDULE screen	
Next	COPY SCHEDULE screen	
Select	COPY FROM screen (Mon)	Defaults to Monday
Next		Advances to next day
Back		Goes back to previous day
Select	Copy To screen	Select the day to copy to by pressing on Yes or No buttons until the copy to day is selected.
Press Done	COPY SCHEDULE	Continue copying one days schedule at a time to another or Press Done until the Home Screen Appears
Press Done	SCHEDULE	
Press Done	HOME SCREEN is displayed	
Press Done	Home Screen is displayed	

The schedule may be changed locally at the control with the Edit Schedule menu. If the 624 comfort control is connected to Nexia Home Intelligence the schedule may be changed remotely from the Nexia website using the websites Edit Schedule menu.

Edit Schedule (Remotely) - from Nexia Home Intelligence

Go to MyNexia.com, log into your account and select a TCONT624 comfort control from the Climate Page. Click on Edit Schedule and follow the online instructions. If you have not set up a Nexia Home Intelligence account go to MyNexia.com and click on “Get Started” to set up an account. A router and Nexia Bridge kit (SK101 - includes one Nexia Bridge and one Z-wave module) is required for remote access to the 624 control. For questions about connecting to Nexia Home Intelligence contact Nexia Home Intelligence Customer Service at 877-288-7707

Enroll Comfort Control into existing Z-Wave Network (Nexia™ Home Intelligence)

1 Prepare the bridge for enrollment. (Bridge kit SK101 purchased separately)

- Note: If the bridge is already installed, follow the instructions as they are written in the following steps. If the bridge is not installed, follow the instructions shipped with the bridge kit.
- a. Unplug Ethernet and power cables from bridge.
- b. Install a quality 9 volt battery.
- c. Verify that blue light is blinking. If blue light is solid, battery is dead.
- d. Take bridge to the location where the Comfort Control is mounted.

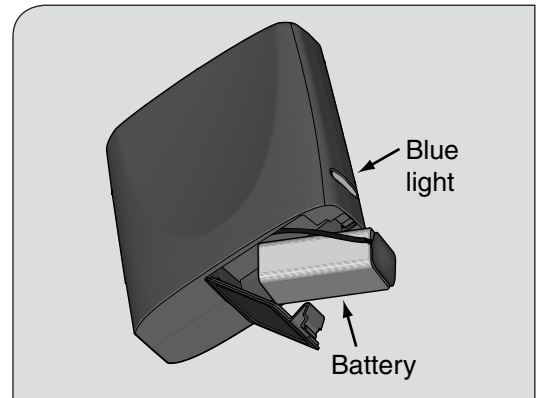

2 Enroll the Comfort Control into the bridge. (Inclusion)

If you are using a controller that is not a Nexia™ bridge, consult the instructions that shipped with the controller to find out how to enroll a new device.

- a. Hold the bridge within 6 feet (1.8 meters) of the Comfort Control throughout steps “b” through “f”.
 - After you begin the enrollment process, you have 30 seconds to complete the remainder of the steps. Study the steps below before beginning.
- b. Press and release the plus (+) button on the bridge.
- c. Press the MENU button on the Comfort Control.
- d. Press the NEXT button to advance to the Z-WAVE menu.
- e. Press SELECT
- f. Observe the lights on the bridge. The orange light will blink while enrollment is taking place. Enrollment is complete when the orange light becomes solid.

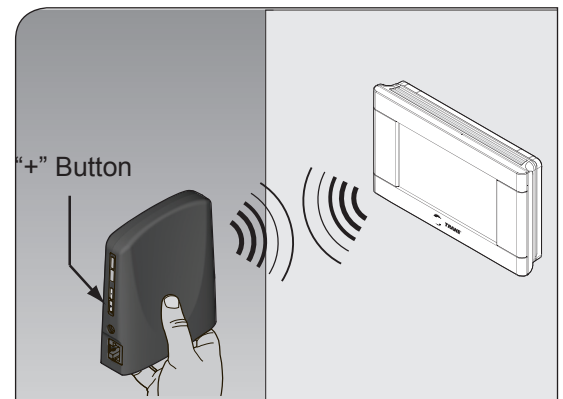

3 Verify enrollment of the Comfort Control.

- a. Press Menu Button on the main Comfort Control screen.
- b. Press the Next Button to advance to the About screen and press the Select Button.
- c. Press the Next Button to advance through the menu options to Node ID
 - If the number listed there is anything other than “00”, the Comfort Control has been successfully enrolled.
 - If the number listed there is “00”, the Comfort Control has NOT been successfully enrolled. In this case, repeat step 18 and verify again.
- d. Press Done button 2 times when finished.

Item	Description
VERSION 010000	Firmware version (number may vary)
ZWAVE VER 034006	Z-Wave version (number may vary)
NODE-ID 01	Z-Wave node ID (number may vary)
HOME-ID 00000000	Z-Wave Home ID (number may vary)
OUT-TYPE AC	Outdoor type may be AC, HP or NONE
C/O WITH COOL	Energize Reversing Valve with COOL or with HEAT (HP only)
IN-TYPE GAS/OIL	Indoor type may be GAS/OIL, ELECTRIC or HYDRONIC

Enroll Comfort Control into existing Z-Wave Network (Nexia™ Home Intelligence) Continued

4 Establish Online Connection to the Comfort Control.

Nexia Home Intelligence account must be active before continuing. See nexiahome.com for more information.

- a. Remove the battery from the bridge.
- b. Plug the Ethernet and power cord back into the bridge.
- c. Log into your account at www.mynexia.com
- d. Click the Climate tab and follow the on screen instructions.

Note: If the new thermostat icon remains gray or cannot be controlled remotely, you might need to add Z-wave repeaters to improve communications. Contact your local Nexia expert or call 877-288-7707 for assistance.

Un-enroll Comfort Control from existing Z-Wave Network (Nexia™ Home Intelligence)

1 If you need to remove the 624 from a Nexia Home Intelligence account, follow the Exclusion steps. This will delete the ability to control the thermostat remotely. If you are unsure, please contact Nexia support at 877-288-7707.

Install a new, high-quality 9-volt battery into the bridge.

- a. Hold the bridge within 6 feet (1.8 meters) of the Comfort Control throughout the entire exclusion process.
 - ➔ After you begin the exclusion process, you have 30 seconds to complete the remainder of the steps. Study the steps below before beginning.
- b. Press and release the minus (-) button on the bridge.
- c. Press the **MENU** button on the Comfort Control.
- d. Press NEXT button to scroll to Z-WAVE screen then press SELECT.
- e. Press the **Yes** button to exclude the Comfort Control.
- f. Observe the lights on the bridge. The orange light will blink while exclusion is taking place. Exclusion is complete when the orange light becomes solid.
 - ➔ Z-Wave™ controllers from various manufacturers may support the Z-Wave™ Thermostat General V2 Device class used by the Z-Wave™ Comfort Control. If you are using a controller that is not a Nexia bridge, consult the instructions that came with the controller to find out how to enroll a new device.

Firmware Upgrades

1

Firmware Upgrades allow the user to update the 624 control. Upgrades may take up to 45 minutes. The system operation will be maintained during the upgrade process. To access the Firmware Upgrades navigate to mynexia.com and look for the Edit Home screen button. The Edit Home screen button is located about mid way down the Nexia Home Page.



- a. On the Edit Home, Firmware Updates page, the 624 will appear. If a firmware update is available an "Update Firmware" button will appear.

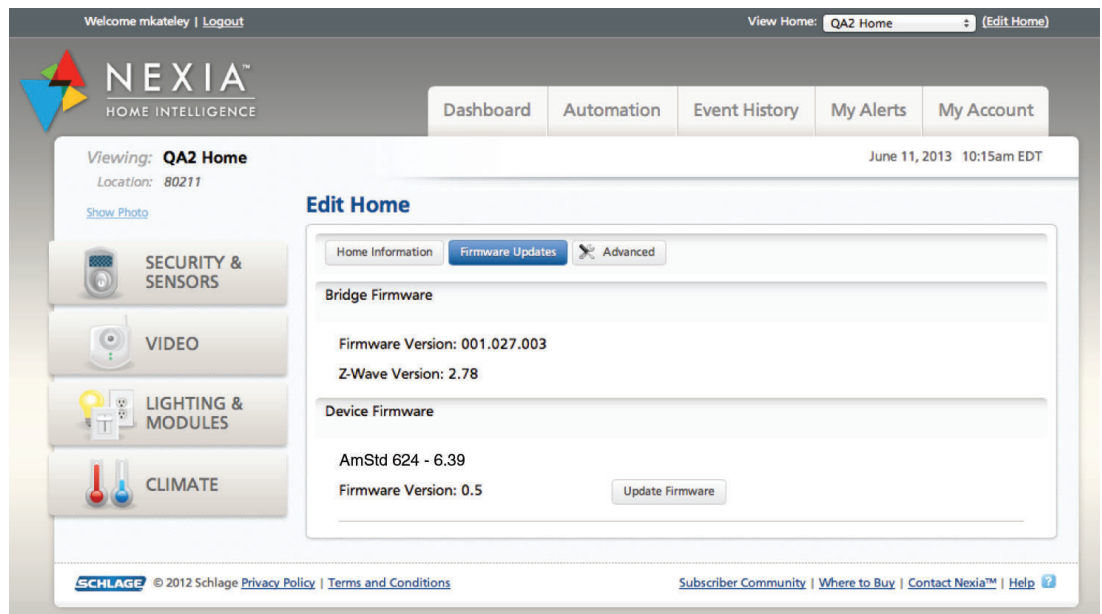

User Guide

- b. When the user selects the “Update Firmware” button an “Update Firmware” dialog will appear. The dialog will first connect to the device and then it will display the firmware update progress.

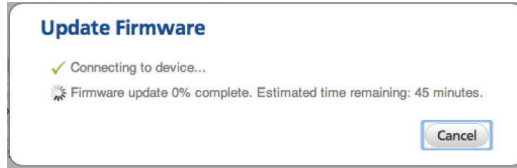

- c. After the firmware has been downloaded it is then applied to the TCONT624.

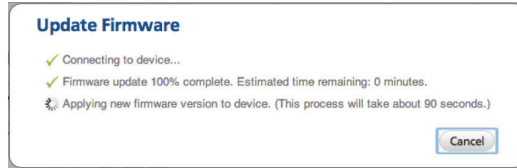

- d. The portal retrieves version information from the TCONT624.

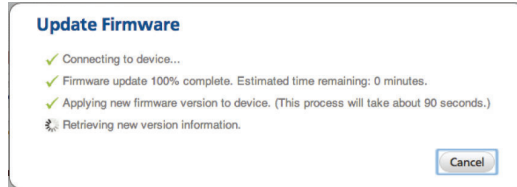

- e. Finally the user is shown that the firmware was updated successfully



About

About	
Setting	Range
Version	Current firmware version loaded on the control
ZWAVE Ver	Current version of the ZWAVE firmware
Node - ID	ZWAVE identification for this device
Home - ID	ZWAVE identification for the connected ZWAVE network
Out - Type	Identifies the type of outdoor unit installed
C/O - Type	Indicates whether the switchover valve (SOV) is energized in cooling or heating mode
In - Type	Identifies the type of indoor unit installed

Once all selections have been made, press the Done button to exit and return to Menu. Press Next to navigate to the next setting.

Clean Screen

Clean Screen		
Setting	Range	Description
Clean Screen	Yes, No	Selecting yes allows the user to clean the screen without activating any of the onscreen touch points. Use only water and a soft cloth, no harmful chemicals.

Once all selections have been made, press the Done button to exit and return to Menu. Press Next to navigate to the next setting.

Installer's Guide

Product Specifications

Specification	Description
Product Model:	TCONT624AS42DAA
Product:	HVAC System comfort control. Z-Wave™ RF communications enabled
Size:	5.75" wide x 3.5" height x 1" depth
Display:	Fixed Segment LCD, 4" x 2.25", with 17 character alpha numeric display
Touchscreen:	Yes.
Backlight:	Yes, White, Controllable, on, off, timeout
Power:	24VAC from HVAC System
HVAC System Type:	Standard (gas/electric), Heat Pump, or Dual Fuel
Heat/Cool Stages:	Up to four stages of heat/two stages cool
PWM Output (BK)	Proprietary Variable speed motor control
Heat Pump Switchover valve:	Selectable change over with cool or with heat
Auxiliary Contact	Humidifier, Ventilation or Dehumidifier control
Communications:	Z-Wave™ RF
Memory:	Non-volatile
Date/Time:	24 hour super capacitor backup Time is automatically updated if the control is connected to NEXIA home intelligence

Installation and Wiring

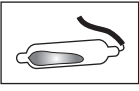

MERCURY NOTICE

When this Comfort Control is replacing an old thermostat that contains mercury in a sealed tube, do not dispose of your old thermostat in the trash. Dispose of properly. Contact your local waste management authority for instructions regarding recycling and proper disposal of the old thermostat.

A listing of heating, ventilating and air conditioning wholesalers that participate in the Thermostat Recycling Corporation's recycling program are available at www.thermostat-recycle.org.

Physical Location

Temperature Sensing Considerations

The 624 Control is designed for installation in climate controlled living spaces. It is recommended to place the unit in central locations with good circulation. Avoid exterior walls and areas near windows, doors, vents or concealed pipes or chimneys.

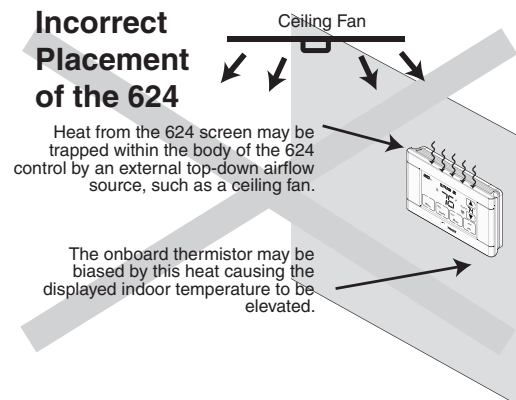
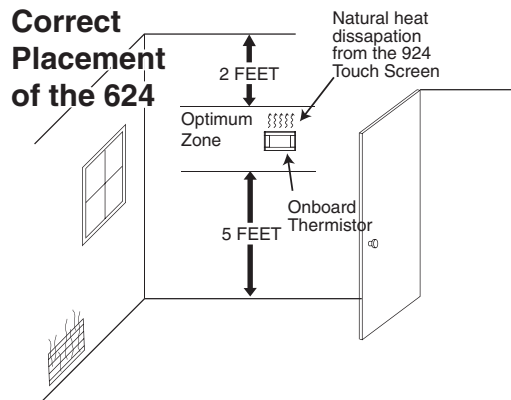

Installer's Guide

Field Wiring Diagrams

Heat/Cool Wiring Diagrams

Heat/Cool Diagram 1: 1 or 2 Stage Cooling w/TAM7 Model Variable Speed Air Handler

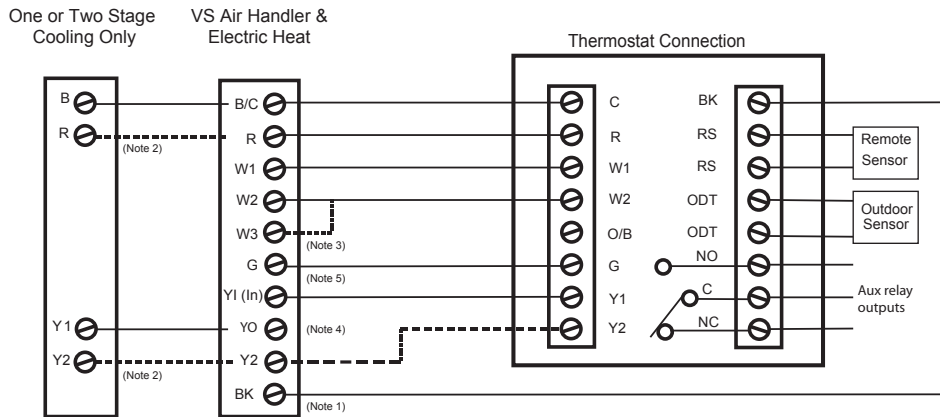

Notes:

1. Cut/remove the factory installed "BK" jumper at the indoor unit
2. "Y2" & "R" connections at outdoor are only required for two stage units
3. Jumper "W2" to "W3" if three stages of indoor heat is available
4. "Y1" and "YO" connections must be made as shown for freeze protection and internally mounted condensate overflow circuits to work properly
5. If third party condensate overflow switched are installed, they should be wired between "Y1" of the thermostat and "Y1" of the airflow control board

Remote Temperature Sensor Connections and Operation:

Sensor Options in the Installer Settings/Sensor Settings menu
 Remote Sensor (connect to the RS terminals)
 - None
 - Replaces internal sensor
 - Average with internal sensor
 Outdoor Temp Sensor (connect to the ODT terminals)
 - None
 - Outdoor
 Caution: Do not run sensor wires in the same bundle with HVAC wires. Keep away from high voltage wiring to avoid interference.

Heat/Cool Diagram 2: 1 Stage Cooling w/"GAM5A" & "TAM4" Model Air Handler

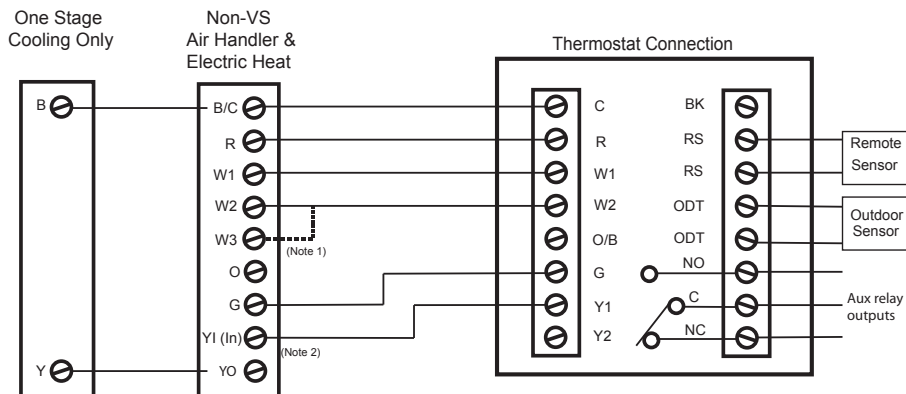

Notes:

1. Jumper "W2" to "W3" if three stages of indoor heat is available
2. "Y1" and "YO" connections must be made as shown for freeze protection and internally mounted condensate overflow circuits to work properly
3. If third party condensate overflow switched are installed, they should be wired between "Y" of the thermostat and "Y1" of the airflow control board

Remote Temperature Sensor Connections and Operation:

Sensor Options in the Installer Settings/Sensor Settings menu
 Remote Sensor (connect to the RS terminals)
 - None
 - Replaces internal sensor
 - Average with internal sensor
 Outdoor Temp Sensor (connect to the ODT terminals)
 - None
 - Outdoor
 Caution: Do not run sensor wires in the same bundle with HVAC wires. Keep away from high voltage wiring to avoid interference.

Installer's Guide

Heat/Cool Wiring Diagrams

Heat/Cool Diagram 3: 1 Stage Cooling w/"GAM5B" Model Air Handler

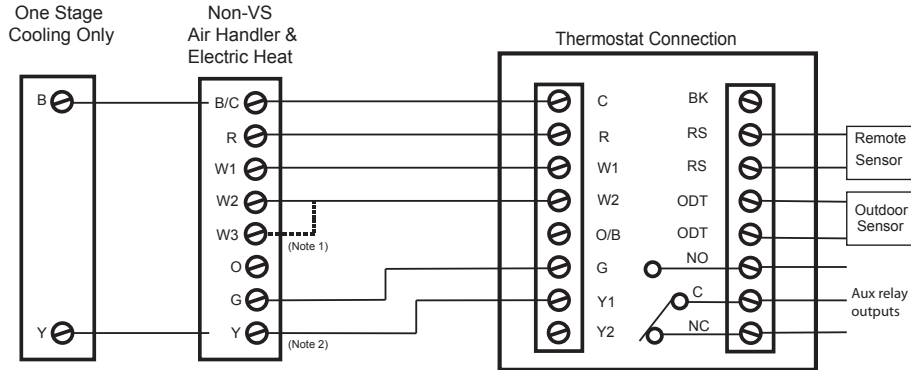

Notes:

1. Jumper "W2" to "W3" if three stages of indoor heat is available
2. "Y" terminal must be connected at indoor unit for high stage airflow.

Remote Temperature Sensor Connections and Operation:

Sensor Options in the Installer Settings/Sensor Settings menu
 Remote Sensor (connect to the RS terminals)
 - None
 - Replaces internal sensor
 - Average with internal sensor
 Outdoor Temp Sensor (connect to the ODT terminals)
 - None
 - Outdoor
 Caution: Do not run sensor wires in the same bundle with HVAC wires. Keep away from high voltage wiring to avoid interference.

Heat/Cool Diagram 4: 2 Step Cooling w/"GAM5B" Model Air Handler

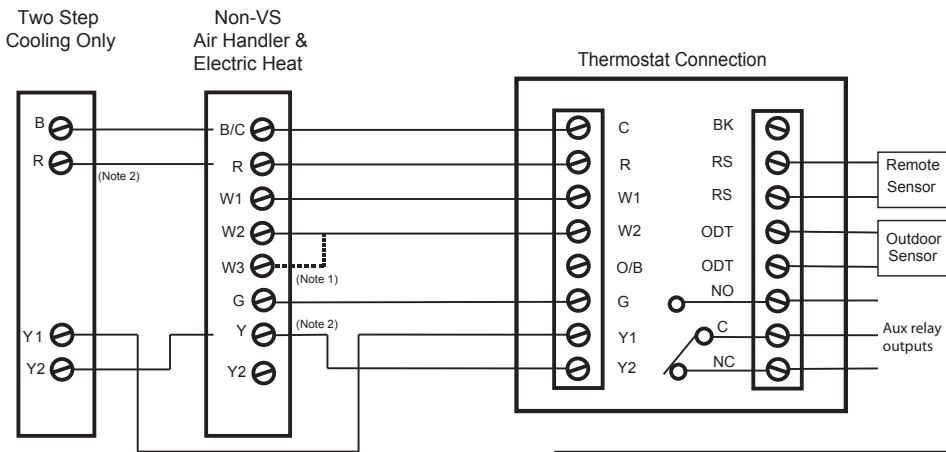

Notes:

1. Jumper "W2" to "W3" if three stages of indoor heat is available
2. "Y" must be connected at indoor unit for high stage airflow

Remote Temperature Sensor Connections and Operation:

Sensor Options in the Installer Settings/Sensor Settings menu
 Remote Sensor (connect to the RS terminals)
 - None
 - Replaces internal sensor
 - Average with internal sensor
 Outdoor Temp Sensor (connect to the ODT terminals)
 - None
 - Outdoor
 Caution: Do not run sensor wires in the same bundle with HVAC wires. Keep away from high voltage wiring to avoid interference.

Installer's Guide

Heat/Cool Wiring Diagrams

Heat/Cool Diagram 5: 1 Stage Cooling w/"GAF2-S" Model Air Handler

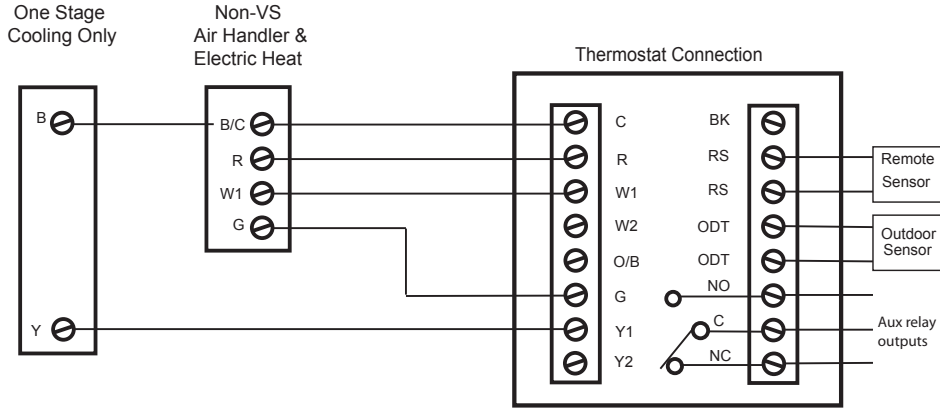

Remote Temperature Sensor Connections and Operation:

Sensor Options in the Installer Settings/Sensor Settings menu
 Remote Sensor (connect to the RS terminals)
 - None
 - Replaces internal sensor
 - Average with internal sensor
 Outdoor Temp Sensor (connect to the ODT terminals)
 - None
 - Outdoor
 Caution: Do not run sensor wires in the same bundle with HVAC wires. Keep away from high voltage wiring to avoid interference.

Heat/Cool Diagram 6: 1 stage cooling w/"GAF2-36M" Model Air Handler

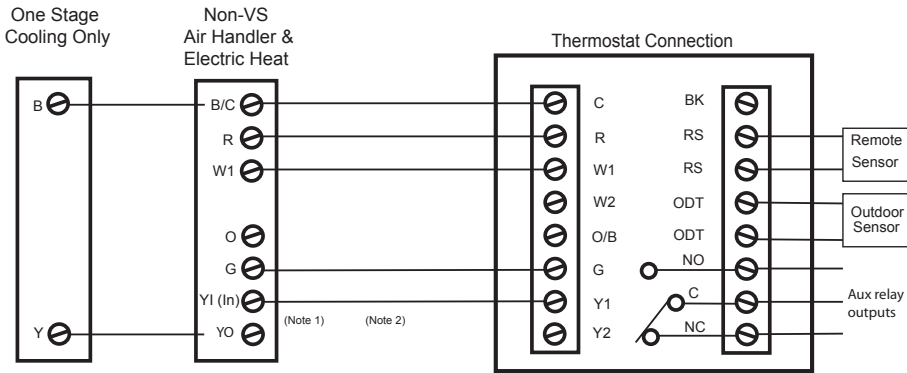

Notes:

- "Y1" and "YO" connections must be made as shown for freeze protection and internally mounted condensate overflow circuits to work properly
- If third party condensate overflow switched are installed, they should be wired between "Y1" of the thermostat and "Y1" of the airflow control board

Remote Temperature Sensor Connections and Operation:

Sensor Options in the Installer Settings/Sensor Settings menu
 Remote Sensor (connect to the RS terminals)
 - None
 - Replaces internal sensor
 - Average with internal sensor
 Outdoor Temp Sensor (connect to the ODT terminals)
 - None
 - Outdoor
 Caution: Do not run sensor wires in the same bundle with HVAC wires. Keep away from high voltage wiring to avoid interference.

Installer's Guide

Heat/Cool Wiring Diagrams

Heat/Cool Diagram 7: 1 Stage Cooling w/"GAT2" & "GAM2" Model Air Handlers

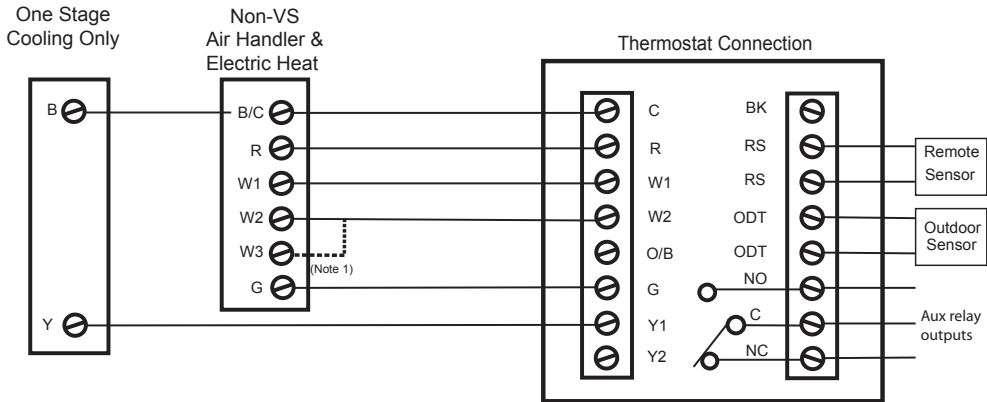

Notes:

1. Jumper "W2" to "W3" if three stages of indoor heat is available

Remote Temperature Sensor Connections and Operation:

Sensor Options in the Installer Settings/Sensor Settings menu

Remote Sensor (connect to the RS terminals)

- None
 - Replaces internal sensor
 - Average with internal sensor
- Outdoor Temp Sensor (connect to the ODT terminals)
- None
 - Outdoor

Caution: Do not run sensor wires in the same bundle with HVAC wires. Keep away from high voltage wiring to avoid interference.

Heat/Cool Diagram 8: 1 Stage Cooling w/"TEM3" Model Air Handler

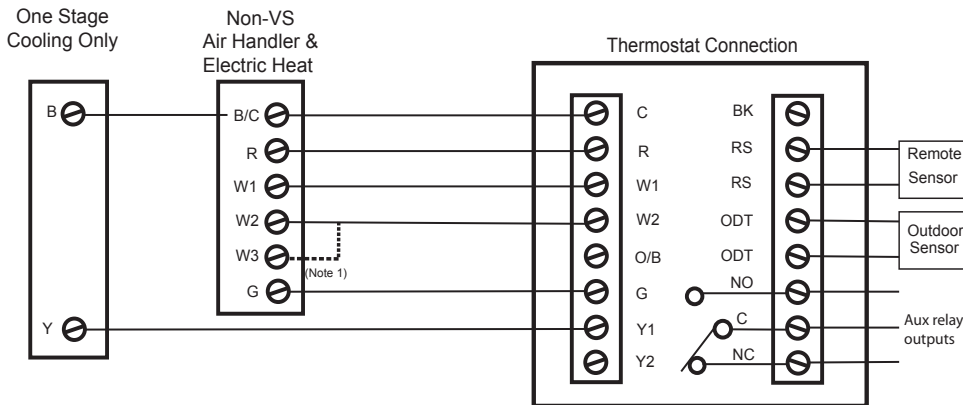

Notes:

1. Jumper "W2" to "W3" if three stages of indoor heat is available

Remote Temperature Sensor Connections and Operation:

Sensor Options in the Installer Settings/Sensor Settings menu

Remote Sensor (connect to the RS terminals)

- None
 - Replaces internal sensor
 - Average with internal sensor
- Outdoor Temp Sensor (connect to the ODT terminals)
- None
 - Outdoor

Caution: Do not run sensor wires in the same bundle with HVAC wires. Keep away from high voltage wiring to avoid interference.

Installer's Guide

Heat/Cool Wiring Diagrams

Heat/Cool Diagram 9: 1 or 2 Stage Cooling w/non-TAM7 Model Variable Speed Air Handler

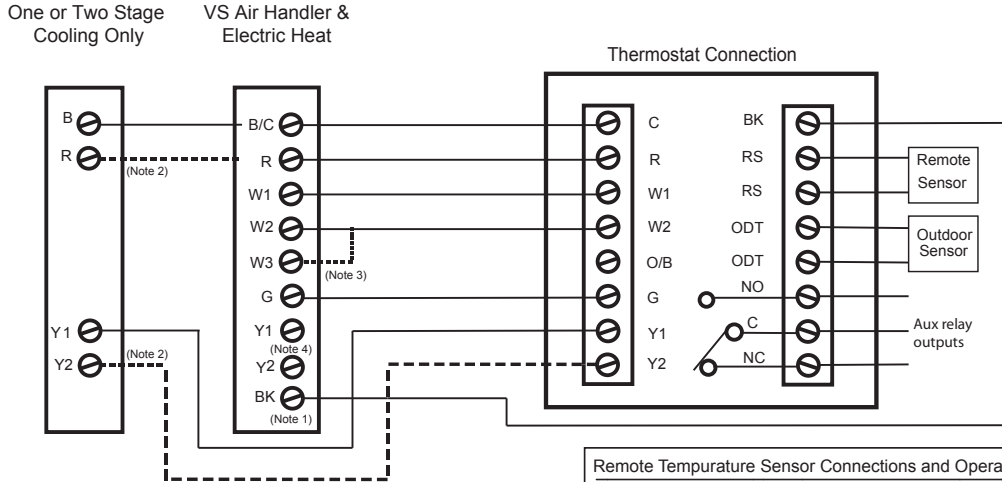

Notes:

1. Cut/remove the factory installed "BK" jumper at the indoor unit
2. "Y2" & "R" connections at outdoor are only required for two stage units
3. Jumper "W2" to "W3" if three stages of indoor heat is available
4. For non-Trane/American Standard Indoor units "BK" is not connected and "Y1"/"Y2" must be connected at indoor unit.

Heat/Cool Diagram 10: 1 Stage Cooling w/non-variable Speed Air Handler (Excludes Hyperion/Forefront/TEM3 Air Handlers)

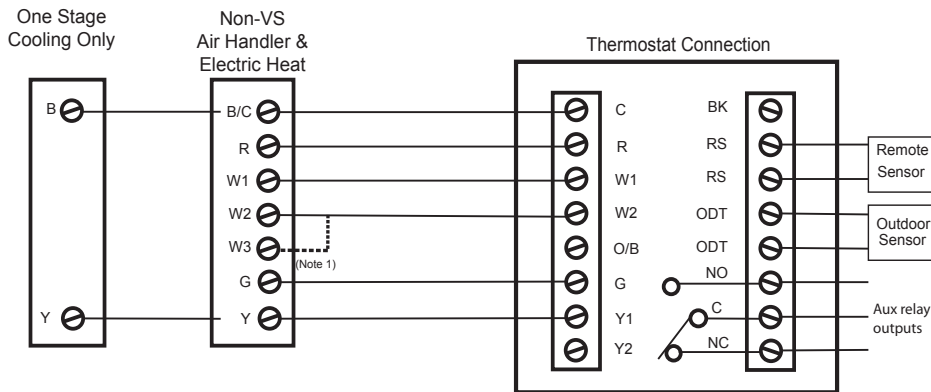

Notes:

1. Jumper "W2" to "W3" if three stages of indoor heat is available

Remote Temperature Sensor Connections and Operation:

Sensor Options in the Installer Settings/Sensor Settings menu

Remote Sensor (connect to the RS terminals)

- None
- Replaces internal sensor
- Average with internal sensor

Outdoor Temp Sensor (connect to the ODT terminals)

- None
- Outdoor

Caution: Do not run sensor wires in the same bundle with HVAC wires. Keep away from high voltage wiring to avoid interference.

Installer's Guide

Heat/Cool Wiring Diagrams

Heat/Cool Diagram 11: 1 Stage Cooling w/non-Variable Speed Gas Furnace

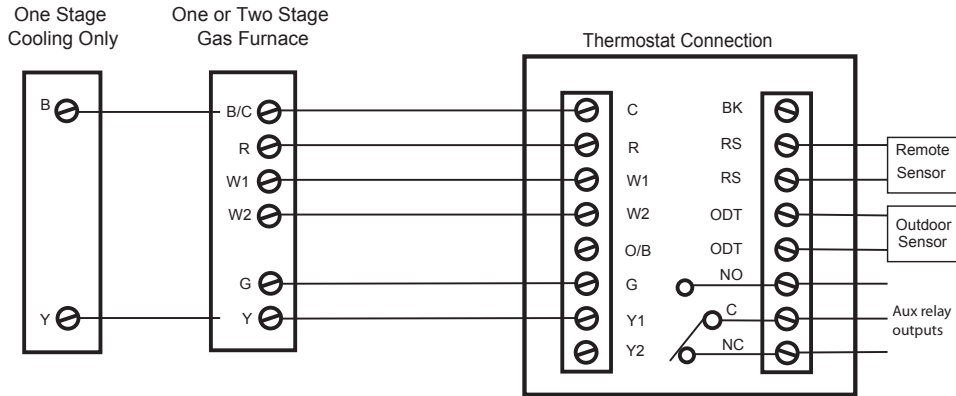

Remote Temperature Sensor Connections and Operation:

Sensor Options in the Installer Settings/Sensor Settings menu
 Remote Sensor (connect to the RS terminals)

- None
- Replaces internal sensor
- Average with internal sensor

Outdoor Temp Sensor (connect to the ODT terminals)

- None
- Outdoor

Caution: Do not run sensor wires in the same bundle with HVAC wires. Keep away from high voltage wiring to avoid interference.

Heat/Cool Diagram 12: 1 or 2 Stage Cooling w/Variable Speed Gas Furnace

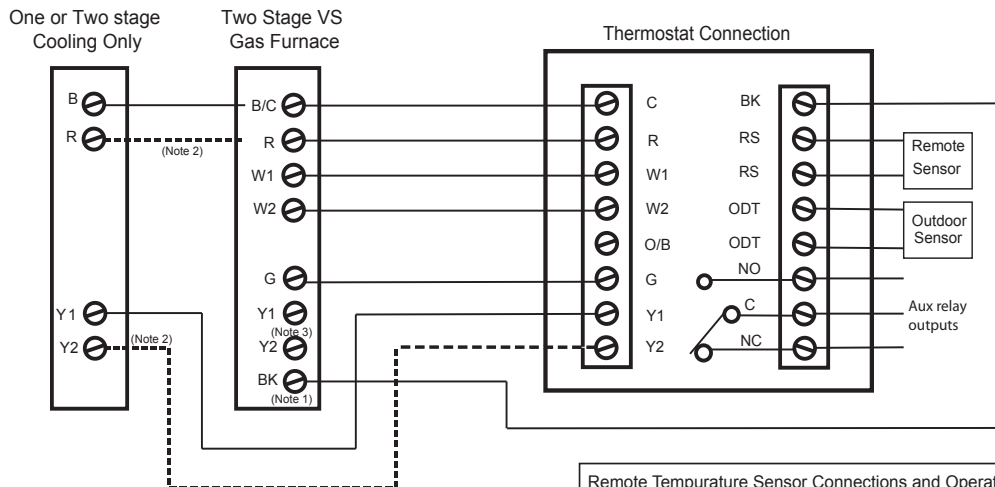

- Notes:
1. Cut/remove the factory installed "BK" jumper at the indoor unit
 2. "Y2" & "R" connections at outdoor are only required for two stage units
 3. For non-Trane/American Standard Indoor units "BK" is not connected and "Y1"/"Y2" must be connected at indoor unit.

Remote Temperature Sensor Connections and Operation:

Sensor Options in the Installer Settings/Sensor Settings menu
 Remote Sensor (connect to the RS terminals)

- None
- Replaces internal sensor
- Average with internal sensor

Outdoor Temp Sensor (connect to the ODT terminals)

- None
- Outdoor

Caution: Do not run sensor wires in the same bundle with HVAC wires. Keep away from high voltage wiring to avoid interference.

Installer's Guide

Heat/Cool Wiring Diagrams

Heat/Cool Diagram 13: 1 Stage Cooling w/non-Variable Speed Oil Furnace

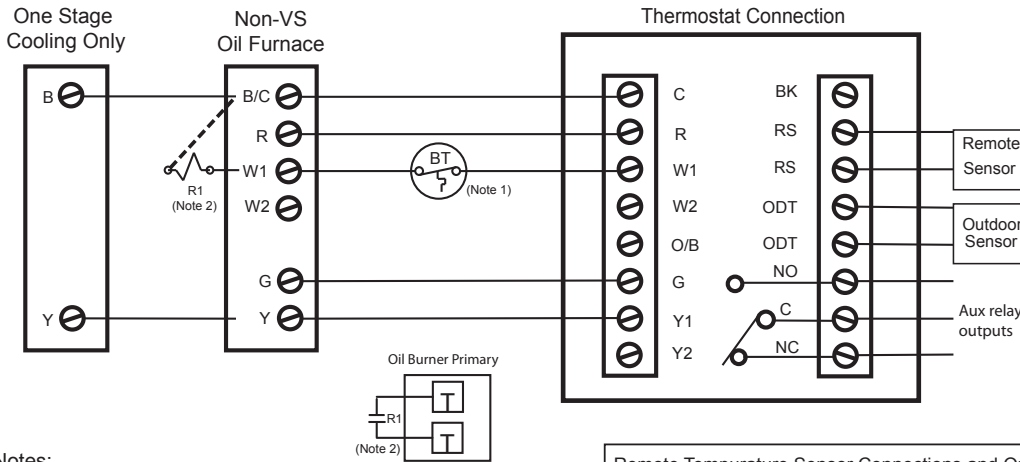

Notes:

1. BT (Bonnet Thermostat) model THT1248 (BAYSEN03ATEMPAA) required for dual fuel, oil furnace applications.
2. Field supplied relay (R1) required for oil burner primary

Remote Temperature Sensor Connections and Operation:

- Sensor Options in the Installer Settings/Sensor Settings menu
- Remote Sensor (connect to the RS terminals)
- None
 - Replaces internal sensor
 - Average with internal sensor
- Outdoor Sensor (connect to the ODT terminals)
- None
 - Outdoor
- Caution: Do not run sensor wires in the same bundle with HVAC wires. Keep away from high voltage wiring to avoid interference.

Heat/Cool Diagram 14: 1 or 2 Stage Cooling w/Variable Speed Oil Furnace

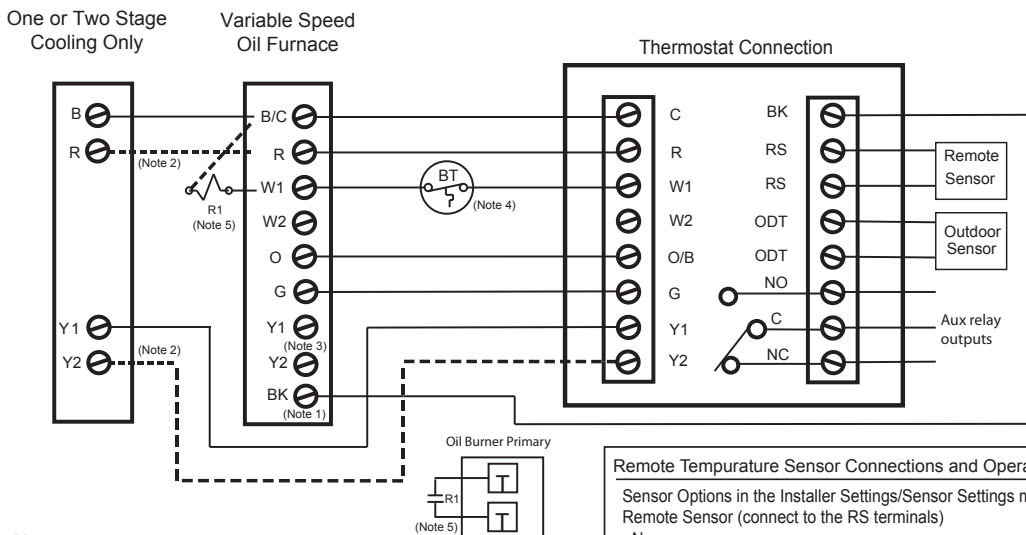

Notes:

1. Cut/remove the factory installed "BK" jumper at the indoor unit
2. "Y2" & "R" connections at outdoor unit are only required for 2 stage systems
3. For non-Trane/American Standard Indoor units "BK" is not connected and "Y1"/"Y2" must be connected at indoor unit.
4. BT (Bonnet Thermostat) model THT1248 BAYSEN03ATEMPAA) required for dual fuel, oil furnace applications
5. Field supplied relay (R1) required for oil burner primary

Remote Temperature Sensor Connections and Operation:

- Sensor Options in the Installer Settings/Sensor Settings menu
- Remote Sensor (connect to the RS terminals)
- None
 - Replaces internal sensor
 - Average with internal sensor
- Outdoor Temp Sensor (connect to the ODT terminals)
- None
 - Outdoor
- Caution: Do not run sensor wires in the same bundle with HVAC wires. Keep away from high voltage wiring to avoid interference.

Installer's Guide

Heat/Cool Wiring Diagrams

Heat/Cool Diagram 15: Package Single or Multi-Stage Gas/Electric with Variable Speed Blower

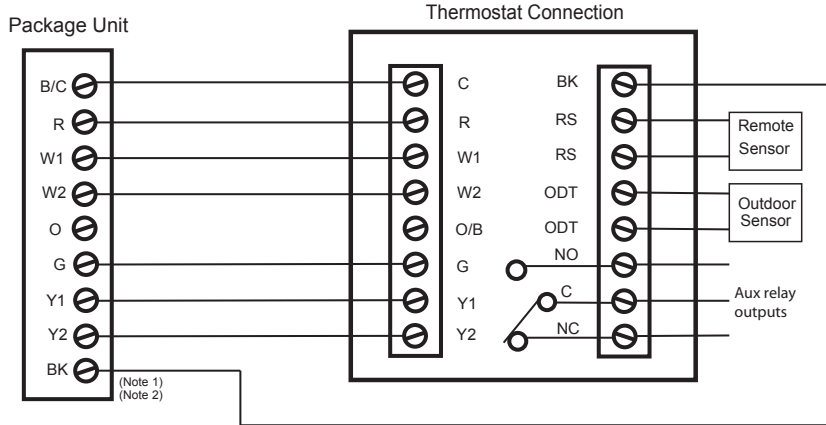

- Notes:
1. Cut/remove the factory installed "BK" jumper on the ECM fan control board
 2. For non-Trane/American Standard Indoor units "BK" is not connected

Remote Temperature Sensor Connections and Operation:

Sensor Options in the Installer Settings/Sensor Settings menu

Remote Sensor (connect to the RS terminals)

- None
- Replaces internal sensor
- Average with internal sensor

Outdoor Temp Sensor (connect to the ODT terminals)

- None
- Outdoor

Caution: Do not run sensor wires in the same bundle with HVAC wires. Keep away from high voltage wiring to avoid interference.

Heat/Cool Diagram 16: Package Single Stage Gas/Electric with non-Variable Speed Blower

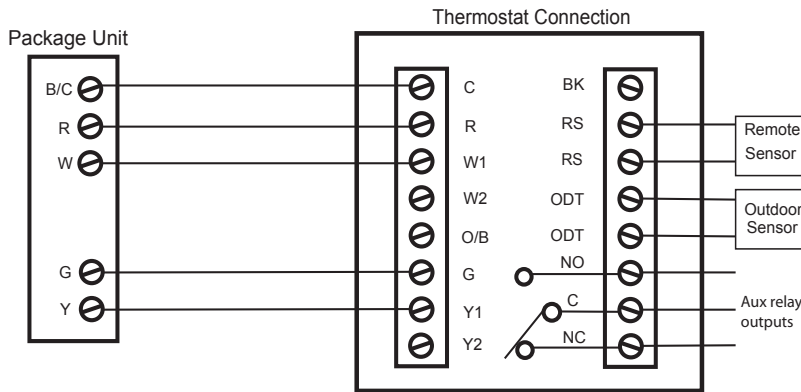

Remote Temperature Sensor Connections and Operation:

Sensor Options in the Installer Settings/Sensor Settings menu

Remote Sensor (connect to the RS terminals)

- None
- Replaces internal sensor
- Average with internal sensor

Outdoor Temp Sensor (connect to the ODT terminals)

- None
- Outdoor

Caution: Do not run sensor wires in the same bundle with HVAC wires. Keep away from high voltage wiring to avoid interference.

Installer's Guide

Heat Pump Wiring Diagrams

Heat Pump Diagram 1: 1 or 2 Stage Heat Pump w/TAM7 Model Variable Speed Air Handler

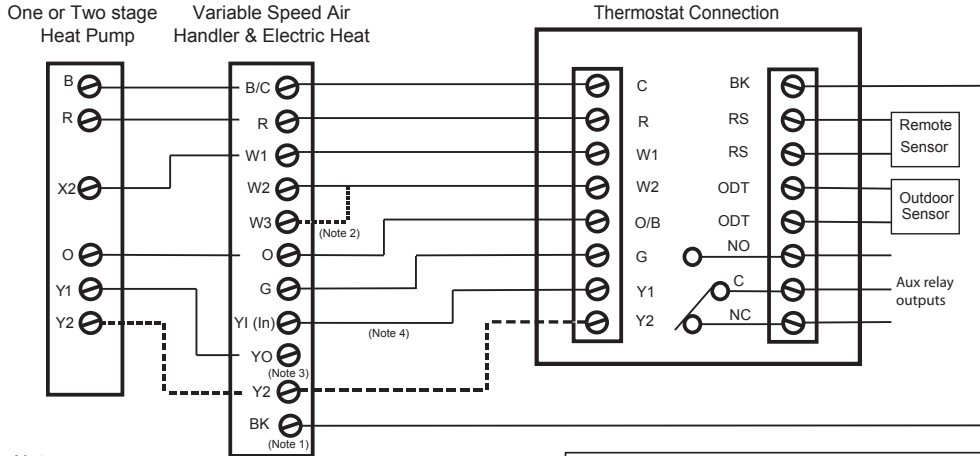

Notes:

1. Cut/remove the factory installed "BK" jumper at the indoor unit
2. Jumper "W2" to "W3" if three stages of indoor heat is available
3. "Y1" and "YO" connections must be made as shown for freeze protection and internally mounted condensate overflow circuits to work properly
4. If 3rd party condensate overflow switches are installed, they should be wired between "Y1" of the thermostat and "Y1" of the airflow control board

Remote Temperature Sensor Connections and Operation:

Sensor Options in the Installer Settings/Sensor Settings menu

Remote Sensor (connect to the RS terminals)

- None
- Replaces internal sensor
- Average with internal sensor

Outdoor Temp Sensor (connect to the ODT terminals)

- None
- Outdoor

Caution: Do not run sensor wires in the same bundle with HVAC wires. Keep away from high voltage wiring to avoid interference.

Heat Pump Diagram 2: 1 Stage Heat Pump w/"GAM5A" & "TAM4" Model Air Handler

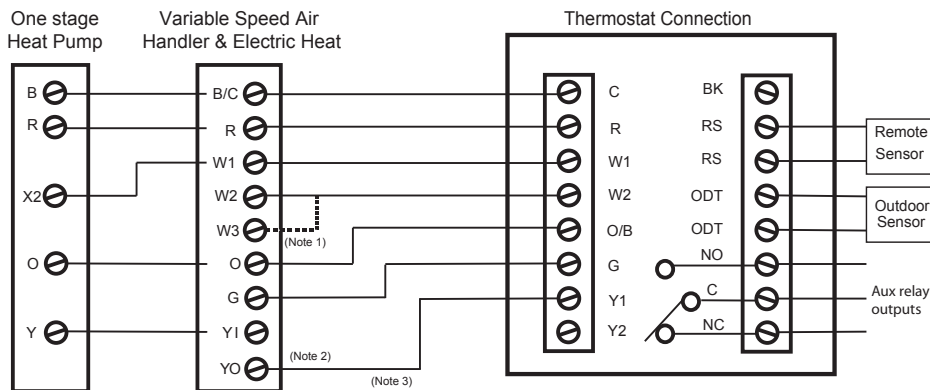

Notes:

1. Jumper "W2" to "W3" if three stages of indoor heat is available
2. "Y1" and "YO" connections must be made as shown for freeze protection and internally mounted condensate overflow circuits to work properly.
3. If 3rd party condensate overflow switches are installed, they should be wired between "Y" of the thermostat and "Y1" of the airflow control board.

Remote Temperature Sensor Connections and Operation:

Sensor Options in the Installer Settings/Sensor Settings menu

Remote Sensor (connect to the RS terminals)

- None
- Replaces internal sensor
- Average with internal sensor

Outdoor Temp Sensor (connect to the ODT terminals)

- None
- Outdoor

Caution: Do not run sensor wires in the same bundle with HVAC wires. Keep away from high voltage wiring to avoid interference.

Installer's Guide

Heat Pump Wiring Diagrams

Heat Pump Diagram 3: 1 Stage Heat Pump w/"GAM5B" Model Air Handler

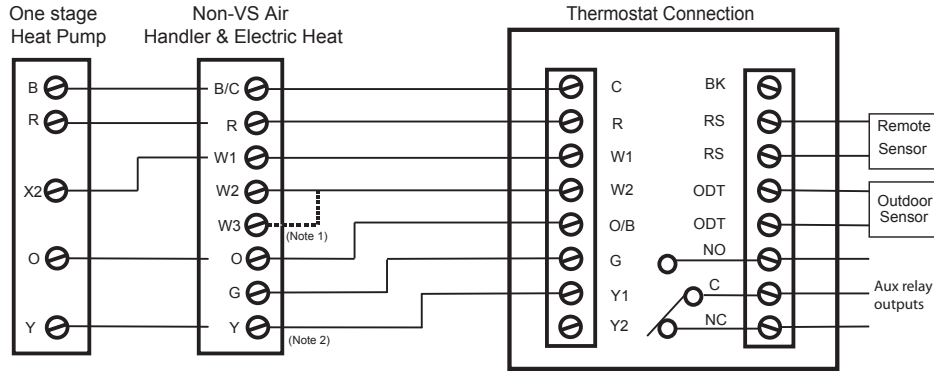

Notes:

1. Jumper "W2" to "W3" if three stages of indoor heat is available
2. "Y" terminal must be connected at indoor unit for high stage air flow

Remote Temperature Sensor Connections and Operation:

Sensor Options in the Installer Settings/Sensor Settings menu
 Remote Sensor (connect to the RS terminals)
 - None
 - Replaces internal sensor
 - Average with internal sensor
 Outdoor Temp Sensor (connect to the ODT terminals)
 - None
 - Outdoor
 Caution: Do not run sensor wires in the same bundle with HVAC wires. Keep away from high voltage wiring to avoid interference.

Heat Pump Diagram 4: 2 Step Heat Pump w/"GAM5B" Model Air Handler

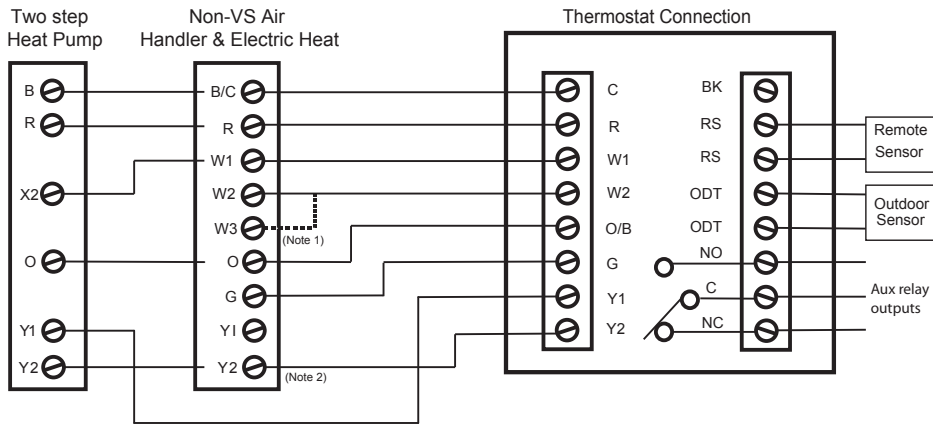

Notes:

1. Jumper "W2" to "W3" if three stages of indoor heat is available
2. "Y2" terminal must be connected at indoor unit for high stage air flow

Remote Temperature Sensor Connections and Operation:

Sensor Options in the Installer Settings/Sensor Settings menu
 Remote Sensor (connect to the RS terminals)
 - None
 - Replaces internal sensor
 - Average with internal sensor
 Outdoor Temp Sensor (connect to the ODT terminals)
 - None
 - Outdoor
 Caution: Do not run sensor wires in the same bundle with HVAC wires. Keep away from high voltage wiring to avoid interference.

Installer's Guide

Heat Pump Wiring Diagrams

Heat Pump Diagram 5: 1 Stage Heat Pump w/"GAF2-S" Model Air Handler

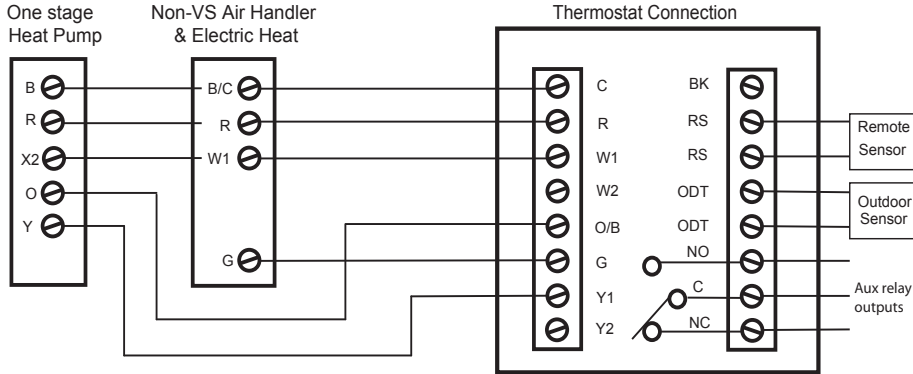

Remote Temperature Sensor Connections and Operation:
 Sensor Options in the Installer Settings/Sensor Settings menu
 Remote Sensor (connect to the RS terminals)
 - None
 - Replaces internal sensor
 - Average with internal sensor
 Outdoor Temp Sensor (connect to the ODT terminals)
 - None
 - Outdoor
 Caution: Do not run sensor wires in the same bundle with HVAC wires. Keep away from high voltage wiring to avoid interference.

Heat Pump Diagram 6: 1 Stage Heat Pump w/"GAF2-36M" Model Air Handler

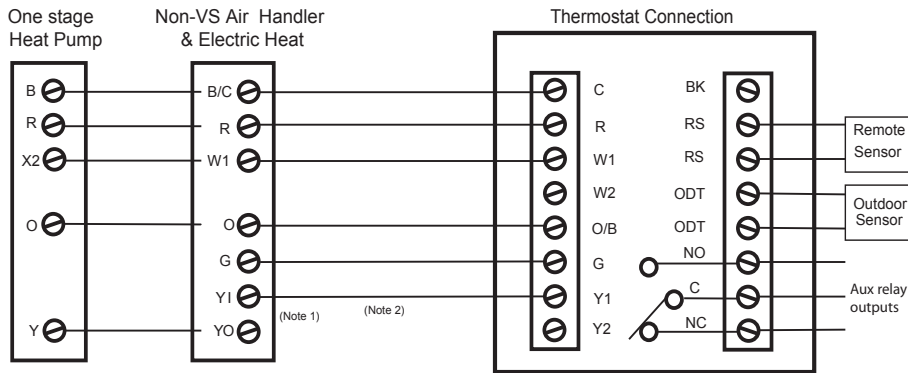

Notes:
 1. "YI" and "YO" connections must be made as shown for freeze protection and internally mounted condensate overflow circuits to work properly
 2. If 3rd party condensate overflow switches are installed, they should be wired between "Y" of the thermostat and "YI" of the airflow control board

Remote Temperature Sensor Connections and Operation:
 Sensor Options in the Installer Settings/Sensor Settings menu
 Remote Sensor (connect to the RS terminals)
 - None
 - Replaces internal sensor
 - Average with internal sensor
 Outdoor Temp Sensor (connect to the ODT terminals)
 - None
 - Outdoor
 Caution: Do not run sensor wires in the same bundle with HVAC wires. Keep away from high voltage wiring to avoid interference.

Installer's Guide

Heat Pump Wiring Diagrams

Heat Pump Diagram 7: 1 Stage Heat Pump w/"GAT2" & "GAM2" Model Air Handler

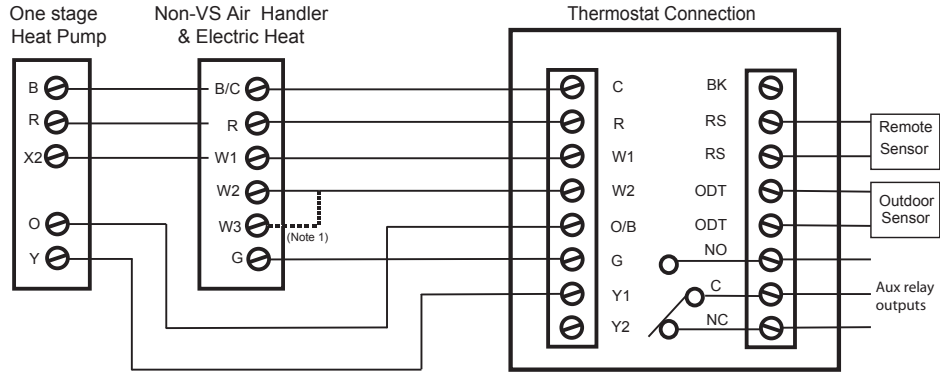

Notes:

1. Jumper "W2" to "W3" if three stages of indoor heat is available

Remote Temperature Sensor Connections and Operation:

- Sensor Options in the Installer Settings/Sensor Settings menu
- Remote Sensor (connect to the RS terminals)
- None
 - Replaces internal sensor
 - Average with internal sensor
- Outdoor Temp Sensor (connect to the ODT terminals)
- None
 - Outdoor
- Caution: Do not run sensor wires in the same bundle with HVAC wires. Keep away from high voltage wiring to avoid interference.

Heat Pump Diagram 8: 1 Stage Heat Pump w/"TEM3" Model Air Handler

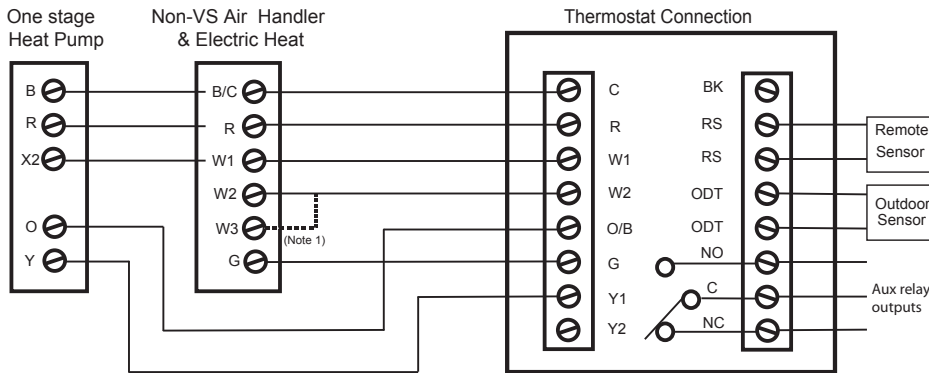

Notes:

1. Jumper "W2" to "W3" if three stages of indoor heat is available

Remote Temperature Sensor Connections and Operation:

- Sensor Options in the Installer Settings/Sensor Settings menu
- Remote Sensor (connect to the RS terminals)
- None
 - Replaces internal sensor
 - Average with internal sensor
- Outdoor Temp Sensor (connect to the ODT terminals)
- None
 - Outdoor
- Caution: Do not run sensor wires in the same bundle with HVAC wires. Keep away from high voltage wiring to avoid interference.

Installer's Guide

Heat Pump Wiring Diagrams

Heat Pump Diagram 9: 1 or 2 Stage Heat Pump w/non-TAM7 Model Variable Speed Air Handler

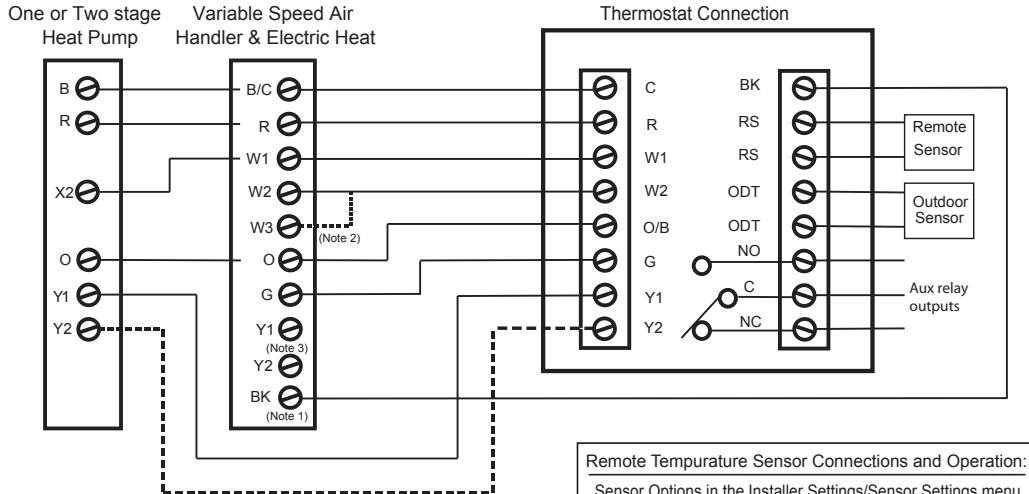

- Notes:
1. Cut/remove the factory installed "BK" jumper at the indoor unit
 2. Jumper "W2" to "W3" if three stages of indoor heat is available
 3. For non-Trane/American Standar indoor units "BK" is not connected and the "Y1"/"Y2" must be connected at indoor unit

Remote Temperature Sensor Connections and Operation:

- Sensor Options in the Installer Settings/Sensor Settings menu
- Remote Sensor (connect to the RS terminals)
- None
 - Replaces internal sensor
 - Average with internal sensor
- Outdoor Temp Sensor (connect to the ODT terminals)
- None
 - Outdoor
- Caution: Do not run sensor wires in the same bundle with HVAC wires. Keep away from high voltage wiring to avoid interference.

Heat Pump Diagram 10: 1 Stage Heat Pump w/non-Variable Speed Air Handler (Excludes Hyperion/Forefront/TEM3 Air Handlers)

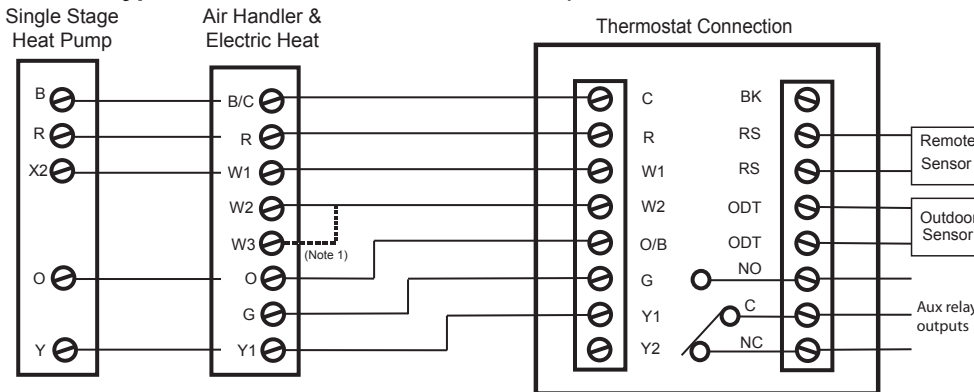

- Notes:
1. Jumper "W2" to "W3" if three stages of indoor heat is available.

Remote Temperature Sensor Connections and Operation:

- Sensor Options in the Installer Settings/Sensor Settings menu
- Remote Sensor (connect to the RS terminals)
- None
 - Replaces internal sensor
 - Average with internal sensor
- Outdoor Temp Sensor (connect to the ODT terminals)
- None
 - Outdoor
- Caution: Do not run sensor wires in the same bundle with HVAC wires. Keep away from high voltage wiring to avoid interference.

Installer's Guide

Heat Pump Wiring Diagrams

Heat Pump Diagram 11: Package Single or Multi-stage Heat Pump with Variable Speed Blower

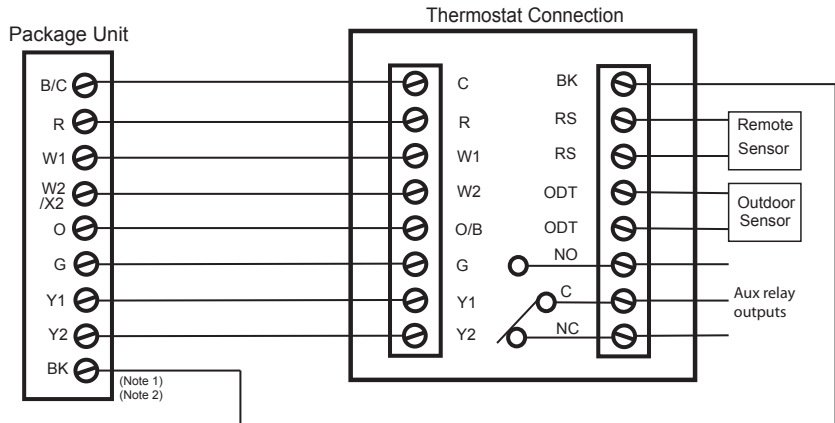

Notes:

1. Cut/remove the factory installed "BK" jumper on the ECM fan control board
2. For non-Trane/American Standard indoor units "BK" is not connected

Remote Temperature Sensor Connections and Operation:

Sensor Options in the Installer Settings/Sensor Settings menu
 Remote Sensor (connect to the RS terminals)
 - None
 - Replaces internal sensor
 - Average with internal sensor
 Outdoor Temp Sensor (connect to the ODT terminals)
 - None
 - Outdoor
 Caution: Do not run sensor wires in the same bundle with HVAC wires. Keep away from high voltage wiring to avoid interference.

Heat Pump Diagram 12: Package Heat Pump with non-Variable Speed Blower

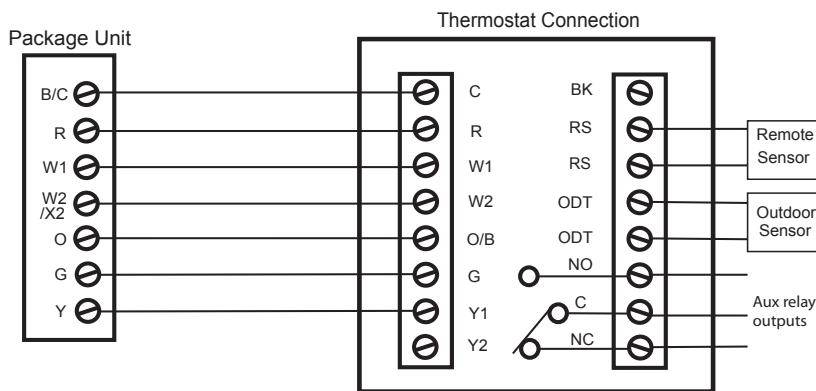

Remote Temperature Sensor Connections and Operation:

Sensor Options in the Installer Settings/Sensor Settings menu
 Remote Sensor (connect to the RS terminals)
 - None
 - Replaces internal sensor
 - Average with internal sensor
 Outdoor Temp Sensor (connect to the ODT terminals)
 - None
 - Outdoor
 Caution: Do not run sensor wires in the same bundle with HVAC wires. Keep away from high voltage wiring to avoid interference.

Installer's Guide

Dual Fuel Wiring Diagrams

Dual Fuel Diagram 1: 1 or 2 Stage Heat Pump w/Variable Speed Gas Furnace

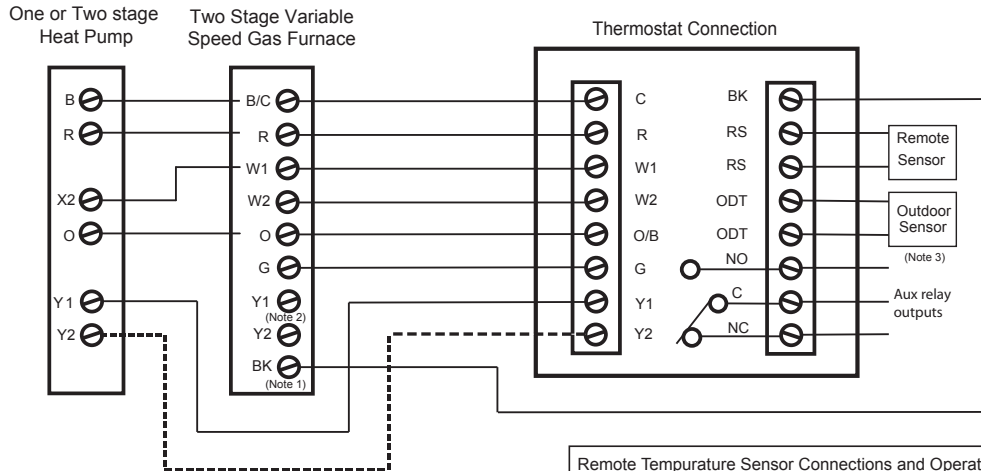

- Notes:
1. Cut/remove the factory installed "BK" jumper at the indoor unit
 2. For non-Trane/American Standard Indoor units "BK" is not connected and "Y1"/"Y2" must be connected at indoor unit.
 3. Outdoor Sensor required for dual fuel restricted mode.

Remote Temperature Sensor Connections and Operation:

- Sensor Options in the Installer Settings/Sensor Settings menu
 Remote Sensor (connect to the RS terminals)
- None
 - Replaces internal sensor
 - Average with internal sensor
- Outdoor Temp Sensor (connect to the ODT terminals)
- None
 - Outdoor
- Caution: Do not run sensor wires in the same bundle with HVAC wires. Keep away from high voltage wiring to avoid interference.

Dual Fuel Diagram 2: 1 Stage Heat Pump w/non-Variable Speed Gas Furnace

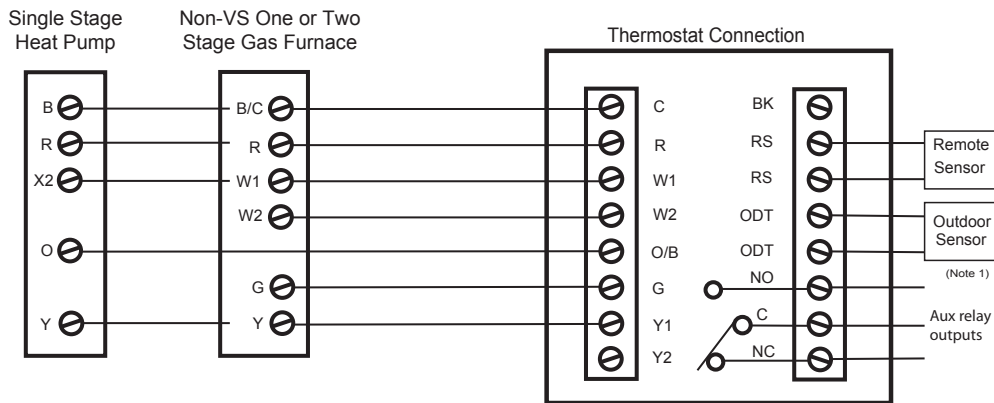

- Note:
1. Outdoor Sensor required for dual fuel restricted mode.

Remote Temperature Sensor Connections and Operation:

- Sensor Options in the Installer Settings/Sensor Settings menu
 Remote Sensor (connect to the RS terminals)
- None
 - Replaces internal sensor
 - Average with internal sensor
- Outdoor Temp Sensor (connect to the ODT terminals)
- None
 - Outdoor
- Caution: Do not run sensor wires in the same bundle with HVAC wires. Keep away from high voltage wiring to avoid interference.

Installer's Guide

Dual Fuel Wiring Diagrams

Dual Fuel Diagram 3: 1 or 2 Stage Heat Pump w/Variable Speed Oil Furnace

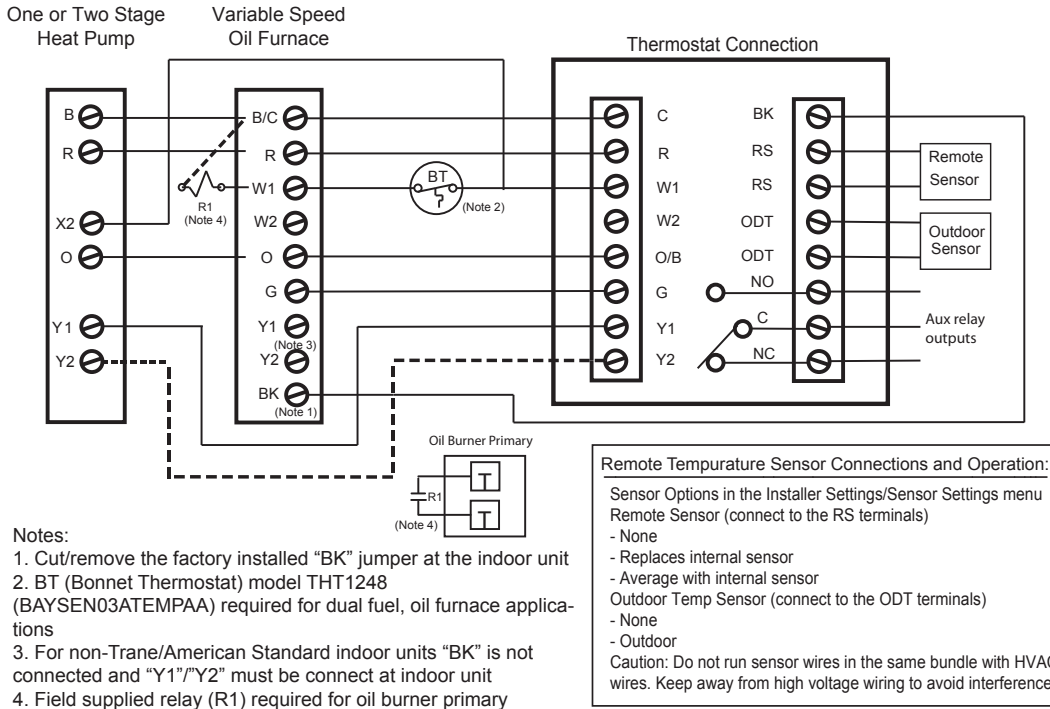

Dual Fuel Diagram 4 : 1 Stage Heat Pump w/non-Variable Speed Oil Furnace

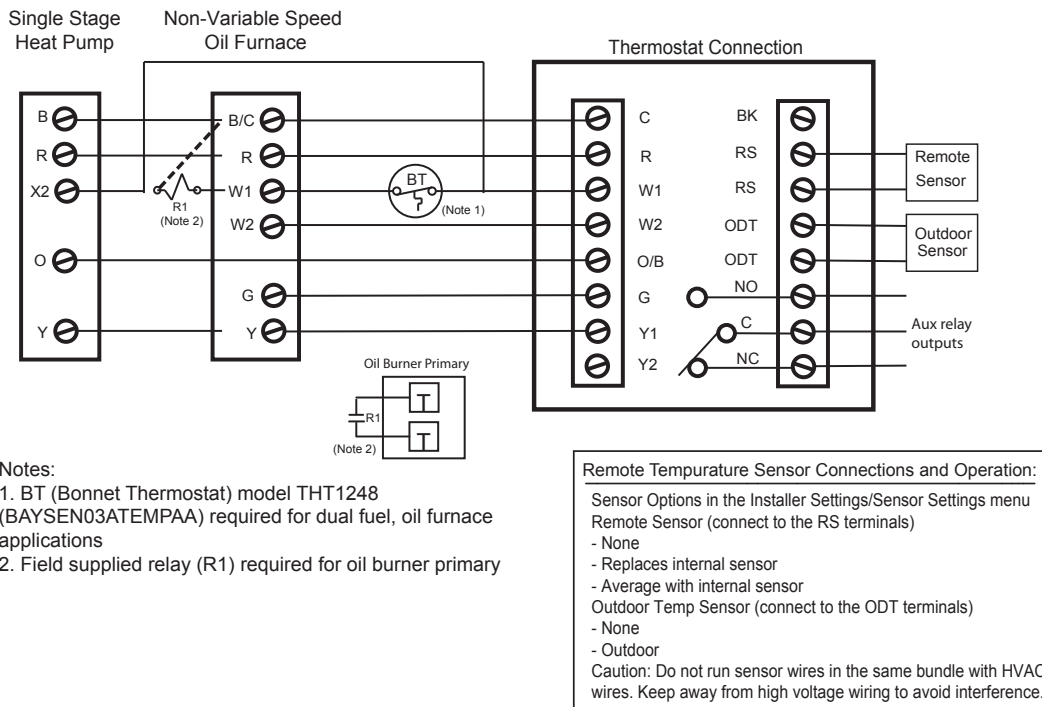

Installer's Guide

Dual Fuel Wiring Diagrams

Dual Fuel Diagram 5: Package Single or Multi-Stage Dual Fuel with Variable Speed Blower

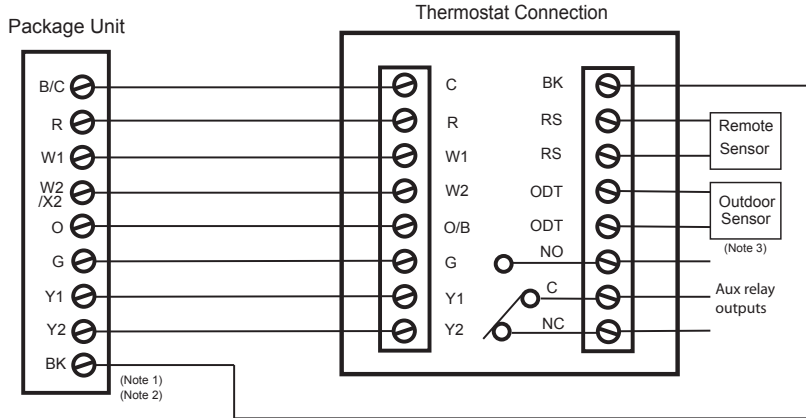

Notes:

1. Cut/remove the factory installed "BK" jumper on the ECM fan control board
2. For non-Trane/American Standard Indoor units "BK" is not connected
3. Outdoor Sensor required for dual fuel restricted mode.

Remote Temperature Sensor Connections and Operation:

Sensor Options in the Installer Settings/Sensor Settings menu

Remote Sensor (connect to the RS terminals)

- None
- Replaces internal sensor
- Average with internal sensor

Outdoor Temp Sensor (connect to the ODT terminals)

- None
- Outdoor

Caution: Do not run sensor wires in the same bundle with HVAC wires. Keep away from high voltage wiring to avoid interference.

Dual Fuel Diagram 6: Package Single Stage Dual Fuel with Non-Variable Speed Blower

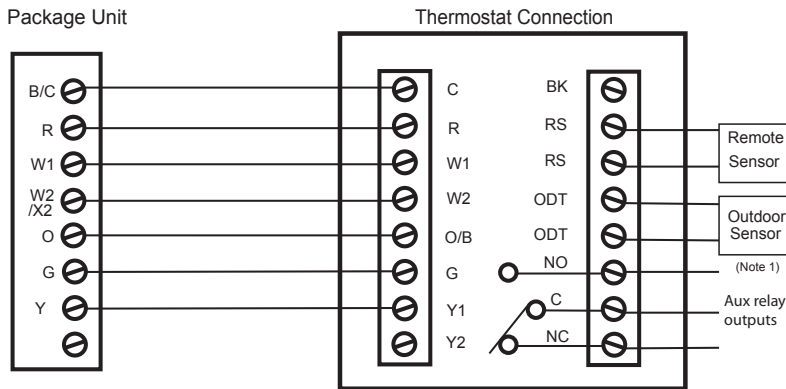

Notes:

1. Outdoor Sensor required for dual fuel restricted mode.

Remote Temperature Sensor Connections and Operation:

Sensor Options in the Installer Settings/Sensor Settings menu

Remote Sensor (connect to the RS terminals)

- None
- Replaces internal sensor
- Average with internal sensor

Outdoor Temp Sensor (connect to the ODT terminals)

- None
- Outdoor

Caution: Do not run sensor wires in the same bundle with HVAC wires. Keep away from high voltage wiring to avoid interference.

Optional Remote Temperature Sensors Installation

Wire specification for remote sensors: 2 conductors, 18 gauge wire. Make sure that the sensor wires are installed in a separate cable from the wiring to the HVAC system. Best results for distances of 100 feet or less. Accuracy may be affected for distances up to a maximum of 200 feet. Shielded cable is recommended for distances over 100 feet and less than 200 feet.



CAUTION: Keep this wiring at least one foot away from large inductive loads such as electronic air cleaners, motors, line starters, lightning ballasts, and large distribution panels. Failure to follow these wiring practices may introduce electrical interference (noise) which can cause erratic system operation. Shielded cable is required if the above wiring guidelines cannot be met. Be sure to ground only one end of the shield to the Comfort Control common terminal. Tape back the other end of the shield.

Remote Sensors Part Numbers

Remote Indoor Sensor: Use ZZSENSAL0400AA for indoor applications.

Remote Outdoor Sensor: Use BAYSEN01ATEMPA for outdoor applications.

- > **IMPORTANT:** Make sure that the sensor wires are installed in a separate cable from the Comfort Control cable.
- > **IMPORTANT:** Follow directions below for averaging. These instructions replace the averaging information found in the Installer's Guide for the ZZSENSAL0400AA.

Remote Temperature Sensor Connections and Operation:

A) Indoor sensor connected to RS.

The Remote Sensor (RS) function can be configured in the Service/Installer Settings/Sensor Settings menu. Options are:

- None
- Replaces onboard temp sensor of the Comfort Control
- Averages with onboard temp sensor

Replace - RS Sensor replaces the internal temperature sensor of the Comfort Control. This allows the Comfort Control to be installed in a location different than the area where the temperature will be measured. Use ZZSENSAL0400AA.

Average - RS Sensor averages its temperatures with the internal sensor. Use ZZSENSAL0400AA.

B) Outdoor sensor connected to ODT. Reports outdoor temperature to the Comfort Control.

The Outdoor Sensor (ODT) function can be configured in the Service/Installer Settings/Sensor Settings menu.

Options are:

- None
- Outside

Outside - ODT (outdoor temperature sensor). If ODT sensor is selected and connected, the outdoor temp is displayed on the main screen. ODT model is BAYSEN01ATEMPA.

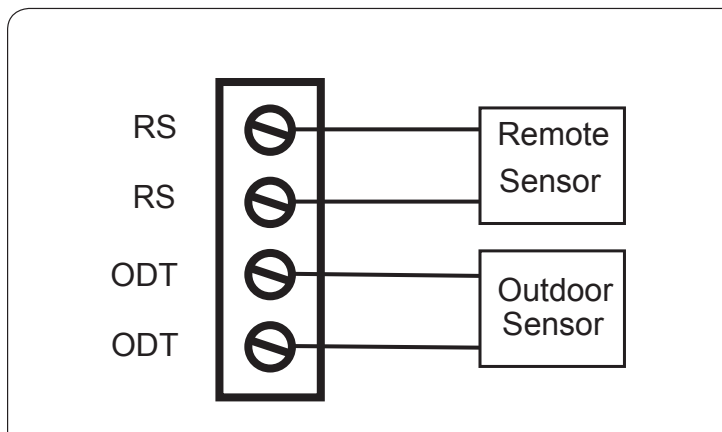

Installer's Guide

Installer's Setup

Installer Settings allow the user to configure the equipment settings and customize how the control operates. To access Installer Settings press the Menu button, then press Next until Service is displayed. Now press Select and hold for 5 seconds until "Installer Settings" is displayed. Press Select again to enter Installer Settings menu. The default setting will be shown in brackets. After each selection press Done to save changes.

Equipment Type		
Setting	Range	Description
Outdoor Unit Type	None, [AC], HP	Select the type of outdoor unit installed
Outdoor Unit Stages	[1], 2	Select the number of outdoor unit stages
Compressor Type	1 Comp - 2 Stage, [2 Comp - 2 Stage]	Select the compressor type for multi-stage outdoor units
Indoor Unit Type	[Gas/Oil], Electric, Hydronic	Select the type of indoor unit installed
Hydronic Type	[Hydro Air], Wet Heat	Select the type of hydronic heat operation. Hydro Air selection interlocks the blower during an active call for indoor heat. Wet Heat selection disables indoor fan operation on an active call for indoor heat.
Indoor Heat Stages	[1], 2	Select the number of indoor heat stages
Indoor Blower Type	[Non - Variable], Variable	Select the indoor blower type (Constant Torque motors are considered non-variable speed)
Energize Reversing Valve	[With Cool], With Heat	Select whether Reversing Valve is energized in cooling or heating mode
Once all selections have been made, press the Done button to exit and return to Menu. Press Next to navigate to the next setting.		
Equipment Settings		
Setting	Range	Description
Compressor Stage 1 MRT	[3] - 9 Minutes	Select the minimum runtime (MRT) of stage 1 compressor operation
Compressor Stage 2 MRT	[3] - 9 Minutes	Select the minimum runtime (MRT) of stage 2 compressor operation
Compressor MOT	[5] - 9 minutes	Select the minimum offtime (MOT) for compressor operation
Indoor Heat Stage 1 MRT	[3] - 9 Minutes	Select the minimum runtime (MRT) of stage 1 indoor heat
Indoor Heat Stage 2 MRT	[3] - 9 Minutes	Select the minimum runtime (MRT) of stage 2 indoor heat
Indoor Heat MOT	[5] - 9 minutes	Select the minimum offtime (MOT) for indoor heat operation
Once all selections have been made, press the Done button to exit and return to Menu. Press Next to navigate to the next setting.		
Sensor Settings		
Setting	Range	Description
Sensor Calibration	*-7 - +7 Degrees [0]	Calibrate the indoor temperature sensor (do not attempt to calibrate the indoor temperature within the 1st hour upon power-up)
Remote Sensor	[None], Replace Indoor, Average	Select whether a remote indoor temperature sensor has been connected, and if a remote sensor has been connected, indicate whether to use the remote sensor to replace the onboard temperature sensor or average the two.
Remote Sensor Calibration	*-7 - +7 Degrees [0]	Calibrate the remote temperature sensor
Outdoor Sensor	[None], Outdoor	Select whether an outdoor temperature sensor has been connected
Outdoor Sensor Calibration	*-7 - +7 Degrees [0]	Calibrate the outdoor temperature sensor
RH Calibration	*-7% - +7% [0]	Calibrate the RH sensor
Once all selections have been made, press the Done button to exit and return to Menu. Press Next to navigate to the next setting.		
Accessories		
Setting	Range	Description
Aux Relay	[None], Humidifier, Ventilation, Dehumidifier	Select what accessory the Aux Relay is controlling
Humidifier Control Options	With Active Heat, [w/o Active Heat]	Select whether the humidifier is allowed to operate with an active call for heat only or stand-alone operation (humidifier operates independent from heating operation)
Ventilation On Timer	[Off], 1 - 60 Minutes	Select the minimum runtime per hour of the ventilation equipment
Once all selections have been made, press the Done button to exit and return to Menu. Press Next to navigate to the next setting.		

Installer's Guide

Installer's Setup Continued

Comfort Setting		
Setting	Range	Description
Enhanced Dehumidification	[Yes], No	When dehumidification is enabled, the control will reduce system airflow by 30% (variable speed indoor units only) anytime the indoor humidity is higher than the cooling target humidity setpoint and the indoor temperature is within 2°F of cooling setpoint. All fan off delays will also be cancelled.
Dehumidification Overcooling Limit	[Off], 1, 2, 3 Degree	Select the maximum amount of overcooling allowed when the indoor humidity exceeds the cooling target humidity setpoint. To accomplish the overcooling the control will artificially create additional load by increasing the sensed indoor temperature by 1/10th of a degree for every 1% of humidity error, up to the overcooling limit selected. The displayed indoor temperature will remain the same, but the adjusted indoor temperature will control cooling operation.
HP Warm Air Discharge	Yes, [No]	When enabled the indoor blower speed will be limited to 80% on a call for heat pump heating. This only applied to heat pump heating with no call for aux heat. An indoor unit with variable speed blower is required.
Comp Heat Delta Stage 1 On	.5 - 8 Degree	Select the delta on for 1st stage compressor heat
Comp Heat Delta Stage 2 On	1 - 8 Degree	Select the delta on for 2nd stage compressor heat
Indoor Heat Delta Stage 1 On	.5 - 8 Degree	Select the delta on for 1st stage indoor heat
Indoor Heat Delta Stage 2 On	1 - 8 Degree	Select the delta on for 2nd stage indoor heat
Comp Heat Delta Stage 1 Off	0 - 8 Degree	Select the delta off for 1st stage compressor heat
Comp Heat Delta Stage 2 Off	0 - 8 Degree	Select the delta off for 2nd stage compressor heat
Indoor Heat Delta Stage 1 Off	0 - 8 Degree	Select the delta off for 1st stage indoor heat
Indoor Heat Delta Stage 2 Off	0 - 8 Degree	Select the delta off for 2nd stage indoor heat
Cooling Delta Stage 1 On	.5 - 8 Degree	Select the delta on for 1st stage cooling
Cooling Delta Stage 2 On	1 - 8 Degree	Select the delta on for 2nd stage cooling
Cooling Delta Stage 1 Off	(-) 2 - (+)6	Select the delta off for 1st stage cooling
Cooling Delta Stage 2 Off	0 - 7	Select the delta off for 2nd stage cooling
Heat Stage Up Timer	[Off], 5 - 60 Minutes	Select the amount of time that 1st stage can operate before transitioning to 2nd stage, regardless of delta on setting. This setting only applies to the primary heat source not aux heat or transition from primary source to aux heat (Y1 to Y2 for heat pump/duel fuel systems and W1 to W2 for heat/cool systems)
Cool Stage Up Timer	[Off], 5 - 60 Minutes	Select the amount of time in 1st stage cooling that will force the system to 2nd stage, regardless of the cooling delta stage on setting
Recovery Enable	Yes, [No]	When enabled, will start the cooling or heating system so that the desired comfort temperature is reached by the next scheduled set point time. The advance start time calculation is a learned process that is recalculated and adjusted each day until the room temperature is at the target temperature at the schedule time. When the thermostat is in Recovery mode the display will show "Recov". While in Recovery the Aux-Heat stage will not engage. The maximum Recovery time is one hour.

Once all selections have been made, press the Done button to exit and return to Menu. Press Next to navigate to the next setting.

Installer's Guide

Installer's Setup Continued

Airflow Settings		
Setting	Range	Description
Blower On Delay Cooling	Disabled, [Enhanced], 30 Second Delay, 1 Minute At 50%, 4 Minutes At 80%, 7.5 Minutes at 80%, 1 Minute At 50% 4 Minutes At 80%	(Variable Speed indoor blower only) Select the cooling blower on delay. Enhanced setting is 1 minute at 50% blower speed then 7.5 minutes at 80% blower speed and finally 100% blower speed.
Blower On Delay Cooling	[0] - 30 seconds	(Non-Variable Speed blower only) Select the cooling blower on delay
Blower Off Delay Cooling	Disabled, 30 Seconds At 35%, 3 Minutes At 50%, [1.5 Minutes At 50%], 30 Seconds At 50%, 45 Seconds At 100%, 1.5 Minutes At 100%	(Variable Speed indoor blower only) Select the cooling blower off delay
Blower Off Delay Cooling	[0] - 90 Seconds	(Non-Variable Speed blower only) Select the cooling blower off delay
Blower On Delay Heating	Disabled, [Enhanced], 30 Second Delay, 1 Minute At 50%, 4 Minutes At 80%, 7.5 Minutes at 80%, 1 Minute At 50% 4 Minutes At 80%	(Variable Speed indoor blower only) Select the compressor heating blower on delay. Enhanced setting is 1 minute at 50% blower speed then 7.5 minutes at 80% blower speed and finally 100% blower speed.
Blower On Delay Heating	[0] - 30 Seconds	(Non-Variable Speed blower only) Select the compressor heating blower on delay
Blower On Delay Heating	[0] - 60 Seconds	Select the hydronic heating blower on delay
Blower Off Delay Heating	Disabled, 30 Seconds At 35%, 3 Minutes At 50%, [1.5 Minutes At 50%], 30 Seconds At 50%, 45 Seconds At 100%, 1.5 Minutes At 100%	(Variable Speed indoor blower only) Select the compressor heating blower off delay
Blower Off Delay Heating	[0] - 90 Seconds	(Non-Variable Speed blower only) Select the compressor heating blower off delay
Blower Off Delay Heating	[0] - 90 Seconds	Select the hydronic heating blower off delay
1st Stage Airflow Cool	35% - 60%, [50%]	(2 compressor 2 stage only) Select 1st stage cooling airflow
1st Stage Airflow Cool	55% - 80%, [65%]	(1 compressor 2 stage only) Select 1st stage cooling airflow
1st Stage Airflow Heat	35% - 60%, [50%]	(2 compressor 2 stage only) Select 1st stage heating airflow
1st Stage Airflow Heat	55% - 80%, [65%]	(1 compressor 2 stage only) Select 1st stage heating airflow
Once all selections have been made, press the Done button to exit and return to Menu. Press Next to navigate to the next setting.		
Lockouts (Outdoor Temperature Sensor must be enabled)		
Setting	Range	Description
Aux Heating Lockout	Yes, [No]	Enable auxiliary heat lockout above. If disabled, the auxiliary heat will only operate when the delta stage "On" threshold has been met in Heat Pump heating mode.
Aux Lockout Outdoor Temp	30 - 70 Degrees [50]	Select an outdoor temperature to inhibit auxiliary heating above the selected outdoor temperature
Comp Heating Lockout	Yes, [No]	Enable compressor heat lockout below. If disabled, the compressor heat will operate anytime the delta stage "On" threshold has been met in Heat Pump heating mode.
Comp Lockout Outdoor Temp	5 - 60 Degrees [20]	Select an outdoor temperature to inhibit compressor heating below the selected outdoor temperature
Once all selections have been made, press the Done button to exit and return to Menu. Press Next to navigate to the next setting.		

Installer's Guide

Test Mode

Test Mode allows the servicer to test system operation without waiting for the system to stage up/down. Also all minimum on and off times are disabled during test mode. Once a specific test has started, the test will last for 30 minutes unless the servicer ends the test by pressing the Done button. A countdown timer will be displayed during test mode indicating how much time is left in the test. To access Test Mode press the Menu button, then press Next until Service is displayed. Now press Select and hold for 5 seconds until "Installer Settings" is displayed. Press Next until Test Mode is displayed. Now press Select again to enter Test Mode.

Test Mode		
Test Mode	Settings	Description
Blower (Non-VS)	Blower On	Energize "G" circuit
Blower (VS)	50%, 100%	Energize "G" and "BK" circuit
Cooling	Single Stage, 1st Stage, 2nd Stage	Energize selected "Y", "Y1" or "Y2", "O" and "G" circuit (BK also for VS indoor unit)
Comp Heating	Single Stage, 1st Stage, 2nd Stage	Energize selected "Y", "Y1" or "Y2" and "G" circuit ("BK" also for VS indoor unit)
Indoor Heating	Single Stage, 1st Stage, 2nd Stage	Energize selected "W", "W1" or "W2" ("G" circuit also for electric heat)
Aux Relay	Relay On	Close normally open dry contacts
Once testing is complete, press the Done button to exit and return to Menu.		

Restore Defaults

Restore Defaults is used to restore the control to factory default settings. To access "Restore Defaults" press the Menu button, then press Next until "Service" is displayed. Now press Select and hold for 5 seconds until "Installer Settings" is displayed. Press Next until "Restore Default" is displayed. Now press Select again to enter "Restore Default". The default setting will be shown in brackets. After each selection press Done to save changes.

Restore Defaults		
Setting	Range	Description
Restore Default	Yes, [No]	Select "Yes" to restore all the User and Installer settings to the factory defaults. If "Yes" is selected "Restoring" will be displayed. "Done" will be displayed once all settings have been restored.
Note: To reset all User , Installer and Z-Wave settings, press and hold the "Yes" button for 5 seconds. Release when "Factory Defaults" is displayed. "Done" will be displayed once all settings have been restored and the control will automatically return to the home screen..		

Installer's Guide

Troubleshooting

Troubleshooting		
Symptom	Possible Cause	Action
Display will not come on	Loss of 24VAC between R & C at the Control	<ol style="list-style-type: none"> 1) Check wiring between R & C 2) Check transformer for 24VAC output 3) Check for broken or shorted thermostat wire
Indoor Temperature display is incorrect	<ol style="list-style-type: none"> 1) Indoor temperature display needs calibrating (always allow 1 hour before calibrating after any power cycle) 2) Heat from the touchscreen is being trapped within the body of the control 	<ol style="list-style-type: none"> 1) Calibrate indoor temperature sensor 2) Relocate the control away from any competing air sources or redirect the air sources away from the control
Indoor humidity display is incorrect	Indoor humidity sensor needs calibrating	Calibrate humidity sensor
Room temperature overshoots the desired setpoint in cooling mode	<ol style="list-style-type: none"> 1) The delta "Off" in cooling mode is set to a negative number 2) Cooling overshoot is enabled and the indoor RH is higher than the target cooling RH 3) Minimum compressor on time has not been met 	<ol style="list-style-type: none"> 1) Intended operation; if objectionable, change the delta "Off" to 0 degrees 2) Intended operation; if objectionable, disable cooling overshoot or raise cooling target RH 3) Intended operation; if objectionable, lower minimum on time (lowest setting available is 3 minutes)
Room temperature overshoots the desired setpoint in heating mode	Minimum compressor/indoor heat on time has not been met	Intended operation; if objectionable, lower the minimum on time (lowest setting available is 3 minutes)
Cooling will not come on	<ol style="list-style-type: none"> 1) System mode is not set to Cool/Auto or setpoint is set too high 2) Delta "On" for cooling is set too high 3) Minimum off time delay is being enforced 4) Cooling system may need service 	<ol style="list-style-type: none"> 1) Select the correct system mode and/or lower the setpoint 2) Change the delta "On" setting for cooling mode 3) Intended operation; if objectionable, lower the minimum off time delay (lowest setting is 5 minutes) 4) Check/repair system
Heating will not come on	<ol style="list-style-type: none"> 1) System mode is not set to Heat/Auto or setpoint is set too low 2) Delta "On" for heating is set too high 3) Minimum off time delay is being enforced 4) Heating system may need service 	<ol style="list-style-type: none"> 1) Select the correct system mode and/or raise the setpoint 2) Change the delta "On" setting for heating mode 3) Intended operation; if objectionable, lower the minimum off time delay (lowest setting is 5 minutes) 4) Check/repair system
Heating or Cooling is being displayed, but no air coming from registers/vents	<ol style="list-style-type: none"> 1) Fan delay time has not expired 2) System is not operating properly 	<ol style="list-style-type: none"> 1) Wait one minute for blower delay to end, then recheck register/grills 2) Check/repair system
Fan runs all the time	<ol style="list-style-type: none"> 1) Fan mode is set to "On" or "Circ" 2) System is not operating properly 	<ol style="list-style-type: none"> 1) Intended operation; if objectionable, change fan mode to "Auto" 2) Check/repair system
Fan is set to "On" but not running	<ol style="list-style-type: none"> 1) Smart continuous fan is enabled and the indoor humidity is higher than the cooling target RH (SCF will be displayed on fan mode button) 2) System is not operating properly 	<ol style="list-style-type: none"> 1) Intended operation; if objectionable, disable SCF or raise cooling target humidity 2) Check/repair system
On Nexia Climate tab, 624 icon remains gray and cannot be selected.	<ol style="list-style-type: none"> 1) Bridge and 624 are not able to communicate via Z-wave. 	<ol style="list-style-type: none"> 1) Verify Nexia bridge is not located inside of an enclosure and is not sitting directly on other electrical equipment. 2) If bridge and 624 are more than 30' apart, enroll a Z-wave repeater (plug-in dimmer or appliance module) into the bridge, and plug repeater into outlet midway between bridge and 624. 3) Temporarily turn off other nearby wireless transmitters such as baby monitors <p>After checking 1-3, click on Climate page and allow 1-2 minutes for icon to turn blue</p>

Installer's Guide

Troubleshooting continued

Troubleshooting		
Symptom	Possible Cause	Action
624 remote operation with Nexia is intermittent.	1) Bridge and 624 have marginal Z-wave communications.	<ol style="list-style-type: none">1) In Nexia: Go to Edit Home, Advanced2) Find the 624 and click on "Test Connection" button.3) If test results are less than 80%, enroll a Z-wave repeater (plug-in dimmer or appliance module) into the bridge, and plug repeater into outlet midway between bridge and 624.4) Repeat steps 1-2 and verify communications is greater than 80%.
624 remote operation with Nexia previously worked, but now does not.	1) Bridge and 624 have lost the ability to communicate via Z-wave	<ol style="list-style-type: none">1) Verify Nexia bridge has not been moved. If yes, then move bridge back to original location and then re-test remote features.2) Verify bridge is connected to AC power and to an active Ethernet (internet) connection.3) Verify a Z-wave repeater has not been unplugged or removed. If yes, then restore the repeater to its original location.4) Verify that new wireless equipment has not been added to the home. If yes, temporarily unpower the new equipment and then re-test 624.

Warranty

Base Limited Warranty

Subject to the terms and conditions of this limited warranty, Trane U.S., Inc. ("Company") extends a limited warranty against manufacturing defects for the product(s) identified in **Tables 1, 1A, 1B** attached hereto ("Products") that are installed in a residential/multi-family application (personal, family or household purposes) under normal use and maintenance in the United States and Canada.

This limited warranty applies to Products manufactured on or after August 1, 2011.

In order to maximize the available benefits under this limited warranty, the Purchaser (as defined below) should read it in its entirety. All repairs of Product parts covered under this limited warranty must be made with authorized service parts and by a licensed HVAC service provider. Additionally, commercial applications are treated differently under this limited warranty as stated in **Tables 1, 1A, 1B** attached hereto. For purposes of this limited warranty, "commercial applications" shall mean any application other than for personal, family, or household use.

TERM: The limited warranty period for Products is as stated in **Tables 1, 1A, 1B** attached hereto. If the Purchaser properly registers the Products, the limited warranty period shall be extended as stated in **Tables 1, 1A, 1B** attached hereto. Regardless of registration, the Commencement Date for a limited warranty period shall be the date that the original installation is complete and all Product start-up procedures have been properly completed and verified by an installer's invoice. If the installation and start-up date cannot be verified by the installer's invoice, the Commencement Date shall be sixty (60) days after the factory manufacture date which is verified by the Product serial number. Where a Product is installed in a newly constructed home, the Commencement Date is the date the Purchaser purchased the residence from the builder. Proof of Product purchase, installation, and/or closing date of the residence may be required to confirm the Commencement Date.

The installation of Product replacement parts under this limited warranty shall not extend the original warranty period. The warranty period for any Product part replaced under this limited warranty is the applicable warranty period remaining under the original Product warranty.

WHO IS COVERED: This limited warranty is provided only to the original owner and his or her spouse ("Purchaser") of the residence where the Products are originally installed. This warranty is not transferable except according to terms stated on the applicable website identified below under Registration Requirements. Company has the right to request any and all proof of Product purchase or installation and/or closing date of the residence.

WHAT COMPANY WILL DO: Company may request proof of Product purchase and/or installation in order to provide Product parts under this limited warranty. As Company's only responsibility and Purchaser's only remedy under this limited warranty, Company will furnish a replacement part to the licensed HVAC service provider, without charge for the part only, to replace any Product part that fails due to a manufacturing defect under normal use and maintenance. The Purchaser must pay for any and all shipping and handling charges and other costs of warranty service for the replacement part. If a Product part is not available, Company will, at its option, provide a free suitable substitute part or provide a credit in the amount of the then factory selling price for a new suitable substitute part to be used by the Purchaser towards the retail purchase price of a new Company product. Any new Product purchase shall be at Purchaser's sole cost and expense including, but not limited to, all shipping, removal, and installation costs and expenses.

REGISTRATION REQUIREMENTS: All Products must be properly registered online by the Purchaser within sixty (60) days after the Commencement Date to receive the registered limited warranty terms. To register online, go to:

<http://www.trane.com/Residential/For-Owners/Warranties> or

<http://www.americanstandardair.com/servicesupport/pages/warranty.aspx>

and click "Begin Online Registration." If a Purchaser does not register within this stated time period, the base limited warranty terms shall apply.

ELIGIBILITY REQUIREMENTS: The following items are required in order for the Products to be covered under this limited warranty:

- The Products must be in the same location where they were originally installed.
- The Products must be properly installed, operated, and maintained by a licensed HVAC service provider in accordance with the Product specifications or installation, operation, and maintenance instructions provided by Company with each Product. Failure to conform to such specifications and/or instructions shall void this limited warranty. Company may request written documentation showing the proper preventative maintenance.
- All Product parts replaced by Company under this limited warranty must be given to the servicing provider for return to Company.
- Air handlers, air conditioners, heat pumps, cased or uncased coils and stand-alone furnaces must be part of an Air Conditioning, Heating, and Refrigeration Institute rated and matched system or a specification in a Company provided bulletin or otherwise approved in writing by a Company authorized representative.

EXCLUSIONS: The following are not covered by this limited warranty:

- *Labor costs including, but not limited to, costs for diagnostic calls or the removal and reinstallation of Products and/or Product parts.*
- *Shipping and freight expenses required to ship Product replacement parts.*
- *Failures, defects, or damage (including, but not limited to, any loss of data or property) caused by (1) any third party product, service, or system connected or used in conjunction with the Products; (2) any use that is not designed or intended for the Products; (3) modification, alteration, abuse, misuse, negligence, or accident; (4) improper storage, installation, maintenance, or operation including, but not limited to, operation of electrical equipment at voltages other than the range specified on the Product nameplate; (5) any use in violation of written instructions or specifications provided by Company; (6) any acts of God including, but not limited to, fire, water, storms, lightning, or earthquakes; or any theft or riots; or (7) a corrosive atmosphere or contact with corrosive materials such as, but not limited to, chlorine, fluorine, salt (provided that indoor and outdoor coils will only be covered if a Sea Coast Kit is installed), sulfur, recycled waste water, urine, fertilizers, rust, or other damaging substances or chemicals.*
- *Products purchased direct including, but not limited to, Internet or auction purchases and purchases made on an uninstalled basis.*
- *Cabinets or cabinet pieces that do not affect product performance, air filters, refrigerant, refrigerant line sets, belts, wiring, fuses, surge protection devices, non-factory installed driers, and Product accessories (unless otherwise specified).*
- *Increased utility usage costs.*

REFRIGERANT POLICY: (1) **Manufacturer-Installed Refrigerant:** Beginning on January 1, 2010, R-22 refrigerant will no longer be used as a manufacturer-installed refrigerant as required by federal regulation. All Products with manufacturer-installed refrigerant will include R-410A refrigerant. Any and all expenses or costs associated with replacing Product parts that are not R-410A compatible will not be covered by the terms and conditions of this limited warranty. (2) **Non-Manufacturer installed Refrigerant:** For Products manufactured and sold by the Company without refrigerant, only manufacturer approved and genuine alternate refrigerants shall be used. The use of contaminated, counterfeit, non-genuine, or non-manufacturer approved alternate refrigerant will void this limited warranty. (3) **All Products:** Products include a liquid line filter drier which must be replaced when a compressor replacement is necessary. A suction line filter drier must be added for compressors defined as burnouts and failure to do so will void this warranty. Non-approved refrigerant and/or non-approved refrigerant system additives including, but not limited to dyes will void this limited warranty.

GW-658-2913

Warranty

ADDITIONAL TERMS:

THIS LIMITED WARRANTY AND LIABILITY SET FORTH HEREIN ARE IN LIEU OF ALL OTHER WARRANTIES AND LIABILITIES, WHETHER IN CONTRACT OR IN NEGLIGENCE, EXPRESS OR IMPLIED, IN LAW OR IN FACT. THE IMPLIED WARRANTIES OF MERCHANTABILITY AND FITNESS FOR A PARTICULAR PURPOSE ARE LIMITED TO THE DURATION OF THE APPLICABLE PRODUCT WARRANTY. COMPANY DOES NOT AUTHORIZE ANY PERSON TO CREATE FOR IT ANY OBLIGATION OR LIABILITY IN CONNECTION WITH THE PRODUCTS.

NOTWITHSTANDING ANYTHING IN THIS LIMITED WARRANTY TO THE CONTRARY, COMPANY SHALL NOT BE LIABLE FOR ANY INCIDENTAL, CONSEQUENTIAL, INDIRECT, SPECIAL AND/OR PUNITIVE DAMAGES, WHETHER BASED ON CONTRACT, WARRANTY, TORT (INCLUDING, BUT NOT LIMITED TO, STRICT LIABILITY OR NEGLIGENCE), PATENT INFRINGEMENT, OR OTHERWISE, EVEN IF ADVISED OF THE POSSIBILITY OF SUCH DAMAGES. COMPANY'S MAXIMUM LIABILITY HEREUNDER IS LIMITED TO THE ORIGINAL PURCHASE PRICE OF THE PRODUCTS.

No action arising out of any claimed breach of this limited warranty may be brought by a Purchaser more than one (1) year after the cause of action has arisen.

This limited warranty gives you specific legal rights, and you may also have other rights as otherwise permitted by law. If this Product is considered a consumer product, please be advised that some local laws do not allow limitations on incidental or consequential damages, how long a warranty lasts based on registration, or how long an implied warranty lasts, so that the above limitations may not fully apply. Refer to your local laws for your specific rights under this limited warranty.

Consumer Relations

20 Corporate Woods Dr.

Bridgeton, MO 63044

Or visit our website at www.trane.com or www.americanstandardair.com

Table 1A: Warranty Time Periods for Controls, Zoning Products, Humidifiers, Energy Recovery Ventilators, Air Cleaners and Oil Furnaces (Variable and Non-Variable Speed)

COVERAGE TERMS FOR RESIDENTIAL APPLICATIONS: Pursuant to the Trane U.S., Inc. ("Company") limited warranty terms and conditions, the following Products are covered for the base time periods as stated below ("Base Limited Warranty period"). If registered, the Base Limited Warranty Periods for certain products will be extended as stated below ("Registered Limited Warranty Period").

CONTROLS: *CONT200,*CONT401,*CONT402, *CONT600, *CONT602, *CONT624

Base Limited Warranty Period: one (1) year

Registered Limited Warranty Period: five (5) years

CONTROLS: *ZEMT500,*CONT800,*CONT802,*CONT803, *CONT824, *CONT900, *ZONE940, *ZONE950

Base Limited Warranty Period: five (5) years

Registered Limited Warranty Period: ten (10) years

ZONING PRODUCTS: *ZONE950, *ZONE940, *ZONE930, ZZONEPNLAC52Z, ZZONEEXPAC52Z, ZZSENSAL0400, BAYSEN01ATEMPA, BAY24VRP, ZDAMP RD, ZDAMP SM, ZDAMP BM, ZDAMP RR

Base Limited Warranty Period: five (5) years

Registered Limited Warranty Period: ten (10) years

HUMIDIFIERS: *HUMD200, *HUMD300 & *HUMD500

Base Limited Warranty Period: five (5) years

Registered Limited Warranty Period: ten (10) years

ENERGY RECOVERY VENTILATOR (ERV): *ERVR100, *ERVR200 & *ERVR300

Base Limited Warranty Period: five (5) years

Registered Limited Warranty Period: ten (10) years

AIR CLEANERS: TFD & AFD

Base Limited Warranty Period: five (5) years

Registered Limited Warranty Period: ten (10) years

VARIABLE SPEED OIL FURNACE: *HV-V, *LF-V, *LR-V,*DF-V

Base Limited Warranty Period: Parts- five (5) years, Heat Exchanger - twenty (20) years

Registered Limited Warranty Period: Parts - ten (10) years, Heat Exchanger - Lifetime

FCC Notice

FCC ID WIBTZW012

INFORMATION TO USER

This device complies with Part 15 of the FCC Rules. Operation is subject to the following two conditions: (1) This device may not cause harmful interference, and (2) This device must accept any interference received, including interference that may cause undesired operation.

This equipment has been tested and found to comply with the limits for Class B Digital Device, pursuant to Part 15 of the FCC Rules. These limits are designed to provide reasonable protection against harmful interference in a residential installation. This equipment generates and can radiate radio frequency energy and, if not installed and used in accordance with the instructions, may cause harmful interference to radio communications. However, there is no guarantee that interference will not occur in a particular installation. If this equipment does cause harmful interference to radio or television reception, which can be determined by turning the equipment off and on, the user is encouraged to try to correct the interference by one or more of the following measures.

- Reorient or relocate the receiving antenna
- Increase the separation between the equipment and receiver
- Connect the equipment into an outlet on a circuit different from that to which the receiver is connected
- Consult the dealer or an experienced radio/TV technician for help

Any changes or modifications not expressly approved by the party responsible for compliance could void the user's authority to operate the equipment.

IC Notice

IC 9374A-XR624

This device complies with Industry Canada license-exempt RSS standard(s). Operation is subject to the following two conditions: (1) this device may not cause interference, and (2) this device must accept any interference, including interference that may cause undesired operation of the device.

Le présent appareil est conforme aux CNR d'Industrie Canada applicables aux appareils radio exempts de licence. L'exploitation est autorisée aux deux conditions suivantes : (1) l'appareil ne doit pas produire de brouillage, et (2) l'utilisateur de l'appareil doit accepter tout brouillage radioélectrique subi, même si le brouillage est susceptible d'en compromettre le fonctionnement.



©2013 Trane

Trane
6200 Troup Highway
Tyler, TX 75707
www.trane.com

Literature Order Number	18-HD45D1-5
File number	18-HD45D1-5
Supersedes	18-HD45D1-4
Date	10/13

Trane has a policy of continuous product and product data improvement and it reserves the right to change design and specifications without notice.