

Panasonic

Voice Processing System Installation Manual

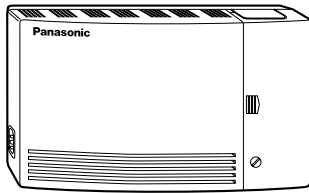

Model No. **KX-TVS50**



Thank you for purchasing a Panasonic Voice Processing System, Model KX-TVS50.
Please read this manual before installing, customizing, or operating the Voice Processing System.

Thank you for purchasing the Panasonic Model
KX-TVS50 Voice Processing System.

We are confident that it will provide your customer or client with many years of dependable service.

This Voice Processing System was especially tailored for the American environment. For example, it can be configured for English, a second language, or a third language:

System prompts—Recorded at the factory in English

User 1 prompts—Record in any language you like

User 2 prompts—Record in any language you like

These prompts guide subscribers and non-subscribers through specific VPS operations.

However, we would like to stress that for outside callers who merely need to be guided to an extension, a mailbox, or other destinations (e.g., a fax machine), they can be greeted by a **Custom Service**. This supports *many languages* as there are 12 keys on a touchtone phone and you can record up to 100 Custom Service menus. One twelfth of these menus can be recorded in one language if you desire. Another twelfth can be recorded in another language, and so on. Thus callers can be guided entirely in their native languages. For a multi-cultural United States, Custom Service is a truly powerful feature. Please see "Custom Service" in Appendix A1 SYSTEM FEATURES for more details.

Note

This product is only for connection behind a suitable PBX and should not be connected directly to the network.

Panasonic World Wide Web Address: <http://www.panasonic.com>
for customers in the United States or Puerto Rico.

Important Information

SAFETY REQUIREMENTS

- Follow all product warnings, cautions, and instructions.
- Handle the unit carefully. Do not drop or otherwise expose the unit to physical shock.
- If the unit malfunctions, disconnect the unit from the telephone line and check the line by reconnecting the telephone. If the telephone operates properly, have the VPS repaired by a qualified Panasonic Factory Service Technician.
- Install the unit so that the power cord is not obstructed in any way. Do not connect this unit to an extension cord.
- Keep the unit free of dust, moisture, condensation, high temperature exposure (more than 40 °C {104 °F}) and vibration. Do not expose the unit to direct sunlight.
- Mount the unit on a stable wall surface. Do not mount the VPS inside of a separate enclosure unless it is properly ventilated.
- Read all the information contained in this manual.
- This unit is designed to operate at one specific voltage and current setting. The proper voltage and current required for this unit are listed on the product label.
- This unit is equipped with a 3-wire grounding plug. The plug will only fit into a grounded power outlet. Do not modify this plug in any way. If it cannot be inserted into the outlet, have the outlet replaced by a licensed electrician.
- Unplug and transport the unit to a service technician if the power supply cord is frayed or damaged, if the cabinet is cracked or broken, or when the unit has been exposed to moisture, has been dropped, or is not otherwise operating properly.
- Unplug the unit from its power source before cleaning.
- Do not block the vent slots and openings located on the front and top of the unit.
- Do not disassemble this product. Dangerous electrical shock could result. The unit must only be disassembled and repaired by qualified Panasonic Factory Service Technicians.
- Do not insert wires, pins, or any other material into the unit's vent slots or access points. This could result in electrical shock and serious unit malfunction.
- Do not install the unit near water or moisture, heating appliances, or electrical noise generating devices such as televisions, monitors, fluorescent lamps, or electric motors.
- Do not overload wall outlets. Overloaded outlets could result in fire and/or electrical shock.
- Do not use solvents, liquid cleaners, water, or abrasive powders to clean this unit. Use only a damp soft cloth for cleaning.
- Do not use the telephone during a lightning storm or to report a gas leak in the vicinity of the leak.

WARNING

TO PREVENT FIRE OR ELECTRICAL SHOCK, DO NOT EXPOSE THIS UNIT TO RAIN OR MOISTURE.

When you ship the product

Carefully pack and send it prepaid, adequately insured and preferably in the original carton. Attach a postage-paid letter, detailing the symptom, to the outside of the carton. **DO NOT** send the product to the Executive or Regional Sales offices. They are **NOT** equipped to make repairs.

Product service

Panasonic Factory Servicenters for this product are listed in the servicenter directory. Consult your authorized Panasonic dealer for detailed instructions.

The serial number of this product may be found on the label affixed to the back of the unit. You should note the serial number of this unit in the space provided and retain this book as a permanent record of your purchase to aid in identification in the event of theft.

MODEL NO.: _____

SERIAL NO.: _____

For your future reference

DATE OF PURCHASE _____

NAME OF DEALER _____

DEALER'S ADDRESS _____

DEALER'S TEL. NO. _____

WARNING

THIS UNIT MAY ONLY BE INSTALLED AND SERVICED BY QUALIFIED SERVICE PERSONNEL.

WHEN A FAILURE OCCURS WHICH RESULTS IN THE INTERNAL PARTS BECOMING ACCESSIBLE, DISCONNECT THE POWER SUPPLY CORD IMMEDIATELY AND RETURN THIS UNIT TO YOUR DEALER.

DISCONNECT THE TELECOM CONNECTION BEFORE DISCONNECTING THE

POWER CONNECTION PRIOR TO RELOCATING THE EQUIPMENT, AND RECONNECT THE POWER FIRST.

THIS UNIT IS EQUIPPED WITH AN EARTHING CONTACT PLUG. FOR SAFETY REASONS, THIS PLUG MUST ONLY BE CONNECTED TO AN EARTHING CONTACT SOCKET WHICH HAS BEEN INSTALLED ACCORDING TO REGULATIONS.

CAUTION

Danger of explosion if battery is incorrectly replaced.

Replace only with the same or equivalent type recommended by the manufacturer.

Dispose of used batteries according to the manufacturer's instructions.

Note

Before you start setting or changing system parameters, we recommend that you turn off the Call Progression Mode with the OFLN command. While off, the power LED of the VPS will flash and the VPS will not answer any incoming call. After you finish programming, use the ONLN command to turn on the Call Progression Mode (normal operation). Please see 7.2.1 Off-line Set (OFLN) and 7.2.2 On-line Set (ONLN) for more details.

Trademarks

- HyperTerminal is either a registered trademark or a trademark of HILGRAEVE, INCORPORATED in the United States and/or other countries.
- IBM is a registered trademark of International Business Machines Corporation in the United States.
- Procomm Plus is either a registered trademark or a trademark of DATASTORM TECHNOLOGIES, INC. in the United States and/or other countries.
- Smartcom is either a registered trademark or a trademark of Hayes Microcomputer Products, Inc. in the United States and/or other countries.
- All other trademarks identified herein are the property of their respective owners.

TELEPHONE COMPANY AND F.C.C. REQUIREMENTS AND RESPONSIBILITIES

Notify The Telephone Company

Installation must be performed by a qualified professional installer. If required, provide the telephone company with the following technical information:

- *The telephone numbers to which the system will be connected*
- Make: Panasonic
- Model: KX-TVS50
- FCC Registration No.: found on the back of the unit
- Ringer Equivalence No.: 0.4B
- Facility Interface Code: 02LS2
- Service Order Code: 9.0F
- Required Network Interface Jack: RJ11C

Connection to the Telephone Line

The VPS unit must not be connected to coin operated telephone lines. Contact the telephone company before connecting this unit to a party line.

Telephone Service Problems

The telephone company may temporarily discontinue service if the VPS causes problems with the telephone network. Discontinued service usually occurs after prior notification. When prior notification is not practical, the telephone company must:

- *Promptly notify the customer of the temporarily discontinued service.*
- *Provide the customer with an opportunity to correct the situation or problem.*
- *Inform the customer of the right to bring a complaint to the Federal Communication Commission pursuant to the procedures set forth in Subpart E of Part 68 of the FCC Telephone Equipment Rules.*

Telephone Network and Terminal Equipment compatibility

Availability of Telephone Interface Information

When requested by the customer, the telephone company must provide the following information:

- *technical information concerning interface parameters.*
- *technical information not specified in FCC rules such as the number of ringers that can be connected to a particular telephone line.*

Changes in Telephone Company Communications Facilities, Equipment, Operations, and Procedures

The telephone company may make changes to its communication facilities, equipment, operations, or procedures, when such action is reasonably required in the operation of its business, and is not inconsistent with FCC rules (FCC Telephone Equipment Rules, Part 68).

The customer shall be given adequate notice in writing when changes will:

- *render the customer's equipment incompatible with telephone company communications*
- *require modification or alteration of customer terminal equipment*
- *materially affect customer terminal equipment use or performance*

Adequate notice provides the customer with the opportunity to make any necessary alterations in order to maintain uninterrupted service.

Note

This equipment has been tested and found to comply with the limits for a Class B digital device, pursuant to Part 15 of the FCC Rules. These limits are designed to provide reasonable protection against harmful interference in a residential installation. This equipment generates, uses and can radiate radio frequency energy and, if not installed and used in accordance with the instructions, may cause harmful interference to radio communications. However, there is no guarantee that interference will not occur in a particular installation. If this equipment does cause harmful interference to radio or television reception, which can be determined by turning the equipment off and on, the user is encouraged to try to correct the interference by one or more of the following measures.

- Reorient or relocate the receiving antenna.
- Increase the separation between the equipment and receiver.
- Connect the equipment into an outlet on a circuit different from that to which the receiver is connected.
- Consult the dealer or an experienced radio/TV technician for help.

Ringer Equivalence No. (REN)

Customers, before connecting terminal equipment to the telephone network, shall upon request of the Telephone Company, inform the Telephone Company of the particular line(s) to which such connection is made, the F.C.C. registration number (see the label on the back of the unit) and ringer equivalence number (REN) of the registered terminal equipment. The REN is useful in determining the quantity of devices you may connect to your telephone line and still have all of those devices ring when your telephone number is called. In most, but not all areas, the sum of the REN's of all devices connected to one line should not exceed five (5.0). To be certain of the number of devices you may connect to your line, as determined by the REN, you should contact your local telephone company to determine the maximum REN for your calling area.

CAUTION

Any change or modification made to the terminal equipment, not expressly approved by the manufacturer, could void the user's authority to operate this equipment.

When programming and/or making test calls to emergency numbers:

- *Remain on the line and briefly explain to the dispatcher the reason for the call.*
- *Perform these tests during off-peak hours, such as early morning or late evening.*

Table of Contents

1 VOICE PROCESSING SYSTEM OVERVIEW	
1.1 WHAT THE VPS CAN AND CANNOT DO	14
1.1.1 Why Voice Processing?	14
1.1.2 Basic Operations	14
1.1.3 VPS Limitations	15
1.2 SYSTEM ADMINISTRATION, MANAGEMENT, AND USE	16
1.2.1 System Administration	16
1.2.2 System Management	16
1.2.3 Subscriber Use	16
1.3 SYSTEM BASICS	17
1.3.1 General	17
1.3.2 System Components	17
1.3.3 Which Phone Systems are Compatible?	19
1.3.4 Installer Equipment and Software Requirements	20
1.3.5 Specifications	21
1.3.6 Hardware	21
1.3.7 Flash Memory Expansion Capabilities	21
1.3.8 Recommendations for System Configuration	21
1.4 DIGITAL INTEGRATION	23
1.4.1 General	23
1.4.2 APT Integration	23
1.4.3 Connection Example—APT Integration	23
1.4.4 DPT Integration	24
1.4.5 Connection Example—DPT Integration	24
2 INSTALLATION	
2.1 SAFETY PRECAUTIONS	26
2.1.1 Installation	26
2.1.2 Wiring	27
2.2 UNPACKING	28
2.3 MOUNTING THE VPS ON THE WALL	29
2.4 FRAME GROUND CONNECTION	30
2.5 INSTALLATION STEPS	31
2.6 INSTALLING AN OPTIONAL EXPANSION MEMORY CARD	33
2.6.1 General	33
2.6.2 Installing the KX-TVS52	33
2.7 CONNECTIONS	35
2.7.1 Connecting to the PBX	35
2.7.2 Opening the Ferrite Core	35
2.7.3 Connection for APT Integration	36
2.7.4 Connection for DPT Integration	36
2.7.5 Connection for Non-APT/DPT Integration	37
2.8 TERMINAL CONNECTION	38
2.8.1 Requirements for Connecting Programming Terminal	38
2.8.2 Connecting the RS-232C Cable	38
2.8.3 RS-232C Signals	40

3	INTEGRATING THE VPS WITH PANASONIC KX-T PHONE SYSTEMS	
3.1	GUIDELINES FOR INTEGRATION	42
3.1.1	APT/DPT or Inband Signaling?	42
3.1.2	Why Integration is Important	42
3.1.3	How the VPS and the PBX Communicate	42
3.1.4	PBX Requirements for Integration	43
3.2	PBX PARAMETERS AND PORT SETTINGS	46
3.2.1	General Guidelines and Definitions	46
3.2.2	RS-232C Settings	46
3.2.3	Port Settings	46
3.2.4	PBX Interface Parameters	47
3.3	CONNECTING THE VPS WITH PANASONIC KX-T SERIES PBXs	50
3.3.1	VPS Programming for Inband Integration	50
3.3.2	KX-T123211D Software Verification and Programming for Inband Integration	51
3.3.3	KX-TA Series Programming for Inband Integration via the Manager's Extension	53
3.3.4	KX-TD816, KX-TD1232, KX-TA1232 and KX-TD308 Programming for Inband Integration via the Manager's Extension	56
3.3.5	KX-TD816, KX-TD1232, and KX-TA1232 Programming for Inband Integration via the Operating and Maintenance Tool	56
3.3.6	KX-TD308 Programming for Inband Integration via the Operating and Maintenance Tool	60
4	INTEGRATING THE VPS WITH THE PANASONIC KX-TA SERIES PBX AND KX-TD SERIES PBX	
4.1	GUIDELINES FOR DIGITAL INTEGRATION	66
4.1.1	Why Digital Integration is Important	66
4.2	CONNECTING THE VPS WITH THE PANASONIC KX-TA624	68
4.2.1	KX-TA624 Software Verification and Programming for Digital Integration via the Manager's Extension	68
4.3	CONNECTING THE VPS WITH THE PANASONIC KX-TD816, KX-TD1232, KX-TA1232 AND KX-TD308	74
4.3.1	KX-TD1232 Software Verification and Programming for DPT Integration via the Manager's Extension	74
4.3.2	KX-TD1232 Software Verification and Programming for DPT Integration via the Operating and Maintenance Tool	79
4.3.3	KX-TD308 Software Verification and Programming for DPT Integration via the Manager's Extension	82
4.4	COMMON DIGITAL INTEGRATION FEATURES AND SETUP PROCEDURES	87
4.4.1	Live Call Screening (LCS) Programming	87
4.4.2	Live Call Screening Password Assignment	87
4.4.3	Live Call Screening Password Canceling	88
4.4.4	Live Call Screening Recording Mode Assignment via System Programming	88
4.4.5	Live Call Screening Private/Hands-Free Mode Assignment via Station Programming	89
4.4.6	Live Call Screening Button Assignment via Station Programming	90
4.4.7	Live Call Screening Cancel Button Assignment via Station Programming	90
4.4.8	Two-Way Recording Button Assignment via Station Programming	91
4.4.9	Two-Way Transfer Button Assignment via Station Programming	92
4.4.10	Voice Mail Transfer Button Assignment via Station Programming	92

4.4.11	Live Call Screening Activation	93
4.4.12	Live Call Screening Password Control.....	94
4.4.13	Two-Way Recording into Mailbox	94
4.4.14	Two-Way Transfer into Mailbox	94

5 CUSTOMIZING THE SYSTEM

5.1	STARTING UP	96
5.1.1	Before Programming	96
5.1.2	Quick Setup	96
5.1.3	Starting the Quick Setup.....	97
5.2	PORT SETTING OPTIONS.....	104
5.2.1	Custom Service Setting Example	104
5.2.2	Custom Service Features	105
5.2.3	Custom Service Programming.....	106
5.2.4	Recording Menus.....	110
5.2.5	Checking Operation.....	110
5.2.6	Voice Mail.....	110
5.2.7	Mailbox Groups.....	111
5.2.8	Extension Groups	111
5.2.9	Interview Service.....	112
5.2.10	Automated Attendant.....	113
5.2.11	Department Dialing Service	113
5.2.12	Operator Service	114
5.3	SETTING PORTS	115
5.3.1	Port Service Menu	115
5.4	AUTOMATED ATTENDANT PARAMETERS.....	117
5.4.1	Automated Attendant Menu	117
5.4.2	Department Dialing	117
5.4.3	Operator's Parameters	118
5.5	SETTING MAILBOXES.....	121
5.5.1	Mailbox Setting Menu.....	121
5.5.2	Entering a Mailbox	121
5.5.3	Deleting a Mailbox	125
5.5.4	Password Reset.....	125
5.5.5	Mailbox Listing	126
5.6	TRAINING THE SUBSCRIBER.....	127

6 FINAL SETUP

6.1	MESSAGE MANAGER'S MAILBOX (Mailbox 998).....	130
6.1.1	Accessing the Message Manager's Mailbox	130
6.1.2	Main Menu of Message Manager's Service	130
6.1.3	Custom Service Greetings (Enter #6*998,5,4).....	131
6.1.4	Customizing User Prompts (Enter #6*998,5,6)	131
6.2	SETTING UP MAILBOXES.....	132
6.2.1	Recording Personal Greetings	132
6.2.2	Recording the Owner's Name	133
6.3	BACKING UP THE SYSTEM.....	134

7 SYSTEM MAINTENANCE AND TROUBLESHOOTING

7.1	INITIALIZING THE SYSTEM	138
7.2	UTILITY COMMANDS.....	140
7.2.1	Off-line Set (OFLN).....	141
7.2.2	On-line Set (ONLN).....	141
7.2.3	Set Password (PASS).....	141
7.2.4	Set Time (TIME).....	142
7.2.5	Print Reports at Specified Time (PSET)	143
7.2.6	Error Log Display (ELOG)	144
7.2.7	Saving the System Data to the Backup Device (SAVE)	146
7.2.8	Loading New or Saved Data to the VPS (LOAD)	148
7.2.9	Print All of the VPS Parameters (GPRN)	149
7.2.10	Program Version Display (VERS).....	149
7.2.11	Custom Service Report (CREP)	150
7.2.12	Custom Service Menu Access Count Clear (CCLR)	151
7.2.13	Message Waiting Lamp Retry Times (MWL).....	151
7.2.14	Setting Minimum Recording Length (MRL)	152
7.2.15	Modified Prompt List (MPLT)	152
7.2.16	Utility Command List (HELP).....	153
7.2.17	Quick Setup (QSET)	154
7.2.18	Circuit Condition Display (LMON).....	154
7.2.19	Touchtone Information Display (PUTD)	154
7.2.20	Wait for Caller ID (WCID)	156
7.3	SYSTEM REPORTS.....	157
7.3.1	Mailbox Assignments.....	158
7.3.2	COS (Class of Service) Assignments.....	158
7.3.3	System Service Report	160
7.3.4	Call Account Report.....	160
7.3.5	Port Usage Report	161
7.3.6	Port Usage Statistics Clear	162
7.3.7	Flash Memory Usage Report.....	162
7.3.8	Flash Memory Usage Statistics Clear	163
7.3.9	Mailbox Usage Report	163
7.3.10	Mailbox Usage Statistics Clear	164
7.3.11	Fax Call Report.....	165
7.3.12	Fax Call Statistics Clear	165
7.4	TROUBLESHOOTING GUIDE	167
7.5	SPECIFICATIONS	171

Appendix A SYSTEM FEATURES

A1	SYSTEM FEATURES.....	174
-----------	-----------------------------	------------

Appendix B SYSTEM ADMINISTRATOR'S GUIDE

B1	SYSTEM NAVIGATION	204
B2	SYSTEM ADMINISTRATION—MAILBOXES	208
B3	SYSTEM ADMINISTRATION—SETTING COS (CLASS OF SERVICE) PARAMETERS.....	215
B4	SYSTEM ADMINISTRATION—PORT/TRUNK SERVICE	225
B4.1	Port Assignment	225

B4.2	Trunk Group Assignment.....	227
B5	SYSTEM ADMINISTRATION—SERVICE SETTINGS	230
B5.1	Automated Attendant Parameters	230
B5.2	Custom Service	238
B5.3	Caller ID Call Routing Parameters	241
B6	SYSTEM ADMINISTRATION—SYSTEM PARAMETER SETTINGS	244
B6.1	System Group Assignment	244
B6.2	Time Service	247
B6.3	Holiday Setting	251
B6.4	Daylight Saving Time (DST).....	253
B6.5	Prompt Setting	254
B6.6	System Caller Name Announcement.....	256
B6.7	Other Parameters.....	257
B7	SYSTEM ADMINISTRATION—HARDWARE SETTINGS	269
B7.1	RS-232C Parameters.....	269
B7.2	Port Setting	270
B7.3	PBX Interface Parameters.....	271
 Appendix C SYSTEM MANAGER'S GUIDE		
C1	ACCESSING THE SYSTEM MANAGER'S MAILBOX.....	280
C2	SETTING UP MAILBOXES.....	281
C3	SETTING COS (CLASS OF SERVICE) PARAMETERS.....	284
C4	SETTING THE SYSTEM CLOCK.....	291
C5	CHANGING THE SERVICE MODE SETTING.....	293
C6	CHECKING SYSTEM USAGE (SYSTEM REPORTS).....	295
C7	DELIVERING MESSAGES.....	297
C8	CUSTOMIZING THE SYSTEM MANAGER'S MAILBOX	300
C9	LISTENING TO SYSTEM MANAGER MESSAGES	301
 Appendix D MESSAGE MANAGER'S GUIDE		
D1	ACCESSING THE MESSAGE MANAGER'S MAILBOX.....	304
D2	MANAGING THE GENERAL DELIVERY MAILBOX	305
D3	SETTING UP MESSAGE WAITING NOTIFICATION	307
D4	CUSTOMIZING THE MESSAGE MANAGER'S MAILBOX	310
D5	SETTING THE SYSTEM CLOCK.....	312
D6	RECORDING MESSAGES.....	314
D7	REMOTE CALL FORWARDING SET.....	319
D8	LIST OF PROMPTS FOR VOICE MAIL AND AA SERVICE.....	322
D9	LIST OF MODIFIABLE PROMPTS	325
Glossary		377
INDEX.....		387

Section 1

VOICE PROCESSING SYSTEM OVERVIEW

1.1 WHAT THE VPS CAN AND CANNOT DO

1.1.1 Why Voice Processing?

The VPS handles incoming and outgoing calls. When a call comes in, it answers, forwards to appropriate extensions, takes and stores messages, and notifies subscribers when messages are left. Subscribers may send and transfer messages to other subscribers within the system. The VPS is easy to use, helping callers through the system with step-by-step voice prompts.

Unlike handwritten messages or those left with answering services, VPS messages are confidential; they are stored in a mailbox and retrieved only with the subscriber's password. Other advantages of the VPS are clarity and accuracy, which are commonly lacking with written messages. The messages come directly from the caller, in the caller's own voice. To further ensure accuracy, the system allows the sender to correct or change messages before saving them. Messages can be erased or transferred by the recipient.

1.1.2 Basic Operations

Greeting Callers:

The VPS greets callers with a prerecorded message that includes directions for leaving and editing messages. The VPS can list single-digit numbers for each available extension or mailbox. Callers who know the extension of the person they wish to reach may dial the extension number at any time. Callers with rotary phones are transferred to a preprogrammed destination (which is often an operator or the General Delivery Mailbox) to leave a message.

Sending Messages:

Callers can review and edit messages before leaving them in a mailbox. Subscribers can send messages to an individual or to several mailboxes at once. The message sender can then verify that the other subscriber has received the message.

Receiving Messages:

There are several different message notification methods that subscribers can use. They can choose to be notified by message waiting lamp, beeper, or a call from the system to another line. System programming determines whether a subscriber will be notified each time a message is left. (Subscribers can choose to receive message notifications differently depending on the time of day.) Mailbox parameters, which accommodate 5-100 messages, determine the maximum length of messages. If the system is connected using Digital Integration, subscribers can press a pre-assigned button to record conversations into their own mailboxes or other subscribers' mailboxes while talking on the phone. Digital Integration also allows subscribers to screen messages as they are being left, or intercept them if required.

1.1.3 VPS Limitations

The VPS does not support:

UCD functions

UCD (Uniform Call Distribution) is a service that distributes calls evenly among extensions; when all extensions are unavailable, it returns to callers to say that all extensions are busy. Calls can be forwarded by the VPS to the KX-TD1232/816/308 floating number of a UCD group. The call then rings at the next available phone.

The VPS supports UCD functions with very limited capabilities. Because the incoming call is forwarded as an intercom path and not a DIL (direct in line), the following items will not work:

- *time table*
- *overflow function*
- *DISA message from a DISA card*
- *IRNA*

Integration with the wrong PBX or with certain Key Systems presents limitations to the VPS' standard functions. We do not recommend these systems for integration with the VPS. The section 1.3.3 Which Phone Systems are Compatible? explains problems with compatibility.

1.2 SYSTEM ADMINISTRATION, MANAGEMENT, AND USE

1.2.1 System Administration

System Administration is accomplished by the installer using terminal emulation software. It concerns setting and changing system parameters and diagnosing system problems.

1.2.2 System Management

Two system functions are performed by the customer: System Management and Message Management.

System Management concerns changing system parameters through the System Manager's Mailbox.

Message Management concerns recording voice prompts through the Message Manager's Mailbox. These messages include Department Dialing menu, Custom Service menus, voice labels for System Group Distribution Lists, user prompts, multilingual selection menu and System Caller Names.

1.2.3 Subscriber Use

System users are called subscribers. Subscribers are assigned personal mailboxes which they can customize. Subscribers can record their names, record personal greetings, set covering extensions, record questions for an interview mailbox, set the message reception mode, set incomplete call handling status, set call transfer status, enter Personal Group Distribution Lists, set the message waiting lamp, and set notification by calling.

1.3 SYSTEM BASICS

1.3.1 General

The KX-TVS50 is initially configured with 2 ports and 2 h of storage.

1.3.2 System Components

Main Cabinet

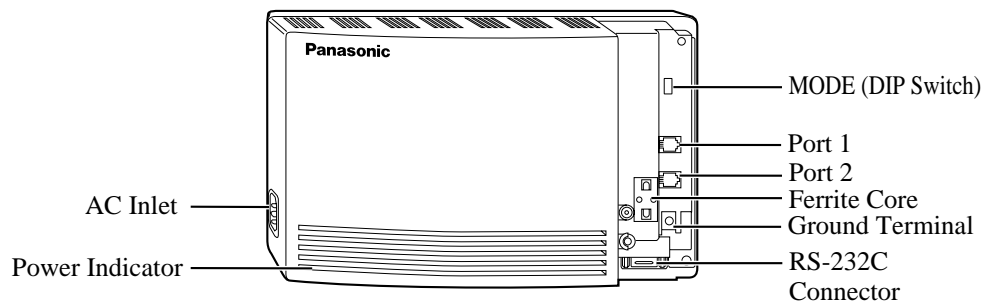

Note

EIA port is at SELV.

Inside View of the Main Cabinet

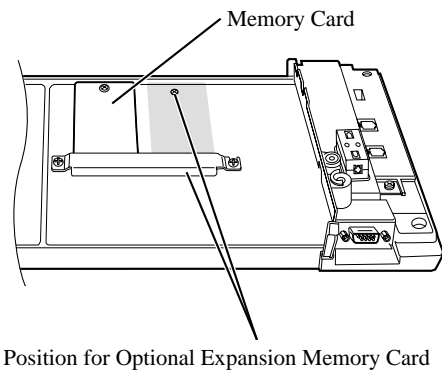

System Components

AC Inlet:

Connects the power cable to an AC outlet dedicated to the VPS.













Power Indicator:

Indicates the system status: when flashing, the system is off-line (not ready to receive calls).

MODE (DIP Switch):

By setting one of the following positions and executing power down and up, you can achieve a desired result:

Table 1

Position	Additional Function
0 	Normal setting. (All switches in 0 position.)
1 	Initializes RS-232C parameters. RS-232C default parameters: 9,600, N, 8, 1
2*1 	Auto Configuration is automatically executed and all ports are set for Automated Attendant service.
3*1 	Auto Configuration is automatically executed and all ports are set for Voice Mail service.
4	Reserved.
5 	Initializes the VPS. Clears all voice data (except User 1 and User 2 prompts) and returns all system parameters to the default setting.
6 	Test Mode (Flash Memory Read/Write Test)
7	Reserved.
8 	Initializes the VPS. Clears all voice data and returns all system parameters to the default setting. CAUTION: User 1 and User 2 Prompts will be erased!
9	Reserved.
10*2 	Auto Configuration is automatically executed and all ports are set for Automated Attendant service.
11*2 	Auto Configuration is automatically executed and all ports are set for Voice Mail service.
12 	All service prompts are set to System Prompts.
13 	All service prompts are set to User 1 Prompts.
14 	All service prompts are set to User 2 Prompts.
15	Reserved.

*¹ For Panasonic KX-T series telephone systems with DPT Integration.

*² For Panasonic KX-TA624 telephone system with APT Integration.

To change the position, use a pointed object, such as a pen, etc.

When setting the DIP Switch to any position (except 0):

1. Disconnect the station wire(s) and wait a few minutes.

2. Disconnect the AC cord from the VPS.

3. Set the DIP Switch.

4. Connect the AC cord to the VPS.

5. Connect the station wire(s) to the VPS and wait approximately 3.5 min.

6. Return the DIP Switch to position 0.

Ground Terminal:

Should be connected to a ground source with less than 1 Ω resistance.

RS-232C Connector:

Connects an ASCII or VT terminal to the VPS that is necessary to program the system.

Memory Card:

(One/system) Stores the proprietary system program, and the voice prompts (about 30 min worth); has the capacity to record approximately 2h of messages from callers.

1.3.3 Which Phone Systems are Compatible?

We recommend integration with the following Panasonic phone systems:

- *Panasonic KX-TA624*
- *Panasonic KX-TD308*
- *Panasonic KX-TD1232*
- *Panasonic KX-TD816*
- *Panasonic KX-TA1232*
- *Panasonic KX-T336*
- *Panasonic KX-T123211D*

We cannot guarantee adequate integration of the VPS with other PBX systems or with Key Systems. If the customer does not have a recommended Panasonic PBX system, be sure that the system has the features listed below.

The PBX should have the following features for successful integration:

- *Single line (tip/ring) port circuits (Some PBXs need an OPX card to provide this connection.)*
- *Station to station touchtone signaling*

- *Message Waiting Notification from an SLT (single-line telephone)*
- *Screened transfer from an SLT*
- *Message Waiting Notification on proprietary (multi-line) sets (message waiting lamp accessed by dialing on/off codes)*

If the PBX does not have these features, VPS operation will be limited.

See 3.1.4 PBX Requirements for Integration. You will find the following information about each feature listed:

- *Description*
- *Limitations of the system without the feature*
- *Tests to determine whether the PBX has the feature*

VOICE MAIL

The recommended Panasonic PBX systems have Follow-on ID and Inband Integration. When callers are transferred to an extension that is forwarded to Voice Mail, Follow-on ID sends callers directly to the mailbox. Without Follow-on ID, the caller would have to re-enter the mailbox number when connected to Voice Mail.

Touchtone Integration enables the VPS to recognize the current state of the call and improve its call handling performance. When enabled, the PBX informs the VPS of the status of the call (busy, answered, ringing, etc.) by sending a code with touchtones before sending the normal call progress tones. For example, when a caller hangs up before making a selection, the PBX sends # 9 to the VPS port that answered. This informs the VPS that the caller has hung up. Upon receiving these digits, the VPS goes on-hook and is ready to handle another call.

Digital (APT/DPT) Integration is available when the VPS is connected to a Panasonic KX-TA624 or other Panasonic KX-T series digital PBX (depending on the software version). This Digital Integration provides the VPS with more information than Touchtone Integration. This information enables the system to identify the extension number of the caller, know where from and why the call is forwarded, and recognize what the caller wants to do. Some features are available only with Digital Integration (Remote Call Forwarding Set, Live Call Screening, Two-Way Recording, Two-Way Transfer, Direct Mailbox Access, Intercom Paging, Auto Configuration, Caller Name Announcement [system/personal], Caller ID Call Routing, Personal Greeting for Caller ID, Time Synchronization with PBX).

1.3.4 Installer Equipment and Software Requirements

The installer **must** have a personal computer or data terminal equipped with terminal emulation software. We suggest that you use something like HyperTerminal by HILGRAEVE. Use the personal computer to program the VPS. Terminal emulation software enables the keyboard to be used as a data entry device.

While both the personal computer and data terminal are working, the personal computer allows screens to be saved in a file throughout the process. It is often helpful to retrieve these files later if technical support is needed.

1.3.5 Specifications

Table 2

Ports:	2 ports
Voice Storage (approximate):	2 h
Custom Services:	100
Message Retention:	1 to 30 days or unlimited
Number of Mailboxes:	30 Subscriber and 2 Manager Mailboxes
Number of Messages per Mailbox:	100 maximum (programmable)

1.3.6 Hardware

- *1 Flash Memory Card.*
- *1 Optional Flash Memory Position for KX-TVS52 card*
- *2 Telephone Inputs (RJ11C)*
- *1 RS-232C Connector*
- *1 DIP Switch (4-bit)*

1.3.7 Flash Memory Expansion Capabilities

Expansion of the flash memory capacity requires an optional expansion memory card (KX-TVS52). The KX-TVS50 initially has 2 h memory. The KX-TVS52 increases the capacity by 2 h.

1.3.8 Recommendations for System Configuration

General guideline: a ratio of 6/1 (for every 6 lines, 1 port). There are 2 questions to ask when considering how many ports are desirable:

- Are the ports answering all incoming calls or just forwarded/transferred calls?
- If they are answering incoming calls, how busy are the lines?

The guideline above (6/1) usually works well with moderate traffic. However, this may have to be modified for heavy traffic. Recommendations are outlined in the following charts.

Table 3

CO Lines	Port
1-6	1
7-12	2

One port may not support an Automated Attendant configuration with 5 CO lines. The preceding recommendations for Automated Attendant ports may have to be modified for heavy traffic.

Table 4

CO Lines	Port
1-4	1
5-8	2

1.4 DIGITAL INTEGRATION

1.4.1 General

There are 2 types of Digital Integration: APT Integration and DPT Integration. APT Integration is available when the VPS is connected to a KX-TA624. DPT Integration is available when the VPS is connected to a KX-TD or KX-TA1232 digital PBX.

1.4.2 APT Integration

To the Panasonic KX-TA624, the VPS ports look like proprietary telephones. The PBX thinks that the VPS is a proprietary telephone, and the VPS mimics all actions of a proprietary telephone. Communication between the VPS and the PBX through digital integration requires the proper software level in the PBX and 4-wire connections for each port. To communicate between the VPS and the PBX through APT Integration, the PBX and VPS must be programmed to work together.

1.4.3 Connection Example—APT Integration

For example, you can connect jack 7 of the KX-TA624 to Port 1 of the VPS with a 4-wire connection (see diagram below). This connection creates 1 Voice Mail extension and can only answer 1 call. This means that a fully-configured 2-port system requires 2 jacks from the PBX.

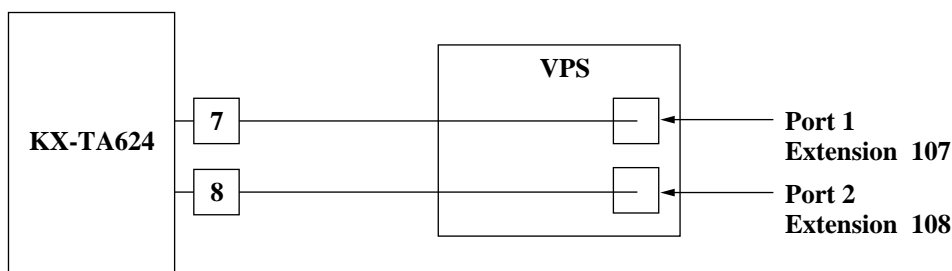

When APT Integration is activated, a single extension jack provides 1 single-line interface at a Port on the VPS. For example, when 1 line cord (4 wire) is connected to Port 1 on the VPS, 1 extension is provided.

1.4.4 DPT Integration

To the Panasonic KX-T series PBX that uses DPT Integration, the VPS ports look like digital extensions. The PBX thinks that the VPS is a digital phone, and the VPS mimics all actions of a digital set. Another advantage of digital integration is that the 2B+D communication provides 2 VPS ports for each Digital Station port. Communication between the VPS and the PBX through digital integration requires the proper software level in the PBX and 4-wire connections for each port. To communicate between the VPS and the PBX through DPT Integration, the PBX and VPS must be programmed to work together.

1.4.5 Connection Example—DPT Integration

For example, you can connect jack 15 of the KX-TD1232 to Port 1 of the VPS with a 4-wire connection (see diagram below). This connection creates 2 Voice Mail extensions and can simultaneously answer 2 calls. This means that a fully-configured 2-port system requires only 1 jack from the PBX.

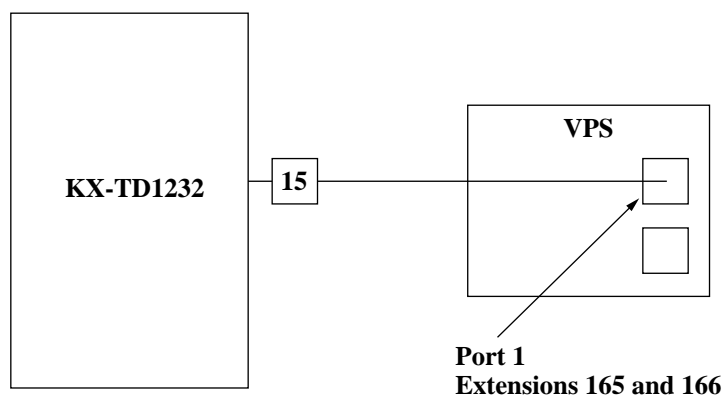

When DPT Integration is activated, a single extension jack provides 2 single-line interfaces at a Port on the VPS. For example, when 1 line cord (4 wire) is connected to Port 1 on the VPS, 2 extensions are provided.

Section 2
INSTALLATION

2.1 SAFETY PRECAUTIONS

Please read the following precautions before installing the VPS.

2.1.1 Installation

The VPS needs to be mounted on a wall. Improper placement of the system may result in malfunction, noise, or discoloration. Avoid installing the VPS in the following places:

- *in direct sunlight; in hot, cold, or humid places*
- *in new areas where there are thermal springs, etc. (where sulfuric gas may damage the equipment or contacts).*
- *where shocks or vibrations are frequent or strong.*
- *in dusty places or places where water or oil may come in contact with the unit.*
- *near high frequency generating devices such as sewing machines, elevators or electric welders.*
- *on or near computers, telexes, or other office equipment; near microwave ovens or air conditioners. (Ideally, the VPS should not be in the room with these items and should be at least 1.8 m {6 feet} away from televisions.)*

Do not obstruct the areas around the PBX and the VPS. Both require space above for cooling and space on the sides for maintenance and inspection.

2.1.2 Wiring

- *To assure good quality telephone connection, it is recommended new and modifications to existing installation of customer premise wiring shall use solid twisted pair copper conductors with minimum 24 gauge that comply with the electrical specifications for Category 3 wiring as detailed in ANSI/EIA/TIA-570A Building Wiring Standards.*
- *Do not wire the telephone cable parallel to an AC power source, computer, etc. If cables are run near those wires, shield them with metal tubing or use shielded cables and ground the shields.*
- *Use protectors if running cables on the floor. Avoid running cables under carpets.*
- *Avoid sharing a 120 V AC power supply for computers, telexes, and other office equipment with the VPS. Induction noise from such equipment may interrupt the VPS operation.*

When making any connections or removing the cover, be sure the power switch is turned off.

When installing telephone wiring, basic safety precautions should always be followed to reduce the risk of fire, electric shock and injury to persons, including the following:

- Never install telephone wiring during a lightning storm.
- Never install telephone jacks in wet locations unless the jack is specifically designed for wet locations.
- Never touch uninsulated telephone wires or terminals unless the telephone line has been disconnected at the network interface.
- Use caution when installing or modifying telephone lines.

Note

If you live in an area that can have frequent power failures, we strongly recommend that you purchase a suitable UPS (uninterruptible power supply) for your VPS (and PBX if needed). The power rating of your VPS may be found in the specifications.

2.2 UNPACKING

Unpack the box and check the items below.

Table 5

Main Unit	1
AC Cord	1
Screws (Wall Mounting)	3
Anchor Plugs (Wall Mounting)	3

2.3 MOUNTING THE VPS ON THE WALL

The wall where the VPS is to be mounted must be able to support the weight of the VPS. If screws other than the ones supplied are used, use the same-sized diameter screws as the enclosed ones.

To Mount on a Wooden Wall:

1. Place the template (included) on the wall to mark the 3 screw positions.

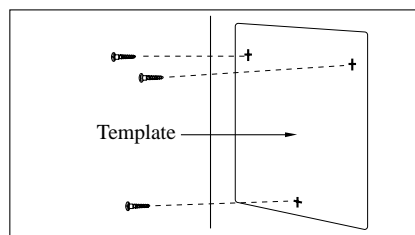

2. Install the 3 screws (included accessories) into the wall.

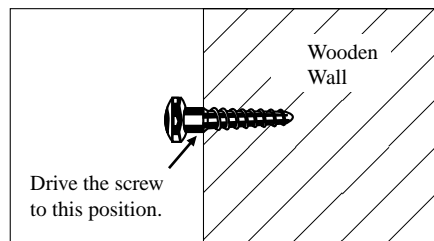

3. Hook the unit on the screw heads.

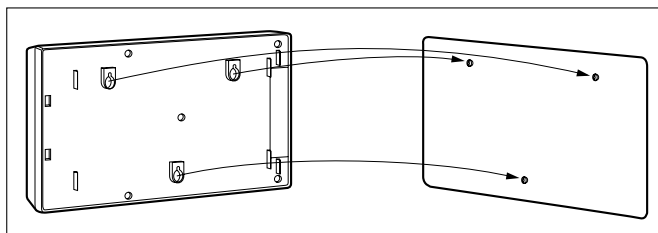

2.4 FRAME GROUND CONNECTION

IMPORTANT!!!

Connect the frame of the main unit to the ground.

1. Loosen the screw.
2. Insert the grounding wire.
3. Tighten the screw.
4. Connect the grounding wire to the ground.

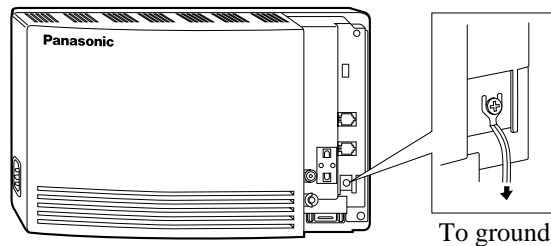

In most of North America, the ground provided by the "Third wire ground" at the commercial or residential power outlet will be satisfactory. However, in some cases this ground may be installed incorrectly. Therefore, the following test procedure should be performed.

Test Procedure

1. Obtain a suitable voltmeter and set it for a possible reading of up to 250 V AC.
2. Connect the meter probes between the 2 main AC voltage points on the wall outlet. The reading obtained should be 108 V AC-132 V AC.
3. Move one of the meter probes to the third prong terminal (GND). Either the same reading or a reading of 0 V should be obtained.
4. If a reading of 0 V at 1 terminal and a reading of 108 V AC-132 V AC at the other terminal is not obtained, the outlet is not properly grounded. This condition should be corrected by a qualified electrician (per article 250 of the National Electrical Code).
5. If a reading of 0 V at 1 terminal and a reading of 108 V AC-132 V AC at the other terminal is obtained, then set the meter to the "OHMS/RX1" scale, place 1 probe at the GND Terminal and the other probe at the terminal which gave a reading of 0 V. A reading of less than 1 Ω should be obtained. If the reading is not obtained, the outlet is not adequately grounded. See a qualified electrician.

2.5 INSTALLATION STEPS

The following is an overview of the standard installation process using Digital Integration. When necessary, other sections in this manual have been referenced for more detailed descriptions or instructions.

1. Obtain a list of current users, their extension numbers, their departments, and the type of systems they use (mailbox, no mailbox, beeper, car phone, etc.).
2. Assess your customers' needs before setting up the system. You will save yourself time later by giving customers what they need up front. Ask the office manager how the VPS will be used. Give examples.
Recommend that your customer use a word processor to log the greetings. You will find these files much more easily than the worksheet pages if you need to make changes down the road.
3. Connect the power cord to the VPS.

CAUTION

The power supply cord is used as the main disconnect device. Ensure that the socket-outlet is located/installed near the equipment and is easily accessible.

4. Standard Initialization (For Digital Integration Connection)
 - a) Program the ports of the PBX for voice processing (see Section 4 INTEGRATING THE VPS WITH THE PANASONIC KX-TA SERIES PBX AND KX-TD SERIES PBX).
Program the KX-TA624, the KX-TD1232, the KX-TA1232, the KX-TD816 or the KX-TD308 for Voice Mail integration.
 - KX-TA624
 - KX-TD816, KX-TD1232, KX-TA1232, KX-TD308

Program may be performed on-site or at the office.

All memory is stored and will be retained when the unit is powered up as long as the DIP Switch has been reset to position [0] prior to turning the unit off.

- b) Unplug the power cord of the VPS.
- c) Plug station wire(s) from the PBX into VPS (see 2.7 CONNECTIONS).
- d) Connect the personal computer to the VPS with a Null Modem Cable (see 2.8.2 Connecting the RS-232C Cable).
- e) Set the DIP Switch to position 5.
- f) Plug in the power cord of the VPS.
- g) Wait until the "warning" appears on the screen.
- h) Set the DIP Switch back to position 0.

CAUTION

If the DIP Switch is not reset to position 0 after initialization, all programming will be lost when the voice processor loses power!

5. Perform Quick Setup (see Section 5 CUSTOMIZING THE SYSTEM).

6. Check Quick Setup:

- The Power Indicator on the Voice Processor should be solid.
- The screen output should be: [On Line].

If you do not see the "On Line" message, check the following:

- The line cord to the Voice Processor has 4 conductors.
- The programming on the KX-TA624 is correctly set in System Program [130], or [130] and [131].
- The programming on the KX-TD816, KX-TD1232, KX-TA1232 or KX-TD308 is correctly set in System Program [117].

7. Set up Class of Service (COS) for each user. Customize voice prompts if necessary (see Appendix B SYSTEM ADMINISTRATOR'S GUIDE).

8. Perform Administrative Program through a personal computer (see Appendix B SYSTEM ADMINISTRATOR'S GUIDE).

CAUTION

*Do not turn the power off while the VPS is activated so as not to cause malfunction.
To turn the power off after installing the VPS, unplug the power cord from the VPS a few minutes after disconnecting station wire(s).*

2.6 INSTALLING AN OPTIONAL EXPANSION MEMORY CARD

2.6.1 General

The flash memory capacity of the KX-TVS50 can be increased from 2 h to 4 h if an optional expansion memory card (KX-TVS52) is installed.

2.6.2 Installing the KX-TVS52

1. Disconnect the station wire(s). Wait a few minutes, and then disconnect the AC cord from the VPS.
2. Take out the screw.

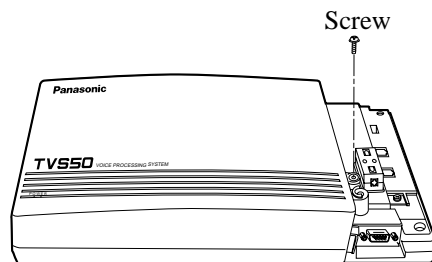

3. Remove the cover by pressing both tabs and lifting up.

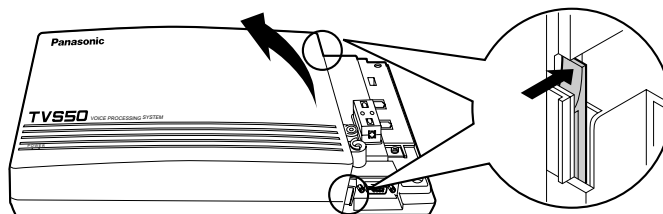

4. Take out the screws and remove the metal bar.

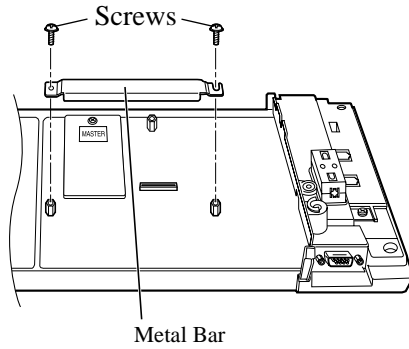

5. Attach the optional expansion memory card firmly. Secure the screw.

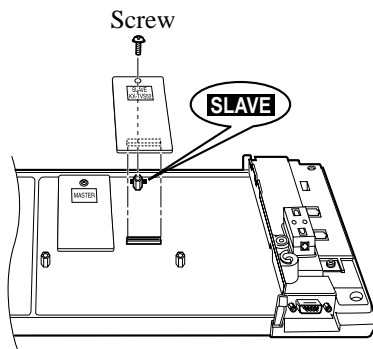

CAUTION

Do not attach the optional expansion memory card at the "MASTER" position. Attach it at the "SLAVE" position.

6. Replace the metal bar and secure the screws.

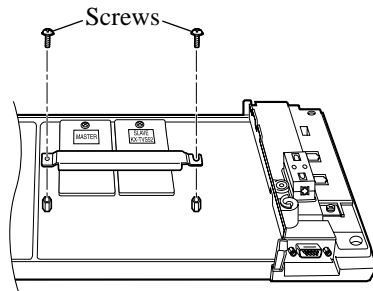

7. Replace the cover and secure the screw.

8. Connect the AC cord to the VPS again.

2.7 CONNECTIONS

2.7.1 Connecting to the PBX

The VPS can be connected to up to 2 extension ports of the PBX. Use a 4-conductor wire for connection with KX-TA624 that uses APT Integration, and for connection with KX-T series systems that use DPT Integration. Use a 2-conductor wire for connection to all other PBXs.

4-Conductor Cable

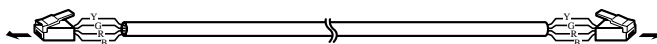

Modular Connection

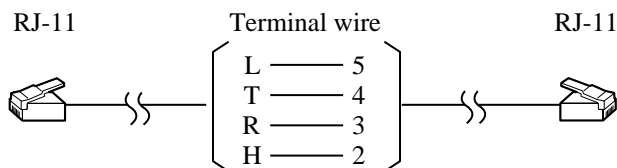
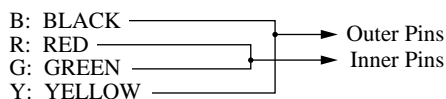

2.7.2 Opening the Ferrite Core

Insert your finger into the opening of the ferrite core and open it as shown below:

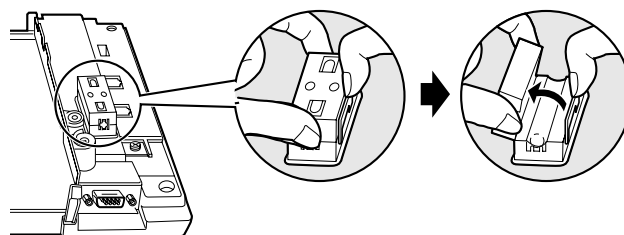

Connect a 4-conductor cable or 2-conductor cable to the VPS and run the cable through the ferrite core (see the following sections). Close the ferrite core.

2.7.3 Connection for APT Integration

Ports 1-2 of the VPS

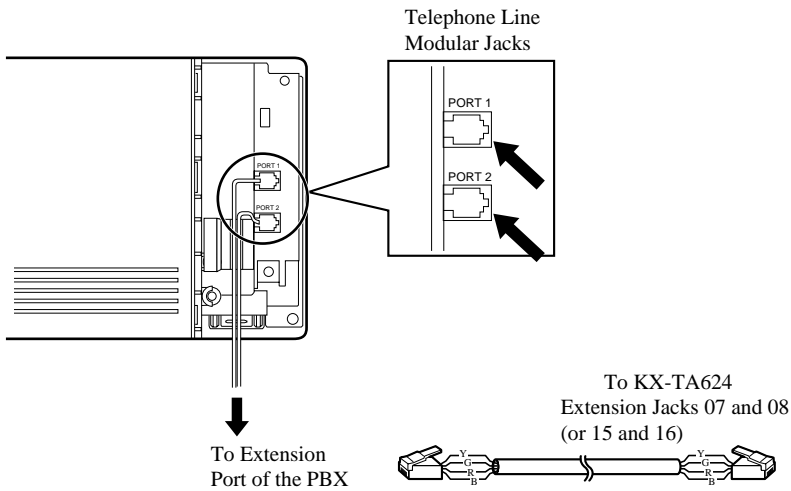

2.7.4 Connection for DPT Integration

Ports 1-2 of the VPS

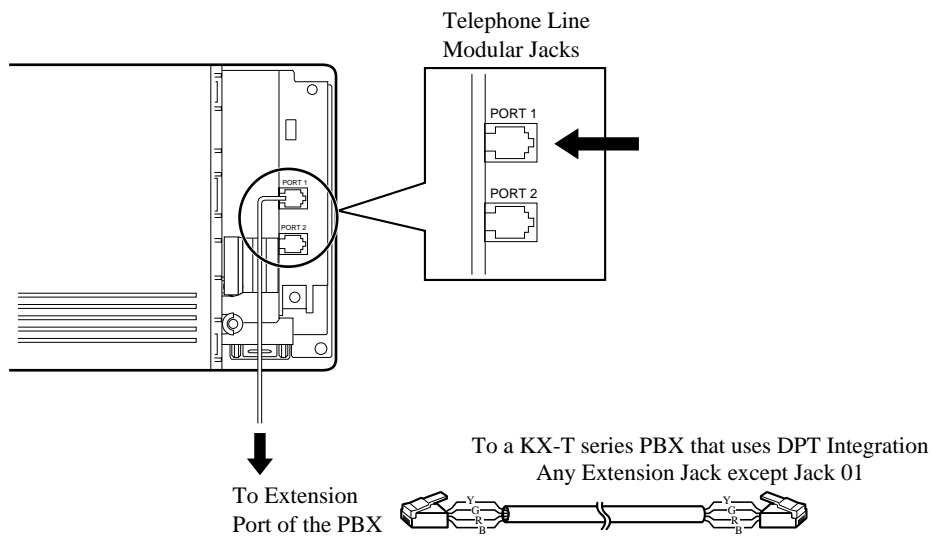

2.7.5 Connection for Non-APT/DPT Integration

Ports 1-2 of the VPS

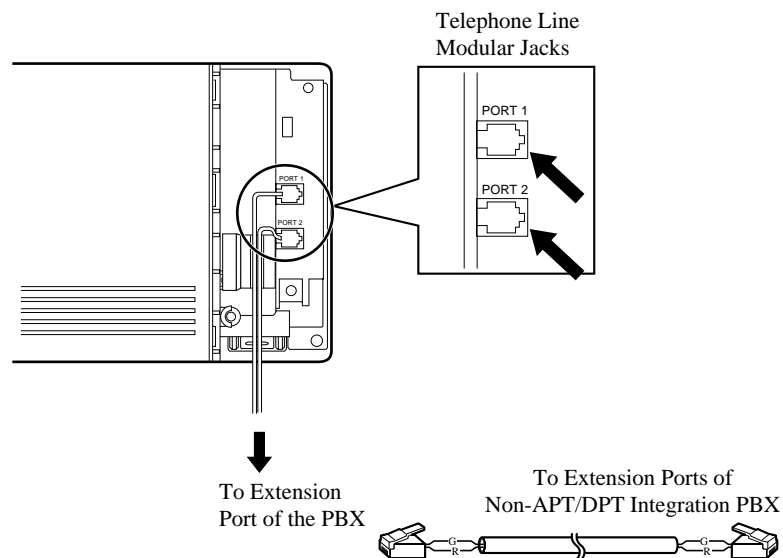

2.8 TERMINAL CONNECTION

2.8.1 Requirements for Connecting Programming Terminal

The programming terminal must be connected with a serial cable with an RS-232C connector at the RS-232C port. This must be a null modem cable. This enables system administration (system setup, mailbox setup, and system diagnosis) to be performed.

Communication parameters of the VPS have been set to the following values at the factory:

Table 6

COMMUNICATION PARAMETERS	
Baud Rate:	9600 bps
Word Bit Length:	8 Bits
Parity:	None
Stop Bit Length:	1 Bit

2.8.2 Connecting the RS-232C Cable

RECOMMENDED:

Before connecting the cable, switch off the power on both the data terminal and the VPS.

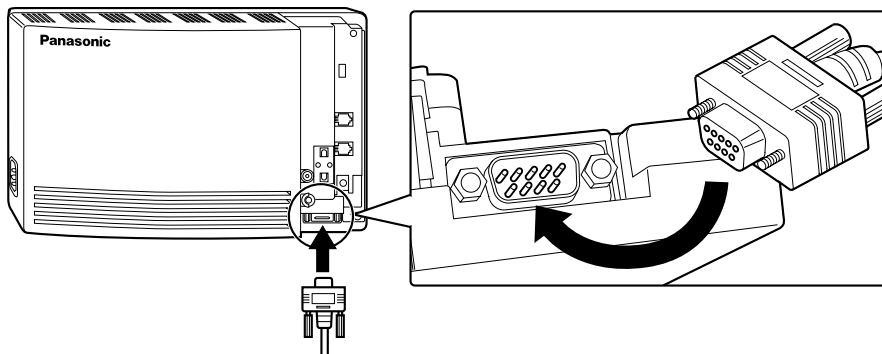

Insert the RS-232C cable into the VPS with the connector indicating the same direction.

The cable must be shielded and no longer than 2 m {6.5 feet}.

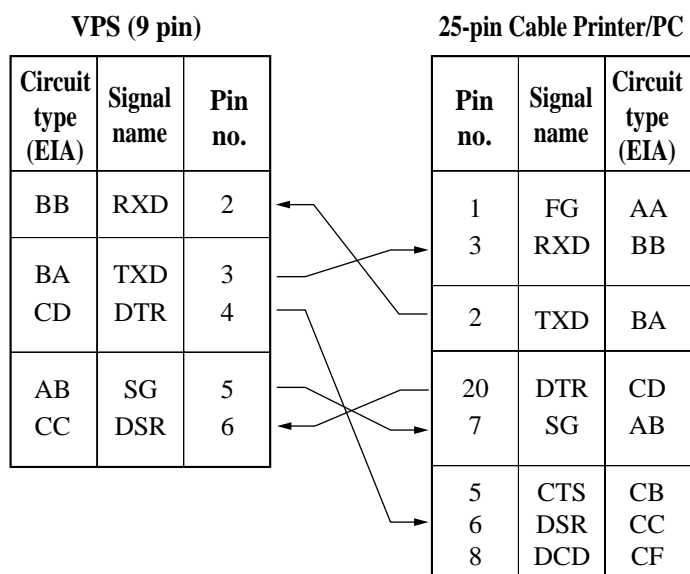
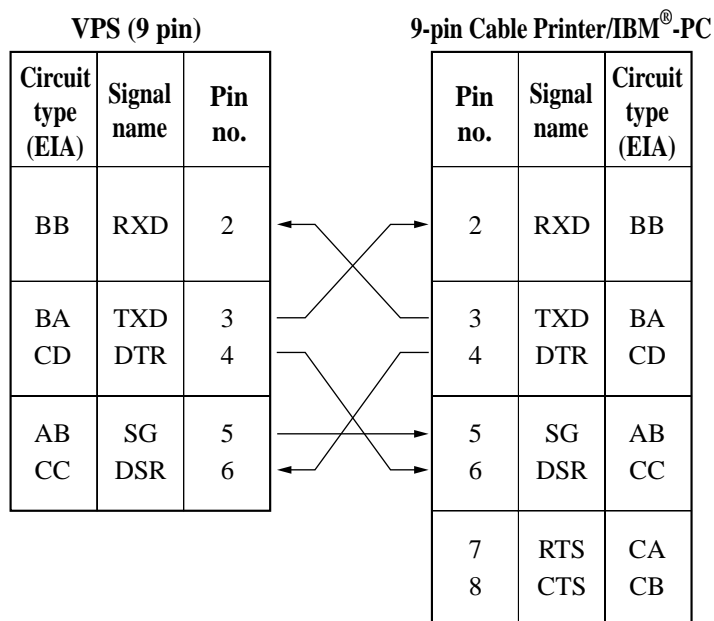

Table 7 Pin Configuration of the RS-232C

Pin Number	Signal Name		Circuit Type	
			RS-232C	CCITT
1	FG	Frame Ground	AA	101
2	TXD	Transmitted Data	BA	103
3	RXD	Received Data	BB	104
4	RTS	Request To Send	CA	105

Table 7 Pin Configuration of the RS-232C

Pin Number	Signal Name		Circuit Type	
			RS-232C	CCITT
6	DSR	Data Set Ready	CC	107
7	SG	Signal Ground	AB	102
8	DCD	Data Carrier Detect	CF	109
20	DTR	Data Terminal Ready	CD	108.2

2.8.3 RS-232C Signals

Frame Ground (FG)

Connects an external ground to the unit frame, usually the ground pin of the AC power cord.

Transmitted Data (TXD)—output

Conveys signals from the unit to the terminal/printer. A "mark" condition is held unless data or BREAK signals are being transmitted.

Received Data (RXD)—input

Conveys signals from the terminal/printer to the unit.

Request To Send (RTS)—output

This lead is held on whenever DSR is on.

Signal Ground (SG)

Connects to the DC ground of the unit for all interface signals.

Data Terminal Ready (DTR)—output

This signal line is turned on by the unit to indicate that it is RS-232C on-line. Circuit DTR ON does not indicate that communication has been established with the terminal/printer. It is switched off when the unit is RS-232C off-line.

Section 3

***INTEGRATING THE VPS WITH
PANASONIC KX-T PHONE SYSTEMS***

3.1 GUIDELINES FOR INTEGRATION

3.1.1 APT/DPT or Inband Signaling?

There are 3 types of integration available on the VPS: Inband Signaling, APT and DPT. The VPS used with any other brand of telephone equipment requires inband equipment.

KX-TA624 that can use APT Integration is:

- KX-TA624 Version Y581A or higher.

KX-TD series PBXs that can use DPT Integration are:

- KX-TD308 Version P871F or higher
- KX-TD816 Version P301O or higher
- KX-TD1232 Version P231U or higher

Likewise, the KX-TA1232 can also use DPT Integration:

- KX-TA1232 Version P831AA or higher (all versions)

Notes

- *To the VPS, the KX-TA1232 looks identical to the KX-TD1232.*
- *Depending on the model and/or the software version of the connected PBX, you may not be able to utilize some of the features available only with DPT Integration (see 4.1.1 Why Digital Integration is Important). For more information, call National Parts Center at 1-800-833-9626.*

3.1.2 Why Integration is Important

The VPS works well with most PBXs because its connections are made through a standard single-line (tip/ring) telephone interface. However, the VPS operation depends on the capabilities and features provided by the PBX; its performance will vary when connected with different PBX systems. For example, Follow-on (or Called Party) ID is a feature of the PBX. If the PBX does not have this feature, the VPS cannot transfer calls directly to the correct mailbox and play the Busy or No Answer greeting for that mailbox.

3.1.3 How the VPS and the PBX Communicate

To the PBX, the VPS looks like SLT sets. The PBX thinks that the VPS is an SLT, and the VPS mimics all actions a live attendant would carry out from an SLT.

For the VPS and the PBX to communicate, proper signaling is important. Like an attendant, the VPS places calls by going off-hook and dialing numbers. It starts call transfers with a hookswitch flash to put callers on hold and then dials the extension number. By recognizing call progress tones from the PBX, the VPS decides how calls should be handled. Inband Integration allows the PBX to send certain digits (touchtone) to the VPS, allowing it to recognize the status of the extension and take the appropriate action.

Table 8

VPS/PBX COMMUNICATION	
<u>PBX to VPS</u>	<u>VPS to PBX</u>
Call Progress Tones	SLT Signals
<ul style="list-style-type: none"> • ringback • busy • reorder 	<ul style="list-style-type: none"> • on/off hook • hookswitch flash • touchtones
Touchtones	

The VPS must also have access to certain PBX features. For example, if the VPS takes a message, one way it can notify the mailbox owner is by dialing the PBX's Message-Waiting-Lamp-On code. Once new messages are retrieved, the VPS dials the Message-Waiting-Lamp-Off code for that same mailbox owner.

3.1.4 PBX Requirements for Integration

The PBX must have certain capabilities and features to work with the VPS. (Although this section includes tests to help you evaluate the PBX, it may be necessary to refer to the PBX's documentation for detailed capability and feature descriptions.)

Single Line (Tip/Ring) Port Circuits

The VPS can only be connected to a PBX that supports SLT sets. Some PBXs need an OPX card to provide this connection. *However, some OPX cards do not provide all the capabilities listed in this section.*

Following are the minimum current and voltages that the PBX must supply:

Table 9

Minimum Loop Current	20 mA
Minimum Line Voltage	7 V DC
Minimum Ringing Voltage	40 V AC

Station to Station Touchtone Signaling

For system users to access VPS services and features, they must be able to send touchtones from their telephones to the VPS port. As a general rule, SLT sets can perform station-to-station touchtone signaling; however, many proprietary telephones cannot. Some PBXs need to be programmed to make proprietary sets use touchtone signaling.

If the PBX does not provide station-to-station touchtone signaling, VPS services and features will be limited.

TEST: Call an SLT extension from the telephone in question. When the call is answered, see if the person receiving the call hears touchtones when numbers are dialed.

Message Waiting Notification from an SLT

The PBX extensions should light a lamp or receive stutter dial tone when the Message-Waiting-Lamp-On code is dialed by the VPS. The VPS functions best when the extension number of the voice mailbox owner follows the Light-On or Light-Off code. On some PBXs, however, the extension number is dialed first, followed by a hookswitch flash and then the On code. This presents a problem if the extension is answered before the VPS sends the hook-switch flash.

If the PBX does not provide message waiting notification from an SLT, the VPS can only notify mailbox owners by dialing a beeper number or user-assigned extension.

This process slows down VPS performance as it dials the beeper or extension number and waits to confirm notification. The beeper or user-assigned extension notification is meant to be used for necessity, usually for mailbox owners who are often out of the office (e.g., sales people or field representatives). The only other option, without message waiting notification, is for mailbox owners to periodically call the VPS to check for messages.

TEST: See if dialing the On code from an SLT can turn on an extension's message waiting indicator.

Screened Transfer from an SLT

The PBX must provide a screened transfer from an SLT for the VPS to function properly.

A screened transfer:

- 1. Puts the caller on hold, usually with a hookswitch flash.*
- 2. Dials the extension.*
- 3. Checks to see if the called subscriber is in, out, or on another line, and whether or not that subscriber accepts the transfer.*
- 4. Completes the transfer (by going on-hook) or returns to the caller to say that the party is busy or not available. It then gives the caller an opportunity to leave a message.*

If the PBX does not provide screened transfer from an SLT, the VPS cannot give callers the option to leave a message in a subscriber's mailbox.

TEST: Place an outside call from an SLT. See if you can set up a screened transfer to another extension. Next, try the same test with an internal call. (The VPS may have to transfer both types of calls.)

Follow-on ID or Called Party ID

When forwarding or transferring a call to the VPS, a PBX with Follow-on ID sends the mailbox number of the called subscriber to the VPS before connecting the caller. The VPS responds by playing that subscriber's personal greeting. This operation is sometimes called Call Forward to Mailbox. Without this feature, the VPS cannot immediately play the greeting when the line is busy or there is no answer and allow the caller to leave a message.

3.2 PBX PARAMETERS AND PORT SETTINGS

3.2.1 General Guidelines and Definitions

Optimal performance of the VPS/PBX system relies on proper VPS programming. There are 3 categories of hardware settings: RS-232C, Port Settings, and PBX Interface Parameters. Entering a number sets some of the parameters, while others use sequence codes.

3.2.2 RS-232C Settings

- **Baud Rate (300-38400):** Specifies the speed at which the data is transferred in bits-per-second.
- **Word Bit Length (7-8):** Defines the number of bits in each byte or character.
- **Parity (N, O, E):** Specifies the parity used for error detection.
- **Stop Bit Length (1-2):** Specifies the number of bits used to signify the end of the byte.
- **Default:** 9600, 8, N, 1

3.2.3 Port Settings

There is no need to change these in a typical installation. Only change these parameters when connecting the VPS to a PBX other than a KX-T series PBX. Each port on the VPS should match the type of signaling the PBX expects. If you need to change these settings, refer to the PBX manual or customer support office to get the correct values for these settings.

- **Flash Time—100 ms, 300 ms, 600 ms, 900 ms:**
The minimum length of time that the PBX requires to recognize a hookswitch flash. Choose the amount that is equal to or greater than the PBX's setting.
- **CPC Signal (Calling Party Control Signal)—NONE, 6.5 ms, 150 ms, 300 ms, 450 ms, 600 ms:**
The length of time allowed for the short break in loop current that is used to indicate that the caller has hung up; usually set to NONE, since most PBXs do not provide this signal to single line ports. If choosing a setting other than NONE, use an amount equal to or less than the PBX or telephone company provided CPC signal.
- **Disconnect Time—1 s-8 s:**
The length of time that the line is temporarily unavailable after a call has ended.
- **Dial Mode—Touchtone, Pulse 10 pps, Pulse 20 pps:**
The type of signaling the PBX single line port expects to receive (pps = pulses per second).

3.2.4 PBX Interface Parameters

Dialing Parameters

- **PBX Type:**
Specifies the type of PBX which is connected to the VPS.
- **Integration Mode:**
Specifies the method of integration to be used between the VPS and PBX. If PBX type is set to the Panasonic KX-T series, the Inband Signaling parameters are set automatically and should not be altered. APT Integration is only available when a KX-TA624 PBX is connected and the software is upgraded. DPT Integration is only available when a KX-TD series or KX-TA1232 PBX is connected and the software is upgraded.

Table 10

SEQUENCE CODES	
D	Disconnect
F	Hookswitch Flash
R	Ring Detection
S	Silence Detection
T	Dial Tone Detection
W	Wait for 1 Second
X	Dial Extension
A:	Answer
0-9, *, #	Touchtone Digits

- **Operator Transfer Sequence:**
Tells the VPS how to transfer a call to the operator.
Example: FTX [hookswitch flash—dial tone—dial (operator) extn.]
- **Extension Transfer Sequence:**
Tells the VPS how to transfer a call to an extension.
Example: FTX [hookswitch flash—dial tone—dial extn.]
- **Alternate Extension (Transfer Sequence):**
Tells the VPS how to transfer a call to an extension that belongs to the "Alternate Extension Group". This is useful for extensions that need a special transfer procedure (i.e., blind transfer) such as modem extensions.
Example: FTXD [hookswitch flash—dial tone—dial extn.—hang up]
- **Reconnect Sequence on Busy:**
Tells the VPS how to return to the caller if the called extension is busy. PBXs differ in how they handle this function. Test from an SLT to determine the sequence.

- **Reconnect Sequence on No Answer:**
Tells the VPS how to return to the caller if the called extension does not answer. PBXs differ in how they handle this function. Test from an SLT to determine the sequence.
- **Reconnect Sequence on Refused Call:**
Tells the VPS how to return to the caller if the called extension's owner has enabled Call Screening to not take the call. PBXs differ in how they handle this function. Test from an SLT to determine the sequence.
- **Light On Sequence for Message Waiting Lamp:**
This is the dialing sequence that the VPS must use to turn on a message waiting lamp at an extension.
- **Light Off Sequence for Message Waiting Lamp:**
This is the dialing sequence that the VPS must use to turn off a message waiting lamp at an extension.
- **Call Waiting Sequence:**
This sequence is carried out by the VPS to perform call waiting when the called extension is busy. PBXs differ in how they handle this function. Test from an SLT to determine the sequence.
- **Release Sequence for Call Waiting:**
This sequence is carried out by the VPS to release call waiting. PBXs differ in how they handle this function. Test from an SLT to determine the sequence.

Inband Signaling

These parameters are used when the Integration Mode is set to Inband. If the PBX type is set to a KX-T series system, these parameters will be automatically set. If another type PBX is used, check that system's installation manual for settings.

Table 11

Code (default)	Call State	Sent to the Voice Mail Port When...
1	Ringback Tone	The extension dialed is ringing.
2	Busy Tone	The extension dialed is busy.
3	Reorder Tone	An invalid extension number is dialed or the call is inadvertently connected to another Voice Mail port (also heard when no touchtone receiver is available to the Voice Mail extension).
4	DND	The extension dialed has set DND feature (Do Not Disturb).
5	Answer	The extension dialed is answered.
6	Forwarded to Voice Mail (Ringing)	The extension dialed is forwarded to Voice Mail and another Voice Mail port is able to answer. (This lets the first Voice Mail port, usually an Auto Attendant, send the call to the other Voice Mail port.)

Table 11

Code (default)	Call State	Sent to the Voice Mail Port When...
7	Forwarded to Voice Mail (Busy)	The extension dialed is forwarded to Voice Mail and no other Voice Mail ports are available to accept the call. (This signals the Voice Mail port [usually Auto-Attendant] to let the caller to leave a message.)
8	Forwarded to Extn.	The extension dialed is forwarded to another non-Voice Mail extension.
9	Confirmation Tone	The Message Waiting Lamp On or Message Waiting Lamp Off code is dialed successfully.
#9	Disconnect	The caller disconnects. The central office must set a CPC signal to the PBX line for this signal to work for outside calls.

Digit Translation Table Parameters

These parameters allow PBXs that have a fixed Follow-on ID sequence to be used with the VPS. For example, a Follow-on ID sequence of [* * * 1001] can be changed to [#61001] by using these parameters.

- **Inter-Digit Time-Out:** *This parameter defines the interval of incoming signals (Follow-on ID) from the PBX to the VPS. The Digit Translation Table applies the digits received within this time to translation.*
- **Input-Output (up to 8 alphanumeric characters):** *When the system receives digits within the inter-digit time, it checks them against the input table. If they are found, the system utilizes the output digits in their place.*

The remainder of this section consists of step-by-step guides for software verification and programming of the recommended Panasonic PBX systems.

If you (the dealer) have any problem as you go through this section, please call 1-800-211-PANA(7262).

3.3 CONNECTING THE VPS WITH PANASONIC KX-T SERIES PBXs

3.3.1 VPS Programming for Inband Integration

Set parameters from the System Administration Terminal. The table below lists recommended parameters for Panasonic KX-T series PBXs.

Table 12

PBX Type	Other Manufacturers	T308/T616	T1232	T96	T336	TD816/ TD1232/ TA1232	TD308	TA series
Integration Mode	None	None	None	None	None	None	None	None
	Inband		Inband	Inband	Inband	Inband	Inband	Inband
Operator Transfer Sequence	FX (A)	FTX (A)	FTX (A)	FTX (A)	FTX (A)	FTX (A)	FTX (A)	FTX (A)
Extension Transfer Sequence	FX (A)	FTX (A)	FTX (A)	FTX (A)	FTX (A)	FTX (A)	FTX (A)	FTX (A)
Alternate Extension Transfer Sequence	FX (A)	FTX (A)	FTX (A)	FTX (A)	FTX (A)	FTX (A)	FTX (A)	FTX (A)
Reconnect Sequence on Busy	FWW	FWW	FWW	FWW	FWW	FWW	FWW	FWW
Reconnect Sequence on No Answer	FWW	FWW	FWW	FWW	FWW	FWW	FWW	FWW
Reconnect Sequence on Refuse Call	FWW	FWW	FWW	FWW	FWW	FWW	FWW	FWW
Light-On Sequence for Message Waiting Lamp	*	N/A	T701X#	T#91X	T*9X	T701X	T701X	T701X#
Light-Off Sequence for Message Waiting Lamp	*	N/A	T702X#	T#90X	T#9X	T700X	T700X	T702X#

Table 12

PBX Type	Other Manufacturers	T308/T616	T1232	T96	T336	TD816/ TD1232/ TA1232	TD308	TA series
Call Waiting Sequence	*	N/A	1	N/A	N/A	1	1	1
Release Sequence for Call Waiting	*	N/A	F	N/A	N/A	F	F	F

* Check with manufacturer.

N/A Not Available

(A) Adding "A" for "answer" to the operator and extension transfer eliminates the message: "You have a call" when the AA transfers a call. The VPS disconnects after line is answered. Adding "D" for "disconnect" creates a blind transfer.

3.3.2 KX-T123211D Software Verification and Programming for Inband Integration

1. Check the software version of the KX-T123211D by using System Program [98], which shows the software version number: **Y201Z940430(TM3)**

The underlined digits represent the software production date code (format YYMMDD). In this example, the date code is April 30, 1994 (year, month, day). For this software version, the software production date of the PBX must be April 30, 1994, or later.

If the software production date of the PBX is earlier than 4/30/94, call National Parts Center (1-800-833-9626) to order a software upgrade.

2. Enable System Program [80] for each extension connected to the VPS. This parameter is used to tell the KX-T123211D which extensions are connected to the VPS. Ports with this parameter enabled can receive Follow-on ID and DTMF call status signaling (busy, answered, disconnect, etc.) if the Voice Mail integration and DTMF integration features are also enabled.
3. Enable System Program [81] to turn on DTMF Integration. On extensions with the Voice Mail port parameter enabled, the KX-T123211D can send codes (touchtones) to indicate call states; this increases VPS efficiency. Codes apply to all transferred calls; outside calls only indicate disconnect (provided the KX-T123211D is programmed for CPC detection and the Central Office sends the CPC signal). Refer to the Table 10 in the Section 3.2.4 PBX Interface Parameters.

4. Put all extensions connected to the VPS into 1 extension group using System Program [60].

Reserve this extension group for these extensions! Do not mix other extensions into this group.

5. Enable hunting for the VPS extension group using System Program [08].
6. Set the hunting type for the VPS extension group to circular using System Program [09].
7. At every VPS extension, temporarily connect an SLT or butt set, go off-hook and **dial 7301#** to turn on Data Line Security. This prevents the KX-T123211D from sending Executive Override or Call Waiting tones to these extensions. We recommend that all Voice Mail port extensions have this feature enabled to avoid interruption of recording.
8. At every user's extension, go off-hook and **dial 7192#**. This sets the proper Follow-on ID sequences so that forwarded calls go directly to the extension's mailbox. The KX-T123211D automatically sends the extension's digits to the Voice Mail port before connecting the caller.

For Follow-on ID to work:

- *Ports connected to the VPS must be assigned as Voice Mail ports.*
- *Extensions must be forwarded to the first port of the Voice Mail (using the Busy/No Answer mode or the All Calls mode).*
- *The mailbox number should be the same as the extension number.*

Interaction with other features:

- **Call Forwarding**—*If the extension is forwarded to an extension that is also forwarded, the forwarding will not work.*
- **Call Hunting**—*Hunting does not interfere with Follow-on ID.*
- **Call Transfer**—*Calls transferred to an extension with Follow-on ID and call forwarding enabled will be forwarded directly to the mailbox.*
- **Data Line Security**—*We recommend that all Voice Mail port extensions have this feature enabled to avoid interruption of recording by Executive Override tone or Call Waiting tone.*

9. Select the appropriate outside (CO) Line feature settings depending on how your customer plans to use the VPS: A) to answer all incoming calls, B) as an operator backup, or C) to only answer calls not answered by user extensions.

Recommended outside (CO) line feature settings:

- a) If the VPS is answering all incoming calls:

Outside (CO) Line Mode—Use System Programs [51] and [52] to set this parameter. Program all lines DIL to the first extension of the Voice Mail hunt group. The KX-T123211D will allow incoming CO calls to hunt only if the outside (CO) lines are DIL to the first port of the hunt group. Lines programed as "Normal" do not hunt.

b) If the VPS is only answering calls not answered by the operator (Operator Backup):

Flexible Ringing Assignment—For each outside (CO) line, use System Programs [47] (Day Mode) and [48] (Night Mode) to enable ringing at the operator's extension (jack).

Delayed Ringing Assignment—To give the operator time to answer the call before the VPS picks up, we recommend setting the delay to 3 or 4 rings for each extension connected to the VPS. Use System Programs [49] (Day Mode) and [50] (Night Mode).

Outside (CO) Line Mode—Set the mode for each outside (CO) line to "Normal". Use System Programs [51] and [52] to set this parameter.

c) If the VPS is only answering calls not answered by user extensions:

Flexible Ringing Assignment—For each outside (CO) line, use System Programs [47] (Day Mode) and [48] (Night Mode) to enable ringing on every extension (jack) that you want to have ring.

Delayed Ringing Assignment—To give users time to answer the call before the VPS picks up, we recommend setting the delay to 3 or 4 rings for each extension connected to the VPS. Use System Programs [49] (Day Mode) and [50] (Night Mode).

CO Mode—Set the mode for each outside (CO) line to "Normal". Use System Programs [51] and [52] to set this parameter.

3.3.3 KX-TA Series Programming for Inband Integration via the Manager's Extension

Note

If your PBX is the KX-TA1232, please refer to the procedure described in 3.3.4 KX-TD816, KX-TD1232, KX-TA1232 and KX-TD308 Programming for Inband Integration via the Manager's Extension or 3.3.5 KX-TD816, KX-TD1232, and KX-TA1232 Programming for Inband Integration via the Operating and Maintenance Tool for programming.

1. Enable System Program [102] for each extension connected to the VPS. Jack 07, or jacks 07 and 08 can be assigned for the VPS1 as the Voice Mail port. Jack 15, or jacks 15 and 16 can be assigned for the VPS2.

This parameter is used to tell the KX-TA series which extensions are connected to the VPS. Ports with this parameter enabled can receive Follow-on ID and touchtone call status Signaling (busy, answered, disconnect, etc.) if the Voice Mail integration and Touchtone Integration features are also enabled.

2. Enable System Program [103] to turn on Touchtone Integration. On extensions with the Voice Mail port parameter enabled, the KX-TA series can send codes (touchtones) to indicate call states; this increases VPS efficiency. Codes apply to all transferred calls; outside calls only indicate disconnect (provided the KX-TA series is programmed for CPC Detection, and the Central Office sends the CPC signal). Refer to the Table 10 in Section 3.2.4 PBX Interface Parameters.

3. Put all extensions connected to the VPS into 1 extension group using System Program [600].

Reserve this extension group for these extensions! Do not mix other extensions into this group.

Note

Up to two VPS units can be connected to the KX-TA624. When two VPS units are connected to the KX-TA624, 2 different extension groups should be assigned for each VPS in System Program [600]. One extension group is for jack 07, or jacks 07 and 08 of the KX-TA624. The other extension group is for jack 15, or jacks 15 and 16.

4. Enable hunting for the VPS extension groups using System Program [100].
5. Set the hunting type for the VPS extension groups to circular using System Program [101].
6. At every VPS extension, temporarily connect an SLT or butt set, go off-hook and dial 7301# to turn on Data Line Security. This prevents the KX-TA series from sending Executive Override or Call Waiting tones to these extensions. We recommend that all Voice Mail port extensions have this feature enabled to avoid interruption of recording.
7. Select the appropriate outside (CO) line feature settings depending on how your customer plans to use the VPS: A) to answer all incoming calls, B) as an operator backup, or C) to only answer calls not answered by user extensions.

Recommended outside (CO) line feature settings:

- a) If the VPS is answering all incoming calls:

Outside (CO) Line Mode—Use System Programs [414] (Day Mode), [415] (Night Mode), [416] (Lunch Mode) to set this parameter. Program all lines DIL to the first extension of the Voice Mail hunt group. The KX-TA series will allow incoming outside calls to hunt only if the outside (CO) lines are DIL to the first port of the hunt group. Lines programmed as "Normal" do not hunt.

- b) If the VPS is only answering calls not answered by the operator (Operator Backup):

Flexible Ringing Assignment—For each outside (CO) line, use System Programs [408] (Day Mode), [409] (Night Mode) and [410] (Lunch Mode) to enable ringing at the operator's extension (jack).

Delayed Ringing Assignment—To give the operator time to answer the call before the VPS picks up, we recommend setting the delay to a few seconds for each extension connected to the VPS. Use System Programs [411] (Day Mode), [412] (Night Mode) and [413] (Lunch Mode).

Outside (CO) Line Mode—Set the mode for each outside (CO) line to "Normal". Use System Programs [414] (Day Mode), [415] (Night Mode) and [416] (Lunch Mode) to set this parameter.

- c) If the VPS is only answering calls not answered by user extensions:

Flexible Ringing Assignment—For each outside (CO) line, use System Programs [408] (Day Mode), [409] (Night Mode) and [410] (Lunch Mode) to enable ringing on every extension (jack) that you want to have ring.

Delayed Ringing Assignment—To give users time to answer the call before the VPS picks up, we recommend setting the delay to a few seconds for each extension connected to the VPS. Use System Programs [411] (Day Mode), [412] (Night Mode) and [413] (Lunch Mode).

Outside (CO) Line Mode—Set the mode for each outside (CO) line to "Normal". Use System Programs [414] (Day Mode), [415] (Night Mode) and [416] (Lunch Mode) to set this parameter.

CAUTION

DO NOT create a mailbox in both VPS for the same extension. Each extension can have a maximum of 1 mailbox in either VPS. The extension should assign a Voice Mail extension from the VPS which contains its mailbox as the destination for Call Forwarding and Voice Mail Transfer. DO NOT assign a Voice Mail extension from the other VPS. For example, if jack 06 (extension 106) has its mailbox in the VPS1, assign extension 107 or 108 as the destination, not extension 115 or 116 (see the following diagram).

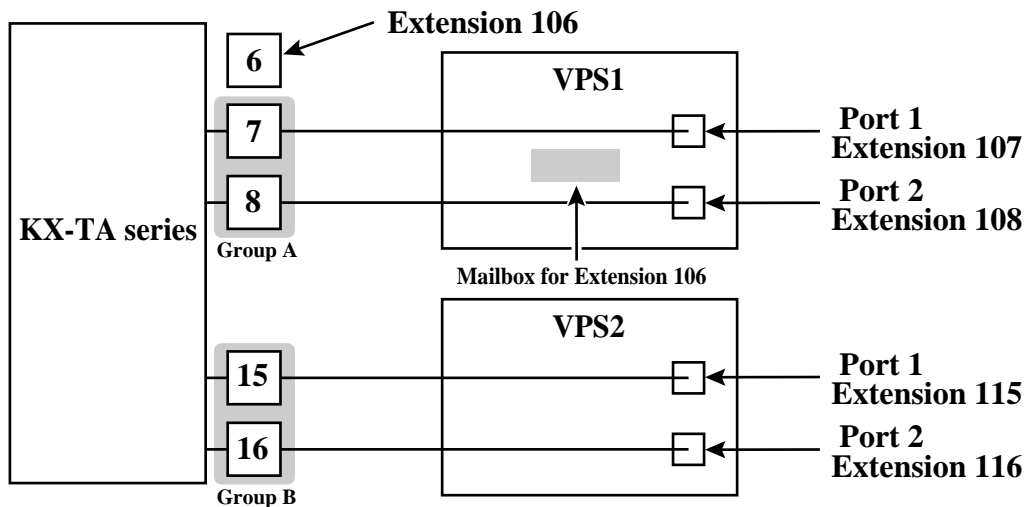

3.3.4 KX-TD816, KX-TD1232, KX-TA1232 and KX-TD308 Programming for Inband Integration via the Manager's Extension

Select a maximum of 2 station ports to be connected to the VPS. Plug each station into a Voice Mail port.

Go into System Program [602] and assign the Voice Mail stations to a different extension group. By default, all stations are in Extension Group 1.

Go into System Program [106] and assign the new Extension Group to Auto Attendant (AA).

3.3.5 KX-TD816, KX-TD1232, and KX-TA1232 Programming for Inband Integration via the Operating and Maintenance Tool

1. Go to the *Main Menu*. Choose "System Data Programming".

(*BATCH* [1] or *INTERACTIVE* [2]).

- *Before choosing Batch Programming, you must open a file in the Disk File Management Menu (Item 3).*
- *Before choosing Interactive Programming, you must connect with the system in the DSHS Connect/Disconnect menu.*

Main Menu

1. System Data Programming (BATCH)
2. System Data Programming (INTERACTIVE)
3. Disk File Management
4. DSHS Management
5. DSHS Connect/Disconnect
6. Quit

Select the number : []

2. Choose "Station" from the *System Data Programming Main Menu*.

System Data Programming Main Menu

1. Line
- 2. Station**
3. System
4. Toll Restriction
5. ARS
6. Aux. Ports
7. Additional Function
8. Caller ID

Select the number: [2]

3. Choose "Station Setting" from the *Station Menu*.

Station Menu

1. Station Setting

- 2. COS & Mailbox ID
- 3. CO line Outgoing
- 4. DIL 1:N
- 5. ISDN Extension Setting
- 6. SDN Extension CO outgoing
- 7. Flexible CO Keys
- 8. Flexible PF Keys
- 9. DSS
- 10. Lunch/Break Group
- 11. FWD/DND Setting
- 12. FWD/DND Setting (OPX)

Select the number: [**1**]

4. Enable XDP ports. Place Voice Mail extensions in Extension Group 8.

Station Setting

Jack	EXT	Name	X D P	E X G	Doorphone		LCS Mode	FWD N/A Time	Cordless PITS
					Day 1 2 3 4	Night 1 2 3 4			
01-1	[101]	[]N	[1]	Y Y Y Y	Y Y Y Y	Stop Rec	[00]	N
01-2	[201]	[] -	[1]	N N N N	N N N N		[00]	-
02-1	[102]	[]N	[1]	N N N N	N N N N	Stop Rec	[00]	N
02-2	[202]	[] -	[1]	N N N N	N N N N		[00]	-
03-1	[103]	[]N	[1]	N N N N	N N N N	Stop Rec	[00]	N
03-2	[203]	[] -	[1]	N N N N	N N N N		[00]	-
04-1	[104]	[]N	[1]	N N N N	N N N N	Stop Rec	[00]	N
04-2	[204]	[] -	[1]	N N N N	N N N N		[00]	-
05-1	[105]	[] <u>Y</u>	[1]	N N N N	N N N N	Stop Rec	[00]	N
05-2	[205]	[] -	[8]	N N N N	N N N N		[00]	-
06-1	[106]	[] <u>Y</u>	[1]	N N N N	N N N N	Stop Rec	[00]	N
06-2	[206]	[] -	[8]	N N N N	N N N N		[00]	-
07-1	[107]	[]N	[1]	N N N N	N N N N	Stop Rec	[00]	N
07-2	[207]	[] -	[1]	N N N N	N N N N		[00]	-
08-1	[108]	[]N	[1]	N N N N	N N N N	Stop Rec	[00]	N
08-2	[208]	[] -	[1]	N N N N	N N N N		[00]	-

5. Return to the *System Data Programming Main Menu*. Select "System".

6. Choose "Miscellaneous" from the System Menu.

System Menu

- | | |
|----------------------------|-----------------------------|
| 01. Day/Night | 14. Opera/Manager/EXT Group |
| 02. Class of Service | 15. Miscellaneous |
| 03. Emergency/Quick Dial | 16. Caller ID Modification |
| 04. Speed Dial | 17. Switch Type |
| 05. Absent Message | 18. DID |
| 06. Flexible Numbering | 19. Lunch/Break Time |
| 07. Account Code | 20. System Time |
| 08. Special Carrier | 21. Version |
| 09. Timer | 22. ISDN Card |
| 10. Voice Mail | 23. T1 Card |
| 11. Voice Mail Integration | 24. T1 Minor Error |
| 12. UCD | |
| 13. Phantom | |

Select the number: **[15]**

7. Choose the "Call Hunting" extension group. Set the last extension group to [A] for Automated Attendant.

Miscellaneous

Expansion Card Type (Master) =>	EXP1	EXP2	EXP3					
(Slave) =>	COT	EXT1	EXT2					
	COT	EXT1	EXT2					
Local Access => Priority =	1	2	3	4	5	6	7	8
TRG No. =	[1]	[2]	[3]	[4]	[5]	[6]	[7]	[8]
Call Hunting => EXG No. =	1	2	3	4	5	6	7	8
	D	D	D	D	D	D	D	<u>A</u>
SPD TRS Override =>	Disable							
CO Auto-Hold by Push DSS-Key =>	Enable							
CO-Key =>	Disable							
Adjust Time =>	[01:00] AM							
PBX Code =>	[]							
				Caller ID Extension				
				EXP 1	Not Stored			
				EXP 2	Not Stored			
				EXP 3	Not Stored			
				EXP 4	Not Stored			

8. Return to the *System Data Programming Main Menu*. Select "Line" and then select "CO Line Setting 1". Program all lines DIL to the first extension of the Voice Mail hunt group.

CO Line Setting

CO No	C O N	T R G	D I A L	D T M F	P S	C I D	CPC		DIL 1:1		R E V	DIL 1:1	
							Detection Mode	Out	EXT No Day	EXT No Night		Lunch Group	Break Group
01	Y	[1]	D	80	10	N	Disable	Disable	<u>EXT[205]</u>	<u>EXT[205]</u>	Reg.	[]	[]
02	Y	[2]	D	80	10	N	Disable	Disable	<u>EXT[205]</u>	<u>EXT[205]</u>	Reg.	[]	[]
03	Y	[3]	D	80	10	N	Disable	Disable	<u>EXT[205]</u>	<u>EXT[205]</u>	Reg.	[]	[]
04	Y	[4]	D	80	10	N	Disable	Disable	<u>EXT[205]</u>	<u>EXT[205]</u>	Reg.	[]	[]
05	Y	[5]	D	80	10	N	Disable	Disable	<u>EXT[205]</u>	<u>EXT[205]</u>	Reg.	[]	[]
06	Y	[6]	D	80	10	N	Disable	Disable	<u>EXT[205]</u>	<u>EXT[205]</u>	Reg.	[]	[]
07	Y	[7]	D	80	10	N	Disable	Disable	<u>EXT[205]</u>	<u>EXT[205]</u>	Reg.	[]	[]
08	Y	[8]	D	80	10	N	Disable	Disable	<u>EXT[205]</u>	<u>EXT[205]</u>	Reg.	[]	[]
09	Y	[8]	D	80	10	N	Disable	Disable	<u>EXT[205]</u>	<u>EXT[205]</u>	Reg.	[]	[]
10	Y	[8]	D	80	10	N	Disable	Disable	<u>EXT[205]</u>	<u>EXT[205]</u>	Reg.	[]	[]
11	Y	[8]	D	80	10	N	Disable	Disable	<u>EXT[205]</u>	<u>EXT[205]</u>	Reg.	[]	[]
12	Y	[8]	D	80	10	N	Disable	Disable	<u>EXT[205]</u>	<u>EXT[205]</u>	Reg.	[]	[]

3.3.6 KX-TD308 Programming for Inband Integration via the Operating and Maintenance Tool

1. Go to the *Main Menu*. Choose "System Data Programming".
(BATCH [1] or INTERACTIVE [2])

- Before choosing Batch Programming, you must open a file in the Disk File Management Menu (Item 3).
- Before choosing Interactive Programming, you must connect with the system in the DSHS Connect/Disconnect menu.

Main Menu

1. System Date Programming (BATCH)
 2. System Date Programming (INTERACTIVE)
 3. Disk File Management
 4. DSHS Management
 5. DSHS Connect/Disconnect
 6. Quit
- Select menu Number:[]

2. Choose "Station (ALT-S)" from the *System Data Programming Main Menu*.

System Data Programming Main Menu

- AuxPorts (ALT-U)
- Manager (ALT-M)
- System (ALT-Y)
- CO-Line (ALT-L)
- Station (ALT-S)**
- TRS (ALT-T)
- ARS (ALT-A)

3. Choose "Settings (1)" in the *Sub Menu*.

Sub Menu

<u>Settings (1)</u>	<u>1</u>
Settings (2)	2
CO Line (O)utgoing	O
(D)il Line 1:N	D
Flex (C)o Keys :1-24	C
Flex (P) F Buttons :1-12	P

4. Choose which single line extensions will be attached to Voice Mail.
If using XDP ports, enable "XDP" for the connect jacks.
Place Voice Mail extensions in Extension Group "8".

Station Setting 1

Jack	Ext.	Name	XDP	EXG	DoorPhone		LCS Mode	
					Day	Night		
1-1	[11]]	[[N]	[1]	[Y]	[Y]	[STOP REC]
1-2	[21]]	[[1]	[N]	[N]	
2-1	[12]]	[[N]	[1]	[N]	[N]	[STOP REC]
2-2	[22]]	[[1]	[N]	[N]	
3-1	[13]]	[[N]	[1]	[N]	[N]	[STOP REC]
3-2	[23]]	[[1]	[N]	[N]	
4-1	[14]]	[[N]	[1]	[N]	[N]	[STOP REC]
4-2	[24]]	[[1]	[N]	[N]	
5-1	[15]]	[[Y]	[1]	[N]	[N]	[STOP REC]
5-2	[25]]	[[8]	[N]	[N]	
6-1	[16]]	[[N]	[1]	[N]	[N]	[STOP REC]
6-2	[26]]	[[1]	[N]	[N]	
7-1	[17]]	[[N]	[1]	[N]	[N]	[STOP REC]
7-2	[27]]	[[1]	[N]	[N]	
8-1	[18]]	[[N]	[1]	[N]	[N]	[STOP REC]
8-2	[28]]	[[1]	[N]	[N]	

5. Select "SAVE(F7)". Return to the *System Data Programming Main Menu*. Select "System".

6. Choose "System (ALT-Y)" from the *System Data Programming Main Menu*.

System Data Programming Main Menu

- Auxports (ALT-U)
- Manager (ALT-M)
- System (ALT-Y)**
- CO-Line (ALT-L)
- Station (ALT-S)
- TRS (ALT-T)
- ARS (ALT-A)

7. Choose "Miscellaneous" from the System Menu.

System Menu

(A)ccount Codes	A
Caller (I)D	I
Class of Se(R)vice	R
(D)ay/Night	D
(E)mergency/Quick Dial	E
(F)loating Extensions	F
Fle(X)ible Numbers	X
(M)iscellaneous	M
P(H)antom Extensions	H
Seria(L) Interface	L
S(P)ecial Carrier	P
(T)imers	T
Add. F(U)ctions - SYSTEM	U
Add. Functions - (C)OS	C
(V)M Status/Command DTMF Set	V
Voice Mail Inte(G)ration	G

8. Choose the "Call Hunting" extension group. Set the last extension group to "[AA]" for Automated Attendant.

Miscellaneous

Automatic Access => Priority	=> 1 2 3
CO No.	=> [1] [2] [3]
Call Hunting => EXG No.	=> 1 2 3 4 5 6 7 8
	[DIS] [DIS] [DIS] [DIS] [DIS] [DIS] [DIS] <u>[AA]</u>
Automatic Hold By CO Button	=> [Disable]
Automatic Hold By DSS Button	=> [Enable]
SPD TRS Override	=> [Disable]
FAX Transfer Extension	=> []
Caller ID Extension	=> []
Caller ID Modification	
Area Code	=> []
Local Call Del,Add	=> [3] []
Long Distance Call Del,Add	=> [0] [1]

9. Select "SAVE(F7)". Return to the System Data Programming Menu.

10. Choose "CO-Line (ALT-L)" from the *System Data Programming Main Menu*.

System Data Programming Main Menu

- AuxPorts (ALT-U)
- Manager (ALT-M)
- System (ALT-Y)
- CO-Line (ALT-L)**
- Station (ALT-S)
- TRS(ALT-T)
- ARS(ALT-A)

11. Choose "Settings (2)" in the *Sub Menu*, and program all lines DIL to the first extension of the Voice Mail hunt group.

Sub Menu

- Settings (1) 1
- Settings (2) 2**
- (I)ntercept/Timers/PBX Access Code I

CO Line Setting

CO	CPC		DIL 1:1	
	Signal Detection Incoming	Signal Detection Outgoing	EXT DAY	EXT NIGHT
1	[400 ms]	[Disable]	[25]	[25]
2	[400 ms]	[Disable]	[25]	[25]
3	[400 ms]	[Disable]	[25]	[25]

Section 4

***INTEGRATING THE VPS WITH THE
PANASONIC KX-TA SERIES PBX AND KX-
TD SERIES PBX***

4.1 GUIDELINES FOR DIGITAL INTEGRATION

4.1.1 Why Digital Integration is Important

The VPS works well with most PBXs because its connections are made through a standard single line (tip/ring) telephone interface. However, the communication between the PBX and VPS is best when Digital Integration is used; the VPS is already set up to communicate through Digital Integration.

Once Digital Integration is established, the PBX sends information to the VPS through the data link. This information enables the VPS to identify the extension that is calling, know where from and why a call is forwarded, and recognize what the caller wants to do. This communication allows features that are only available with Digital Integration—several of which are described below:

Table 13

DIGITAL INTEGRATION FEATURES	
Remote Call Forwarding Set (DPT Integration only)	The subscribers and the Message Manager can program their extensions from a remote location to forward various types of calls to a desired extension or an outside telephone.
Auto Configuration	The VPS knows what extension numbers exist on the PBX and creates mailboxes for each extension automatically. Also sets the VPS clock with data from the PBX clock.
Live Call Screening	Extension users can monitor messages as they are being left in the mailbox or intercept if required.
Two-Way Recording	Extension users can record conversations into their own mailboxes by pressing one button.
Two-Way Transfer	Extension users can record conversations into another person's mailbox by pressing a button and dialing an extension number.
Direct Mailbox Access	The subscriber can directly enter his mailbox when he calls the VPS. He does not have to dial his mailbox number.
Trunk Service (Universal Port)	Each PBX trunk (CO line) group can be assigned one of 4 incoming call services: Voice Mail Service, Automated Attendant Service, Interview Service and Custom Service.

Table 13

DIGITAL INTEGRATION FEATURES	
Intercom Paging*	Callers can page subscribers through built-in speakers and external paging equipment. For a Caller ID Caller, if his name has been recorded for the Caller Name Announcement feature, the name will be announced at the end of the page.
Caller Name Announcement (System/Personal)*	The VPS announces the prerecorded Caller ID callers' names when: (1) extension users listen to messages from assigned numbers left in their mailboxes, (2) the VPS transfers calls from assigned numbers to the users, and (3) the VPS pages the users by intercom. If the same Caller ID number is programmed for both system and personal caller name announcements, the VPS will use the personal caller name.
Caller ID Call Routing*	The VPS automatically sends calls from pre-assigned Caller ID numbers to the desired extension, mailbox or Custom Service.
Personal Greeting for Caller ID*	Each subscriber can record up to 4 personal greeting messages for special callers.
Time Synchronization (DPT Integration only)	Whenever the PBX sets a new date and time or when DPT Integration is established, the data is automatically registered in the VPS.

- * **Caller ID Note 1:** When an incoming outside call reaches the VPS via the PBX, the VPS will wait about 2 rings before answering the call to receive the Caller ID information properly from the PBX. This waiting time can be changed by using the WCID command (see 7.2.20 Wait for Caller ID (WCID) in 7.2 UTILITY COMMANDS).
- Caller ID Note 2:** In the documentation for the KX-TD816/1232 series PBX, the Caller ID feature is called CLIP (Calling Line Identification Presentation).

Note

Depending on the model and/or the software version of the connected PBX (see 3.1.1 APT/DPT or Inband Signaling?), you may not be able to utilize some of the features listed above. For more information, call National Parts Center at 1-800-833-9626.

4.2 CONNECTING THE VPS WITH THE PANASONIC KX-TA624

4.2.1 KX-TA624 Software Verification and Programming for Digital Integration via the Manager's Extension

It is important that the KX-TA624 has the proper software level to allow Digital Integration with the VPS. Follow the procedures below to confirm the software level, then complete the required programming before starting up the VPS.

All of the following procedures must be done after entering system programming. Refer to the KX-TA624 Installation Manual for instructions on how to enter the system programming mode.

Software Verification

1. Check the software version of the KX-TA624 using System Program [998].

Example: Y581AYYMMDD(M)

The underlined digits represent the software production date code (year, month, day). For Digital Integration, the software version of the PBX must be Y581A or higher.

If the software version of the PBX is lower than this, call National Parts Center (1-800-833-9626) to order a software upgrade.

From the SYS-PGM NO ? screen:

- a) Enter [998].
- b) Press the NEXT button (SP-PHONE). The system displays the ROM version and the date it was created.

This version must be Y581A or higher for Digital Integration to be utilized.

2. Set the date and time using System Program [000].
Date and time are automatically synchronized between the VPS and the Panasonic KX-TA624 during Auto Configuration or Quick Setup.
3. Set PBX extension numbering using System Program [009].
4. Assign the **Voice Mail Port**. This program tells the PBX which jacks will be connected to the VPS. This allows the PBX to send the proper Digital Integration information to those ports. Jack 07, or jacks 07 and 08 can be assigned for the VPS1 as the Voice Mail Port. Jack 15, or jacks 15 and 16 can be assigned for the VPS2.
 - *KX-TVS50 (2 ports): assign max. 2 jacks*

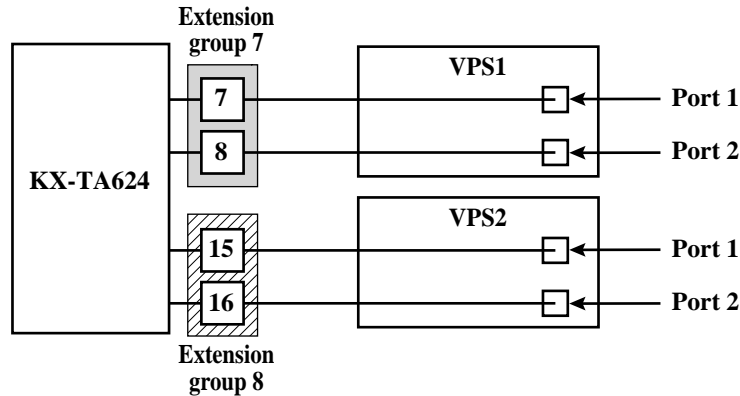

From the **SYS-PGM NO ?** screen:

- a) Enter **[130]** (for VPS1) or **[131]** (for VPS2).
- b) Press the **NEXT** button (SP-PHONE).
Screen output: *Disable*
- c) Press the **SELECT** button (AUTO-ANSWER).
Screen output: *Port 7 or Port 15*
- d) To assign 2 jacks, Press the **SELECT** button (AUTO-ANSWER) again.
Screen output: *Port 7 & 8 or Port 15 & 16*
To assign 1 jack, skip this step.
- e) Press **STORE**.
- f) Press **END** (HOLD).

Conditions: *The lowest jack (jack 07 or jack 15) entered here must be connected to the Port 1 of the VPS.*

To change the current assignment from "Port 7" to "Port 7 & 8", you must first change it to "Disable". Likewise, if you want to change it from "Port 7 & 8" to "Port 7", you must first change it to "Disable". If the current assignment is already "Disable", you can make a change in 1 step. This condition also applies to System Program [131].

When "Port 7 & 8" is selected in program [130], extension jack numbers 07 and 08 will be in extension group 7 automatically. Likewise, when "Port 15 & 16" is selected in program [131], extension jack numbers 15 and 16 will be in extension group 8 automatically. Also the Station Hunting type is set as "Circular" automatically in each of these 2 extension groups.

5. Select the appropriate outside (CO) Line feature settings depending on how your customer plans to use the VPS: A) to answer all incoming calls, B) as an operator backup, or C) to only answer calls not answered by user extensions.

Recommended Outside (CO) Line feature settings:

- a) If the VPS is answering all incoming calls:
 - Outside (CO) Line Mode**—Use System Programs [414] (Day Mode), [415] (Night Mode), [416] (Lunch Mode) to set this parameter. Program all lines DIL to the first extension of the Voice Mail hunt group. The KX-TA624 will allow incoming outside calls to hunt only if the outside (CO) lines are DIL to the first port of the hunt group. Lines programmed as "Normal" do not hunt.
- b) If the VPS is only answering calls not answered by the operator (Operator Backup):
 - Flexible Ringing Assignment**—For each outside (CO) line, use System Programs [408] (Day mode), [409] (Night Mode) and [410] (Lunch Mode) to enable ringing at the operator's extension (jack).
 - Delayed Ringing Assignment**—To give the operator time to answer the call before the VPS picks up, we recommend setting the delay to 3 or 4 rings for each extension connected to the VPS. Use System Programs [411] (Day Mode), [412] (Night Mode) and [413] (Lunch Mode).
 - Outside (CO) Line Mode**—Set the mode for each outside (CO) line to "Normal". Use System Programs [414] (Day Mode), [415] (Night Mode) and [416] (Lunch Mode) to set this parameter.

Table 14 2 CO (Outside) Lines, 2 Ports

CO Lines	Ports
1	1, 2
2	1, 2

- c) If the VPS is only answering calls not answered by user extensions:
 - Flexible Ringing Assignment**—For each outside (CO) line, use System Programs [408] (Day Mode), [409] (Night Mode) and [410] (Lunch Mode) to enable ringing on every extension (jack) that you want to have ring.
 - Delayed Ringing Assignment**—To give users time to answer the call before the VPS picks up, we recommend setting the delay to 3 or 4 rings for each extension connected to the VPS. Use System Programs [411] (Day Mode), [412] (Night Mode) and [413] (Lunch Mode).
 - Outside (CO) Line Mode**—Set the mode for each outside (CO) line to "Normal". Use System Programs [414] (Day Mode), [415] (Night Mode) and [416] (Lunch Mode) to set this parameter.

6. **Connect** the **jack(s)** assigned in Step 3 to the VPS.
7. **Connect** your **personal computer** to the VPS and start your communication software (i.e., HyperTerminal, Procomm Plus, Smartcom...).
8. **Disconnect** the power from the VPS and **set** the **DIP Switch** to **position 5**.

Only perform this step when initially setting up the system.

CAUTION

Setting the DIP Switch to position 5 will default the Voice Processing System, resulting in a loss of all user programming, and voice messages (except User1 and User2 prompts).

- 9. Plug in and power up** the VPS and wait approximately 2.5 min while the system initializes.

Before starting the VPS, make sure all installation and line connections have been done as described in Section 2 INSTALLATION.

After turning the power on, the system starts up in the following sequence:

- *The Power Indicator light goes on.*
- *The Power Indicator light begins to flash.*
- *"Checking Flash Memory Cards." is displayed on the screen.*

Screen output:

Checking Flash Memory Cards.
Please wait...
PORT TEST...
SYSTEM SETUP
1... 2... 3...

- *The VPS tests the CPU card, the flash memory, and the ports until "1...2...3..." is displayed.*
- *Active ports are displayed on the screen.*

Screen output:

Active COs: 1 2
APT Interface Connection is Established
**** ON LINE MODE ****

The display will alert you if System Setup is not completed successfully.

Screen output:

Active COs: 1 2
APT Interface Connection is not Established
**** OFF LINE MODE ****

This message is shown when the digital (APT) connection between the VPS and telephone system cannot be established.

Possible causes of the message: "APT Interface Connection is not Established"

Table 15

Cause	Action
The PBX is not a correct type. Since the VPS is configured to communicate with the default PBX type (the KX-TA series under APT Integration), this message will always appear when connecting to another type of PBX.	Connect a correct PBX and set the PBX type by using Quick Setup (see Section 5 CUSTOMIZING THE SYSTEM).
The cabling between the PBX extension ports and the VPS is not 4-wire or is improperly connected.	Confirm the cabling is connected as described in Section 2 INSTALLATION.
The PBX is a correct type but does not have the proper software level to support APT/DPT Integration.	Contact National Parts Center at 1-800-833-9626 or use Inband Integration under hardware settings.
The PBX is not programmed properly to support APT/DPT Integration.	Do required integration programming as described in this chapter.

10. Start up completed.

- a) The Power Indicator light stops blinking when the start-up has been successful. (The delay varies according to the system's condition.)
- b) ****ON LINE MODE**** is displayed.
- c) System prompt [**>**] is displayed on the screen. To enter system administration, **Press ENTER**. All parameters can be set through the menu-driven program.

11. Go to the *System Administration Top Menu*. Type [**5**] and **Press ENTER**, or Type [**3**] then **QSET** and **Press ENTER** for Quick Setup and follow the Auto Configuration Instructions.

CAUTION

When 2 VPSs are connected to the KX-TA624, the following 2 procedures should be done to make the VPSs work correctly.

1. *Delete a mailbox in either VPS so that each extension has only ONE MAILBOX. After Auto Configuration has been executed, an extension has a mailbox in both VPS1 and VPS2. However each extension can have a maximum of 1 mailbox in either VPS. To delete a mailbox, Type [D] (Delete) in the "Make (Make/Delete)" field (see "Step 4 Creating Mailboxes" in 5.1.3 Starting the Quick Setup). The extension should assign a Voice Mail extension from the VPS which contains its mailbox as the destination for Call Forwarding and Voice Mail Transfer. DO NOT assign a Voice Mail extension from the other VPS. For example, if jack 06*

(extension 106) has its mailbox in the VPS1, assign extension 107 or 108 as the destination, not extension 115 or 116 (see diagram below).

2. Change the extension numbers of both VPS port 1 and 2 for VPS2 from 107 and 108 to 115 and 116 (see "Extension Number of VPS Port 1" and "Extension Number of VPS Port 2" in Table 73 in B7.3 PBX Interface Parameters).

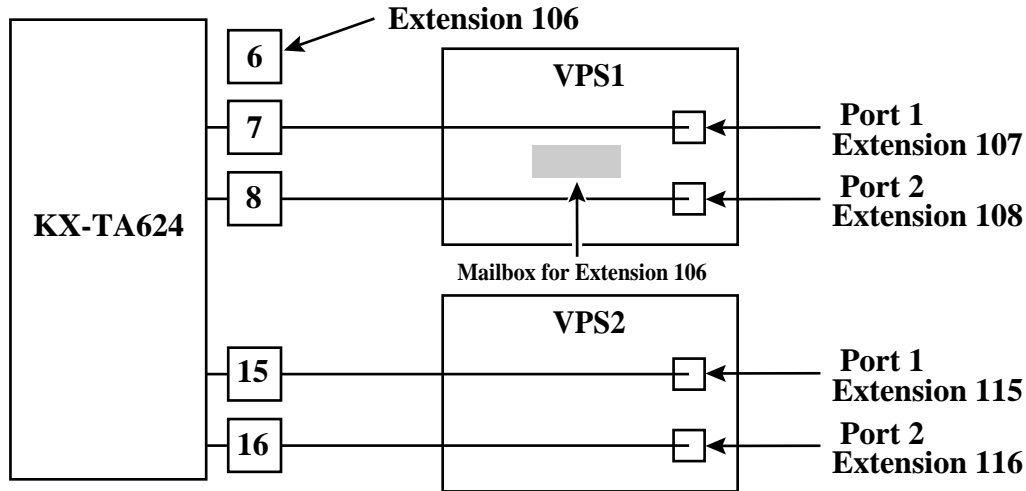

TEST: Press the INTERCOM button and then [107]. If the VPS answers, you have an APT connection.

Set the DIP Switch to position 0 after initialization is complete.

The required programming is complete and the VPS and KX-TA624 should be able to communicate through Digital Integration.

When running the Quick Setup command (Section 5 CUSTOMIZING THE SYSTEM) from the VPS, the PBX transmits the station information automatically. This saves time when programming the VPS.

4.3 CONNECTING THE VPS WITH THE PANASONIC KX-TD816, KX-TD1232, KX-TA1232 AND KX-TD308

Notes

- *Do not use system programs [106] or [602] for DPT Integration.*
- *The next 2 sections (4.3.1 KX-TD1232 Software Verification and Programming for DPT Integration via the Manager's Extension and 4.3.2 KX-TD1232 Software Verification and Programming for DPT Integration via the Operating and Maintenance Tool) are for the KX-TD1232 as examples. Please refer to them for the KX-TD816 or KX-TA1232.*
- *And the following Section (4.3.3 KX-TD308 Software Verification and Programming for DPT Integration via the Manager's Extension) is for the KX-TD308.*

4.3.1 KX-TD1232 Software Verification and Programming for DPT Integration via the Manager's Extension

It is important that the KX-TD1232 has the proper software level to allow DPT Integration with the VPS. Follow the procedures below to confirm the software level, then complete the required programming before starting up the VPS.

Note

Two methods of programming are available on the KX-TD1232. The instructions below show how to program without the operating and maintenance tool. For instructions on programming with the operating and maintenance tool, please see 4.3.2 KX-TD1232 Software Verification and Programming for DPT Integration via the Operating and Maintenance Tool.

All of the following procedures must be done after entering system programming. Refer to the KX-TD1232 Programming Guide or Installation Manual for instructions on how to enter the system programming mode.

Software Verification

1. Verify Software—If you are configuring a 2-cabinet system, remember to check both cabinets. The software must be the same in each. Check the software version of the KX-TD1232 using System Program [116].

Example: P231UYMMDDA

The underlined digits represent the software production date code (year, month, day). For DPT Integration, the software version of the PBX must be P231U or higher. (For KX-TD816, the version must be P301O or higher; for KX-TA1232, the version must be P831AA or higher.)

If the software version of the PBX is lower than this, you may not be able to utilize some of the features available only with DPT Integration. For more information, call National Parts Center at 1-800-833-9626.

*From the **SYS-PGM NO ?** screen:*

- a) Enter [116].**
- b) Press the NEXT button (SP-PHONE).**
- c) Enter the system number ([0] or [1], master/slave).** The system displays the ROM version and the date it was created.

This version must be P231U or higher for DPT Integration to be utilized (both systems if system connection is used).

- 2. Set the date and time using System Program [000].**
- 3. Set PBX extension numbering using System Program [003].**
- 4. Assign the Voice Mail Port.** This program tells the PBX which jack will be connected to the VPS. This allows the PBX to send the proper DPT Integration information to those ports.
 - *KX-TVS50 (2 ports): assign 1 jack*

Note

If you are configuring a 2-cabinet system, all Voice Mail Ports should be assigned to either the Master or Slave System.

*From the **SYS-PGM NO ?** screen:*

- a) Enter [117].**
- b) Press the NEXT button (SP-PHONE).**
Screen output: M: # # # #
- c) Enter the jack numbers (02-64) of the ports you will use for Voice Mail.**
- d) Press STORE.**
- e) Press END (HOLD) when finished.**

Conditions: *Jack 01 cannot be used as a Voice Mail port. A jack programmed as a Manager Extension (System Program [006]) cannot be used in this program.*

- 5. Skip this step unless setting flexible numbering.**

System Program [118] (Voice Mail Extension Number Assignment) is automatically set. This program allows you to assign an extension number to each Voice Mail port. Since a jack connected to the VPS provides 2 extensions, this enables you to assign extension numbers to each port. You can assign any extension number that is not already assigned to another port. To reach the VPS, users dial these extension numbers. It is not necessary to change the default programming for the extensions 165 and 166.

*From the **SYS-PGM NO ?** screen:*

- a) Enter [118].
- b) Press the **NEXT** button (SP-PHONE).
Screen output: VM NO? →
- c) Press the **NEXT** button (SP-PHONE).
Screen output: VM-01:#_ _ -1: 165
(_ _ = the port number you entered in program 117)
- d) Enter the **Extension Number** that you want this port to have.
 (The default extension number for port 1: 165; port 2: 166)
- e) Press **STORE**.
- f) Repeat steps c, d, and e until all extension numbers are entered.

Conditions: *No 2 jacks on the system can have the same extension number. If you try to enter a number that is already assigned, you will hear an error tone. Each digital extension connected provides 2 Voice Mail ports and must have 2 different extension numbers assigned.*

6. **Connect** the **jack** assigned in Step 4 to the VPS.
7. **Connect** your **personal computer** to the VPS and start your communication software (i.e., HyperTerminal, Procomm Plus, Smartcom...).
Communication Parameters: 9600, 8 Bit, None, 1
8. **Disconnect** the power from the VPS and **set** the **DIP Switch** to **position 5**.

Only perform this step when initially setting up the system.

CAUTION

*Setting the **DIP Switch** to **position 5** will default the **Voice Processing System**, resulting in a loss of all user programming and voice messages (except **User 1** and **User 2** prompts).*

9. **Plug in** and **power up** the VPS and wait approximately 2.5 min while the system initializes.

Before starting the VPS, make sure all installation and line connections have been done as described in Section 2 INSTALLATION.

The calls to the VPS can be processed after the Power Indicator stops flashing. After turning the power on, the system starts up in the following sequence:

- *The Power Indicator light goes on.*
- *The Power Indicator light begins to flash.*
- *"Checking Flash Memory Cards" is displayed on the screen.*

Screen output:

Checking Flash Memory Cards.
Please wait...
PORT TEST...
SYSTEM SETUP
1... 2... 3...

- The VPS tests the CPU card, the flash memory, and the ports until "1...2...3..." is displayed.
- Active ports are displayed on the screen.

Screen output:

Active COs: 1 2
DPT Interface Connection is Established
**** ON LINE MODE ****

The display will alert you if System Setup is not completed successfully.

Screen output:

Active COs: 1 2
DPT Interface Connection is not Established
**** OFF LINE MODE ****

This message will appear when the DPT connection between the VPS and telephone system cannot be established.

Possible causes of the message: "DPT Interface Connection is not Established"

Table 16

Cause	Remedy
The PBX is not a correct type. Since the VPS is configured to communicate with the default PBX type (the KX-TA series under APT Integration), this message will always appear when connecting to another type of PBX.	Connect a correct PBX and set the PBX type by using Quick Setup (see Section 5 CUSTOMIZING THE SYSTEM).
The cabling between the PBX extension ports and the VPS is not 4-wire or is improperly connected.	Confirm the cabling is connected as described in Section 2 INSTALLATION.
The PBX is a correct type but does not have the proper software level to support APT/DPT Integration.	Contact National Parts Center at 1-800-833-9626 or use Inband Integration under hardware settings.
The PBX is not programmed properly to support APT/DPT Integration.	Do required integration programming as described in this chapter.

10. Start up completed.

- a) The Power Indicator light stops blinking when the start-up has been successful. (The delay varies according to the system's condition.)
- b) ****ON LINE MODE**** is displayed.
- c) System prompt [**>**] is displayed on the screen. To enter system administration, **Press ENTER**. All parameters can be set through the menu-driven program.

11. Go to the *System Administration Top Menu*. Select [**5**] and **Press ENTER**, or **Type [3]** then **QSET** and **Press ENTER** for Quick Setup and follow the Auto Configuration Instructions.

TEST: Press the INTERCOM button and then [165]. If the VPS answers, you have a DPT connection.

Set the DIP Switch to position 0 after initialization is complete.

The required programming is complete and the VPS and KX-TD1232 should be able to communicate through DPT Integration.

We recommend that the KX-TD1232 system has any optional extension cards installed and telephones connected before starting the VPS.

When running the Quick Setup command (Section 5 CUSTOMIZING THE SYSTEM) from the VPS, the PBX transmits the station information automatically. This saves time when programming the VPS.

4.3.2 KX-TD1232 Software Verification and Programming for DPT Integration via the Operating and Maintenance Tool

Follow these steps after communication between the KX-TD1232 and the programming software has been established. Refer to the Operating and Maintenance manual for connection information.

1. Check the software version.
 - a) Go to the *Main Menu*. Press the ALT key and the letter [V] at the same time.
 - b) Verify the Operating and Maintenance version being used.

Sample display: *Connect DSHS: KX-TD1232*
 ROM Version: [---P231UxxxxxB] CAN
 DB data (PC): Empty
 Version: 4.03A5 [0008301332] MUK

This version must be 4.0xA5 or higher to program the KX-TD1232 for DPT Integration.

Note

If you have an older version of the maintenance tool but have the correct ROM version in the system, you may still program the KX-TD1232 but you must program using the Manager's Extension.

- c) Verify the ROM version of the KX-TD1232.

Example: P231UYMMDDB

This version must be at least version P231U or higher for DPT Integration to be utilized (both systems if system connection is being used).

(For KX-TD816, the version must be P301O or higher; for KX-TA1232, the version must be P831AA or higher.)

If the software version of the PBX is lower than this, you may not be able to utilize some of the features available only with DPT Integration. For more information, call National Parts Center at 1-800-833-9626.

In the example above, the underlined digits represent the software production date code (year, month, day).

- 2. Go to the *Main Menu*. Choose "System Data Programming" (BATCH [1] or INTERACTIVE [2]).**

Main Menu

1. System Data Programming (BATCH)
 2. System Data Programming (INTERACTIVE)
 3. Disk File Management
 4. DSHS Management
 5. DSHS Connect/Disconnect
 6. Quit
- Select the number : []

- 3. Choose "System" from the *System Data Programming Main Menu*.**

System Data Programming Main Menu

1. Line
 2. Station
 - 3. System**
 4. Toll Restriction
 5. ARS
 6. Aux. Ports
 7. Additional Function
 8. Caller ID
- Select the number : [**3**]

- 4. Choose "Voice Mail Integration" from the *System Menu*.**

System Menu

- | | |
|-----------------------------------|-----------------------------|
| 01. Day/Night | 14. Opera/Manager/EXT Group |
| 02. Class of Service | 15. Miscellaneous |
| 03. Emergency/Quick Dial | 16. Caller ID Modification |
| 04. Speed Dial | 17. Switch Type |
| 05. Absent Message | 18. DID |
| 06. Flexible Numbering | 19. Lunch/Break Time |
| 07. Account Code | 20. System Time |
| 08. Special Carrier | 21. Version |
| 09. Timer | 22. ISDN Card |
| 10. Voice Mail | 23. T1 Card |
| 11. Voice Mail Integration | 24. T1 Minor Error |
| 12. UCD | |
| 13. Phantom | |

Select the number: [**11**]

- 5. First, enter the port numbers that will be connected to the VPS. If desired, change the default extension numbers of the Voice Mail ports.**

Voice Mail Integration

VM Port No.	Master <u>[30]</u> [] [] [] [] [] []								
	Slave [] [] [] [] [] [] [] [] []								
VM	Jack	EXT	Name	EXG	VM	Jack	EXT	Name	EXG
01	30-1	[165]	[V.MAIL01]	[1]	13	-1	[171]	[V.MAIL13]	[1]
02	30-2	[166]	[V.MAIL02]	[1]	14	-2	[172]	[V.MAIL14]	[1]
03	-1	[167]	[V.MAIL03]	[1]	15	-1	[173]	[V.MAIL15]	[1]
04	-2	[168]	[V.MAIL04]	[1]	16	-2	[174]	[V.MAIL16]	[1]
05	-1	[169]	[V.MAIL05]	[1]	17	-1	[175]	[V.MAIL17]	[1]
06	-2	[170]	[V.MAIL06]	[1]	18	-2	[176]	[V.MAIL18]	[1]
07	-1	[177]	[V.MAIL07]	[1]	19	-1	[179]	[V.MAIL19]	[1]
08	-2	[178]	[V.MAIL08]	[1]	20	-2	[180]	[V.MAIL20]	[1]
09	-1	[181]	[V.MAIL09]	[1]	21	-1	[185]	[V.MAIL21]	[1]
10	-2	[182]	[V.MAIL10]	[1]	22	-2	[186]	[V.MAIL22]	[1]
11	-1	[183]	[V.MAIL11]	[1]	23	-1	[187]	[V.MAIL23]	[1]
12	-2	[184]	[V.MAIL12]	[1]	24	-2	[188]	[V.MAIL24]	[1]

6. Step 6 should only be done if the VPS is going to answer all incoming Central Office lines directly.

Return to the System Data Programming Main Menu. Select "Line" and then select "CO Line Setting 1". Program all lines DIL to the first extension of the Voice Mail hunt group.

CO Line Setting

CO No	C O N	T R G	D I A L	D T M F	P S	C I D	CPC Detection Mode	CPC Out	DIL 1:1 EXT No Day	DIL 1:1 EXT No Night	R E V	DIL 1:1 Lunch Group	DIL 1:1 Break Group
01	Y	[1]	D	80	10	N	Disable	Disable	<u>EXT[165]</u>	<u>EXT[165]</u>	Reg.	[]	[]
02	Y	[2]	D	80	10	N	Disable	Disable	<u>EXT[165]</u>	<u>EXT[165]</u>	Reg.	[]	[]
03	Y	[3]	D	80	10	N	Disable	Disable	<u>EXT[165]</u>	<u>EXT[165]</u>	Reg.	[]	[]
04	Y	[4]	D	80	10	N	Disable	Disable	<u>EXT[165]</u>	<u>EXT[165]</u>	Reg.	[]	[]
05	Y	[5]	D	80	10	N	Disable	Disable	<u>EXT[165]</u>	<u>EXT[165]</u>	Reg.	[]	[]
06	Y	[6]	D	80	10	N	Disable	Disable	<u>EXT[165]</u>	<u>EXT[165]</u>	Reg.	[]	[]
07	Y	[7]	D	80	10	N	Disable	Disable	<u>EXT[165]</u>	<u>EXT[165]</u>	Reg.	[]	[]
08	Y	[8]	D	80	10	N	Disable	Disable	<u>EXT[165]</u>	<u>EXT[165]</u>	Reg.	[]	[]
09	Y	[8]	D	80	10	N	Disable	Disable	<u>EXT[165]</u>	<u>EXT[165]</u>	Reg.	[]	[]
10	Y	[8]	D	80	10	N	Disable	Disable	<u>EXT[165]</u>	<u>EXT[165]</u>	Reg.	[]	[]
11	Y	[8]	D	80	10	N	Disable	Disable	<u>EXT[165]</u>	<u>EXT[165]</u>	Reg.	[]	[]
12	Y	[8]	D	80	10	N	Disable	Disable	<u>EXT[165]</u>	<u>EXT[165]</u>	Reg.	[]	[]

7. Follow steps 5-11 in 4.3.1 KX-TD1232 Software Verification and Programming for DPT Integration via the Manager's Extension.

The required programming is now complete and the VPS and KX-TD1232 should be able to communicate through DPT Integration.

We recommend that the KX-TD1232 system has any optional extension cards installed and telephones connected before starting the VPS.

When running the Quick Setup command (Section 5 CUSTOMIZING THE SYSTEM) from the VPS, the PBX transmits the station information automatically. This saves time when programming the VPS.

4.3.3 KX-TD308 Software Verification and Programming for DPT Integration via the Manager's Extension

It is important that the KX-TD308 has the proper software level to allow DPT Integration with the VPS. Follow the procedures below to confirm the software level, then complete the required programming before starting up the VPS.

All of the following procedures must be done after entering system programming. Refer to the KX-TD308 Programming Guide or Installation Manual for instructions on how to enter the system programming mode.

Software Verification

1. Verify Software—check the software version of the KX-TD308 using System Program [116].

Example: P871FYMMDDA

The underlined digits represent the software production date code (year, month, day). For DPT Integration, the software version of the PBX must be P871F or higher.

If the software version of the PBX is lower than this, you may not be able to utilize some of the features available only with DPT Integration. For more information, call National Parts Center at 1-800-833-9626.

From the SYS-PGM NO ? screen:

- a) Enter [116].
- b) Press the NEXT button (SP-PHONE).
- c) The system displays the ROM version and the date it was created.
This version must be P871F or higher for DPT Integration to be utilized.

2. Set the date and time using System Program [000].

3. **Set PBX extension numbering using System Program [003].**

4. **Assign the Voice Mail Port.** This program tells the PBX which jack will be connected to the VPS. This allows the PBX to send the proper DPT Integration information to those ports.

- *KX-TVS50 (2 ports): assign 1 jack*

*From the **SYS-PGM NO ?** screen:*

- a) **Enter [117].**
- b) **Press the NEXT button (SP-PHONE).**
Screen output: M: # #
- c) **Enter the jack number (2-8)** of the port you will use for the Voice Mail.
- d) **Press STORE.**
- e) **Press END (HOLD)** when finished.

Conditions: *Jack 01 cannot be used as a Voice Mail port. A jack programmed as a Manager Extension (System Program [006]) cannot be used in this program.*

5. **Skip this step unless setting flexible numbering.**

System Program [118] (Voice Mail Extension Number Assignment) is automatically set. This program allows you to assign an extension number to each Voice Mail port. Since a jack connected to the VPS provides 2 extensions, this enables you to assign extension numbers to each port. You can assign any extension number that is not already assigned to another port. To reach the VPS, users dial these extension numbers. It is not necessary to change the default programming for the extensions 295 and 296.

*From the **SYS-PGM NO ?** screen:*

- a) **Enter [118].**
- b) **Press the NEXT button (SP-PHONE).**
Screen output: VM NO? →
- c) **Press the NEXT button (SP-PHONE).**
Screen output: VM-1: #_ _ -1: 295
(_ _ = the port number you entered in program 117)
- d) **Enter the extension number** that you want this port to have.
(The default extension number for port 1: 295; port 2: 296)
- e) **Press STORE.**
- f) Repeat steps c, d, and e until all extension numbers are entered.

Conditions: *No 2 jacks on the system can have the same extension number. If you try to enter a number that is already assigned, you will hear an error tone. Each digital extension connected provides 2 Voice Mail ports and must have 2 different extension numbers assigned.*

6. **Connect** the **jack** assigned in Step 4 to the VPS.

7. **Connect** your **personal computer** to the VPS and start your communication software (i.e., HyperTerminal, Procomm Plus, Smartcom...).
Communication Parameters: 9600, 8 Bit, None, 1

8. **Disconnect** the **power** from the VPS and **set** the **DIP Switch** to **position 5**.

Only perform this step when initially setting up the system.

CAUTION

Setting the DIP Switch to position 5 will default the Voice Processing System, resulting in a loss of all user programming and voice messages (except User 1 and User 2 prompts).

9. **Plug in** and **power up** the VPS and wait approximately 2.5 min while the system initializes.

Before starting the VPS, make sure all installation and line connections have been done as described in Section 2 INSTALLATION.

The calls to the VPS can be processed after the Power Indicator stops flashing.

After turning the power on, the system starts up in the following sequence:

- *The Power Indicator light goes on.*
- *The Power Indicator light begins to flash.*
- *"Checking Flash Memory Cards" is displayed on the screen.*

Screen output:

Checking Flash Memory Cards.
Please wait...
PORT TEST...
SYSTEM SETUP
1... 2... 3...

- *The VPS tests the CPU card, the flash memory, and the ports until "1...2...3..." is displayed.*
- *Active ports are displayed on the screen.*

Screen output:

Active COs: 1 2
DPT Interface Connection is Established
**** ON LINE MODE ****

The display will alert you if System Setup is not completed successfully.

Screen output:

Active COs: 1 2
DPT Interface Connection is not Established
**** OFF LINE MODE ****

This message will appear when the DPT connection between the VPS and telephone system cannot be established.

Possible causes of the message: "DPT Interface Connection is not Established"

Table 17

Cause	Remedy
The PBX is not a correct type. Since the VPS is configured to communicate with the default PBX type (the KX-TA series under APT Integration), this message will always appear when connecting to another type of PBX.	Connect a correct PBX and set the PBX type by using Quick Setup (see Section 5 CUSTOMIZING THE SYSTEM).
The cabling between the PBX extension ports and the VPS is not 4-wire or is improperly connected.	Confirm the cabling is connected as described in Section 2 INSTALLATION.
The PBX is a correct type but does not have the proper software level to support APT/DPT Integration.	Contact National Parts Center at 1-800-833-9626 or use Inband Integration under hardware settings.
The PBX is not programmed properly to support APT/DPT Integration.	Do required integration programming as described in this chapter.

10. Start up completed.

- a) The Power Indicator light stops blinking when the start-up has been successful. (The delay varies according to the system's condition.)
- b) ****ON LINE MODE**** is displayed.
- c) System prompt [**>**] is displayed on the screen. To enter system administration, **Press ENTER**. All parameters can be set through the menu-driven program.

11. Go to the System Administration Top Menu. Select [5] and Press ENTER, or Type [3] then QSET and Press ENTER for Quick Setup and follow the Auto Configuration Instructions.

TEST: Press the INTERCOM button and then [295]. If the VPS answers, you have a DPT connection.

Set the DIP Switch to position 0 after initialization is complete.

The required programming is complete and the VPS and KX-TD308 should be able to communicate through DPT Integration.

We recommend that the KX-TD308 system has any optional extension cards installed and telephones connected before starting the VPS.

When running the Quick Setup command (Section 5 CUSTOMIZING THE SYSTEM) from the VPS, the PBX transmits the station information automatically. This saves time when programming the VPS.

4.4 COMMON DIGITAL INTEGRATION FEATURES AND SETUP PROCEDURES

The following features can be used on any KX-T proprietary telephone (7000 series analog; 7200/7400 series digital). KX-T7000 series is used with the KX-TA624. The KX-T7200 and KX-7400 series are used with the KX-T series PBX that uses DPT Integration.

4.4.1 Live Call Screening (LCS) Programming

LCS notifies subscribers of incoming messages to their mailboxes. The notification method is programmable for hands-free or private. Hands-free allows the user to monitor a recording through the speakerphone and, if desired, intercept the call by lifting the handset. The private mode notifies the user with an alert tone when a message is being recorded. By pressing the LCS button, the user can monitor the message and intercept the call by going off-hook. System Programming also determines whether the mailbox continues to record after the user intercepts the call.

4.4.2 Live Call Screening Password Assignment

To allow the Live Call Screening feature to work at an extension, the extension must have the LCS button lit. To light this button on the telephone, press the LCS button, then enter the password. This password prevents others from activating the LCS feature and listening to the messages as they are being left. (It is not necessary to enter PITS Programming to activate this feature.)

1. **Lift** the handset or **Press** the **SP-PHONE** button.
2. **Dial** the feature number **[77*]** (for KX-TA624) or **[799]** (for KX-T series PBX that uses DPT Integration) from system program.
3. **For KX-TA624**
Press a 3-digit password (**[000]-[999]**) twice and #.
For KX-T series PBX that uses DPT Integration
Press a 3-digit password (**[000]-[999]**) twice.
You will hear a confirmation tone, then a dial tone.
Screen output: The 3-digit password you entered is displayed.
4. **Hang up** or **Press** the **SP-PHONE** button.
5. Repeat these steps for each telephone.

4.4.3 Live Call Screening Password Canceling

To cancel the password, follow the procedure below. (It is not necessary to enter PITS Programming to activate this feature).

1. **Lift** the handset or **Press** the **SP-PHONE** button.
2. **Dial** the feature number [**77***] (for KX-TA624) or [**799**] (for KX-T series PBX that uses DPT Integration) from system program.
3. *For KX-TA624*
Press a 3-digit password ([**000**]-[**999**]) once and #.
For KX-T series PBX that uses DPT Integration
Press a 3-digit password ([**000**]-[**999**]) once.
You will hear a confirmation tone, then a dial tone.
Screen output: Password Cancel
4. **Hang up** or **Press** the **SP-PHONE** button.
5. Repeat these steps for each telephone.

4.4.4 Live Call Screening Recording Mode Assignment via System Programming

This program allows the VPS to continue recording the conversation in the mailbox after the extension intercepts the call during the Live Call Screening.

1. **Enter** [**620**] (for KX-TA624) or [**610**] (for KX-T series PBX that uses DPT Integration) from system program.
2. **Press** the **NEXT** button (SP-PHONE).
Screen output: Jack No.? →
3. **Enter** the **jack number**.
Screen output: # _ _ :Stop Rec
(_ _ = the jack number you entered)
4. **Press** the **SELECT** button (AUTO-ANSWER) until the desired selection is displayed.
5. **Press** **STORE**.
6. **Press** the **NEXT** button (SP-PHONE).
7. Repeat the steps 4 to 6 until all jacks are programmed.

4.4.5 Live Call Screening Private/Hands-Free Mode Assignment via Station Programming

This program assigns a VPS response for when a message is being left in a mailbox. It determines whether an alert tone is sent or whether the recorded message is played through the built-in speaker of the extension. The default mode is hands-free. (This is a station level program and should be done at each individual telephone.)

1. Enter Station Programming:

For KX-TA624

With the phone on-hook, **Set** the **MEMORY** switch to "**PROGRAM**".

(Display changes to PITS-PGM Mode.)

For KX-T series PBX that uses DPT Integration

a. With the phone on-hook, **Press** the **PROGRAM** button.

b. **Dial [99]**. (Display changes to PITS-PGM Mode.)

2. Dial the code for the mode you want this telephone to have.

Hands-Free = **Press #11** (for KX-TA624) or **[71]** (for KX-T series PBX that uses DPT Integration).

Private = **Press #12** (for KX-TA624) or **[72]** (for KX-T series PBX that uses DPT Integration).

Screen output: Hands-Free or Private

3. Press STORE.

4. *For KX-TA624*

Set the **MEMORY** switch to "**SET**".

For KX-T series PBX that uses DPT Integration

Press the **PROGRAM** button or lift the handset.

5. Repeat these steps for each telephone.

Conditions: None

For the KX-T series PBX that uses DPT Integration:

A single-line telephone that is connected to the same extension as a proprietary telephone can also be used to monitor an incoming message. Be sure that Live Call Screening on the connected proprietary telephone has been activated. This feature is useful when you are using a cordless telephone. The handset sounds an alert tone to let you know that a message is being recorded. To intercept the call, flash the hook.

4.4.6 Live Call Screening Button Assignment via Station Programming

For the Live Call Screening feature to work at an extension, the extension must have an LCS button lit at the time of the message reception. This key must either be a DSS/BLF or CO key with a lamp. Follow the procedure below to assign an LCS button on an extension. (This is a station level program and should be done at each individual telephone.)

1. Enter PITS Programming:
For KX-TA624
With the phone on-hook, **Set** the **MEMORY** switch to "**PROGRAM**".
(Display changes to PITS-PGM Mode.)
For KX-T series PBX that uses DPT Integration
 - a. With the phone on-hook, **Press** the **PROGRAM** button.
 - b. **Dial [99]**. (Display changes to PITS-PGM Mode.)
2. **Press** the desired **FLEXIBLE (CO or DSS/BLF)** button you want to assign as the LCS button.
3. **Dial [92]**.
Screen output: LCS
4. **Press STORE**.
5. *For KX-TA624*
Set the **MEMORY** switch to "**SET**".
For KX-T series PBX that uses DPT Integration
Press the **PROGRAM** button or lift the handset.
6. Repeat these steps for each telephone.

4.4.7 Live Call Screening Cancel Button Assignment via Station Programming

This button assignment allows you to assign a Flexible (CO, DSS) button as a Live Call Screening Cancel button.

1. Enter PITS Programming:
For KX-TA624
With the phone on-hook, **Set** the **MEMORY** switch to "**PROGRAM**".
(Display changes to PITS-PGM Mode.)
For KX-T series PBX that uses DPT Integration
 - a. With the phone on-hook, **Press** the **PROGRAM** button.
 - b. **Dial [99]**. (Display changes to PITS-PGM Mode.)
2. **Press** the **Flexible (CO, DSS)** button that you wish to assign as a Live Call Screening Cancel button.
3. **Dial [93]**.
Screen output: LCS Cancel

4. **Press STORE.** The STORE indicator light turns on.
The display shows the initial programming mode.
5. **For KX-TA624**
Set the MEMORY switch to "SET".
For KX-T series PBX that uses DPT Integration
Press the PROGRAM button or lift the handset.
6. Repeat these steps for each telephone.

The Live Call Screening Cancel Button Assignment is optional; Live Call Screening can also be canceled by **Pressing** the FLASH button.

4.4.8 Two-Way Recording Button Assignment via Station Programming

For the Two-Way Recording feature to work at an extension, the extension must have a TWR button on it. This key must either be a DSS/BLF or CO key with a lamp. Follow the procedure below to assign a TWR button on an extension. (This is a station level program and should be done at each individual telephone.)

1. Enter PITS Programming:
For KX-TA624
With the phone on-hook, Set the MEMORY switch to "PROGRAM".
(Display changes to PITS-PGM Mode.)
For KX-T series PBX that uses DPT Integration
 - a. With the phone on-hook, Press the PROGRAM button.
 - b. Dial [99]. (Display changes to PITS-PGM Mode.)
2. Press the Flexible button (CO or DSS/BLF) that you want to assign as the TWR button.
3. Dial [90].
Screen output: 2Way-Rec:
4. Dial the Voice Mail extension number.
Screen output: 2Way-Rec: _ _ _
(_ _ _ = The extension number you entered).
5. Press Store.
6. **For KX-TA624**
Set the MEMORY switch to "SET".
For KX-T series PBX that uses DPT Integration
Press the PROGRAM button or lift the handset.
7. Repeat these steps for each telephone.

Conditions: *This button must be a CO or DSS/BLF key to be programmed as a TWR button. If this key is pressed when all Voice Mail ports are busy, the user will hear a reorder tone.*

4.4.9 Two-Way Transfer Button Assignment via Station Programming

For the Two-Way Transfer feature to work at an extension, the extension must have a TWT button on it. This key must either be a DSS/BLF or CO key with a lamp. Follow the procedure below to assign a TWT button on an extension. (This is a station level program and should be done at each individual telephone.)

1. Enter PITS Programming:

For KX-TA624

With the phone on-hook, Set the **MEMORY** switch to "**PROGRAM**".

(Display changes to PITS-PGM Mode.)

For KX-T series PBX that uses DPT Integration

a. With the phone on-hook, Press the **PROGRAM** button.

b. Dial **[99]**. (Display changes to PITS-PGM Mode.)

2. Press the desired **FLEXIBLE (CO or DSS/BLF)** button that you want to assign as the TWT button.

3. Dial **[91]**.

Screen output: 2Way-Trans:

4. Dial the **Voice Mail extension number**.

Screen output: 2Way-Trans: _ _ _

(_ _ _ = The extension number you entered).

5. Press **STORE**.

6. *For KX-TA624*

Set the **MEMORY** switch to "**SET**".

For KX-T series PBX that uses DPT Integration

Press the **PROGRAM** button or lift the handset.

7. Repeat these steps for each telephone.

Conditions: *This button must be a CO or DSS/BLF key to be programmed as a TWT button. When all Voice Mail ports are busy and this key is pressed, the user will hear reorder tone.*

4.4.10 Voice Mail Transfer Button Assignment via Station Programming

This feature allows an extension user to transfer calls directly to a Voice Mailbox. This is available with both Digital and Inband Integrations.

1. Enter PITS Programming:

For KX-TA624

With the phone on-hook, Set the **MEMORY** switch to "**PROGRAM**".

(Display changes to PITS-PGM Mode.)

For KX-T series PBX that uses DPT Integration

- a. With the phone on-hook, **Press** the **PROGRAM** button.
- b. **Dial [99]**. (Display changes to PITS-PGM Mode.)
2. **Press** the desired **Flexible (CO or DSS/BLF)** button that you want to assign as the VTR button.
3. **Dial [94]** (for KX-TA624) or **[8]** (for KX-T series PBX that uses DPT Integration).
Screen output: VTR
4. **Dial the Voice Mail extension number.**
Screen output: VTR-___
(___ = *The extension number you entered*).
5. **Press STORE.**
6. **For KX-TA624**
Set the **MEMORY** switch to "SET".
For KX-T series PBX that uses DPT Integration
Press the **PROGRAM** button or lift the handset.
7. Repeat these steps for each telephone.

Conditions: *This button must be a CO or DSS/BLF key to be programmed as a VTR button. When all Voice Mail ports are busy and this key is pressed, the user will hear reorder tone.*

4.4.11 Live Call Screening Activation

To activate the Live Call Screening status, follow the steps below.

1. **Press** the assigned **LCS Button**.
2. **Press** the assigned **LCS Password**.
3. Confirm the assigned **LCS Button** is red-on.
4. Repeat these steps for each telephone.

Conditions: *To activate the Live Call Screening features, it is necessary to light the LCS button after assigning the LCS password and LCS button.*

4.4.12 Live Call Screening Password Control

This feature allows Operator(s) and the Manager of the PBX to cancel the password for LCS at any extension. If a user forgets the preprogrammed password, Operator(s) and the Manager of the PBX can cancel the LCS password.

1. Enter PITS Programming:
For KX-TA624
With the phone on-hook, Set the **MEMORY** switch to "**PROGRAM**".
(Display changes to PITS-PGM Mode.)
For KX-T series PBX that uses DPT Integration
 - a. With the phone on-hook, Press the **PROGRAM** button.
 - b. Dial **[99]**. (Display changes to PITS-PGM Mode.)
2. Dial **[#2]** (for KX-TA624) or **[03]** (for KX-T series PBX that uses DPT Integration).
Screen output: Ext NO?
3. Dial the desired **Extension Number**, or Press **[*]** to remove all passwords (for KX-T series PBX that uses DPT Integration only).
4. Press **STORE**.
5. *For KX-TA624*
Set the **MEMORY** switch to "**SET**".
For KX-T series PBX that uses DPT Integration
Press the **PROGRAM** button or lift the handset.
6. Repeat these steps for each telephone.

4.4.13 Two-Way Recording into Mailbox

This feature allows extension users to record conversations into their mailboxes by pressing the Two-Way Recording (TWR) button.

4.4.14 Two-Way Transfer into Mailbox

This feature allows an extension user to record a conversation into another person's mailbox by pressing the Two-Way Transfer (TWT) button and dialing the mailbox number. This is commonly used by a person who is taking a detailed message for someone else and wants the message recorded in the mailbox at the same time.

Section 5
CUSTOMIZING THE SYSTEM

5.1 STARTING UP

5.1.1 Before Programming

1. Determine the customer's needs.
 - *Work with the owner, manager, and receptionist to build the Custom Service Greetings and Holiday Greetings.*
 - *Figure out which ports are to be answered by which greetings.*
 - *Check the software level of the PBX.*
2. Use "System Administration" and your personal computer for the startup sequence.
3. After the system becomes "on line", disconnect the CO lines going into the system until the greetings have been completed.
4. Work with the receptionist to record the system greetings. These are listed in Appendix D6 RECORDING MESSAGES.
 - *It is important to spend time training the receptionist. Making sure that the receptionist understands the system and is capable of answering basic questions will save you time in the end.*
 - *Show the receptionist how to transfer "General Delivery Mailbox" messages. See Appendix D2 MANAGING THE GENERAL DELIVERY MAILBOX.*

5.1.2 Quick Setup

Quick Setup provides a quick way to set the following programming items. Each of these must be initially set to start the VPS operation.

Notes

- ***Quick Setup requires VT100 emulation software.***
- ***Quick Setup cannot be performed in ASCII mode.***

1. *PBX type*
2. *Extension numbers of VPS ports*
3. *Extension numbers for mailboxes*
4. *Creating mailboxes*
5. *Port service setting*
6. *Password setting*
7. *Date and time setting*
8. *Activating the Quick Setup*

Depending on your PBX type, some steps will be skipped as shown below.

Table 18

PBX Type	Required Procedures
KX-T308/T616	1→2→3→4→5→6→7→8
KX-T123211D/T336/T96*	1→3→4→5→6→7→8
Non-Panasonic System	1→3→4→5→6→7→8
KX-TD816/TD1232/TA1232/TD308	1→4→5→6→8

* Not available in the United States.

5.1.3 Starting the Quick Setup

The sequence must be followed through to the end to take effect. If you press "\", you will have to start over. Quick setup may be performed again without erasing prior data.

Note

Depending on PBX extension numbering, the mailbox numbers might be 2- to 5-digit long.

At the *System Administration Top Menu*, **Type [5]** and **Press ENTER**, or **Type [3]** then **QSET** and **Press ENTER**. See 7.2.17 Quick Setup (QSET) for more information.

Screen output:

System Administration Top Menu → 5
 or
System Administration Top Menu → 3 → QSET

Quick Setup Utility for connection to Panasonic KX-T series telephone systems

This utility provides a quick way of programming the Voice Processing System to operate in a standard automated attendant or voice mail configuration when connected to a Panasonic KX-T series telephone system. The system will prompt you to enter, modify or confirm settings based upon which PBX type you select.

By entering the appropriate information in the following screens, the system sets PBX integration parameters, identifies the extension numbers connected to it, creates default mailboxes, sets its ports to handle callers with automated attendant or voice mail service, sets system passwords and sets the time and date. Finally, it confirms that you want to activate the system based on the information you entered, modified or confirmed.

To proceed, press Enter. To exit and cancel Quick Setup now, press \.

1. PBX Type

a) Press ENTER.

Screen output:

```

Quick Setup - PBX type
Please select your PBX type.
 1. KX-T308/KX-T616
 2. KX-T1232
 3. KX-T96
 4. KX-T336
 5. KX-TD816/KX-TD1232/KX-TA1232
 6. KX-TD308
 7. KX-TA series
 0. OTHERS
    
```

b) Select your PBX type. The required steps are different for some models. Go to the step indicated below for that type.

Table 19

1. KX-T308/616	Go to Step 2.
2. KX-T123211D, 3. KX-T96, 4. KX-T336, 0. Others	Go to Step 3.
5. KX-TD816/KX-TD1232/KX-TA1232, 6. KX-TD308, 7. KX-TA series	Go to Step 4.

Notes

- *APT Integration with the KX-TA624 will be activated automatically by selecting "7. KX-TA series".*
- *DPT Integration with the KX-TD816/KX-TD1232/KX-TA1232, or KX-TD308 will be activated automatically by selecting "5. KX-TD816/KX-TD1232/KX-TA1232", or "6. KX-TD308".*
- *APT/DPT Integration provides a quicker way to create mailboxes and set the time and date by transferring extension and time information from the PBX automatically.*

2. Extension Numbers of VPS Ports

Screen output:

```

Quick Setup - Assigned extension No. of VPS Port
Please enter extension number of VPS.
 1:          2:
Please enter extension numbers.
(2 digits) :=
          S: Next Screen
    
```

Enter extension numbers of VPS ports with 2-digit numbers. This improves the VPS integration with the KX-T308 or KX-T616 by allowing the VPS to discriminate between VPS extensions and non-VPS extensions.

Type [S] to go to the next screen.

3. Extension Numbers for Mailboxes

Screen output:

Quick Setup - Enter Extensions for Mailboxes				
What extensions need a mailbox on this system?				
1:110	2:111	3:112	4:113	5:114
6:115	7:116	8:117	9:118	10:119
11:120	12:121	13:122	14:123	15:124
16:125	17:126	18:127	19:128	20:129
21:130	22:131	23:132	24:133	25:134
26:135	27:136	28:137	29:138	30:139
<u>Please enter extension numbers.</u>				
:=				
P: Previous menu, N: Next menu, S: Next Screen				

Enter extension numbers of subscribers who need personal mailboxes (the VPS accepts any extension numbers within a 2- to 5-digit range). For example, to enter the extension number 101, **Press [101]** and **Press ENTER**. You can also enter multiple extensions. Enter the extensions from No.101 to No.110 by **Pressing [101-110]** and **Pressing ENTER**.

The VPS will create mailboxes with the extension numbers entered. (See Step 4.)

4. Creating Mailboxes

To go to the next screen (S) or to change the menu (P or N), the cursor must be in the MBX column.

Screen output:

Quick Setup - Mailbox Editing				Page 1/4
Extension and mailbox list		Assigned 30	Vacant 0	
Ext	MBX	Owner (Last Name)	MAKE (Make/Delete)	
•••	: 101	••••••••••••••••••••	Make	
110	: 110	••••••••~	Make	
111	: 111	••••••~	Make	
112	: 112	••••••~	Make	
113	: 113	••••••~	Make	
114	: 114	••••••~	Make	
115	: 115	••••••~	Make	
116	: 116	••••••~	Make	
117	: 117	••••••~	Make	
•		•	•	
•		•	•	

P: Previous menu, N: Next menu, S: Next Screen

a) To create or discard mailboxes

In the "MAKE (Make/Delete)" field: **Type [M]** (Make) to create the mailbox; **Type [D]** (Delete) to discard the mailbox. If there are more than 30 mailboxes, the first 30 of them are displayed with "Make" and the rest are displayed with "Delete" (screen output: [Assigned 30, Vacant 0]).

To change the status of a mailbox from "Delete" to "Make", first change the status of a mailbox from "Make" to "Delete" (screen output: [Assigned 29, Vacant 1]). Then change the status from "Delete" to "Make".

b) Owner's last name

Up to 16 alphabetic characters can be assigned as an Owner's Last Name.

Note

- *Mailbox numbers displayed on this screen*

Panasonic KX-TD Series or KX-TA1232 System

The same numbers as the extensions of the KX-T series system that uses Digital Integration that were automatically transmitted to the VPS—Auto Configuration.

Other System

The same numbers as those of the extensions entered in step 3.

- ***The length of mailbox numbers***

The Message Manager mailbox (General Delivery Mailbox) might be 2- to 5-digit long (98, 998, 9998, or 99998).

The System Manager mailbox might be 2- to 5-digit long (99, 999, 9999, or 99999).

If both 3 and 4-digit extension numbers exist at the same time, the VPS will unify all mailbox numbers to 4-digit length by entering [0] at the end of all 3-digit numbers.

Example:

<i>Extension Numbers</i>	<i>Mailbox Numbers</i>
201	201(0) *
202	202(0) *
203	203(0)*
2000	2000
2001	2001
2002	2002

**The VPS puts [0] at the end of 3-digit numbers.*

Note

After creating mailboxes for subscribers by Quick Setup, the COS parameter "Authorization for Message Notification" (see Table 39 in B3 SYSTEM ADMINISTRATION—SETTING COS (CLASS OF SERVICE) PARAMETERS) for COS number 1 will be set to "Yes". It will stay "No" for COS number 2 through number 62.

To program mailbox parameters other than the extension numbers and Owner's Last Name (or First Name), see 5.5 SETTING MAILBOXES. The caller can use "Dial by Name" feature using the Owner's Last Name when in Automated Attendant Service or Voice Mail Service.

5. Port Service Setting

Screen output:

```

Quick Setup- Port Service Setting
All ports are currently set up to handle callers with standard automated atten-
dant operation, day and night mode, using the Custom Service feature (Custom
1). You can change the operation to standard Voice Mail (Custom 2) or leave it
as automated attendant. If necessary, Custom 1 and Custom 2 can be modified
under the menu 'Program -> Service Setting -> Custom Service.'

                Day Mode                Night Mode
PORT 1         Auto. Attend.            Auto. Attend.
PORT 2         Auto. Attend.            Auto. Attend.

                A: Auto. Attend., V: Voice Mail, S: Next Screen
                Auto. Attend. (using Custom 1), Voice Mail (using Custom 2)
    
```

Incoming Call Services for all ports (Day/Night) can be defined by this setting. Default values for all ports (Day/Night) are "Automated Attendant Service (Custom 1)". To select other incoming call services, go to "Setting Ports".

6. Password Setting

Screen output:

```

Quick Setup-Password Setting
System Administrator Password
(Maximum 10 characters)
NEW PASSWORD :=
VERIFICATION :=
System Reset/Clear Password
(Maximum 10 characters)
NEW PASSWORD :=
VERIFICATION :=
    
```

You can assign the System Administrator Password and System Reset/Clear Password in this screen, if necessary.

IMPORTANT

- *We strongly recommend that you set the password to 10 characters for maximum protection against hackers.*
- *Do not carelessly reveal the password to other persons.*
- *Please change the password periodically (for instructions, see 7.2.3 Set Password (PASS) in 7.2 UTILITY COMMANDS.)*

To go to the next screen without assigning the password, **Press ENTER.**

7. Date and Time Setting

Screen output:

```
Quick Setup-Time Setting
  Current time is 3:04, PM
    Enter new time (HH:MM, AM/PM) : =
  Current date is MON JAN-1-2001
    Enter new date (MM-DD-YY) : =
```

Enter the time (hour, minute in 2 digits, comma and A or P) and date (month, day and year in 2 digits).

To go to the next screen, **Press ENTER**.

8. Activating the Quick Setup

Screen output:

```
Quick Setup - Setup
To set up the mailbox and restart, select 'Yes.'
To cancel and exit, select 'No.'
1: Yes      2: No
```

To activate the Quick Setup, **Press [1]** and **Press ENTER**.

Note

To cancel the Quick Setup, Press [2] and Press ENTER. This cancels all changes made up to this point.

The VPS begins to change system programming data.

Screen output:

```
Quick-Setup
  To set up the mailbox and restart, select "Yes."
  To cancel and exit, select "No."
    1: Yes      2: No
Setup 101
```

Then "*PORT TEST...*" "*SYSTEM SETUP...*" and "*1...2...3...*" appear on the screen one by one.

Screen output:

```
PORT TEST ...
SYSTEM SETUP ...
1 ... 2 ... 3 ...
```

Screen output when Quick Setup is finished:

```
**ON LINE MODE**
>
```

5.2 PORT SETTING OPTIONS

Design each system according to the needs of your customer. You should be familiar with all options for port assignment so that customers get exactly what they need and expect. Each port can be assigned as Voice Mail, Interview Service, Automated Attendant, or Custom Service. Custom Service is the most flexible of all the services because it allows access to the other services by pressing one key. **We recommend programming all ports as Custom Service for caller convenience.**

5.2.1 Custom Service Setting Example

Custom Service incorporates all features of the Automated Attendant and Voice Mail. Custom Service offers callers a menu of single digits that they may use to reach the desired location quickly and easily.

Sample Custom Service Message

"If you know the extension number of the person you are calling, you can dial it at any time. For a list of extensions, Press [1]; to reach the sales section, Press [2]; to reach the service section, Press [3]; if you would like to place an order, Press [4]; all other callers, please wait and an operator will be right with you".

Sample Custom Service Tree

Create a tree to design a route that leads callers to the desired extension, mailbox, or next menu. This tree should include all available caller options and cannot be deeper than 8 layers. Moreover, callers cannot jump between Custom Service menus more than 8 times. Discuss available options with the customer before programming the system.

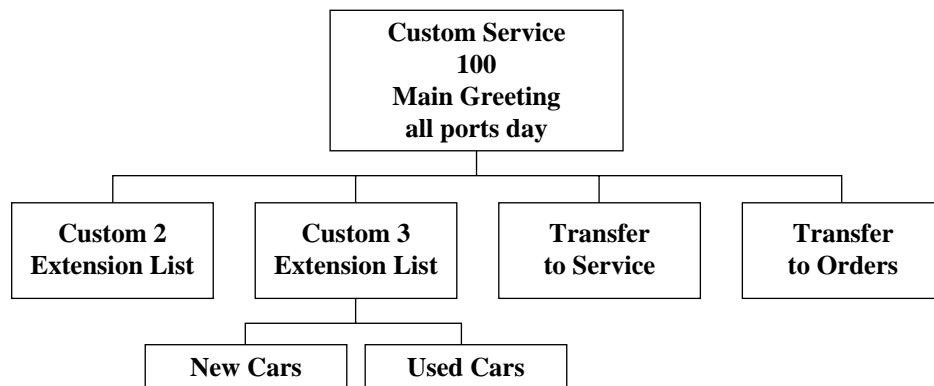

The top of the tree should include what callers will hear when they are first connected to the VPS. Then create a branch for each option until each caller option has been documented. Next, fill in each box with the action that it represents so you can easily remember what action corresponds to each keystroke.

Remember that it is possible and often necessary to have 1 custom service lead to another

custom service. For example, if someone presses [1] for sales, you might want another menu to say *"for new car sales, press [1]; for used car sales, press [2]"*. This way, callers are routed directly to the person best suited to handle them.

Sample Custom Service for Foreign Languages

If you are an airline or travel agency, your callers might not be fluent in English. You can easily accommodate several languages with Custom Service. For example, each key on the keypad (there are 12 keys) could be assigned to a language. Record Custom Service Menu 100 so that the caller can select a language with one-touch dialing. For example, the top menu could be: *"For English, press 1. For French, press 2. For Spanish, press 3. For German, press 4. For Japanese, press 5. For Chinese, press 6... etc."* (of course, selections should be recorded in their respective languages).

At the next level, create menus in each language for Day Mode. For example, Custom Service Menu 2 (the one for English callers) might be: *"For departure information, press 1. For arrival information, press 2. For reservations, press 3. To leave a message, press 4. To send a fax, press 5"*. Thus at this level (or at an even lower level) a caller can be guided in his native tongue to the right person (extension), the right message-taker (mailbox), or the right device (fax machine).

In parallel, create menus in each language for Night, Lunch, and Break Modes. For example, Custom Service Menu 16 for Night Mode might be: *"Sorry, we are closed for the day. Our regular business hours are from 9 am to 5 pm, Monday through Friday. If you would like to leave a message, press 1 now. If you would like to send a fax, press 2 now"*. Record a similar message for the other languages in each mode.

5.2.2 Custom Service Features

Time Service (1-5-2-2)

Set each day of the week for the correct Day, Night, Lunch, or Break Mode.

Intercom Paging (1-5-7-7)

This feature is only available with Digital Integration.

When needed, change the paging code for each of the paging groups.

Example for KX-TD1232: All sales telephones have been placed in extension group 3 in system program [602]. No hunting type assigned in system program [106]. Assign each salesperson's mailbox to a different COS in the VPS and assign the paging group to that COS. (This tells the VPS which paging group to dial). In the Intercom paging section, assign the number "333" to the paging group assigned to the sales dept.

Fax Management (1-5-7-8)

Assigns up to 2 fax machines that can be extensions from the PBX. If the CNG tone is heard, the VPS will automatically forward the call to the first fax machine. If the first fax machine is busy or does not answer (is out of paper), the VPS forwards the call to the second fax machine. This also allows to assign an extension as the fax manager to be notified on incoming faxes.

Disconnect Parameter (1-5-7-9)

Determines how many seconds of silence the VPS allows during a caller's message before disconnecting the call.

RS-232C Settings (1-6-1)

Allows the System Administrator to change the baud rate, parity bit, etc.

Port Setting (1-6-2)

Only to be used when connecting the VPS to a PBX other than a KX-T series PBX. Use the CPC control of the PBX for normal disconnect problems.

Dialing Parameters (1-6-3-1)

These parameters are set automatically when Quick Setup is conducted.

Most of the settings will be left unchanged. The only setting that will be changed quite often is the Transfer Sequence for the operator or the extension. By default, it is set at FX on APT/DPT Integration and FTX for Inband Integration. In other words, the voice processor dials the flash, waits for intercom tone and dials the extension number. By default, the VPS will stay on the line to monitor the status of the call. If the extension user answers, the voice processor will announce "*you have a call*" prior to releasing the call. This can be alleviated by adding the letter "A" or "D" to the sequence. "A" stands for answer; the call will be transferred without the announcement "*you have a call*". For a blind or unscreened transfer, add the letter "D" for disconnect.

5.2.3 Custom Service Programming

After you have finished constructing the tree, enter the *System Programming Custom Service Settings Menu*.

Access the *Custom Service Setting Menu* through the following sequence:

System Administration Top Menu:

Enter The Number: = **1** (Program)

Enter The Number: = **4** (Service Setting)

Enter The Number: = **2** (Custom Service)

The system then asks what Custom Service number you want to edit. Enter the desired number (1-100).

The *Custom Service* screen is displayed:

Program - Service Setting - Custom Service Setting - Custom 1 (Not recorded)

1. Description []
:=

2. Prompt Mode [System]
1:System 2:User1 3:User2 :=

3. Menu Repeat Cycle [3] (1-3 times) :=

4. Call Transfer Anytime [Extn.] (Extn./Mbx/No) :=

5. Wait for Second Digit (1-5 s) :=

6. No DTMF Input Operation [c] (a - f)

- a. Transfer to Mailbox
- b. Transfer to Extension
- c. Operator
- d. Exit
- e. Previous Menu
- f. Custom Service

Select Operation :=

7. Keypad Assignment

Keypad 0 [c]

a. Transfer to Mailbox	h. Call Transfer Service
b. Transfer to Extension	i. Subscriber Service
c. Operator	j. Department Dialing
d. Exit	k. Dial by Name
e. Previous Menu	l. Repeat Menu
f. Custom Service	m. Main Menu
g. Voice Mail Service	n. Fax Transfer

Enter data into the Custom Service menu; use the table below as a guide.

Table 20

Description	Value Range (Default)	Description/Function
Description	Up to 32 characters (None)	The information typed in this field is for reference only. Any ASCII character (except \) can be used.
Prompt Mode	1. System 2. User 1 3. User 2 (User 1)	Specifies the language that the caller will hear when calling this Custom Service.
Menu Repeat Cycle	1-3 Times (3)	Specifies the number of times the Custom Service menu will be repeated before the No DTMF Input entry is used.
Call Transfer Any Time	Extn./Mbx/No (Extn.)	<p>Specifies where a caller will be transferred when dialing an extension or mailbox number during the menu. If this entry is set to "Extn.", the caller will be transferred to the corresponding extension. If it is set to "Mbx", the caller will be sent directly to the corresponding mailbox. If it is set to "No", extension transfer and mailbox transfer are disabled; only 1-digit entries work (following the Custom Service menu).</p> <p>Note: This parameter should be set to "No" when Subscriber Service is specified as a Custom Service option and it is desired that digits can be entered very quickly to specify a mailbox. Therefore, in most cases, "No" is the best setting for this parameter. This is especially true if you do not want to explain "Call Transfer Any Time" in your Custom Service menu recording.</p>
Wait for Second Digit	1-5 s (1)	Used when the first digit of an extension is also a menu choice within the Custom Service. If a second digit is not dialed within the specified time, the menu choice is used.
No DTMF Input Operation	a-f (c)	Used when a caller does not dial anything when hearing the menu (usually rotary callers).
Keypad Assignment	a-n (* = d, 0 = c, others = None)	Specifies the action to be performed when a keypad digit is dialed. Callers can access specific services by pressing the appropriate keys on their telephones.

Keypad Assignment Options
Table 21

Entry	Function
a. Transfer to Mailbox	Allows the caller to leave messages in a specific mailbox.
b. Transfer to Extension	Transfers the caller to a specific extension.
c. Operator	Transfers the caller to the operator.
d. Exit	Plays the Custom Service exit prompt and disconnects the caller.
e. Previous Menu	Returns the caller to the previous menu.
f. Custom Service	Transfers the caller to another Custom Service and plays the menu.
g. Voice Mail Service	Allows the caller to access Voice Mail Service.
h. Call Transfer Service	Allows the caller to access Automated Attendant Service.
i. Subscriber Service	Allows the caller to access Subscriber Service. Digits received after entering this code are assumed to be the subscriber's mailbox number. If this option is enabled, it is strongly recommended that each subscriber establish a password; this will prevent unauthorized callers from accidentally or intentionally accessing subscribers' mailboxes.
j. Department Dialing	Transfer the caller to the Department Dialing menu.
k. Dial by Name	Requests the caller to enter the first 3 or 4 letters of a last name of the person they wish to reach, then transfers him to the corresponding extension.
l. Repeat Menu	Repeats the Custom Service menu prompts.
m. Main Menu	Returns the caller to the Custom Service top menu.
n. Fax Transfer	Allows the caller to send fax messages to the extension specified as the fax extension.

5.2.4 Recording Menus

After you have finished entering the parameters in each menu, record the menu messages. Menu messages inform the caller of available options and their corresponding keys. For this reason, the prompts must match the programming that has been input.

Note

The Message Manager's mailbox might be 98, 998, 9998, or 99998.

1. **Dial an Extension Number** that is connected to the VPS to access the Message Manager's mailbox (998).
2. When the VPS answers, **Press [#6*998]** to enter the Message Manager's mailbox.
3. **Press [5]** to modify messages.
4. **Press [4]** to change the Custom Service Menu.
5. You will hear:

*Enter the Custom Service prompt number [1] through [100].
To record Custom Service Exit prompt, press [0].*
6. **Enter Custom Service Number** you want to record.
7. You will hear:

*Custom Service number (entered number).
Record menu at the tone...*

Follow the instructions until all Custom Service prompts have been recorded, using the tree that you created as a guide.

5.2.5 Checking Operation

After you have entered and recorded all menus, it is important to try the program yourself to see that all functions perform properly. Dial into the system and try all the choices to see if you are routed correctly. Verify that each menu choice works as it should.

5.2.6 Voice Mail

Voice Mail service is a message-taking service that allows non-subscribers to leave messages to subscribers. This service is often assigned when incoming calls are answered by a live person. This person can then send the caller to the Voice Mail service if desired.

Callers can access Voice Mail service by:

- **Voice Mail Port**—This service can be programmed independently of any or all ports of the VPS. Callers reaching these ports immediately access Voice Mail service.
- **Voice Mail Trunk**—This service can be programmed on a per trunk (CO line) basis. Callers reaching these trunks (CO lines) immediately access Voice Mail service.

- **Service Access Command**—A caller can switch to Voice Mail service by dialing [#6] during a call.
- **Via Custom Service**—This service can be assigned to a keypad digit within a Custom Service. After pressing this key, the caller enters Voice Mail service.

5.2.7 Mailbox Groups

This program allows a message to be delivered to several mailboxes at once. The message activates the message waiting lamps on all of the proprietary telephones. These mailboxes may be assembled into a list called a System Group Distribution List. The Message Manager can record a voice label for each System Group Distribution List (see D6 RECORDING MESSAGES). There are 20 group lists available, and each group list can have up to 20 entries.

To establish a mailbox group:

1. From the System Administration Top Menu, **Type [1-5-1-1-1]** (Program-System Parameter-System Group Assignment-Mailbox Group-Enter).
2. **Assign a List Number** to the Mailbox Group. This number can be from 2-5 digits (same as mailbox numbers). This number must be an unused number. In other words, the number assigned to this group cannot be the same as another System Group Distribution List number or mailbox number. For example, we will use the number 250.

There are 2 ways to use a System Group Distribution List:

Option A:

For inside messages: The System Group Distribution List number can be designed so that any subscriber can press [2] and then enter the list number (which is [250] in this example) to deliver a message. The message will be delivered to all specified mailboxes.

Option B:

For outside messages: The System Group Distribution List number can be designed as a custom greeting for incoming callers. For instance, the greeting might be: *"To leave a message for the parts section, press 3"*. The digit "3" would be assigned to System Group Distribution List number 250 in Custom Service Setting.

Each message waiting lamp will remain on until the message is cleared from the individual station.

5.2.8 Extension Groups

An extension group places several extensions into the same mailbox. These extensions may be assembled into a list called a Extension Group List. The extensions in the group list cannot have a personal mailbox! When a message is left in this mailbox, it lights all of the message waiting lamps of the phones that are in this group list. There are 20 group lists available, and each group list can have up to 20 entries.

When a message is left for the extension group, it will light the message waiting lamps on each phone. The first person that retrieves the call cancels the message waiting lamp on the other

phones. Extension groups work well in areas where the call would not be intended for a specific person (e.g., a Parts Center, Technical Support Group, etc.).

To establish an extension group:

1. From the *System Administration Top Menu*, **Type [1-5-1-2-1]**
(Program-System Parameter-System Group Assignment-Extension Group-Enter).
2. **Enter an Extension Group List Number** that has not been assigned to another mailbox or Extension Group List (this must be a vacant number). **Enter the Extensions** that are to be assigned to this group list.
3. **Enter the Extension Numbers** that are to be assigned to the Extension Group List.
4. **Return** to the *Main Program Menu*.
5. **Type [1-1-1]**
(Program-Mailbox Setting-Enter/Edit).

Assign the Extension Group List Number to a mailbox. If you used the number "700" for an Extension Group List number, assign the number "700" as a new mailbox. You must also enter 700 as an extension.

Messages can be delivered to the new number through normal operation.

5.2.9 Interview Service

The subscriber can leave a series of prerecorded questions (up to 10) for the caller in an Interview Mailbox. As the caller answers questions, answers are recorded in the mailbox. After a caller records the answers, the interview mailbox lights a message waiting lamp. When retrieving the messages, the subscriber only hears the answers to the questions.

There are 2 ways to access an interview mailbox:

- *Assign an interview mailbox to an existing mailbox*
- *Assign a port as an interview mailbox*

To structure an interview mailbox:

1. From the *System Administration Top Menu*, **Type [1-1-1 Mailbox Number-1]**
(Program-Mailbox Setting-Enter/Edit-Mailbox Number-Mailbox Setting).
2. **Enter the Mailbox Number** that is to be assigned to the interview mailbox.
This should be an existing mailbox number for the person who responds to the questions.
3. At "Interview Mailbox Number" parameter, **Enter a Nonexistent Mailbox Number**. This will be the interview mailbox for this subscriber—please make a written note of it for future reference. It will not show up in Mailbox Listing. If, at a later time, you want to delete the interview mailbox, press backspace at "Interview Mailbox Number".
4. **Exit** System Administration Programming.

5. Enter the subscriber's mailbox and **Record the Questions**. **Call** the VPS and **Press [#6*]** then **Dial the Mailbox Number** assigned to the interview mailbox. From the *Main Menu* **Press [6-1]**.
6. Confirm that your questions have been recorded. **Call** the VPS and **Press [#6]** and the **Interview Mailbox Number**. All your questions should be played.

Note

When using the Custom Service setting, 1 digit can be assigned to go to the mailbox of the Interview Service. The mailbox owner's message waiting lamp will go on for normal Voice Mail messages and for message left in the separate interview mailbox.

5.2.10 Automated Attendant

Automated Attendant service answers incoming calls and waits for the caller to input an extension number. It transfers the caller to the appropriate extension.

Callers can access Automated Attendant Service by:

- **Automated Attendant Port**—*This service can be programmed independently of any or all ports of the VPS. Callers reaching these ports access Automated Attendant service.*
- **Service Access Command**—*A caller can switch to Automated Attendant service by dialing [#8] during a call.*
- **Via Custom Service**—*The call transfer service can be assigned to a keypad digit within a Custom Service. After pressing this key, the caller enters Automated Attendant Service.*

Note:

When the VPS calls an extension, the VPS waits for a reply. This waiting time is established by "Call Transfer No Answer Time" in Table 61 (B6.7 Other Parameters).

5.2.11 Department Dialing Service

Callers can access extensions by pressing a key 1 through 9 (one-touch dialing). As a guide for the caller, the Message Manager should record the Department Dialing Menu—for example, *"Thank you for calling. For overseas travel, press 1. For domestic travel, press 2. For group travel, press 3"*.

This service can be assigned to a keypad digit within Custom Service; after pressing this key, the caller will hear the Department Dialing Menu.

5.2.12 Operator Service

This service (when enabled) can be accessed via:

- **Voice Mail**—*Rotary Telephone Service allows rotary callers to reach the General Delivery Mailbox or Operator Service.*
- **Automated Attendant**—*Dial 0 and your call will go to Operator Service.*
- **Custom Service**—*The Operator Service can be assigned to a keypad digit within a Custom Service; after pressing this key, the caller enters Operator Service. Operator Service can also be the destination of "no-DTMF-input".*

Operator Service offers callers many chances to reach a human operator. Operator Service can be structured as a cascade so that if Operator 1 cannot take the call, it goes to Operator 2. If that fails, the call goes to Operator 3. If that fails, the caller can record a message. At each stage, there are other options for busy cases and no-answer cases. Operator Service can be programmed differently for Day, Night, Lunch, or Break Mode. Each operator can be assigned a mailbox for message-taking.

5.3 SETTING PORTS

5.3.1 Port Service Menu

Access the *Port Service Menu* through the following sequence:

System Administration Top Menu:

Enter The Number: = **1** (Program)
 Enter The Number: = **3** (Port/Trunk Service)
 Enter The Number: = **1** (Port Service)

Screen output:

```
Program - Port/Trunk Service - Port Service
Enter the Port Number (1-2) :=
```

From Program-Port/Trunk Service-Port Service Menu:

Enter the data using the table below as a guide.

Note

In the table below, the sub-parameter "Prompt for Rotary Callers" is underlined. This sub-parameter can be assigned only when "Incoming Call Service Prompt" is set to "Selective".

Table 22

Description	Value Range (Default)	Description/Function
Incoming Call Service	1. Voice Mail 2. Auto. Attn. 3. Interview 4. Custom (Auto. Attn.)	Specifies one of 4 incoming call services. [Notes] <ul style="list-style-type: none"> When you specify the Interview Service, one of Subscriber's Interview mailbox numbers should also be specified. When you specify the Custom Service, one of 100 (1-100) Custom Service numbers should also be specified.

Table 22

Description	Value Range (Default)	Description/Function
Incoming Call Service Prompt	1. System 2. User 1 3. User 2 4. Selective (User 1)	Specifies the language of voice prompts to be played on this port. When set to "Selective", the caller can select the language of his choice, provided the Message Manager has recorded the Multilingual Selection Menu and the System Administrator has specified Prompt Selection Number in "System/User 1/User 2 Prompt Selection Number" in Table 58 in B6.5 Prompt Setting. [Note] <ul style="list-style-type: none"> If "Selective" is specified, you will need to select a prompt available for rotary callers. See "Prompt for Rotary Callers" below.
<u>Prompt for Rotary Callers</u>	1. System 2. User 1 3. User 2 (System)	Specifies which language (System/User 1/User 2) a rotary caller or an External Delivery Message receiver hears when he cannot enter any digit (Prompt Selection Number) after the Multilingual Selection Menu has been played.
Delayed Answer Time	0-60 s (0)	Specifies whether the port answers immediately (0) or in delay (1-60 s).

5.4 AUTOMATED ATTENDANT PARAMETERS

Automated Attendant parameters include: Department Dialing, Operator Parameters, and Alternate Extension.

If the VPS needs a special transfer procedure for an extension (such as modem extension), alternate extension should be assigned (see "Alternate Extension Assignment" in B5.1 Automated Attendant Parameters).

5.4.1 Automated Attendant Menu

Access the *Automated Attendant Menu* through the following sequence:

System Administration Top Menu:

Enter The Number: = **1** (Program)
 Enter The Number: = **4** (Service Setting)
 Enter The Number: = **1** (Automated Attendant)

Program - Service Setting - Auto. Attn. Setting Menu

1. Department Dialing
2. Operator's Parameters
3. Alternate Extension

5.4.2 Department Dialing

Department Dialing numbers (1-9) represent department extensions; the VPS will provide these numbers to the caller in the initial list of prompts.

Return to Program-Service Setting-Auto. Attn. Setting Menu:

Enter The Number : = 1

Program - Service Setting - Auto. Attn. Setting - Department Dialing Menu

1. Department Dialing No.1 [] := 102
2. Department Dialing No.2 [] := 104
3. Department Dialing No.3 [] := 115
4. Department Dialing No.4 [] := 136
5. Department Dialing No.5 [] := 107
6. Department Dialing No.6 [] := 108
7. Department Dialing No.7 [] := 109
8. Department Dialing No.8 [] := 110
9. Department Dialing No.9 [] := 111

5.4.3 Operator's Parameters

If you enable operator service, you must set the following parameters: Operator's Extension and Mailbox Number, Coverage Modes, and Message Repeat Cycle.

Operator 1:

The default is set at "0" which coincides with the operator of the PBX. When a caller tries to leave a message to the Operator 1, the message will automatically go to the General Delivery Mailbox (GDM) by default.

Operators 2 and 3:

For KX-TD816, KX-TD1232 and KX-TA1232, Operators 2 and 3 can be assigned to a floating number that is assigned to a ring group.

Return to Program-Service Setting-Auto. Attn. Setting Menu:

Enter The Number : = 2

Program - Service Setting - Auto. Attn. Setting - Operator's Parameters Menu

1. Day Mode
2. Night Mode
3. Lunch Mode
4. Break Mode

SELECT ITEM AND PRESS KEY

1. Operator 1
2. Operator 2
3. Operator 3

SELECT ITEM AND PRESS KEY

Enter the data using the table below as a guide. The table below is for Operator 1 as an example. Please refer to it for Operators 2 and 3.

Table 23

Description	Value Range (Default)	Description/Function
Operator Service	1. Disable 2. Enable (Enable)	Enables or disables the Operator Service feature. [Note] <ul style="list-style-type: none"> • All non-touchtone input calls in Automated Attendant Service will be transferred to the General Delivery Mailbox when the Operator Service is disabled.

Table 23

Description	Value Range (Default)	Description/Function
Operator's Extension	1-5 Digits (0)	<p>Specifies the extension number for Operator 1.</p> <p>[Notes]</p> <ul style="list-style-type: none"> The default setting (0) cannot be used with the Message Waiting Notification—Lamp feature and the Remote Call Forwarding Set feature. When using these features, you must assign the extension number that is included in the Extension Numbering Plan. The extension number must not be assigned anywhere else (in particular, the extension must not have a mailbox). Otherwise, you will get an error message.
Operator's Mailbox No.	2-5 Digits (998)	<p>Callers to Operator 1 are prompted to leave a message in this mailbox depending upon how the Busy Coverage or No Answer Coverage modes are set.</p>
Operator No Answer Time	10-60 s (30)	<p>When a call to Operator 1, 2, or 3 is not answered within the time set, the VPS will offer other options as defined by the "No Answer Coverage Mode".</p> <p>[Notes]</p> <ul style="list-style-type: none"> This timer applies to Operator 1, 2, and 3. If more than 1 operator is assigned, we recommend to reduce the time on the "Operator No Answer Time" to 15 s.
Busy Coverage Mode	<ol style="list-style-type: none"> Hold No Answer Coverage Call Waiting Disconnect Message <p>(Hold)</p>	<p>Specifies how to handle calls when the Operator 1 extension is busy.</p> <ol style="list-style-type: none"> Hold—Automatically places the caller on hold and the Operator 1 extension is called again. No Answer Coverage—Offers the option specified by the No Answer Coverage Mode to the caller. Call Waiting—Signals the Operator 1 when another call is waiting using the Call Waiting feature of the PBX. Disconnect Message—Disconnects the caller after playing "<i>Thank you for calling.</i>"

Table 23

Description	Value Range (Default)	Description/Function
No Answer Coverage Mode	1. Caller Select 2. Leave Message 3. Disconnect Message 4. Next Operator (Caller Select)	Specifies how to handle Operator 1 calls when not answered within the time period set by the "Operator No Answer Time" mode. 1. Caller Select*—Allows the caller to leave a message or call another extension. 2. Leave Message—Instructs the caller to leave a message in Operator 1's mailbox. 3. Disconnect Message—Disconnects the caller after playing "Thank you for calling." 4. Next Operator—Transfers the caller to Operator 2.
Message Repeat Cycle	1-3 Times (3)	Specifies the number of times that the VPS will play the Automated Attendant top menu.

*: **Note**

In the following cases, the caller cannot "select". He is directed to Operator 1's mailbox when he is transferred to the operator but the operator does not answer:

- 1. No input to Automated Attendant.**
- 2. No input to Custom Service menu when "No DTMF Input Operation" is set to "C. Operator" in Table 48 in B5.2 Custom Service.**
- 3. No input to Voice Mail service when "Rotary Telephone Call Coverage" is set to "Operator Extension" in Table 65 in B6.7 Other Parameters.**

5.5 SETTING MAILBOXES

5.5.1 Mailbox Setting Menu

Access the *Mailbox Setting Menu* through the following sequence:

System Administration Top Menu:

Enter The Number: = **1** (Program)

Enter The Number: = **1** (Mailbox Setting)

Program - Mailbox Setting Menu

1. Enter/Edit
2. Delete
3. Password Reset
4. Mailbox Listing

5.5.2 Entering a Mailbox

From Mailbox Setting Menu:

Enter The Number : = **1**

Enter the Mailbox number: =

Program - Mailbox Setting - Enter/Edit Menu

1. Mailbox Setting
2. Notification Setting
3. Remote Call FWD to CO

Enter The Number : = **1**

Enter the data using the following table as a guide.

Table 24

Description	Value Range (Default)	Description/Function
The Extension of the Owner	2-5 Digits (None)	Sets the extension to be used in conjunction with the mailbox. Any valid number can be assigned.
Owner First Name	Up to 16 alphabetic characters (None)	The Dial by Name feature uses the last name. Both will be printed on mailbox report.
Owner Last Name		
Class of Service No.	COS No.1-62 (1)	Defines a set of services available to each subscriber. The Class of Services 63 and 64 are fixed to the Message and System Managers. Most subscribers can be placed in the same COS. Anyone who needs unclaimed messages forwarded to a cell phone, beeper or another mailbox would need to be in a separate COS.

Table 24

Description	Value Range (Default)	Description/Function
Covering Extension	2-5 Digits (None)	Specifies where a caller will be transferred when Covering Extension is dialed or set under Incomplete Call Handling.
Interview Mailbox Number	2-5 Digits (None)	Used to permit mailbox owner to have an interview mailbox. Must be an unused mailbox.
All Calls Transfer to Mailbox	1. Yes 2. No (No)	If set to Yes, calls coming to the extension through Automated Attendant go directly to the mailbox without ringing the extension. (Message Waiting Lamp will not be turned on.)

From Mailbox Setting Menu:

Enter The Number : = **1**
 Enter the Mailbox number: =

Program - Mailbox Setting - Enter/Edit Menu

1. Mailbox Setting
2. Notification Setting
3. Remote Call FWD to CO

Enter The Number : = **2**

Program - Mailbox Setting - Enter/Edit - Notification Setting

1. 1st Device
2. 2nd Device
3. 3rd Device

Enter The Number : =

Enter the data using the following table as a guide.

Table 25

Parameter	Value Range (Default)	Description/Function
Dial Number	Up to 32 digits consisting of 1-9, 0, *, # P, T, M, X (None)	<p>Assigns a telephone or beeper number to Device 1, 2, or 3. The subscriber can also specify the dial number from his telephone.</p> <p>P: Pause T: Dial Tone Detection M: Dial Mode Switching Code (Touchtone to Pulse, or Pulse to Touchtone) X: Callback Number Entry Code 1-9, 0, *, #: Dial Codes</p> <p>Note: The callback number entry code "X" must be included in the number to be called if the Beeper Callback No. Entry Mode is enabled through COS and "Type of Device" is set to "Beeper". The proper number of "Pauses" must be inserted before the callback entry code.</p> <p>Important Note: When the VPS calls to an outside line via a PRI (ISDN Primary Rate Access Interface) card of a Panasonic PBX, please be sure to add "#" after the telephone number (1112223333 in the example here): <i>Example:</i> 9P1112223333#PP123PP456PPX# Please contact your System Administrator for more explanation.</p>
Type of Device	1. Telephone 2. Beeper (Telephone)	Specifies the device to receive notification. This is automatically set to "Beeper" when "X" is used in the Dial Number (above). The subscriber can also specify the type of device from his telephone.
Use Mode	1. Not Use 2. Continuously 3. Scheduled (Continuously)	<p>Specifies how Device 1, 2, or 3 is to be used. The subscriber can also specify the use mode from his telephone.</p> <p>1. Not Use—Device 1, 2, or 3 is not used for a notification call. 2. Continuously—Device 1, 2, or 3 is called whenever a message is recorded in the mailbox. 3. Scheduled—Device 1, 2, or 3 is called on a schedule basis when a message has been left in the mailbox.</p>

Table 25

Parameter	Value Range (Default)	Description/Function
No. of Retries	0-9 times (0)	Specifies the number of times that a notification call to Device 1, 2, or 3 should be attempted after a busy or no answer condition is received.
Busy Delay Time	0-120 min (3)	Specifies the time (in minutes) the VPS must wait after a busy condition is received before making another notification call to Device 1, 2, or 3.
No Answer Delay Time	60-120 min (60)	Specifies the time (in minutes) the VPS must wait after a no-answer condition is received before making another notification call to Device 1, 2, or 3.
Time Frame 1, 2 MON: TUE: WED: THU: FRI: SAT: SUN:	1-12: h 00-59: min AM/PM: a.m./p.m. *: All Day Space: No Use (No Use)	Specifies the daily schedule for the Message Waiting Notification service for 1 week for this device. Note: These parameters are active only when "Use Mode" is set to "Scheduled".

From Mailbox Setting Menu:

Enter The Number : = **1**
Enter the Mailbox number: =

Program - Mailbox Setting - Enter/Edit Menu

1. Mailbox Setting
2. Notification Setting
3. Remote Call FWD to CO

Enter The Number : = **3**

Program - Mailbox Setting - Enter/Edit - Remote Call FWD to CO

1. Telephone No.1 [] (0-9,*)
Enter the telephone No.1 : =
2. Telephone No.2 [] (0-9,*)
Enter the telephone No.2 : =

Enter the data using the following table as a guide.

Table 26

Parameter	Value Range (Default)	Description/Function
Telephone Number 1, 2	Up to 16 digits (With the KX-TD816/TD1232/TA1232) (None)	Specifies the telephone number to which the callers are forwarded when Remote Call Forwarding is set to a CO line. The telephone number can contain the digits "0-9" and "*". Note: This feature is available with DPT Integration only.

5.5.3 Deleting a Mailbox

From Mailbox Setting Menu:

Enter The Number : = 2

Program - Mailbox Setting - Delete

Enter the Mailbox Number : =

Are you sure? (Y/ N) : =

5.5.4 Password Reset

To reset a subscriber's password, go to the Password Reset Menu. "Enter the Mailbox Number" appears on the screen. Enter the mailbox number you wish to reset. "Enter the Mailbox Number" appears again. Enter a new number, if you wish to reset more than one password.

From Mailbox Setting Menu:

Enter The Number : = 3

Program - Mailbox Setting - Password Reset

Enter the Mailbox Number : =

Enter the Mailbox Number : =

5.5.5 Mailbox Listing

This listing is a report of mailbox number assignments.

From Mailbox Setting Menu:

Enter The Number : = 4

Program - Mailbox Setting - Mailbox Listing

1: 101	2: 103	3: ---	4: ---	5: ---
6: ---	7: ---	8: ---	9: ---	10: ---
11: ---	12: ---	13: ---	14: ---	15: ---
16: ---	17: ---	18: ---	19: ---	20: ---
21: ---	22: ---	23: ---	24: ---	25: ---
26: ---	27: ---	28: ---	29: ---	30: ---

System Manager's Mailbox No. :**999**

Message Manager's Mailbox No. :**998**

Note

Depending on the PBX extension numbering, the mailbox numbers might be 2- to 5-digit long.

5.6 TRAINING THE SUBSCRIBER

The System Administrator should explain the basic functions of the VPS to all the subscribers. He should explain which service (Voice Mail service, Automated Attendant service, Interview Service, or a Custom service) will play during the day, and what services will play during night, lunch, and breaks. He should explain that outside callers are called "non-subscribers" because they do not have mailboxes. VPS guidance prompts will assist non-subscribers in reaching the extension or mailbox they need. He should explain the responsibilities of the System Administrator, the Message Manager, and the System Manager—and how each can be contacted (phone number and/or mailbox number).

The System Administrator should also explain the special privileges of VPS subscribers. Subscribers can call from any touchtone telephone in the world and get their messages. To check messages (or change mailbox parameters) from an outside telephone, do the following:

As soon as the VPS plays a guidance message, **Press** code [# 6 *] and then **the mailbox number**. For example, a subscriber who has extension 115 and mailbox 115 would press code [# 6 * 115]. If the subscriber has a password enabled, the password must be entered.

If the subscriber forgets his password, he should contact either the System Administrator or the System Manager. Either one can clear the password so that the subscriber can establish a new password.

Explain the purpose of the General Delivery Mailbox. The Message Manager will periodically check it, and forward the contents to the appropriate subscriber.

Explain the purpose of the System Group Distribution Lists. They can be created by the System Administrator to facilitate the distribution of messages to several subscribers. In particular, senior staff members ought to know how to take advantage of System Group Distribution Lists. Twenty lists can be created, with 20 mailboxes in each list.

Finally, if Custom Service menus are used, subscribers should be encouraged to listen to these menus often and make suggestions for improvement. Custom service is a very powerful feature of the Panasonic VPS. Make the most out of this feature.

Section 6
FINAL SETUP

6.1 MESSAGE MANAGER'S MAILBOX (Mailbox 998)

The Message Manager is responsible for recording and updating a wide variety of system messages. Please refer to D6 RECORDING MESSAGES to see the full array of recording tasks. Follow the instructions below to record Custom Service prompts and user prompts.

Note:

The Message Manager's mailbox might be 98, 998, 9998, or 99998.

6.1.1 Accessing the Message Manager's Mailbox

1. Enter an **Extension Number** that is connected to Voice Mail.

You will hear the initial prompt:

Good morning/Good afternoon/Good evening.
Welcome to the Voice Processing System...

2. Press [# 6*9 9 8] to access the Message Manager's mailbox.

You will hear the following prompt if mailbox 998 has a password set:

Enter your password, followed by a pound sign.

3. Enter the **Message Manager's Password** (if programmed). Otherwise, you will hear the *Main Menu of Message Manager's Service*.

6.1.2 Main Menu of Message Manager's Service

You have (number) new message(s).
To transfer General Delivery Mailbox messages, press [1].
To set up message waiting notification, press [2].
To customize your mailbox, press [3].
To set the clock, press [4].
To modify message, press [5].
To set station call forwarding, press [6].
To end this call, press [*].

6.1.3 Custom Service Greetings (Enter #6*998,5,4)

1. Access the *Main Menu of Message Manager's Service*.
2. Press [5] to modify messages.
3. Press [4] to change the *Custom Service Menu*.
4. Continue following voice prompts through appropriate menus. Prompts lead you through the choices and recording process.

Example: Custom Service Greeting: "Thank you for calling ABC Company. If you know your party's extension, you may dial it at any time during this message".

Note

This prompt should match the prompt that is selected for each port. The recording will be played directly after the call is received.

6.1.4 Customizing User Prompts (Enter #6*998,5,6)

The customer may want to enter user prompts in place of the factory-provided system prompts. To change the user prompts:

1. Access the *Main Menu of Message Manager's Service*.
2. Press [5] to modify messages.
3. Press [6] to modify the User Prompts.
4. Press [1] to change User Prompt 1, or Press [2] to change User Prompt 2.
5. Press [1] to change specified prompts, or Press [2] to change all prompts.
6. Enter the **Prompt Number** you want to change.
7. Continue following voice prompts through appropriate menus. Prompts lead you through the choices and recording process.

Note

Prompt 585: The system prompt is "This is the General Delivery Mailbox". You can record User Prompt 1 or User Prompt 2 as, "Thank you for calling ABC company. We are currently closed, however, if you leave your name and phone number, we will return your call as quickly as possible".

6.2 SETTING UP MAILBOXES

The following steps complete the basic installation of the VPS. For each mailbox on the system, a No Answer, Busy, and After Hours Greetings should be recorded, as well as the Owner's Name and Password. Please follow the steps below to set up the mailboxes accordingly.

6.2.1 Recording Personal Greetings

- The No Answer Greeting plays whenever the caller enters your mailbox during business hours.
- The Busy Greeting plays when the caller is told your line is busy and then selects to leave a message in your mailbox.
- The After Hours Greeting plays whenever the caller enters your mailbox when the VPS is in the Night Mode.

1. **Dial** the **Extension Number** of the VPS.
2. When the VPS answers, **Press [#6*]** and **Dial** the **Number** of the mailbox for which you wish to record Personal Greetings.
3. **Enter** your **Password** (if programmed), then **Press [#]**.
You are now inside the mailbox.
4. **Press [5]** for Mailbox Management.
5. **Press [1]** to change the Personal Greetings.
6. **Press [1]** again to change the No Answer Greeting.
7. The system will then say: *"No Answer Greeting is not recorded. Record greeting at the tone"*.
8. **State** your **Greeting** at the tone.

Example: "Hi this is Tom. I am away from my desk right now but please leave a message at the tone and I will return your call as soon as possible".

9. **Press [1]** when finished.
The system gives the options of reviewing, accepting, or erasing the message.
10. **Press [1]** to review the greeting.
11. **Press [2]** to accept the greeting.
12. The system will then play the menu for changing the No Answer Greeting, Busy Signal Greeting and the After Hours Greeting. Record the Busy Signal Greeting as you did for the No Answer Greeting.
13. Continue on to the After Hours Greeting and hang up when finished.

6.2.2 Recording the Owner's Name

1. **Dial** the **Extension Number** of the VPS.
2. When the VPS answers, **Press [#6*]** and **Dial** the **Number** of the mailbox to which you wish to record the Owner's Name.
3. **Enter** your **Password** (if programmed), then **Press [#]**.
You are now inside the mailbox.
4. **Press [5]** for Mailbox Management.
5. **Press [3]** to change the Owner's Name.
6. The system will say: *"Owner's name is not recorded. Record owner's name at the tone"*.
7. **State** the **Owner's First and Last Name** at the tone.
8. **Press [1]** when finished.
The VPS tells you the customer's name.
9. **Press [2]** to accept.

TEST THE SYSTEM

Before backing up the system, call each extension to see that each port functions as it should. Check for proper greetings and call transfers.

6.3 BACKING UP THE SYSTEM

1. Choose the **Utility Command**. Type [SAVE], then Press **ENTER**. See screen output below.

From System Administration Top Menu:

Enter The Number: = 3 (Utility Command)

```
$ SAVE
VPS Flash Memory Data Save ( VPS -> PC : Xmodem )
1: Program
2: Parameters
3: System Prompts
4: User Prompts-1
5: User Prompts-2
6: Custom Service Menus
7: Personal Greetings
Select No. : = 2
```

2. To start, Press [2] and then **ENTER**.
3. Press **RETURN** or **ENTER**.

Following steps are for HyperTerminal as an example.

4. Select Recieve File from the Transfer Menu.
5. Specify a **folder** where data is to be saved (if necessary, use "Browse").
6. Select *Xmodem* as the protocol to save data.
7. Click "Recieve".
8. Enter desired **filename** and click "OK".

The file transfer screen appears and shows download progress. Download time will vary depending on the communication speed and file sizes.

"SAVE Completed" will appear on the screen when the file has been saved. Continue saving the other items as needed. It is not necessary to save the "Program" because it is resident on the flash memory (Master) and cannot be altered. We do recommend all other data be saved including User Prompt 1 and User Prompt 2 (if they have been recorded).

Notes

Recorded caller names for the Caller Name Announcement (System/Personal) cannot be saved by the above procedure, only Caller ID numbers can be saved. When the saved

Caller ID numbers are loaded using LOAD command, the following things should be done:

- *For System Caller Name Announcement, the Message Manager rerecords caller names (see "Recording System Caller Names" in D6 RECORDING MESSAGES).*
- *For Personal Caller Name Announcement, subscribers rerecord caller names (see 4.12 Personal Caller Name Announcement in the Subscriber's Guide).*

User Prompt files are very large and can take 1 h to save. Store saved files in a safe area.

Section 7

***SYSTEM MAINTENANCE AND
TROUBLESHOOTING***

7.1 INITIALIZING THE SYSTEM

Initializing the system clears all voice data except user prompts and returns all system parameters to their default settings. Throughout this section, menu selections are indicated as "**System Administration Top Menu-(Selection Number)**". This means that the System Administration Top Menu must first be accessed. On the first menu displayed, make the menu selection corresponding to the first menu displayed. Repeat this process for each subsequent menu when additional selection numbers are listed.

To initialize the system, follow the menu path as shown:

System Administration Top Menu-4

1. Go to the System Administration Top Menu

```
1 : Program
2 : System Reports
3 : Utility Command
4 : System Reset/Clear
5 :Quick Setup (VT100 Mode Only)
Enter the number: =
```

2. Type [4] for System Initialization.

```
System Reset/Clear Menu
1. Mailbox No. Length [3]
2. System Manager's Mailbox No. [999]
3. Message Manager's Mailbox No. [998]

Will you change the settings ? (Y/N): =
```

Note

Depending on the PBX extension numbering, the "Mailbox No. Length" might be 2 to 5.

3. Type [Y] (this places the VPS in the off-line mode).

```
System Reset/Clear Menu
1. Mailbox No. Length [3] (2 - 5) : =
2. System Manager's Mailbox No. [999] : =
3. Message Manager's Mailbox No. [998] : =

Are these parameters acceptable ? (Y/N) : =
```

4. Type [Y] to start the system resetting.

```
System Initializing
```

```
•  
•  
•
```

5. When system initializing is complete, the following display will appear:

```
** ON LINE MODE **
```

```
>
```

Note

The execution time for System Reset/Clear may differ each time it is performed because of system capacity and system programs.

Generally, initialization will take about 2 min to accomplish.

7.2 UTILITY COMMANDS

In the Utility Command Mode, the System Administrator can access the functions described below by entering the appropriate command at the "\$" prompt, and **Pressing RETURN**.

To select the Utility Commands Menu, follow the menu path as shown:

System Administration Top Menu-3

Utility Command (Type 'HELP' for command list.)
\$

Table 27

OFLN:	Sets the system to off-line mode
ONLN:	Sets the system to on-line mode
PASS:	Sets the System Administrator's password
TIME:	Sets the system clock, date, and time
PSET:	Specifies the reports printing time
ELOG:	Displays device error log
SAVE:	Stores a backup of the program or data in the flash memory
LOAD:	Restores a backup of the program or data to the VPS
GPRN:	Displays all of the VPS parameters
VERS:	Displays the version of the program
CREP:	Displays the keypad assignments, message recording status and the tree-structure of a Custom service
CCLR:	Clears a Custom service menu access count
MWL:	Specifies the number of times the VPS attempts to turn on the message waiting lamp on the extensions
MRL:	Sets the minimum recording length of a message
MPLT:	Displays the user prompt recording status
HELP:	Displays brief instructions and a list of Utility Commands
QSET:	Set up your VPS roughly so that you can use it quickly
LMON:	Line Monitor
PUTD:	Displays Touchtone Information
WCID:	Wait for Caller ID

7.2.1 Off-line Set (OFLN)

Use the OFLN command to turn off the VPS Call Progression Mode. Set the VPS to Off-Line Mode before deleting a mailbox, since this operation involves the updating of a large number of related parameters.

Type OFLN, then **Press RETURN**. If no VPS ports are in use, the VPS will immediately suspend the Call Progression Mode.

```
$ OFLN
** OFF LINE MODE **
```

If any VPS port is in use, the VPS will display the following warning:

```
*** Now line is used!! *** <WAIT>
```

The following message indicates that the VPS is in the Off-Line Mode.

```
** OFF LINE MODE **
```

7.2.2 On-line Set (ONLN)

Use the ONLN command to place the VPS in the Call Progression Mode.

Type ONLN, then **Press RETURN**.

```
$ ONLN
** ON LINE MODE **
```

7.2.3 Set Password (PASS)

Use the PASS command to create, change and clear system passwords. Valid passwords are created using up to 10 characters; any alphanumeric character, [(space)], [.] and [_] can be used.

IMPORTANT

- *We strongly recommend that you set the password to 10 characters for maximum protection against hackers.*
- *Do not carelessly reveal the password to other persons.*
- *Please change the password periodically.*

1. Type PASS, then Press RETURN.

\$ PASS 1: Administrator Password 2: System Reset/Clear Password :=
--

2. To create a password or change an existing password, **Go to Step 3.**
To clear a password, **Go to Step 4.**

3. To create a password or change an existing password:

a) Type [1] or [2]

Maximum 10 characters NEW PASSWORD : =

Note

When you press [2] to change the System Reset/Clear password, you should type the current (OLD) password before entering a new one.

b) Type the password.

VERIFICATION: =

c) Type the password again for verification.

4. To clear a password:

a) Type [1] or [2].

Maximum 10 characters NEW PASSWORD : =

b) Press ENTER. Do not type a password on this screen.

VERIFICATION : =

c) Press ENTER. Do not type a password on this screen.

Note

The password entered on the screen will not appear. The VPS does not distinguish the capital letter from the small letter.

7.2.4 Set Time (TIME)

Use the TIME command to set the system date and time. A number of system functions require that the system time and date be set correctly. These functions include message waiting notification, external message delivery, call-retries-after initial-failure-to-connect, and automatic deletion of messages.

Time Synchronization: If you have DPT Integration between the VPS and your PBX (latest software version), the date and time are automatically sent from the PBX to the VPS whenever the PBX sets the date and time. Also, this transfer occurs whenever DPT Integration is established.

1. Type TIME, then Press RETURN.

```
$ TIME
Current time is 12:34, PM
Enter new time (HH:MM, AM/PM) :=
```

2. Type the current time.

```
Current date is MON JAN-1-2001
Enter new date (MM-DD-YY) :=
```

3. Type the current date. For the year, type the last 2 digits.**Note**

Enter the exact time and date. This command cannot be used when either the System or the Message Manager is accessing the time setting feature.

7.2.5 Print Reports at Specified Time (PSET)

Use the PSET command to issue system usage reports (Flash Memory Usage Report, Port Usage Report, Call Account Report) at a specified time each day. A printer or data terminal must be connected to the VPS at the RS-232C port for the reports to be printed or displayed.

1. Type PSET, then Press RETURN.

```
$ PSET
Report Print Out Service [ Disable ]
1 : Enable 2: Disable :=
```

2. Type [1] to enable this function or Type [2] to disable it.

```
Enter The Print Out Time (HH:MM, AM/PM) :=
```

3. Type the time to print the reports.**Note**

The reports will be displayed only if the system is in the mode where you see the following prompt:

```
>
```

7.2.6 Error Log Display (ELOG)

Use the ELOG command to diagnose VPS problems. Selection of this command will display an error log.

COM. Communication error between CPU and DSP
 DATA Process error of voice data
 MEM. Memory error
 PRG. Program error in CPU card
 R/W Read/Write error of Flash Memory

Type **ELOG**, then Press **RETURN**.

\$ ELOG	DEVICE	ERROR	TIME
	1. CPU	MEM-GET	JUL-14 2:00 PM
	2. CLOCK		JUL-14 2:00 PM
	3. FLASH MEMORY	DATA R/W (xx:yyyy)	JUL-14 2:00 PM
	4. DSP*	SCAN	JUL-14 2:00 PM
	5. DSP*	FIFO	JUL-14 2:00 PM
	6. CPU	APPLICATION (x)	JUL-14 2:00 PM

* = Port number (1-2)

Note

The following tables display and explain the errors that the system can identify.

Table 28 Device Error Log Indications

	Indication	Meaning
CPU	MEM-GET	CPU card software memory acquisition error. CPU card is short of memory temporarily because of too much traffic.
CLOCK		Clock access error. Clock IC is out of order. Check the hardware.
FLASH MEMORY	DATA R/W (xx:yyyy)	Flash Memory access error. If there is a sector that often causes errors, check the flash memory. xx : IDE error code yyyy : read/write error sector number
DSP*	SCAN	DSP-SCAN error. DSP is out of order. Check the hardware.
DSP*	FIFO	DSP/FIFO error. During the system is handling calls, there is something wrong with DSP and FIFO memory temporarily.
CPU	APPLICATION (x)	Application error. While the system is handling calls, temporary application error occurs. x: port number

* = Port number (1-2)

Examples of a terminal display when errors are generated:

Table 29 Error Indications at System Startup

Indication	Meaning
ROM ERROR: Sum Error!!	ROM checksum error.
FLASH MEMORY ERROR: Initialize Error!!	Flash Memory initialization error.
FLASH MEMORY ERROR: No System!!	No system Flash Memory present.
FLASH MEMORY ERROR: Program Load Error!!	Program could not be loaded from system Flash Memory.
FLASH MEMORY ERROR: Program Sum Error!!	Checksum error in program loaded from system Flash Memory.
FLASH MEMORY ERROR: System Data Error!!	Error Loading of administrator data from system Flash Memory.
SYSTEM ERROR: 1	Administrator data error.
SYSTEM ERROR: 2	Error loading of report data.
SYSTEM ERROR: 3	Clock error.
SYSTEM ERROR: 4	Mailbox data error.
SYSTEM ERROR: 5	Message data error (1).
SYSTEM ERROR: 6	Message data error (2).
SYSTEM ERROR: 7	Error loading of control data.
SYSTEM ERROR: 8	Error loading of voice prompt data.
SYSTEM ERROR: 9	Error loading of MWL control data.
SYSTEM ERROR: 10	Error loading of flash memory identify data.
SYSTEM ERROR: 11	Error writing of VBI chain data.
SYSTEM ERROR: 12	Error writing of BLK chain data.
SYSTEM ERROR: 13	Error loading of user prompt modify data.
SYSTEM ERROR: 14	Error loading of Class of Service data.
No CO lines are active!!	No Port cards present.
COs are all disabled!!	All Ports are malfunctioning.
APT(DPT) Interface Connection is not Established.	Ports are malfunctioning for APT(DPT) Integration because telephone lines are disconnected or Integration with PBX is not set to APT(DPT) integration mode.

Table 30 Error and Warning Indications During System Operation

Indication	Meaning
FLASH MEMORY STORAGE SPACE IS NOW EXCEEDING 80%...	80 % or more of the Flash Memory voice message save area is used.
ASCII TERMINAL program Load Error	Error loading of ASCII terminal control program.

7.2.7 Saving the System Data to the Backup Device (SAVE)

All system programming data and voice prompts can be saved in separate data files. To save this data, connect a data terminal to the RS-232C port of the VPS. Save the files individually. Execute the SAVE command for each data file. It will require several minutes to execute this command for all the data selected. When performing this operation, always wait until the process completion indication appears.

WARNING

Never save (back-up) and upload the "Program" without Panasonic Technical support.

The memory required to save each data component is indicated below.

- | |
|---|
| <ol style="list-style-type: none"> 1. Program—approximately 1 Mbytes (See Warning above) 2. Parameters—approximately 0.4 Mbyte (System Configuration) 3. System Prompts—approximately 5 Mbytes (Do not save—prompts are saved as defaults in the flash memory) |
|---|

Saving items 4-7 below will depend upon the length of the recorded messages.

4. User Prompts-1
5. User Prompts-2
6. Custom Service Menus (Custom service recordings)
7. Personal Greetings (Subscriber greetings)

1. Type SAVE, then Press RETURN.

```
$ SAVE
VPS Flash Memory Data Save (VPS -> PC : Xmodem)
1: Program
2: Parameters
3: System Prompts
4. User Prompts-1
5. User Prompts-2
6. Custom Service Menus
7. Personal Greetings
Select No. :=
```

2. Select item to be backed up, then Press RETURN. The size of the file will be displayed.

```
To start press 'RETURN'
```

3. Press RETURN.

```
----- SAVE Start!!
```

4. Perform a Standard File Transfer. Set the data terminal to the receiving (Answer) mode (Xmodem) and specify the backup filename. The specified data will be transmitted to the data terminal.**Notes**

- *The data terminal that you use must be equipped with communications software that supports the Xmodem file transfer protocol. The command can be canceled by Typing [^] before entering the receiving mode. Once the receiving mode has been selected, use the cancel command of the communication software being used.*
- *If your data terminal supports a high speed, it is recommended that you SAVE at the maximum speed of 38400 bps. First, change the RS-232C setting of the VPS (see B7.1 RS-232C Parameters). Next, change the RS-232C setting of your data terminal to the same speed.*

7.2.8 Loading New or Saved Data to the VPS (LOAD)

Use the LOAD command to install new data or to restore saved data to the VPS. Execute this command for each data file.

When performing this operation, always wait until the process completion indication appears before proceeding.

1. Type **LOAD**, then Press **RETURN**.

```
$ LOAD
VPS Flash Memory Data Load (PC -> VPS : Xmodem)
1: Program
2: Parameters
3: System Prompts
4. User Prompts-1
5. User Prompts-2
6. Custom Service Menus
7. Personal Greetings
Select No.:=
```

2. Select the item to be restored to the flash memory, then Press **RETURN**.

```
To start press 'RETURN'
```

3. Press **RETURN**.

```
----- Load Start!!
```

When "CCC" appears, the VPS is ready for loading.

4. Set the data terminal to the sending (Call) mode (Xmodem). Then enter the backup filename. Press **ENTER**. The backup data will be restored to the flash memory.
5. When the load to the VPS has been completed, power-off and restart the VPS.

Notes

- *The data terminal that you use must be equipped with communications software that supports the Xmodem file transfer protocol. The command can be canceled by Typing [^] before entering the sending mode. Once the sending mode has been selected, use the cancel command of the communication software being used.*
- *If your data terminal supports a high speed, it is recommended that you LOAD at the maximum speed of 38400 bps. First, change the RS-232C setting of the VPS (see B7.1 RS-232C Parameters). Next, change the RS-232C setting of your data terminal to the same speed.*

7.2.9 Print All of the VPS Parameters (GPRN)

Use the GRPN command to print all VPS parameter settings (output to screen). Use Ctrl-C at any time to stop printing.

Type **GPRN**, then Press **RETURN**.

```

$ GPRN
  0: All Parameters
  1: Mailbox Setting
  2: Class of Service Setting
  3: Port/Trunk Service Setting
  4: Service Setting - Auto Attn. Setting
  5: Service Setting - Custom Service Setting
  6: Service Setting - Caller ID Call Routing
  7: System Parameter Setting - System Group Assignment
  8: System Parameter Setting - Time Service, Holiday, Daylight Saving Time
  9: System Parameter Setting - Prompt Setting
 10: System Parameter Setting - System Caller Name Announcement
 11: System Parameter Setting - Others
 12: Hardware Setting
 13: System Reset Clear Parameter

Please select : =

```

Note

This command is only valid when in the ASCII TERMINAL mode.

7.2.10 Program Version Display (VERS)

Use the VERS command to display the version numbers of the flash memory and main ROM.

Type **VERS**, then Press **RETURN**.

```

$ VERS
V.P.S. PROGRAM VERSION

MAIN FLASH MEMORY : VP21AA (4.12)
MAIN ROM :          VP01AA (2.01)

```

Note

The numbers are examples only. Your system will show different numbers.

7.2.11 Custom Service Report (CREP)

Use the CREP command to display the Custom Service menu access count, the keypad assignments, message recording status and the tree-structure of the Custom Service.

Type CREP, Press Space, Enter the Custom Service number (1-100), and **Press RETURN**.

```

Custom [100] (System) (Access: 9) (Menu Msg. : None)
| < multilingual pick >
[N]- Xfer Mbx (998)
[0]- Operator
[1]- Custom [1] (System) (Access: 2) (Menu Msg. : None)
| | <English service>
| | [N]- Operator
| | [0]- Operator
| | [1]- A.A. Service
| | [2]- V.M.Service
| | [3]- FAX Transfer
| | [*]- Subscriber
[2]- Custom [2] (User -1) (Access: 2) (Menu Msg. : None)
| | <French service>
| | [N]- Operator
| | [0]- Operator
| | [1]- A.A. Service
| | [2]- V.M.Service
| | [3]- FAX Transfer
| | [*]- Subscriber
[3]- Custom [3] (User -2) (Access: 3) (Menu Msg. : None)
| | < Vietnamese service>
| | [N]- Operator
| | [0]- Operator
| | [1]- A.A. Service
| | [2]- V.M.Service
| | [3]- FAX Transfer
| | [*]- Exit
[4]- Dept Dial
[5]- Repeat Menu
[*]- Exit
[#]- Main Menu

```

Custom [100]:	Indicates that Custom Service No. is "100".
System:	Indicates that "System" prompts are active.
Access: 9:	Indicates that the callers have accessed this Custom Service 9 times. This counter can be cleared. See 7.2.12 Custom Service Menu Access Count Clear (CCLR).

Menu Msg. :None:	Indicates that the menu message for this Custom Service is "None (not recorded)". If menu message is recorded, "Rec" will appear.
[N]-Xfer Mbx (998):	Caller will be sent to General Delivery Mailbox (GDM) if he dials nothing.
[1]-Custom [1]:	Custom Service 1 will play when the "1" key is pressed.
[2]-Custom [2]:	Custom Service 2 will play when the "2" key is pressed.
[3]-Custom [3]:	Custom Service 3 will play when the "3" key is pressed.
[4]-Dept Dial:	Department Dialing menu will play when the "4" is pressed.

7.2.12 Custom Service Menu Access Count Clear (CCLR)

Each Custom Service has an access counter that counts the number of times the service has been accessed. This command clears this counter.

Type CCLR, Press Space, and Enter Custom Service Menu (1-100), then Press RETURN.

```
$ CCLR 20
Custom Menu <20> Access Counter Cleared !!
```

Note

Type CCLR 0 to clear the access counters of all Custom Services.

7.2.13 Message Waiting Lamp Retry Times (MWL)

Use the MWL command to specify the number of times the VPS will attempt to turn on the Message Waiting Lamp of the called extension. Apply this setting when a PBX other than the Panasonic KX-T series telephone system is used.

```
$ MWL
Current Setting of M.W.L. Retry Count is 3
Enter M.W.L. Retry Count (1-3) =
```

Note

This setting is not valid if "Message Waiting Lamp for Every Message" is set to "Yes".

7.2.14 Setting Minimum Recording Length (MRL)

Use the MRL command to specify the minimum message recording length (0-3 s). Messages shorter than the specified minimum recording length are discarded from the mailbox.

Note

The minimum recording length can only be set using this command.

1. Type MRL, then Press RETURN.

```

$ MRL
Current Setting of Minimum Recording Length is 2
Enter Minimum Recording Length (0-3) =
    
```

2. Type the message length.

7.2.15 Modified Prompt List (MPLT)

Use the MPLT command to display the user prompt recording status: recorded, not recorded, or turned off.

1. Type MPLT, then Press RETURN.

- MPLT —> both prompts
- MPLT 1 —> User 1 prompts
- MPLT 2 —> User 2 prompts

```

$ MPLT 1

***List of Registered User Prompt 1 No. ([1], [2], . . . , [914])***
, 1, , OFF, , 5*, 6, , , , , , , , , , ,
, , , , , , , , , , , , , , , ,
, , , , , , , , , , , , , , , ,
, , , , , , , , , , , , , , , ,

      •
      •
      •

, , , , , , , , , , , , , , , ,
, , , , , , , , , , , , , , , ,
, , , , , , , , , , , , , , , ,

*** Total number of Registered = 3 ***
*** Total number TURNED OFF = 2 ***
    
```

Blank:	The prompt has not been recorded (but the default [System Prompt] is active)—WILL BE HEARD
Prompt No.:	The prompt has been recorded—WILL BE HEARD
Prompt No. with an*:	The prompt has been recorded but is turned off—WILL NOT BE HEARD
"OFF":	The prompt has never been recorded and the default prompt has been turned off—WILL NOT BE HEARD

Note

The "Total Number of Registered" shown at the bottom of the screen does not include the prompts that have been turned off.

7.2.16 Utility Command List (HELP)

Use the HELP command to display the list of all available utility commands.

1. Type **HELP**, then Press **RETURN**.

```

$ HELP
OFLN      : System Off-line
ONLN      : System On-line
PASS      : Password setting
TIME      : Time & Date setting
PSET      : Report Print Out Time setting
ELOG      : Device Error Log Listing
SAVE      : VPS Program & Date Save (VPS → PC : Xmodem)
LOAD      : VPS Program & Date Load (VPS ← PC : Xmodem)
GPRN      : Parameter Global Printing (only 'ASCII Terminal' mode)
VERS      : Program Version Check
CREP [no.] : Custom Menu Information List
           [no] : Custom Menu No. (1-100)
CCLR [no.] : Custom Menu Access Counter Clear
           [no] : Custom Menu No. (1-100/0) (0: Clear All)
MWL       : MWL Retry count Set (1-3)
MRL       : Minimum Recording Length Set (0-3)
MPLT [opt] : Registered User Prompt No. List
           [opt] : 1   → User Prompt 1
                   2   → User Prompt 2
                   None → User Prompt 1&2
QSET      : Quick Setup
LMON      : Line Monitor
PUTD      : DTMF Information Display (Don't leave enabled after
           troubleshooting.)
WCID      : Wait Time for Caller ID
$

```

7.2.17 Quick Setup (QSET)

Use the QSET command initially to setup the VPS very roughly when you use it for the first time or after system initialization.

Note

Quick setup requires VT100 emulation software.

Type QSET, then Press RETURN.

7.2.18 Circuit Condition Display (LMON)

Use the LMON command to display the circuit condition every 1.5 s. To turn off this command, enter [N].

The following circuit conditions may be displayed.

"Ready"	: Possible to serve
"Incoming Call"	: Processing arrival service
"Outgoing Call"	: Processing sending service
"DSP Reset"	: Processing DSP reset disposition
"PT connect"	: Processing PT connect disposition
"Error"	: DSP Card is not loaded

```

$ LMON
  No.:  Status
    1:  Ready
    2:  Ready

```

7.2.19 Touchtone Information Display (PUTD)

Use the PUTD command to display the touchtones the VPS receives and sends.

In addition to the touchtones, the following will be displayed—the Incoming Call Service (Voice Mail, Automated Attendant, Custom, and Interview) entered by the caller and the time periods that the ports are enabled.

Type PUTD. The VPS will remain in this mode until "PUTD" is entered again. The default setting of this mode for all ports is "OFF".

```

$ PUTD
  Target Port : **
  Don't leave enabled after troubleshooting.
$

```

To change the mode from "PUTD" to "OFF", **Type PUTD** again.

```
$ PUTD
  Target Port : 00
  Don't leave enabled after troubleshooting.
$
```

Note

"*" means "enable" for the port. "0" means "disable" for the port.

To set the mode for only 1 port, **Type PUTD** and the port number.

```
$ PUTD 1
  Target Port : 0*
  Don't leave enabled after troubleshooting.
$
```

Sample display:

```
$ PUTD
  Target Port for Debug : * *
$
[1] DTMF:3
[1] DTMF:8
[1] A.Attend
[1] DTMF:#
[1] DTMF:6
[1] Voice Mail
[1] DTMF:1
[1] DTMF:0
[1] DTMF:1
[1] NonSub Svc
[1] * * *
[1] DTMF:#
[1] DTMF:9
[1] Thank you
```

WARNING

"PUTD" is a command originally used when troubleshooting. Do not use this command for any other purpose. Do not disconnect the RS-232C connection while the "PUTD" command is enabled. This could cause data overflow.

7.2.20 Wait for Caller ID (WCID)

Use the WCID command to specify the length of time (in seconds) the VPS must wait for the Caller ID after the VPS has received the incoming call from the PBX.

If Caller ID is not needed at all, set the waiting time to "0" to accelerate the VPS response to incoming calls.

Type WCID, then Press RETURN.

```
$ WCID  
  WAIT TIME FOR CALLER ID (5 sec) [0-60 sec] : = 0  
$
```

7.3 SYSTEM REPORTS

The System Administrator is able to generate 8 System Reports to monitor VPS operating status. The reports can be displayed on a data terminal or printed. The terminal or printer must be connected to the RS-232C port. (The System Manager is also able to output System Reports.)

To select the System Reports Menu, follow the menu path as shown:

System Administration Top Menu-2-1

```
System Reports – System Report Menu
  1. Mailbox Assignments
  2. COS Assignments
  3. System Service Report
  4. Call Account Report
  5. Port Usage Report
  6. Flash Memory Usage Report
  7. Mailbox Usage Report
  8. Fax Call Report
Enter the Number : =
```

The following 4 reports can be cleared of all values and prepared for use again.

To clear the following 4 reports, follow the menu path as shown:

System Administration Top Menu-2-2

```
System Reports System Clear Menu
  1. Port Usage Statistics Clear
  2. Flash Memory Usage Statistics Clear
  3. Mailbox Usage Statistics Clear
  4. Fax Call Report Clear
Enter the Number : =
```

7.3.1 Mailbox Assignments

The Mailbox Assignments report provides information about the applied mailbox authorized features and current parameter settings.

Note

Depending on the PBX extension numbering, the mailbox numbers might be 2- to 5-digit long.

To select the Mailbox Assignments Report, follow the menu path as shown:

System Administration Top Menu-2-1-1

**Mailbox Assignments						JUL-28-2001 11:30 AM **			
MBOX	Extn.	Name (Fir/Lst)	COS	CExtn	IVMBOX	AITrf	MN1st	MN2nd	MN3rd
510	201	JONE / DELY	2	601	621	-	---	---	---
511	202	SCHE /-----	2	602	611	-	Bep	Tel	---
512	203	MAY /-----	16	603	612	-	Tel	Bep	---
520	310	JONE /-----	1	--	-	X	---	Tel	Bep
521	320	DAVE /-----	1	--	888	-	---	---	---
522	410	CLUS / ALCC	21	--	-	-	---	---	---
523	421	WHIT / BLUE	32	--	642	-	---	---	---

- COS: Class of Service
- CExtn: Covering Extension
- AITrf: All Call Transfer to Mailbox
- MN2nd: Message Notification Device 2
- Bep: Beeper
- IVMBOX: Interview Mailbox
- MN1st: Message Notification Device 1
- MN3rd: Message Notification Device 3
- Tel: Telephone

Note

An 'X' displayed on the screen indicates that the feature marked with the X is set to "YES".

7.3.2 COS (Class of Service) Assignments

The COS (Class of Service) Assignments report provides information concerning all Class of Service numbers.

For a complete explanation of COS parameters, please see Tables 39 and 40 in B3 SYSTEM ADMINISTRATION—SETTING COS (CLASS OF SERVICE) PARAMETERS.

To select the COS Assignments Report, follow the menu path as shown:

System Administration Top Menu-2-1-2

** COS Assignments																				JUL-29-2001 11:30 AM **			
COS	GL	RtN	RtS	Ln	CaN	CaT	RO	SI	SP	CW	MC	DM	PG	Pr	RC	DC	CN	GC	CS	MN	ED (pr)	AF (mbox/ dl/ md)	
1	16	10	10	5	10	10	L	N	N	N	N	N	1	U1	N	N	30	Y	Y	X	X	U1	- - - - -
2	16	7	7	3	10	10	L	Y	N	N	N	N	2	U1	N	N	30	Y	Y	X	X	U1	- - - - -
3	8	7	7	3	10	10	F	Y	N	N	N	N	3	S	N	N	30	Y	Y	X	- - - - -	- - - - -	

63	-	30	6	Un	100	100	L	N	-	-	-	-	U1	N	N	-	-	-	X	-	-	-	-
64	-	30	6	6	100	100	L	N	-	-	-	-	U1	-	N	-	-	-	-	-	-	-	-

- | | | | |
|----------|---|------|---|
| COS: | Class of Service number | GL: | Personal Greeting Length |
| RtN: | New Message Retention | RtS: | Saved Message Retention Time |
| Ln: | Message Length Time (Un=Unlimited) | CaN: | Maximum Message |
| CaT: | Maximum Message Time (Un=Unlimited) | RO: | Message Retrieval Order (L=LIFO, F=FIFO) |
| SI: | Message Scanning with Information | SP: | Play System Prompt after Personal Greeting |
| CW: | Use Call Waiting on Busy | DM: | Direct Mailbox Access |
| PG: | Intercom Paging Group | Pr: | Prompt Mode (S=System Prompts, U1=User 1 Prompts, U2=User 2 Prompts) |
| RC: | Remote Call Forward to CO | DC: | Delete Message Confirmation |
| CN: | Maximum number of names for Personal Caller Name Announcement | GC: | Play Personal Greeting for Caller ID |
| CS: | Caller ID Screening | MN: | Authorization for Message Waiting Notification |
| ED (pr): | Authorization for External Message Delivery (Prompt Mode) (SY=System, U1=User 1, U2=User 2, SL=Selective) | AF: | Authorization for Auto Forwarding (mbox)=Mailbox No (dl)=Delay Time (md)=Forwarding Mode (M=move, C=copy) |

Note

An "X" displayed on the screen indicates that the feature marked with the X is set to "Yes".

To select the Call Account Report, follow the menu path as shown:

System Administration Top Menu-2-1-4

** Call Account					NOV-14-2001 3:40 PM**	
MBOX:111	JAN-4	7:46	PM	00:01:32	DIAL:91111111	
MBOX:116	JAN-7	2:26	PM	00:03:32	DIAL:92222222	
MBOX:114	JAN-7	5:06	PM	00:02:45	DIAL:93333333	
MBOX:118	JAN-8	9:07	AM	00:01:15	DIAL:94444444	
MBOX:112	JAN-8	10:24	AM	00:04:51	DIAL:95555555	

Note

Depending on PBX extension numbering, the mailbox numbers might be 2- to 5-digit long.

7.3.5 Port Usage Report

The Port Usage Report provides information about port usage and allows system and port traffic to be measured. The report includes the accumulated duration times of incoming and outgoing calling services and the total connect time for each port.

To select the Port Usage Report, follow the menu path as shown:

System Administration Top Menu-2-1-5

** Port Usage Report					JAN-4-2001 7:46 PM**	
FROM : : JAN-3-1999 9:53 AM						
Port	ED	MN	Rcv	Connect Time		
1	8	0	84	02:10:19		
2	4	0	21	00:18:54		
Total	9	0	105	02:39:13		
Full-line Time 00:10:15						

FROM: The date and time of the last clearing of this report

ED: External Delivery MN: Message Notification Rcv: Receive

Full-line Time: The total time that both ports were used simultaneously.

7.3.6 Port Usage Statistics Clear

Clears the Port Usage Report for use again.

To clear the Port Usage Statistics Report, follow the menu path as shown:

System Administration Top Menu-2-2-1

System Reports - System Report Clear - Port Usage Statistics Clear

May I clear port usage report data? (Y/N) : =

Type [Y] (yes) or **[N]** (no). If "Y" is entered, the system will clear the data. Wait until "Port Usage Report Data Cleared!!!" appears on the screen before proceeding.

7.3.7 Flash Memory Usage Report

The Flash Memory Usage Report indicates the amount of flash memory storage used and the flash memory availability in minutes. It also presents the following statistics:

- The number of messages that were recorded by callers and were copied since the last clearing of this report.
- The number of messages that were copied since the last clearing of this report.
- The number of messages that were deleted by subscribers, and expired and were removed by the system since the last clearing of this report.
- The number of messages that expired and were removed by the system since the last clearing of this report.

To select the Flash Memory Usage Report, follow the menu path as shown:

System Administration Top Menu-2-1-6

KX-TV50

** Flash Memory Usage Report				JAN-22-2001 8:30 PM **	
Drive	Avail	Used	(%)		
1	119 min	1min	(1)		
FROM : :		JAN-21-2001 10:20 PM **			
	New	Cpy	Del	Exp	
MSGs	10	0	10	0	

KX-TVS50 with an optional expansion memory card (KX-TVS52)

** Flash Memory Usage Report				JAN-22-2001 8:30 PM **	
Drive	Avail	Used	(%)		
1	119 min	1min	(1)		
2	120 min	0min	(0)		
FROM ::	JAN-21-2001 10:20 PM				
	New	Cpy	Del	Exp	
MSGs	10	0	10	0	

Drive: Specifies the memory card. "1" is the MASTER memory card (factory provided). "2" is the SLAVE memory card.

FROM: The date and time of the last clearing of this report

Cpy: Copy (Transfer) Del: Deleted Exp: Expired and Removed

7.3.8 Flash Memory Usage Statistics Clear

The Flash Memory Usage Report can be cleared of all values and prepared for use again.

To clear the Flash Memory Usage Report, follow the menu path as shown:

System Administration Top Menu-2-2-2

System Reports - System Report Clear - Flash Memory Usage Statistics Clear

May I clear Flash Memory usage report data ? (Y/N) : =

Type [Y] (yes) or **[N]** (no). If "Y" is entered, the system will clear the data. Wait until "Flash Memory Usage Report Data Cleared!!!" appears on the screen before proceeding.

7.3.9 Mailbox Usage Report

The Mailbox Usage Report provides information about the usage at specific mailbox. It includes the number of recorded messages, the total amount of outgoing calling time, and external message, message notification and group message delivery.

To select the Mailbox Usage Report, follow the menu path as shown:

System Administration Top Menu-2-1-7

Enter the Range : = 111

Note

Specify the range or the mailbox number. To obtain information on specific mailboxes from No.200 to No.209, Type [20] and Press RETURN, or [200] [,] [209] and Press RETURN.*

** Mailbox Usage Report					JAN-4-2001 7:46 PM**
MBOX:111 [JONE BLUE]					
New	MSGs	4			
Received	MSGs	6			
ED	MSGs	0			
FROM : :		JAN-3-2001 9:53 AM			
Subscriber Access Time		00:00:40			
MBOX Use Time		00:00:12 of 01:40:00 (1% Used)			
Feature Usage	ED	MN	IM	GM	AF
	11	31	20	14	22
Outcalling	LD	Lcl	Beep	Extn.	
(Time)	6	13	0	28	
	00:05:10	00:10:45	00:00:00	00:31:21	
MSG Received	Rcv	Del	Exp		
	42	30	11		

- | | |
|---|-----------------------|
| FROM: The date and time of the last clearing of this report | ED: External Delivery |
| MN: Message Notification | IM: Interview message |
| GM: Personal/System Group Distribution List | AF: Auto Forwarding |
| LD: Long distance call (8 digits or more) | |
| Lcl: Local call (less than 8 digits) | Rcv: Received |
| Del: Deleted | Exp: Expired |

Note

New MSGs, Received MSGs, and ED MSGs are current status indications. All else are accumulated indications since the last clearing of this report.

7.3.10 Mailbox Usage Statistics Clear

The Mailbox Usage Report can be cleared of all values and prepared for use again.

To clear the Mailbox Usage Report, follow the menu path as shown:

System Administration Top Menu-2-2-3

System Reports - System Report Clear - Mailbox Usage Statistics Clear

Enter the Range : =
 May I clear mailbox usage report data ? (Y/N) : =

Type [Y] (yes) or **[N]** (no). If "Y" is entered, the system will clear the data. Wait until "Mailbox Usage Report Data Cleared!!" appears on the screen before proceeding.

7.3.11 Fax Call Report

The Fax Call Report provides information about fax transfer when the VPS receives a fax signal. It includes the fax data receiving date, the port number used, and the fax transfer status for up to 64 fax messages.

To select the Fax Call Report, follow the menu path as shown:

System Administration Top Menu-2-1-8

** Fax Call Report NOV-14-2001 3:50 PM**

[DATE/TIME]	[PORT]	[FAX-1]	[FAX-2]
JAN-11 11:15 AM	1	connect	—
MAR-01 07:58 PM	2	(busy)	(no-ans.)
MAR-01 10:23 AM	1	(busy)	connect

.

FAX-1: Main facsimile machine FAX-2: Alternate facsimile machine

connect: Call was answered by the facsimile machine no-ans.: No Answer

7.3.12 Fax Call Statistics Clear

The Fax Call Report can be cleared of all values and prepared for use again.

To clear the Fax Call Statistics Report, follow the menu path as shown:

System Administration Top Menu-2-2-4

System Reports - System Report Clear - Fax Call Report Clear

May I clear fax call report data ? (Y/N) : =

Type [Y] (yes) or **[N]** (no). If "Y" is entered, the system will clear the data. Wait until "Fax Call Report Data Cleared!!" appears on the screen before proceeding.

7.4 TROUBLESHOOTING GUIDE

Table 31

PROBLEM	PROBABLE CAUSE	POSSIBLE SOLUTION
<i>Nothing is heard from the VPS when accessing the VPS.</i>	<ul style="list-style-type: none"> • Improper connection of jacks. • Bad connection with PBX. 	<ul style="list-style-type: none"> • Confirm that you are using the correct extension number for the VPS. Ask your System Administrator. • Check if the jacks of the VPS are connected to the proper jacks of the PBX (see 1.4 DIGITAL INTEGRATION). • Check the System Program [130] of the KX-TA624 to see if the programming agrees with the actual connection. • Check the System Program [117] of other KX-T series telephone systems that use DPT Integration to see if the programming agrees with the actual connection.
<i>Unable to utilize some of the DPT Integration features, even though DPT Integration has been established properly.</i>	<ul style="list-style-type: none"> • Your PBX cannot support the feature. • The software version of your PBX is lower than required. 	<ul style="list-style-type: none"> • Call National Parts Center at 1-800-833-9626.
<i>The VPS does not operate.</i>	<ul style="list-style-type: none"> • Bad printed circuit board. • Bad connection with PBX. • Incomplete card insertion. 	<ul style="list-style-type: none"> • Change the printed circuit board. • Check the connection between the VPS and PBX. • Insert the card firmly into the card slot.
<i>Dialing is not registered.</i>	<ul style="list-style-type: none"> • A pulse phone is being used by mistake. • Improper setting of integration mode. 	<ul style="list-style-type: none"> • Change to a touch tone phone. • Adjust the integration mode properly between the VPS and your PBX (see "Integration Mode" in Table 72 in B7.3 PBX Interface Parameters).

Table 31

PROBLEM	PROBABLE CAUSE	POSSIBLE SOLUTION
<p><i>Line disconnection occurs while transferring an outside call.</i> <i>Unable to transfer an outside call.</i></p>	<ul style="list-style-type: none"> • Improper setting of the sequence. • Improper setting of the hooking time. • Improper setting of the CPC signal. 	<ul style="list-style-type: none"> • Adjust the transfer sequence to that of the connected PBX and reset (see "Operator Transfer Sequence" and "Extension Transfer Sequence" in Table 74 in B7.3 PBX Interface Parameters). • Adjust the hooking time to that of the connected PBX and reset (see "Flash Time" in Table 70 in B7.2 Port Setting). • Adjust the CPC signal to that of the connected PBX and reset (see "CPC Signal" in Table 70 in B7.2 Port Setting).
<p><i>Unable to call an outside party.</i></p>	<ul style="list-style-type: none"> • Improper setting of the outside call dial procedure. 	<ul style="list-style-type: none"> • Reset the CO line access sequence of the connected PBX (see "Dial Number" in Table 37 in B2 SYSTEM ADMINISTRATION—MAILBOXES and "Number of Digits to Access Outside Line" in Table 61 in B6.7 Other Parameters). • Also check "Outgoing Call Setup Sequence" in Table 61 in B6.7 Other Parameters). • When setting a Dial Number for Device Notification or a telephone number for External Message Delivery, keep in mind the "Important Note" for "Dial Number" in Table 37 in B2 SYSTEM ADMINISTRATION—MAILBOXES.
<p><i>Unable to call an extension.</i></p>	<ul style="list-style-type: none"> • Improper setting of extension numbering plan. 	<ul style="list-style-type: none"> • Adjust the extension numbering plan properly (see "Numbering Plan 1-16" in Table 60 in B6.7 Other Parameters).

Table 31

PROBLEM	PROBABLE CAUSE	POSSIBLE SOLUTION
<i>Unable to access the mailbox.</i>	<ul style="list-style-type: none"> Improper setting of the mailbox number. 	<ul style="list-style-type: none"> Readjust the number of digits in the mailbox number (see "Mailbox Number" in Table 35 in B2 SYSTEM ADMINISTRATION—MAILBOXES).
<i>Unable to access to Operator 1</i>	<ul style="list-style-type: none"> Improper setting of the operator extension number. 	<ul style="list-style-type: none"> Adjust the operator extension number to that of the connected PBX (see "Operator's Extension" in Table 44 in B5.1 Automated Attendant Parameters).
<i>Connected terminal (RS-232C port) does not operate.</i>	<ul style="list-style-type: none"> Improper connection. Improper setting of the parameter. 	<ul style="list-style-type: none"> Be sure you are using a null modem cable (see 2.8 TERMINAL CONNECTION). The terminal and VPS should have the same parameter settings for Baud Rate, Word Bit Length, Parity and Stop Bit Length (see B7.1 RS-232C Parameters).
<i>Unable to make reconnection when the line is busy.</i>	<ul style="list-style-type: none"> Improper setting of the busy signal reconnection procedure. 	<ul style="list-style-type: none"> Readjust the busy signal reconnection procedure to that of the connected PBX (see "Reconnect Sequence on Busy" in Table 74 in B7.3 PBX Interface Parameters).
<i>Unable to make a no-response reconnection.</i>	<ul style="list-style-type: none"> Improper setting of the no-response reconnection procedure. 	<ul style="list-style-type: none"> Readjust the no-response reconnection procedure to that of the connected PBX (see "Reconnect Sequence on No Answer" in Table 74 in B7.3 PBX Interface Parameters).
<i>Unable to generate a call waiting tone from the VPS.</i>	<ul style="list-style-type: none"> Improper setting of sequence. 	<ul style="list-style-type: none"> Adjust the Call Waiting sequence to that of the connected PBX (see "Call Waiting Sequence" in Table 74 in B7.3 PBX Interface Parameters).

Table 31

PROBLEM	PROBABLE CAUSE	POSSIBLE SOLUTION
<i>Unable to make an Intercom Paging for groups.</i>	<ul style="list-style-type: none">• Improper setting of the Intercom Paging access code.	<ul style="list-style-type: none">• Adjust the Intercom Paging access code to that of the connected PBX (see "Paging Code for Group 1-8" and "Paging Code for All Groups" in Table 66 in B6.7 Other Parameters).

7.5 SPECIFICATIONS

Table 32

Port:	2 Digital/Analog ports	
Dialing Method:	Touchtone/Pulse (10/20 pps)	
Flash Time:	100 ms/300 ms/600 ms/900 ms (programmable)	
CPC Detection	None/6.5 ms/150 ms/300 ms/450 ms/600 ms (programmable)	
Type of Line:	Loop start minimum Loop Current: 20 mA minimum Line Voltage: 7 V DC minimum Ringing Voltage: 40 V AC	
Extension Numbering:	2 to 5 digits (programmable)	
Pause Time:	1 s to 9 s (programmable)	
Message Waiting Lamp:	Programmable Touchtone sequence	
Main CPU:	16-bit microprocessor	
Flash Memory Capacity:	Approximately 2 h (expandable)	
Number of Mailboxes:	Maximum 32 (including System Manager and Message Manager mailboxes)	
Number of Messages:	Maximum 100 per mailbox (programmable)	
Personal Greeting Message Length:	8 s to 60 s (programmable)	
Message Retention Time:	1 to 30 days or unlimited (programmable)	
Maximum Message Length:	1 min to 6 min, or unlimited length (programmable)	
Reports:	Mailbox Assignment, COS (Class of Service) Assignment, System Service Report, Call Account Report, Port Usage Report, Flash Memory Usage Report, Mailbox Usage Report, FAX Call Report	
Connections	Telephone Line:	Modular connectors × 2 <ul style="list-style-type: none"> • In case of Inband, 2-conducotor wire × 2 • In case of APT, 4-conducotor wire with APT Interface × 2 • In case of DPT, 4-conducotor wire with DPT Interface × 1
	Data Port:	RS-232C interface port
Environmental Requirements:	0 °C to 40 °C {32 °F to 104 °F}, 10 % to 90 % relative humidity	
Power Source:	120 V AC, 60 Hz	
Power Consumption:	Approximately 10 W	
Dimensions (H × W × D):	173 mm × 318 mm × 65 mm {6-13/16" × 12-1/2" × 2-9/16"}	
Mass (Weight):	Approximately 1.2 kg {2.7 lb.}	

Appendix A
SYSTEM FEATURES

A1 SYSTEM FEATURES

The Voice Processing System has many features that are available to the System Administrator, the System Manager, and/or System Subscribers. The Table 33 lists and briefly describes each key VPS system feature. In addition, references to specific sections of this manual and the Subscriber's Guide are provided in the references column that pertains to each feature listed. The specific procedure steps required to initiate, access, or utilize each feature are detailed at these references.

Note

Depending on the model and/or the software version of the connected PBX, you may not be able to utilize some of the features available only with DPT Integration. For more information, call National Parts Center at 1-800-833-9626.

Table 33

FEATURE	DESCRIPTION	REFERENCES
Alternate Extension Group	a group of extensions, which require a different call transfer sequence than normal, placed into a separate group.	<ul style="list-style-type: none"> • See "Dialing Parameters" in 3.2.4 PBX Interface Parameters. • See "Alternate Extension Assignment" in B5.1 Automated Attendant Parameters. • See "Alternate Extension Group" in Glossary.
APT Integration	is the interface data link that permits certain information and command functions to be sent to the VPS from the PBX. The information and command functions include: Auto Configuration, Caller ID Call Routing, Caller Name Announcement (System/Personal), Direct Mailbox Access, Intercom paging, Live Call Screening, Personal Greeting for Caller ID Two-Way Recording, Two-Way Transfer.	<ul style="list-style-type: none"> • See "VOICE MAIL" in 1.3.3 Which Phone Systems are Compatible?. • See 1.4.1 General. • See 1.4.2 APT Integration. • See 1.4.3 Connection Example—APT Integration. • See 2.7 CONNECTIONS. • See 3.1.1 APT/DPT or Inband Signaling? • See INTEGRATING THE VPS WITH THE PANASONIC KX-TA SERIES PBX AND KX-TD SERIES PBX. • See "APT Integration" in Glossary.

Table 33

FEATURE	DESCRIPTION	REFERENCES
Auto Configuration (APT/DPT Integration Only)	<p>creates mailboxes by obtaining extension numbers from the Panasonic KX-TA624 or other KX-T series telephone system that uses DPT Integration.</p> <p>Also sets the time and date automatically by obtaining time information from the PBX.</p>	<ul style="list-style-type: none"> • See "System Components" in 1.3.2 System Components. • See 4.1 GUIDELINES FOR DIGITAL INTEGRATION. • See "Creating Mailboxes" in 5.1.3 Starting the Quick Setup. • See "The length of mailbox numbers" in 5.1.3 Starting the Quick Setup. • See "Auto Configuration" in Glossary.
Auto Forwarding	<p>moves or copies unretrieved messages from one mailbox to another, after a specified period of time. This service is only available to subscribers (you cannot auto forward messages to the System Group Distribution Lists). Class of Service programming determines the mailboxes that can use this feature. Messages marked as "private" cannot be forwarded. Also, a message is never forwarded to the original sender of the message.</p>	<ul style="list-style-type: none"> • See "Private Message" in this Table. • See "Authorization for Auto Forwarding" in Table 39 in B3 SYSTEM ADMINISTRATION—SETTING COS (CLASS OF SERVICE) PARAMETERS. • See C3 SETTING COS (CLASS OF SERVICE) PARAMETERS. • See "Auto Forwarding" in Glossary.
Automated Attendant	<p>answers incoming calls and routes those calls to the desired extension. The service can be assigned to all of Day, Night, Lunch, and Break time periods. Available for both Port and Trunk Services.</p>	<ul style="list-style-type: none"> • See 5.2.10 Automated Attendant. • See 5.4 AUTOMATED ATTENDANT PARAMETERS. • See B5.1 Automated Attendant Parameters. • See "Automated Attendant" in Glossary.
Broadcasting Messages	<p>permits the System Manager to deliver the same message to all VPS subscribers at the same time.</p> <p>This feature is only available to the System Manager.</p>	<ul style="list-style-type: none"> • See "Delivering Messages to All Mailboxes (Broadcasting Messages)" in C7 DELIVERING MESSAGES.

Table 33

FEATURE	DESCRIPTION	REFERENCES
Busy Coverage Mode	specifies how the VPS will handle calls to the operator when the line is busy. The Busy Coverage options that are available include: Hold, No Answer Coverage, Call Waiting, and Disconnect Message.	<ul style="list-style-type: none"> • See "Busy Coverage Mode" in Table 23 in 5.4.3 Operator's Parameters. • See "Busy Coverage Mode" in Tables 44, 45 and 46 in B5 SYSTEM ADMINISTRATION—SERVICE SETTINGS.
Call Services	include a series of both incoming and outgoing call services. Incoming Call Services: Automated Attendant Service, Voice Mail Service, Interview Service, Custom Service. Outgoing Call Services: Message Waiting Notification, and External Message Delivery.	<ul style="list-style-type: none"> • See "Port Service Setting" in 5.1.3 Starting the Quick Setup. • See "Incoming Call Service" in Table 22 in 5.3.1 Port Service Menu. • See "Incoming Call Service" in Table 41 in B4.1 Port Assignment. • See "Incoming Call Service" in Table 42 in B4.2 Trunk Group Assignment.
Call Transfer Status	permits subscribers to specify how the VPS will handle calls to their individual extensions. Call Transfer Status options include: Call Screening, Call Blocking, Intercom Paging, and Calling a Beeper.	<ul style="list-style-type: none"> • See "Calling a Beeper" and "Intercom Paging (APT/DPT Integration Only)" in this Table. • See "Call Transfer" in Glossary. • See 4.1 Call Transfer Status in the Subscriber's Guide.

Table 33

FEATURE	DESCRIPTION	REFERENCES
Callback Number Entry	enables the caller to leave a callback number in several different ways depending upon which option is programmed into the VPS. The VPS can forward the callback number to a beeper.	<ul style="list-style-type: none"> • See "Notification Setting" in B2 SYSTEM ADMINISTRATION—MAILBOXES. • See "Beeper Callback No. Entry Mode" in Tables 39 and 40 in B3 SYSTEM ADMINISTRATION—SETTING COS (CLASS OF SERVICE) PARAMETERS. • See "Other Parameters-Message Waiting Notification" in B6.7 Other Parameters. • See C3 SETTING COS (CLASS OF SERVICE) PARAMETERS.
Caller ID Call Routing (APT/DPT Integration Only)	allows the System Administrator to assign up to 120 Caller ID numbers and program the route for the calls from these assigned numbers to the desired extension, mailbox (System Group Distribution List included) or Custom Service.	<ul style="list-style-type: none"> • See 4.1 GUIDELINES FOR DIGITAL INTEGRATION. • See B5.3 Caller ID Call Routing Parameters. • See "Caller ID Call Routing" in Glossary.
Caller ID Screening (APT/DPT Integration Only)	allows extension users to hear prerecorded caller names when calls from assigned numbers are transferred from the VPS to the extension users.	<ul style="list-style-type: none"> • See "Caller Name Announcement—Personal" and "Caller Name Announcement—System" in this Table.

Table 33

FEATURE	DESCRIPTION	REFERENCES
<p>Caller Name Announcement—Personal (APT/DPT Integration Only)</p>	<p>allows subscribers to assign up to 30 Caller ID numbers and record a caller name for each Caller ID number from their telephone. The caller name is announced when: (1) subscribers listen to the messages from assigned numbers left in their mailboxes, (2) the VPS transfers calls from assigned numbers to the subscribers (Caller ID Screening), and (3) the VPS pages the subscribers by intercom (Intercom Paging). Caller ID Screening is enabled or disabled in the COS (Class of Service) settings.</p> <p>If the same Caller ID number is programmed for both the system and personal caller name announcement, the VPS will use the personal caller name.</p>	<ul style="list-style-type: none"> • See 4.1 GUIDELINES FOR DIGITAL INTEGRATION. • See "Number of CIDs for Caller Name Announcement" and "Caller ID Screening" in Table 39 in B3 SYSTEM ADMINISTRATION—SETTING COS (CLASS OF SERVICE) PARAMETERS. • See C3 SETTING COS (CLASS OF SERVICE) PARAMETERS. • See "Caller Name Announcement (System/Personal)" in Glossary. • See 4.12 Personal Caller Name Announcement in the Subscriber's Guide.
<p>Caller Name Announcement—System (APT/DPT Integration Only)</p>	<p>allows the System Administrator to assign up to 120 Caller ID numbers. Each Caller ID number can have a caller name recorded by the Message Manager. The caller name is announced when: (1) extension users listen to the messages from assigned numbers left in their mailboxes, (2) the VPS transfers calls from assigned numbers to the subscribers (Caller ID Screening), and (3) the VPS pages the subscribers by intercom (Intercom Paging). Caller ID Screening is enabled or disabled in the COS (Class of Service) settings.</p> <p>If the same Caller ID number is programmed for both the system and personal caller name announcement, the VPS will use the personal caller name.</p>	<ul style="list-style-type: none"> • See 4.1 GUIDELINES FOR DIGITAL INTEGRATION. • See "Caller ID Screening" in Table 39 in B3 SYSTEM ADMINISTRATION—SETTING COS (CLASS OF SERVICE) PARAMETERS. • See B6.6 System Caller Name Announcement. • See C3 SETTING COS (CLASS OF SERVICE) PARAMETERS. • See "Recording System Caller Names" in D6 RECORDING MESSAGES. • See "Caller Name Announcement (System/Personal)" in Glossary.

Table 33

FEATURE	DESCRIPTION	REFERENCES
Calling a Beeper	<p>allows a subscriber to be notified by a beeper when he has message(s). If the beeper has a display, it is possible to send to it a callback number. The callback number can be recorded when a caller leaves a message. If the caller does not leave a callback number, the System Callback No., or the caller's number if it is received through a telephone company's Caller ID service, will be sent instead.</p> <p>To utilize this feature, follow the procedure below.</p> <p>1) Go to the System Administration Top Menu, and type 1-2 (Program-Class of Service) and COS No.(1-63). Select "Yes" in the Authorization for Message Notification parameter. Make 1 selection from the available options in the Beeper Callback No. Entry Mode parameter.</p> <p>2) From the System Administration Top Menu, type 1-1-1-Mailbox No.-Y-2-Device No.(1-3) (Program-Mailbox Setting-Enter/Edit-Mailbox No. Entry-Do you want to edit this mailbox?-Notification Setting-Device No. Entry). For the Dial Number parameter: enter your PBX's line access code before the beeper number for dialing outward; enter an X after the beeper number. (The X is for the caller to enter his number as the callback number which will later appear on your beeper.) Finally, select "Beeper" in the Type of Device parameter.</p>	<ul style="list-style-type: none"> • See "Dial Number" and "Type of Device" in Table 37 in B2 SYSTEM ADMINISTRATION—MAILBOXES. • See "Authorization for Message Notification" and "Beeper Callback No. Entry Mode" in Tables 39 and 40 in B3 SYSTEM ADMINISTRATION—SETTING COS (CLASS OF SERVICE) PARAMETERS. • See "System Callback Number" in Table 62 in B6.7 Other Parameters. • See C3 SETTING COS (CLASS OF SERVICE) PARAMETERS.

Table 33

FEATURE	DESCRIPTION	REFERENCES
Class of Service (COS)	<p>There are 62 COS levels for subscribers. COS 63 is for the Message Manager and COS 64 is for the System Manager.</p> <p>Either the System Administrator (using a personal computer) or the System Manager (using a telephone) can change COS assignments.</p>	<ul style="list-style-type: none"> • See 7.3.2 COS (Class of Service) Assignments. • See B3 SYSTEM ADMINISTRATION—SETTING COS (CLASS OF SERVICE) PARAMETERS. • See "Creating and Editing a Mailbox" in C2 SETTING UP MAILBOXES. • See C3 SETTING COS (CLASS OF SERVICE) PARAMETERS.
Covering Extension	<p>forwards calls to a second extension when the first extension's subscriber is not available to take the call. The caller can also access the Covering Extension by pressing [0] while a Personal Greeting is being played, or while leaving a message.</p>	<ul style="list-style-type: none"> • See "Covering Extension" in Table 36 in B2 SYSTEM ADMINISTRATION—MAILBOXES. • See "Covering Extension" in Glossary. • See 4.2 Covering Extension in the Subscriber's Guide.
Custom Service	<p>allows callers to access specific functions by entering numbers or symbols through the telephone keypad.</p> <p>The Message Manager can record up to 100 Custom Service menus. These menus can be recorded in various foreign languages, and help guide outside callers to the desired extension, mailbox, System Group Distribution List, Department Dialing menu, operator, fax machine, etc.</p> <p>Note: Callers cannot jump between Custom Service menus more than 8 times.</p>	<ul style="list-style-type: none"> • See 5.2 PORT SETTING OPTIONS. • See 7.2.11 Custom Service Report (CREP). • See 7.2.12 Custom Service Menu Access Count Clear (CCLR). • See B5.2 Custom Service. • See "Recording Menus and Voice Labels" in D6 RECORDING MESSAGES. • See "Custom Service Setting" in Glossary.
Daylight Saving Time Assignment	<p>changes the internal clock of the VPS for the start and end of Daylight Saving Time.</p>	<ul style="list-style-type: none"> • See B6.4 Daylight Saving Time (DST).

Table 33

FEATURE	DESCRIPTION	REFERENCES
Delete Message Confirmation	<p>requests confirmation from mailbox owner before erasing a message left in the mailbox.</p> <p>This feature can be enabled or disabled in the COS (Class of Service) settings.</p>	<ul style="list-style-type: none"> • See "Delete Message Confirmation" in Tables 39 and 40 in B3 SYSTEM ADMINISTRATION—SETTING COS (CLASS OF SERVICE) PARAMETERS. • See C3 SETTING COS (CLASS OF SERVICE) PARAMETERS.
Department Dialing	<p>is a speed-dialing feature that permits the caller to quickly reach the desired extension by dialing a 1 digit number either during or after the playing of the Department Dialing message.</p>	<ul style="list-style-type: none"> • See 5.4.2 Department Dialing. • See "Department Dialing" in B5.1 Automated Attendant Parameters. • See "Recording Menus and Voice Labels" in D6 RECORDING MESSAGES. • See "Department Dialing" in Glossary.
Dialing by Name	<p>allows the caller to reach the intended mailbox/extension (when the number is not known) by entering the first 3 or 4 letters of the mailbox owner's last name. The VPS identifies all subscribers with that letter combination and states each name for the caller. The caller selects the desired subscriber by entering the appropriate number.</p>	<ul style="list-style-type: none"> • See "Owner Last Name" in Table 36 in B2 SYSTEM ADMINISTRATION—MAILBOXES.
Direct Mailbox Access (APT/DPT Integration Only)	<p>allows subscribers to call the VPS and access their mailbox without entering the mailbox number.</p>	<ul style="list-style-type: none"> • See 4.1 GUIDELINES FOR DIGITAL INTEGRATION. • See "Direct Mailbox Access" in Table 39 in B3 SYSTEM ADMINISTRATION—SETTING COS (CLASS OF SERVICE) PARAMETERS. • See C3 SETTING COS (CLASS OF SERVICE) PARAMETERS. • See "Direct Mailbox Access" in Glossary.

Table 33

FEATURE	DESCRIPTION	REFERENCES
DPT Integration	<p>is the interface data link that permits certain information and command functions to be transmitted between the VPS and PBX. The information and command functions include: Remote Call Forwarding Set, Auto Configuration, Caller ID Call Routing, Caller Name Announcement (System/Personal), Direct Mailbox Access, Intercom Paging, Live Call Screening, Personal Greeting for Caller ID, Time Synchronization with PBX, Two-Way Record and Two-Way Transfer.</p> <p>Note: Depending on the model and/or the software version of the connected PBX, you may not be able to utilize some of the features available only with DPT Integration. For more information, call National Parts Center at 1-800-833-9626.</p>	<ul style="list-style-type: none"> • See "Voice Mail" in 1.3.3 Which Phone Systems are Compatible? • See 1.4.1 General. • See 1.4.4 DPT Integration. • See 1.4.5 Connection Example—DPT Integration. • See 2.7 CONNECTIONS. • See 3.1.1 APT/DPT or Inband Signaling? • See Section 4 INTEGRATING THE VPS WITH THE PANASONIC KX-TA SERIES PBX AND KX-TD SERIES PBX. • See "DPT Integration" in Glossary.
Extension Group	<p>places several extensions into the same mailbox to share information using an Extension Group List. The System Administrator must establish this list. The VPS can maintain up to 20 lists with a maximum of 20 entries on each.</p>	<ul style="list-style-type: none"> • See 5.2.8 Extension Groups. • See "System Group Assignment-Extension Group" in B6.1 System Group Assignment.
Extension Numbering Plan	<p>permits the VPS to recognize an extension number as valid.</p>	<ul style="list-style-type: none"> • See "Other Parameters-Extension Numbering Plan" in B6.7 Other Parameters.
External Message Delivery List	<p>allows a subscriber to send a message to outside parties and/or extensions with a single operation. One subscriber can maintain up to 2 lists with a maximum of 8 entries on each.</p> <p>This feature is only available when External Message Delivery has been authorized for the subscriber's COS.</p>	<ul style="list-style-type: none"> • See "External Message Delivery Service" in this Table. • See "External Delivery Message", "External Message Delivery List", and "External Message Delivery Redial" in Glossary. • See 3.3 Setting up an External Message Delivery List in the Subscriber's Guide.

Table 33

FEATURE	DESCRIPTION	REFERENCES
External Message Delivery Service	<p>allows a subscriber to send a message to several subscribers and non-subscribers (including outside parties) at a specified time (or immediately). This feature also permits the receiver to reply to the message without having to specify the mailbox number.</p> <p>If the sender wishes, he can require the receiver to enter a 4-digit password to receive the sender's message. If the receiver enters the password incorrectly 3 times, the VPS: (1) plays the Callback Telephone Number (if registered), and (2) plays the sender's extension (if both the Callback Telephone Number and the Extension of the Owner have been registered). With this information, the receiver can possibly track down the message even if he does not remember the password.</p> <p>COS programming determines whether this feature can be used or not.</p>	<ul style="list-style-type: none"> • See "The Extension of the Owner" in Table 36 in B2 SYSTEM ADMINISTRATION—MAILBOXES. • See "Authorization for External Message Delivery" in Table 39 in B3 SYSTEM ADMINISTRATION—SETTING COS (CLASS OF SERVICE) PARAMETERS. • See "Other Parameters-External Message Delivery" in B6.7 Other Parameters. • See C3 SETTING COS (CLASS OF SERVICE) PARAMETERS. • See "External Delivery Message", "External Message Delivery List", and "External Message Delivery Redial" in Glossary. • See 3.4 Sending External Delivery Messages in the Subscriber's Guide. • See 3.5 Receiving External Delivery Messages in the Subscriber's Guide. • See 3.6 Replying to External Delivery Messages in the Subscriber's Guide.
External Message Delivery Status	<p>allows the subscriber to check the status of undelivered and pending external delivery messages.</p> <p>This feature is only available when External Message Delivery has been authorized for the subscriber's COS.</p>	<ul style="list-style-type: none"> • See "External Message Delivery Service" in this Table. • See "External Delivery Message", "External Message Delivery List", and "External Message Delivery Redial" in Glossary. • See 3.7 Checking and Setting External Message Delivery Status in the Subscriber's Guide.

Table 33

FEATURE	DESCRIPTION	REFERENCES
Fax Management	<p>allows the VPS to automatically route an incoming fax signal to a specific fax machine. Up to 2 fax machines can be assigned using this feature. Outside callers can also reach the fax machine via Custom Service selection, if programmed.</p> <p>A special mailbox can be assigned to the Fax Manager. In this way, the VPS can notify the Fax Manager of the status of faxes.</p>	<ul style="list-style-type: none"> • See "Fax Management (1-5-7-8)" in 5.2.2 Custom Service Features. • See 7.3.11 Fax Call Report. • See 7.3.12 Fax Call Statistics Clear. • See "Other Parameters-Fax Management" in B6.7 Other Parameters.
Group Distribution List—Personal	<p>allows a subscriber to simultaneously send a message to several mailboxes using a Group Distribution List. This list is established by the subscriber. Each subscriber can maintain a maximum of 4 lists with up to 20 entries on each list.</p>	<ul style="list-style-type: none"> • See "Group Distribution List—System" in this Table. • See "Personal Group Distribution List" in Glossary. • See 4.5 Personal Group Distribution Lists in the Subscriber's Guide. • See 4.6 Deleting Group Distribution Members in the Subscriber's Guide. • See 4.7 Deleting Group Distribution List Names in the Subscriber's Guide.
Group Distribution List—System	<p>allows a subscriber to send a message to several mailboxes using a Group Distribution List. Also allows a caller to record a message into all mailboxes within the list. The System Administrator must establish this list. The VPS can maintain up to 20 lists with a maximum of 20 entries on each.</p>	<ul style="list-style-type: none"> • See "System Group Assignment-Mailbox Group" in B6.1 System Group Assignment. • See C7 DELIVERING MESSAGES. • See "System Group Distribution List" in Glossary.
Hold	<p>provides the caller with the option of temporarily holding the call when the line is busy. The VPS automatically recalls the extension after a specified period of time. When several callers hold their calls to the same extension, callers are connected in the order in which they originally called.</p>	<ul style="list-style-type: none"> • See "Other Parameters-Call Hold" in B6.7 Other Parameters.

Table 33

FEATURE	DESCRIPTION	REFERENCES
Holiday Service	<p>permits the VPS to record, store, and play several different holiday greetings. Up to 20 Holiday Service settings can be programmed.</p> <p>It is possible to either specify a single day or a range of days on which to enable the Holiday Service setting.</p> <p>Note: Holidays cannot overlap.</p>	<ul style="list-style-type: none"> • See B6.3 Holiday Setting.
Inband Integration	<p>allows the PBX, using Inband Integration, to send information to the VPS using Touchtones. Inband integration is characterized as Voice Mail Integration and Touchtone Integration. Voice Mail Integration works with the Call Forwarding Feature of the PBX to permit a caller to leave a message when the mailbox number of the called extension is not known. Touchtone Integration works with the Automated Attendant Service to enable the VPS to immediately recognize the state of the call (busy, answered, ringing, etc.) and improve its call handling performance.</p>	<ul style="list-style-type: none"> • See "Voice Mail" in 1.3.3 Which Phone Systems are Compatible? • See 2.7 CONNECTIONS. • See 3.1.1 APT/DPT or Inband Signaling?. • See Section 3 INTEGRATING THE VPS WITH PANASONIC KX-T PHONE SYSTEMS. • See "Inband Signaling" in Glossary.
Incomplete Call Handling Service	<p>allows the subscriber to offer callers several service options when the extension is busy or there is no answer: Leaving a Message, Transfer to Covering Extension, Returning to the Automated Attendant Top Menu, Intercom Paging, Calling a Beeper, or Calling Operators.</p>	<ul style="list-style-type: none"> • See "Calling a Beeper" and "Intercom Paging (APT/DPT Integration Only)" in this Table. • See "Incomplete Call Handling Service" in Glossary. • See 4.3 Incomplete Call Handling Status in the Subscriber's Guide.

Table 33

FEATURE	DESCRIPTION	REFERENCES
Intercom Paging (APT/DPT Integration Only)	<p>permits callers to page subscribers by PBX paging (there are different kinds of PBX paging, and these can be specified by VPS programming) when the subscribers have set Intercom Paging for Call Transfer or when the subscribers have set Intercom Paging for Incomplete Call Handling. The caller is briefly placed on hold while the VPS announces the page and until the subscriber answers the page. The subscriber can answer the page from any extension using the paging answer code; this code is specified in the PBX User Manual. For a Caller ID Caller, if his name has been recorded for the Caller Name Announcement feature, the name will be announced at the end of the page. If the caller's name has been recorded for both the System and Personal Caller Name Announcement, the VPS will use the personal caller name.</p> <p>To utilize this feature, follow the procedure below.</p> <p>1) Go to the System Administration Top Menu, and type 1-2 (Program-Class of Service) and COS No.(1-62). Select an Intercom Paging Group (1-9) for this COS. If set to Group 9, the Intercom Paging feature is activated for all groups.</p> <p>2) From the System Administration Top Menu, type 1-5-7-7 (Program-System Parameter Setting-Others-Intercom Paging Parameters). Adjust the "No Answer Time for Intercom Paging" to your preference (the default is 5 s). For the Intercom Paging Group you selected in Step 1, set the Intercom Paging access code in "Paging Code for Group 1-9" and "Paging Code for All Groups".</p>	<ul style="list-style-type: none"> • See 4.1 GUIDELINES FOR DIGITAL INTEGRATION. • See "Intercom Paging (1-5-7-7)" in 5.2.2 Custom Service Features. • See "Intercom Paging Group" in Table 39 in B3 SYSTEM ADMINISTRATION—SETTING COS (CLASS OF SERVICE) PARAMETERS. • See "Other Parameters-Intercom Paging Parameter" in B6.7 Other Parameters. • See "Intercom Paging" in Glossary.

Table 33

FEATURE	DESCRIPTION	REFERENCES
Interview Service	plays a set of recorded questions when a caller accesses the service. The caller is provided an opportunity to answer each question after it has been asked. Subscribers are able to record questions directly into their own Interview Mailbox.	<ul style="list-style-type: none">• See 5.2.9 Interview Service.• See "Interview Mailbox Number" in Table 36 in B2 SYSTEM ADMINISTRATION—MAILBOXES.• See "Creating and Editing a Mailbox" in C2 SETTING UP MAILBOXES.• See "Interview Service" in Glossary. • See 4.9 Interview Mailbox in the Subscriber's Guide.

Table 33

FEATURE	DESCRIPTION	REFERENCES
Live Call Screening (APT/DPT Integration Only)	<p>permits the subscriber to monitor incoming calls as messages are being recorded. The subscriber has the option of answering calls while monitoring or allowing the message to be recorded without interruption. There are two modes in this feature: Hands-free and Private.</p> <p>Hands-free permits the subscriber to hear the caller through the telephone's speaker and answer the call by lifting the handset. The Private Mode alerts by tone and requires the telephone handset to be lifted before the message can be monitored. Two-way communication is established by pressing the feature button.</p>	<ul style="list-style-type: none"> • See 4.1 GUIDELINES FOR DIGITAL INTEGRATION. • See 4.4.1 Live Call Screening (LCS) Programming. • See 4.4.2 Live Call Screening Password Assignment. • See 4.4.3 Live Call Screening Password Canceling. • See 4.4.4 Live Call Screening Recording Mode Assignment via System Programming. • See 4.4.5 Live Call Screening Private/Hands-Free Mode Assignment via Station Programming. • See 4.4.6 Live Call Screening Button Assignment via Station Programming. • See 4.4.7 Live Call Screening Cancel Button Assignment via Station Programming. • See 4.4.11 Live Call Screening Activation. • See 4.4.12 Live Call Screening Password Control. • See "Message Cancel for Live Call Screening" in Table 39 in B3 SYSTEM ADMINISTRATION—SETTING COS (CLASS OF SERVICE) PARAMETERS. • See C3 SETTING COS (CLASS OF SERVICE) PARAMETERS. • See "Live Call Screening" in Glossary. • See 4.13 Live Call Screening in the Subscriber's Guide.

Table 33

FEATURE	DESCRIPTION	REFERENCES
Logical Extension (All Calls Transfer to Mailbox)	is an extension that always receives calls directly into its mailbox. This feature is used by subscribers that are often unavailable or that do not have a telephone.	<ul style="list-style-type: none"> • See "All Calls Transfer to Mailbox" in Table 36 in B2 SYSTEM ADMINISTRATION—MAILBOXES. • See "Creating and Editing a Mailbox" in C2 SETTING UP MAILBOXES. • See "Logical Extension" in Glossary.
Mailbox	is a place where all messages to a subscriber are stored. Several mailbox options exist: Subscriber Mailbox, Interview Mailbox, System Manager's Mailbox, and Message Manager's Mailbox (General Delivery Mailbox).	<ul style="list-style-type: none"> • See 5.5 SETTING MAILBOXES. • See 6.2 SETTING UP MAILBOXES. • See 7.3.1 Mailbox Assignments. • See 7.3.9 Mailbox Usage Report. • See 7.3.10 Mailbox Usage Statistics Clear. • See B2 SYSTEM ADMINISTRATION—MAILBOXES. • See C2 SETTING UP MAILBOXES. • See Section 1 Mailbox Setup in the Subscriber's Guide.
Message Delivery, Internal	allows the VPS to automatically deliver a single message to multiple mailboxes.	<ul style="list-style-type: none"> • See "Group Distribution List—Personal", "Group Distribution List—System" and "Message Delivery Status" in this Table.

Table 33

FEATURE	DESCRIPTION	REFERENCES
Message Delivery Status	<p>allows a subscriber to check the status of messages that have been sent. The sending subscriber has the option of canceling any of the messages after checking their status. If a recorded message has not been received, the VPS will voice report the following: the message's destination mailbox number and its contents.</p> <p>Message delivery status information is automatically deleted after the message has been received by the subscriber, or when the subscriber cancels the delivery, or when a new message arrives after 84 delivery status messages have been stored in the subscriber's mailbox (the oldest status message is always deleted first).</p>	<ul style="list-style-type: none"> • See 3.2 Checking Mailbox Distribution in the Subscriber's Guide.
Message Reception Mode	<p>allows incoming calls to be received by either a subscriber's regular or interview mailbox.</p> <p>This mode is effective for: (1) Incomplete Call Handling Service (when the subscriber's line is busy, or he cannot take the call, or when he has enabled Call Blocking), and (2) when the transfer destination of calls is set to a Logical Extension.</p>	<ul style="list-style-type: none"> • See "Interview Service" and "Logical Extension (All Calls Transfer to Mailbox)" in this Table. • See "All Calls Transfer to Mailbox" in Table 36 in B2 SYSTEM ADMINISTRATION—MAILBOXES. • See 4.4 Message Reception Mode in the Subscriber's Guide.
Message Scan	<p>permits the subscriber to scan the first 4 s of each message. The subscriber can replay the previous message, play the next message, or play the entire message.</p>	<ul style="list-style-type: none"> • See "Message Scanning with Information" in Table 39 in B3 SYSTEM ADMINISTRATION—SETTING COS (CLASS OF SERVICE) PARAMETERS. • See C3 SETTING COS (CLASS OF SERVICE) PARAMETERS. • See "Scanning Messages" in Glossary. • See 2.1 Receiving Messages in the Subscriber's Guide.

Table 33

FEATURE	DESCRIPTION	REFERENCES
Message Transfer	<p>allows the subscriber to transfer messages to other mailboxes after playing. The subscriber can also add a personal comment at the beginning of the message to be transferred if desired.</p> <p>One or more individual mailboxes can be specified for message transfer. Messages can also be transferred using either the System or Personal Group Distribution Lists.</p>	<ul style="list-style-type: none"> • See "Transferring Messages" in D2 MANAGING THE GENERAL DELIVERY MAILBOX. • See "Message Transfer" in Glossary. • See 2.3 Message Transfer in the Subscriber's Guide.
Message Waiting Notification— Device	<p>automatically notifies the subscriber/Message Manager of the reception of new message(s) by calling either a specified telephone or beeper number. The message will automatically play when the subscriber/Message Manager answers a call to the telephone. When a beeper is called, the subscriber/Message Manager must call the VPS and access the message from the mailbox. Notification can be scheduled either on or off for a maximum of 2 times during any 24 h period.</p> <p>The subscriber/Message Manager can program a maximum of 3 telephones or beepers in sequence. The VPS will recall the number or number sequence for a specified number of times until answered.</p> <p>Notification is terminated when the subscriber/Message Manager has received the message, when the last number has been called a specified number of times, or at the completion of the programmed time period.</p>	<ul style="list-style-type: none"> • See "Message Waiting Notification from an SLT" in 3.1.4 PBX Requirements for Integration. • See "Notification Setting" in B2 SYSTEM ADMINISTRATION—MAILBOXES. • See "Authorization for Message Notification" in Tables 39 and 40 in B3 SYSTEM ADMINISTRATION—SETTING COS (CLASS OF SERVICE) PARAMETERS. • See "Other Parameters-Message Waiting Notification" in B6.7 Other Parameters. • See C3 SETTING COS (CLASS OF SERVICE) PARAMETERS. • See D3 SETTING UP MESSAGE WAITING NOTIFICATION. • See "Message Waiting Notification" in Glossary. • See 4.8 Message Waiting Notification in the Subscriber's Guide.

Table 33

FEATURE	DESCRIPTION	REFERENCES
Message Waiting Notification—Lamp	<p>automatically illuminates the message waiting lamp on the subscriber's or the Message Manager's telephone when there are unplayed messages waiting in the mailbox.</p> <p>Note: The extension assigned for Operator 1 in the Day Mode is the Message Manager's telephone. However, its default extension number (0) cannot be used with this feature. When using this feature, you must assign the extension number that is included in the Extension Numbering Plan.</p>	<ul style="list-style-type: none"> • See "Message Waiting Notification from an SLT" in 3.1.4 PBX Requirements for Integration. • See 7.2.13 Message Waiting Lamp Retry Times (MWL). • See "MWL Notification for Unreceived Message" in Tables 39 and 40 in B3 SYSTEM ADMINISTRATION—SETTING COS (CLASS OF SERVICE) PARAMETERS. • See "Other Parameters-Message Waiting Notification" in B6.7 Other Parameters. • See C3 SETTING COS (CLASS OF SERVICE) PARAMETERS. • See D3 SETTING UP MESSAGE WAITING NOTIFICATION. • See "Message Waiting Lamp" in Glossary. • See 4.8 Message Waiting Notification in the Subscriber's Guide.
Multilingual Service	<p>permits up to 3 languages to be used for prompt options. If the "Selective" mode is selected, callers are able to choose their desired language.</p>	<ul style="list-style-type: none"> • See "Incoming Call Service Prompt" in Table 22 in 5.3.1 Port Service Menu. • See "System/User 1/User 2 Selection Number" in Table 58 in B6.5 Prompt Setting. • See "Recording Menus and Voice Labels" and "Recording User Prompts" in D6 RECORDING MESSAGES. • See "Multilingual Selection Menu" in Glossary.

Table 33

FEATURE	DESCRIPTION	REFERENCES
No Answer Coverage Mode	<p>specifies how the calls will be handled when Operator 1, 2 and/or 3 do not answer them within the specified "Operator No Answer Time". There are 4 options:</p> <p>Caller Select*¹—caller may leave a message or call another extension.</p> <p>Leave Message*¹—caller may leave a message in Operators' mailbox.</p> <p>Disconnect Message*¹—caller is disconnected from the VPS after hearing "<i>Thank you for calling.</i>"</p> <p>Next Operator*²—caller is transferred to the next operator (Operator 2 or 3) extension.</p> <p>*1: Assignable for Operator 1, 2 and 3 *2: Assignable for Operator 1 and 2</p>	<ul style="list-style-type: none"> • See "No Answer Coverage Mode" in Table 23 in 5.4.3 Operator's Parameters. • See "No Answer Coverage Mode" in Tables 44, 45 and 46 in B5.1 Automated Attendant Parameters.
Operator Service	<p>permits callers to request a live operator by pressing [0] on the telephone keypad. Up to 3 operators can be specified to receive calls in the Day, Night, Lunch and Break Modes.</p>	<ul style="list-style-type: none"> • See 5.4.3 Operator's Parameters. • See "Operator's Parameters" in B5.1 Automated Attendant Parameters. • See "Operator's Extensions" in D4 CUSTOMIZING THE MESSAGE MANAGER'S MAILBOX.
Password Administration	<p>allows the System Administrator or System Manager to clear a subscriber password (so that a new one can be assigned).</p>	<ul style="list-style-type: none"> • See 5.5.4 Password Reset. • See "Deleting a Mailbox Password" in C2 SETTING UP MAILBOXES.
PBX Integration	<p>allows the VPS and PBX to work together as an integrated unit. Three integration options are available: Inband Integration, APT Integration and DPT Integration.</p>	<ul style="list-style-type: none"> • See 2.7 CONNECTIONS. • See Section 3 INTEGRATING THE VPS WITH PANASONIC KX-T PHONE SYSTEMS. • See Section 4 INTEGRATING THE VPS WITH THE PANASONIC KX-TA SERIES PBX AND KX-TD SERIES PBX.

Table 33

FEATURE	DESCRIPTION	REFERENCES
Personal Greeting for Caller ID (APT/DPT Integration Only)	<p>permits subscribers to record up to 4 personal greetings for calls from pre-assigned Caller ID numbers. Each greeting supports up to 8 caller ID numbers.</p> <p>This feature can be enabled or disabled in the COS (Class of Service) settings.</p>	<ul style="list-style-type: none"> • See 4.1 GUIDELINES FOR DIGITAL INTEGRATION. • See "Personal Greeting Length" and "Personal Greeting for CID" in Table 39 in B3 SYSTEM ADMINISTRATION—SETTING COS (CLASS OF SERVICE) PARAMETERS. • See C3 SETTING COS (CLASS OF SERVICE) PARAMETERS. • See "Personal Greeting for Caller ID" in Glossary. • See 4.10 Recording Personal Greetings for Caller ID in the Subscriber's Guide. • See 4.11 Assigning Caller ID Numbers for Personal Greeting for Caller ID in the Subscriber's Guide.
Personal Greetings	<p>permit the subscriber to record the following 3 personal message greetings:</p> <p>No Answer—Plays when unavailable to answer the call during business hours.</p> <p>Busy Signal—Plays whenever the line is busy.</p> <p>After Hours—Plays when the VPS is in the Night Mode.</p> <p>The No Answer Greeting will also play:</p> <ul style="list-style-type: none"> • when the caller accesses the mailbox directly. • when the Busy Signal or the After Hours Greeting has not been recorded. 	<ul style="list-style-type: none"> • See 6.2.1 Recording Personal Greetings. • See "Personal Greeting Length" in Table 39 in B3 SYSTEM ADMINISTRATION—SETTING COS (CLASS OF SERVICE) PARAMETERS. • See C3 SETTING COS (CLASS OF SERVICE) PARAMETERS. • See "Personal Greetings" in Glossary. • See 1.2 Recording Personal Greetings in the Subscriber's Guide.

Table 33

FEATURE	DESCRIPTION	REFERENCES
Play System Prompt After Personal Greeting	allows the "Guidance for Recording" message to be played for the caller after the "Personal Greeting". The "Guidance for Recording" message instructs the caller how to terminate the call, access more features, and rerecord the message.	<ul style="list-style-type: none"> • See "Play System Prompt after Personal Greeting" in Table 39 in B3 SYSTEM ADMINISTRATION—SETTING COS (CLASS OF SERVICE) PARAMETERS. • See C3 SETTING COS (CLASS OF SERVICE) PARAMETERS.
Port Service	<p>allows assignment of call services to each port.</p> <p>The incoming call service determines which service is used when answering incoming calls. These services include: Voice Mail Service, Automated Attendant Service, Interview Service and Custom Service.</p>	<ul style="list-style-type: none"> • See 5.2 PORT SETTING OPTIONS. • See B4 SYSTEM ADMINISTRATION—PORT/TRUNK SERVICE.
Private Message	allows a subscriber and the System Manager to specify a message as "Private" when sending it to other subscribers, the Message Manager and/or the System Manager. A message specified as "Private" cannot be transferred. It is also possible to specify messages recorded in the Voice Mail Service as "Private".	<ul style="list-style-type: none"> • See "Delivering Messages to Specified Mailboxes" in C7 DELIVERING MESSAGES. • See "Private Message" in Glossary. • See 3.1 Delivering Messages to Other Subscribers in the Subscriber's Guide.
Receive Message	<p>allows subscribers to access messages left in their mailboxes. Three options are available to subscribers:</p> <p>Reply to Message Sender—permits subscribers to reply to the message sender without specifying the extension.</p> <p>Message Transfer—permits subscribers to transfer their messages to other mailboxes.</p> <p>Message Scan—permits subscribers to listen to the first 4 s of each message.</p>	<ul style="list-style-type: none"> • See "Message Transfer" and "Message Scan" in this Table. • See 2.1 Receiving Messages in the Subscriber's Guide. • See 2.2 Replying to Messages in the Subscriber's Guide.

Table 33

FEATURE	DESCRIPTION	REFERENCES
Remote Call Forwarding Set (DPT Integration only)	<p>allows a subscriber and the Message Manager to program his extension from a remote location to forward various types of calls to a desired extension or an outside telephone.</p> <p>There are 6 forwarding settings available:</p> <p>FWD All—Forward all incoming calls to a desired extension number.</p> <p>FWD Busy—Forward all incoming calls to a desired extension number when the line is busy.</p> <p>FWD No Answer—Forward all incoming calls to a desired extension number when there is no answer.</p> <p>FWD Busy or No Answer—Forward all incoming calls to a desired extension number when the line is busy or there is no answer.</p> <p>FWD to CO*—Forward all incoming calls to the Telephone number 1 or 2 (programmed in the Mailbox Setting), or to any other number.</p> <p>FWD Cancel—Cancel the forwarding setting.</p> <p>*: Must be enabled in the COS (Class of Service) settings to be utilized.</p> <p>With respect to PBX programming, it is possible that "Call Forward to CO" is disabled. To enable VPS Remote Call Forwarding, the KX-TD1232, for example, must be programmed properly. For the COS of the extensions whose calls are to be forwarded to a CO line, enable the following: [504] Call Forward to Outside Line.</p> <p>Note: The extension assigned for Operator 1 in the Day Mode is the Message Manager's extension. However, its default extension number (0) cannot be used with this feature. When using this feature, you must assign the extension number that is included in the Extension Numbering Plan.</p>	<ul style="list-style-type: none"> • See 5.5.2 Entering a Mailbox. • See "Remote Call Forward to CO Setting" in B2 SYSTEM ADMINISTRATION—MAILBOXES. • See "Remote Call Forward to CO" in Tables 39 and 40 in B3 SYSTEM ADMINISTRATION—SETTING COS (CLASS OF SERVICE) PARAMETERS. • See C3 SETTING COS (CLASS OF SERVICE) PARAMETERS. • See D7 REMOTE CALL FORWARDING SET. • See "Remote Call Forwarding Set" in Glossary. • See 4.16 Remote Call Forwarding Set in the Subscriber's Guide.

Table 33

FEATURE	DESCRIPTION	REFERENCES
Rotary Telephone Service	provides guidance to callers using rotary telephone systems or when several seconds pass without anything being entered by the caller.	<ul style="list-style-type: none"> • See "Other Parameters-Rotary Telephone Service" in B6.7 Other Parameters. • See "Rotary Telephone" in Glossary.
Service Access Commands	<p>allow the caller to directly access several standard features.</p> <p><i>(0) to repeat the Help Menu or call the operator</i></p> <p><i>(*) to return to previous menu</i></p> <p><i>(#) (1) to dial by name</i></p> <p><i>(#) (3) Department Dialing</i></p> <p><i>(#) (5) Login</i></p> <p><i>(#) (6) Voice Mail Service</i></p> <p><i>(#) (7) to restart (Subscriber's main menu)</i></p> <p><i>(#) (8) to call transfer</i></p> <p><i>(#) (9) to exit</i></p>	<ul style="list-style-type: none"> • See 5.2.6 Voice Mail. • See 5.2.10 Automated Attendant. • See 1.5 Service Access Commands in the Subscriber's Guide.
Service Mode	<p>allows the System Administrator or the System Manager to change the call handling method that is programmed in the Time Service setting.</p> <p>Once the Service Mode has been changed, it is retained unless the System Manager or System Administrator changes it again, even after the power turns off.</p> <p>There are 6 Service Modes available:</p> <p>Automatic Mode—Operates according to the setting in Time Service.</p> <p>Manual Day Mode—Operates only in Day Mode.</p> <p>Manual Night Mode—Operates only in Night Mode.</p> <p>Manual Lunch Mode—Operates only in Lunch Mode.</p> <p>Manual Break Mode—Operates only in Break Mode.</p> <p>PBX Control Mode—Operation changes depending on PBX time period (APT/DPT Integration only).</p>	<ul style="list-style-type: none"> • See "Time Service" in this Table. • See "Time Service-Service Mode" in B6.2 Time Service. • See C5 CHANGING THE SERVICE MODE SETTING.

Table 33

FEATURE	DESCRIPTION	REFERENCES
Special Feature Authorization	<p>permits mailbox owners to use the following special features: Remote Call Forward to CO, Delete Message Confirmation, Message Waiting Notification, External Message Delivery, and Auto Forwarding.</p> <p>But the Message Manager can only utilize the following features: Remote Call Forward to CO, Delete Message Confirmation, and Message Waiting Notification; and the System Manager can only utilize the Delete Message Confirmation feature.</p>	<ul style="list-style-type: none"> • See "Remote Call Forward to CO", "Delete Message Confirmation", "Authorization for Message Notification", "Authorization for External Message Delivery", and "Authorization for Auto Forwarding" in Table 39 in B3 SYSTEM ADMINISTRATION—SETTING COS (CLASS OF SERVICE) PARAMETERS. • See "Remote Call Forward to CO", "Delete Message Confirmation", and "Authorization for Message Notification" in Table 40 in B3 SYSTEM ADMINISTRATION—SETTING COS (CLASS OF SERVICE) PARAMETERS. • See C3 SETTING COS (CLASS OF SERVICE) PARAMETERS.
System Clock	allows the correct setting of the date and time to be made for proper VPS operation.	<ul style="list-style-type: none"> • See 7.2.4 Set Time (TIME). • See C4 SETTING THE SYSTEM CLOCK. • See D5 SETTING THE SYSTEM CLOCK.
System Reports	Eight System Reports are available to the System Administrator and System Manager to monitor VPS operating status. These reports include: Mailbox Assignments, COS Assignments, System Service Report, Call Account Report, Port Usage Report, Flash Memory Usage Report, Mailbox Usage Report, and the Fax Call Report.	<ul style="list-style-type: none"> • See 7.3 SYSTEM REPORTS. • See C6 CHECKING SYSTEM USAGE (SYSTEM REPORTS). • See "System Report" in Glossary.

Table 33

FEATURE	DESCRIPTION	REFERENCES
Time Service	is a timer function that initiates the appropriate call handling method depending on the time of day: Day, Night, Lunch, and Break Service periods.	<ul style="list-style-type: none"> • See "Service Mode" in this table. • See "Time Service (1-5-2-2)" in 5.2.2 Custom Service Features. • See "Time Service-Time Service" in B6.2 Time Service.
Time Synchronization (DPT Integration only)	occurs between the VPS and PBX when the PBX sets a new date and time, or when DPT Integration is established. The date and time are automatically sent from the PBX to the VPS.	<ul style="list-style-type: none"> • See 4.1 GUIDELINES FOR DIGITAL INTEGRATION. • See 7.2.4 Set Time (TIME). • See "Time Synchronization" in Glossary.
Trunk Service (Universal Port) (APT/DPT Integration only)	<p>allows call services to be assigned to each trunk (CO line) group.</p> <p>The incoming call service determines which service is used when answering incoming calls. These services include: Voice Mail Service, Automated Attendant Service, Interview Service and Custom Service.</p>	<ul style="list-style-type: none"> • See 4.1 GUIDELINES FOR DIGITAL INTEGRATION. • See B4 SYSTEM ADMINISTRATION—PORT/TRUNK SERVICE.
Two-Way Recording (APT/DPT Integration only)	permits a subscriber to record two-way conversations into his mailbox.	<ul style="list-style-type: none"> • See 4.1 GUIDELINES FOR DIGITAL INTEGRATION. • See 4.4.8 Two-Way Recording Button Assignment via Station Programming. • See 4.4.13 Two-Way Recording into Mailbox. • See "Two-Way Recording" in Glossary. • See 4.14 Recording a Two-Way Conversation in the Subscriber's Guide.

Table 33

FEATURE	DESCRIPTION	REFERENCES
Two-Way Transfer (APT/DPT Integration only)	permits a subscriber to record two-way conversations into another person's mailbox.	<ul style="list-style-type: none"> • See 4.1 GUIDELINES FOR DIGITAL INTEGRATION. • See 4.4.9 Two-Way Transfer Button Assignment via Station Programming. • See 4.4.14 Two-Way Transfer into Mailbox. • See "Two-Way Transfer" in Glossary. • See 4.14 Recording a Two-Way Conversation in the Subscriber's Guide.
Unlimited Message Length	permits a mailbox owner to record two-way conversations of unlimited length into his or another person's mailbox (Two-Way Recording or Two-Way Transfer). The maximum recording time for other messages will automatically be set to 6 min. To allow unlimited recording time, the "Message Length" parameter must be set to "0: Unlimited" in the COS (Class of Service) settings.	<ul style="list-style-type: none"> • See "Two-Way Recording" and "Two-Way Transfer" in this table. • See "Message Length" in Tables 39 and 40 in B3 SYSTEM ADMINISTRATION—SETTING COS (CLASS OF SERVICE) PARAMETERS. • See C3 SETTING COS (CLASS OF SERVICE) PARAMETERS. • See "Unlimited Message Length" in Glossary.
Utility Commands	allow the System Administrator to access critical VPS functions.	<ul style="list-style-type: none"> • See 7.2 UTILITY COMMANDS.
Voice Mail Service	permits a caller/non-subscriber to leave a message in any mailbox.	<ul style="list-style-type: none"> • See 5.2.6 Voice Mail. • See B4 SYSTEM ADMINISTRATION—PORT/TRUNK SERVICE. • See "Voice Mail" in Glossary.

Table 33

FEATURE	DESCRIPTION	REFERENCES
Voice Prompts	<p>are announcements that instruct the caller.</p> <p>There are 3 kinds of voice prompts:</p> <p>(1) System Prompts (recorded at the factory in English),</p> <p>(2) User 1 Prompts (not recorded), and</p> <p>(3) User 2 Prompts (not recorded)</p>	<ul style="list-style-type: none"> • See 6.1.4 Customizing User Prompts (Enter #6*998,5,6). • See " Prompt Mode" in Tables 39 and 40 in B3 SYSTEM ADMINISTRATION— SETTING COS (CLASS OF SERVICE) PARAMETERS • See B6.5 Prompt Setting. • See C3 SETTING COS (CLASS OF SERVICE) PARAMETERS. • See "Recording User Prompts" in D6 RECORDING MESSAGES. • See "Voice Prompt" in Glossary.

Appendix B
SYSTEM ADMINISTRATOR'S GUIDE

B1 SYSTEM NAVIGATION

Use either a VT or RS-232C terminals (ASCII Terminals) to perform System Administration, which includes the setting and changing of system parameters. This can be a personal computer with emulation software.

Keyboard Use

RS-232C Terminals (ASCII Terminals)

When using RS-232C Terminals, **Type** the number of the option desired and **Press RETURN** to choose menu options.

Table 34

KEY	FUNCTIONS
(1)-(9), then (RETURN)	<i>Typing any number 1 through 9 will select the corresponding option for that number. Pressing RETURN will select the number entered.</i>
(\)	<i>Exits the current screen and returns to the previous step within the menu.</i>
Backspace	<i>Used to correct any mis-typed entry.</i>

Using the Interface

Programming Guidance

Each parameter is accessed through a series of menu screens. The Programming Menu Structure Diagram provided below depicts this menu flow. A menu flow that corresponds to the Programming Menu Structure Diagram is given at the beginning of each section. This flow is designed to guide the user through the appropriate menus to the parameter to be setup or changed. The following example illustrates how the menu flow is used.

Example:

System Administration Top Menu - 1 - 4 - 1 - 1

- 1. Press 1** at the System Administration Top Menu. **Press RETURN.**
- 2. Press 4** at the Program Menu. **Press RETURN.**
- 3. Press 1** at the Service Setting Menu. **Press RETURN.**
- 4. Press 1** on the Automated Attendant Menu to select "1. Department Dialing," when selected.
- 5. Press RETURN.** Auto. Attn-Department Dialing Menu will be displayed on the terminal.

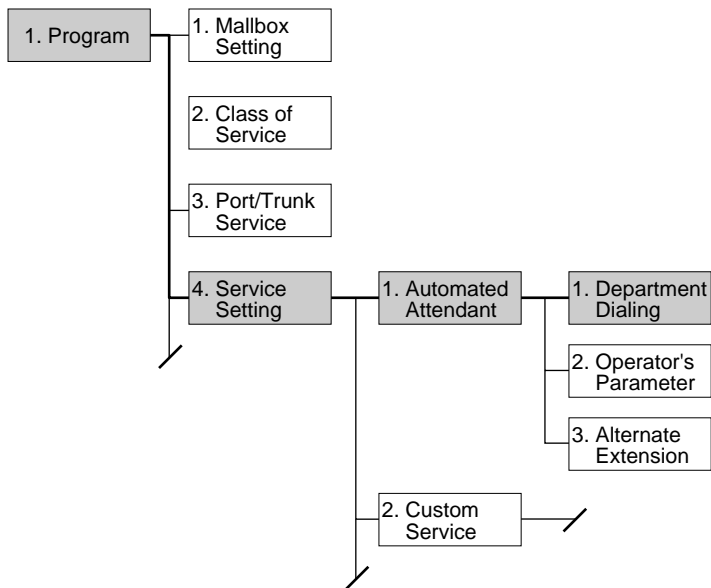

Programming Menu Structure Diagram

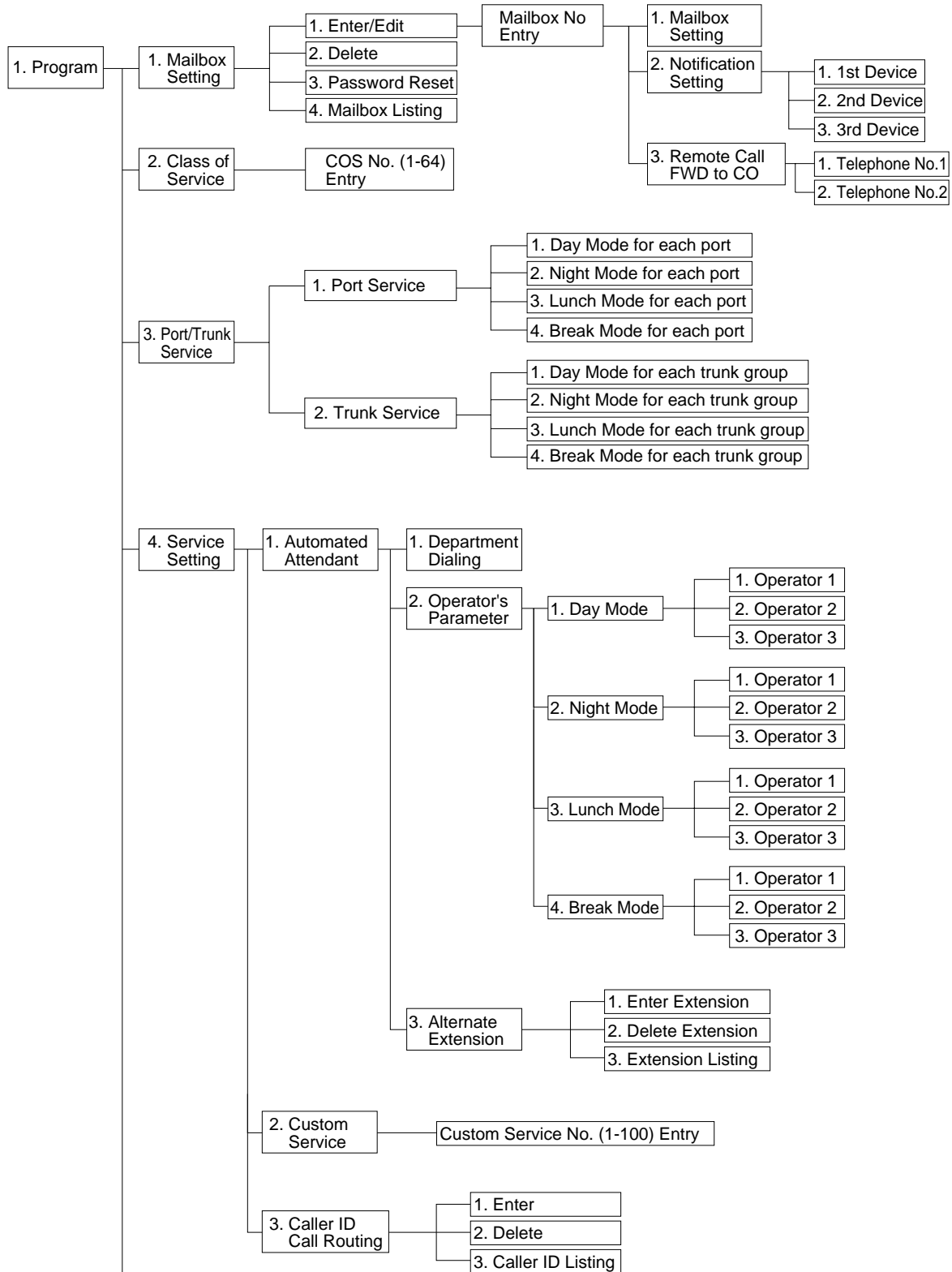

Continued Next Page

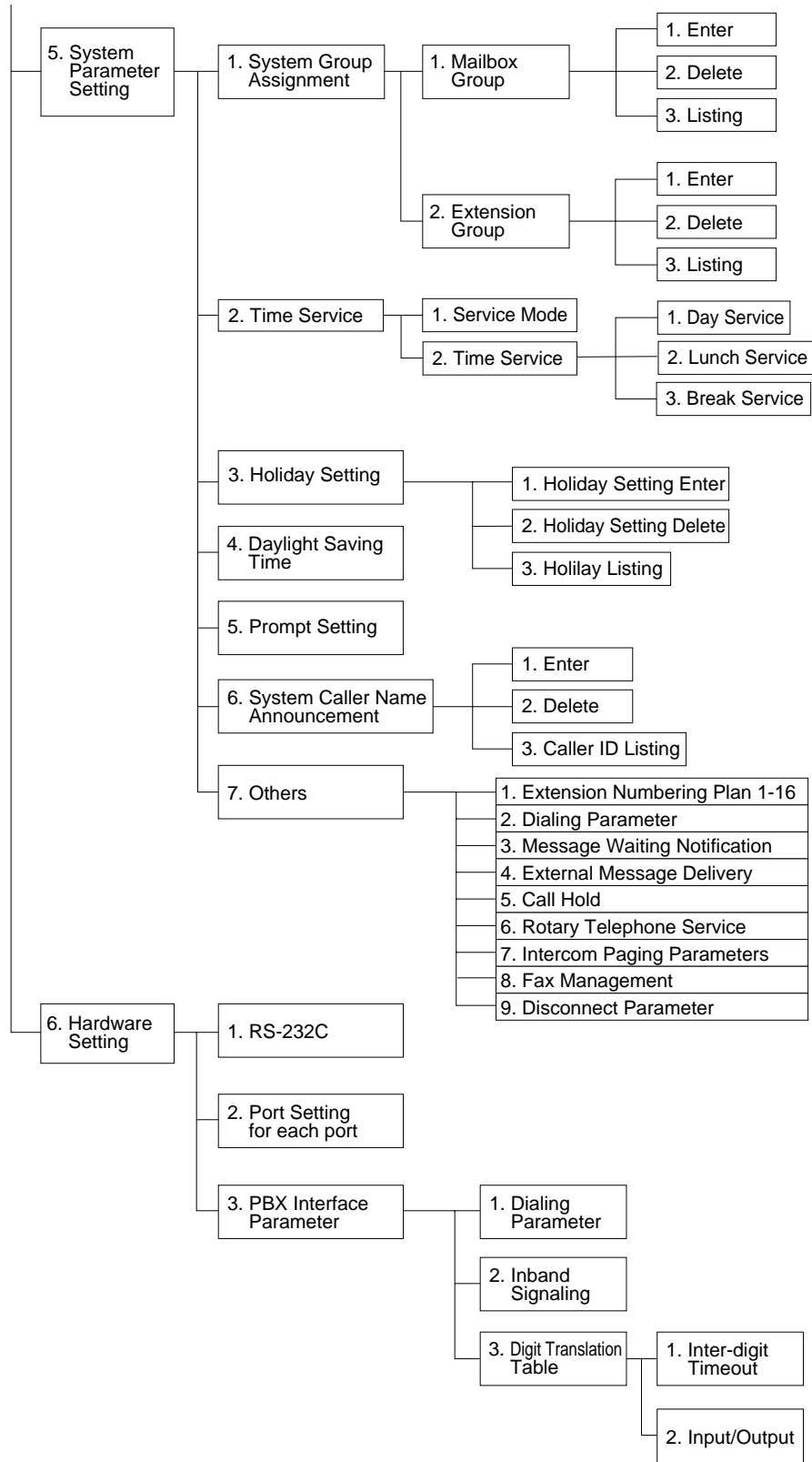

B2 SYSTEM ADMINISTRATION—MAILBOXES

Up to 62 Subscriber Mailboxes can be created or edited by following the correct sequence of steps.

To access the proper menu for mailbox setup, follow the menu path as shown:

System Administration Top Menu-1-1-1-Mailbox No.

Table 35

Parameter	Value Range (Default)	Description/Function
Mailbox Number	2-5 digits (None)	Specifies the subscriber's mailbox number. Mailbox number length is determined during setup or when initializing the system. Mailbox numbers cannot begin with "0". If the length of the mailbox number has been defined as 3 digits, for example, the valid range for all mailbox numbers would be 100 through 997 (998 and 999 would be reserved for the Message Manager and the System Manager). The length of the mailbox number cannot be changed through the Mailbox Setting screen once it has been specified.

Editing Mailboxes

The parameters of each mailbox can be edited based upon the needs of the subscriber.

To access the proper menu for mailbox editing, follow the menu path as shown:

System Administration Top Menu-1-1-1-Mailbox No.-1

Table 36

Parameter	Value Range (Default)	Description/Function
The Extension of the Owner	2-5 digits (None)	Used to transfer calls through the VPS to a subscriber's mailbox. Any valid extension number including an Extension Group List number can be assigned. Note: If an Extension Group List number is assigned to a mailbox, all group members are able to share the information stored there.
Owner First Name	Up to 16 alphabetic characters (None)	The first 4 letters of both the first and last name is printed on the Mailbox Assignments report.
Owner Last Name		The Dialing by Name feature uses the last name.
Class of Service No.	COS No.1-62 (1)	Used to define the set of services available to the subscriber. Note 1: We recommend that parameters for each COS number be defined before assigning a Class of Service (COS) number. Note 2: COS No.63 pertains to the Message Manager while COS No.64 pertains to the System Manager. These numbers cannot be entered in the COS No. data field.
Covering Extension	2-5 digits (None)	Identifies the extension number that will receive unanswered subscriber calls. The Automated Attendant Service accomplishes this call transfer. The caller is given the option of transferring the call or leaving a message in the subscriber's mailbox. The Covering Extension is one of the Incomplete Call Handling Service options that can be enabled or disabled by the subscriber using the telephone keypad. Note: The Extension Group List or Logical Extension Numbers cannot be assigned as covering extensions.

Table 36

Parameter	Value Range (Default)	Description/Function
Interview Mailbox Number	2-5 digits (None)	Permits a mailbox owner to own an interview mailbox. The interview mailbox number must be an unassigned mailbox number. Note: The replies to an interview session constitute one message. If the subscriber expects many interview messages, "Mailbox Capacity Maximum Messages" (see Table 39 in B3 SYSTEM ADMINISTRATION—SETTING COS (CLASS OF SERVICE) PARAMETERS) should be raised to a higher value. Possibly, the subscriber should be assigned to a different COS.
All Calls Transfer to Mailbox	1. Yes 2. No (No)	If this parameter is set to "Yes", all calls routed to the extension are automatically forwarded to the extension's mailbox without ringing the telephone. Forwarding is accomplished through the Automated Attendant service. Callers are permitted to leave a message. Note: When this feature has been set to "Yes", the mailbox owner's extension does not necessarily need to exist as a phone extension of the PBX.

Notification Setting

Follow the procedure below to set the parameters for the Message Waiting Notification Device feature. A maximum of 3 destinations (Device 1, 2, 3) can be specified per mailbox.

- *Class of Service programming determines if the subscriber is able to use this feature.*
- *If the destination device is a telephone, the subscriber will be called when he has message(s), and will have a chance to listen to the message(s).*
- *If the destination device is a beeper, the subscriber will be notified when he has message(s). If the beeper has a display, it is possible to send to it a callback number. The caller can enter the callback number when he leaves a message. If he does not enter a callback number, either the System Callback No., or the caller's number if it is received through a telephone company's Caller ID service, will be sent instead.*

To access the proper menu for Message Waiting Notification, follow the menu path as shown:

System Administration Top Menu-1-1-1-Mailbox No.-2-Device No. 1, 2, or 3.

Notification Setting-Device 1, 2, or 3

Table 37

Parameter	Value Range (Default)	Description/Function
Dial Number	Up to 32 digits consisting of 1-9, 0, *, # P, T, M, X (None)	<p>Assigns a telephone or beeper number to Device 1, 2, or 3. The subscriber can also specify the dial number from his telephone.</p> <p>P: Pause T: Dial Tone Detection M: Dial Mode Switching Code (Touchtone to Pulse, or Pulse to Touchtone) X: Callback Number Entry Code 1-9, 0, *, #: Dial Codes</p> <p>Note: The callback number entry code "X" must be included in the number to be called if the Beeper Callback No. Entry Mode is enabled through COS and "Type of Device" is set to "Beeper". The proper number of "Pauses" must be inserted before the callback entry code.</p> <p>Important Note: When the VPS calls to an outside line via a PRI (ISDN Primary Rate Access Interface) card of a Panasonic PBX, please be sure to add "#" after the telephone number (1112223333 in the example here): <i>Example:</i> 9P1112223333#PP123PP456PPX# Please contact your System Administrator for more explanation.</p>
Type of Device	1. Telephone 2. Beeper (Telephone)	Specifies the device to receive notification. This is automatically set to "Beeper" when "X" is used in the Dial Number (above). The subscriber can also specify the type of device from his telephone.
Use Mode	1. Not Use 2. Continuously 3. Scheduled (Continuously)	<p>Specifies how Device 1, 2, or 3 is to be used. The subscriber can also specify the use mode from his telephone.</p> <p>1. Not Use—Device 1, 2, or 3 is not used for a notification call. 2. Continuously—Device 1, 2, or 3 is called whenever a message is recorded in the mailbox. 3. Scheduled—Device 1, 2, or 3 is called on a schedule basis when a message has been left in the mailbox.</p>

Table 37

Parameter	Value Range (Default)	Description/Function
No. of Retries	0-9 times (0)	Specifies the number of times that a notification call to Device 1, 2, or 3 should be attempted after a busy or no answer condition is received.
Busy Delay Time	0-120 min (3)	Specifies the time (in minutes) the VPS must wait after a busy condition is received before making another notification call to Device 1, 2, or 3.
No Answer Delay Time	60-120 min (60)	Specifies the time (in minutes) the VPS must wait after a no-answer condition is received before making another notification call to Device 1, 2, or 3.
Time Frame 1, 2 MON: TUE: WED: THU: FRI: SAT: SUN:	1-12: h 00-59: min AM/PM: a.m./p.m. *: All Day Space: No Use (No Use)	Specifies the daily schedule for the Message Waiting Notification service for 1 week for this device. Note: These parameters are active only when "Use Mode" is set to "Scheduled".

Remote Call Forward to CO

Follow the procedure below to specify the destination outside telephone number(s) to which the callers are forwarded when the Remote Call Forwarding feature is set to an outside (CO) line.

Telephone number 1 and Telephone number 2 can be specified per mailbox.

- *Class of Service programming determines if the mailbox owner is able to use this feature.*
- *This feature is only available with DPT Integration.*

To access the proper menu for Remote Forward to CO, follow the menu path as shown:

System Administration Top Menu-1-1-1-Mailbox No.-3-Telephone Number 1 or 2.

Table 38

Parameter	Value Range (Default)	Description/Function
Telephone Number 1, 2	Up to 16 digits (With the KX-TD816/TD1232/TA1232) (None)	Specifies the telephone number to which the callers are forwarded when Remote Call Forwarding is set to a CO line. The telephone number can contain the digits "0-9" and "*". The telephone number should begin with a Line Access Code (to seize a CO line). Note: Pressing [(back space)] will clear the parameter.

Deleting a Mailbox

When a mailbox is deleted, the Voice Processing System erases all messages in the mailbox, removes the mailbox from all group distribution lists, deletes the personal group distribution lists assigned to the mailbox, erases the subscriber's name, and cancels all external delivery messages.

To access the proper menu for Deleting a Mailbox, follow the menu path as shown:

System Administration Top Menu-1-1-2-Mailbox No.

Resetting a Mailbox Password

Follow the procedure below to set the parameters for clearing a mailbox password.

To access the proper menu for clearing a mailbox password, follow the menu path as shown:

System Administration Top Menu-1-1-3-Mailbox No.

Listing Mailboxes

Follow the procedure below to display the mailbox number list.

To display the list of all mailbox numbers, follow the menu path as shown:

System Administration Top Menu-1-1-4

B3 SYSTEM ADMINISTRATION—SETTING COS (CLASS OF SERVICE) PARAMETERS

The COS-Class of Service parameters define the set of services that are available to mailbox owners. A maximum of 64 (1-64) classes can be specified. A class of service number can be assigned for each mailbox. More than 1 subscriber can share the same class of service.

- *COS number 63 is only available to the Message Manager while COS number 64 is only available to the System Manager.*
- *The procedure below determines the utilization of the following special features on a COS basis:*
 - *Remote Call Forward to CO (available for COS numbers 1-63)*
 - *Delete Message Confirmation (available for COS numbers 1-64)*
 - *Message Waiting Notification (available for COS numbers 1-63)*
 - *External Message Delivery (available for COS numbers 1-62)*
 - *Auto Forwarding (available for COS numbers 1-62)*

To access the proper menu for Class of Service Numbers 1-64, follow the menu path as shown:

System Administration Top Menu-1-2-COS No.(1-64)

Note

In Tables 39 and 40, sub-parameters are underlined. These sub-parameters can be assigned only when the corresponding authorization parameter is set to "Yes".

Class of Service Setting

COS Nos. 1-62 (for subscribers)

To access the proper menu for Class of Service Numbers 1-62 for subscribers, follow the menu path as shown:

System Administration Top Menu-1-2-COS No.(1-62)

Table 39

Parameter	Value Range (Default)	Description/Function
Personal Greeting Length	8-60 s in 4 s increments (16)	Defines the maximum length of the personal greeting message that can be recorded by the subscriber. This parameter applies to: <ul style="list-style-type: none"> • Personal greeting on No Answer • Personal greeting on Busy • Personal greeting for After Hours • Personal greeting for Caller ID
New Message Retention Time	1-30 days (5)	Defines the number of days that an unplayed message will remain in the mailbox. The storage period begins the day after the message reception.
Saved Message Retention Time	1-30 days 0: Unlimited (5)	Defines the number of days that a played message will remain in the mailbox. The timing is "refreshed" whenever the message is played back. If "0: Unlimited" is selected, the saved message will remain in the mailbox until erased by the subscriber.
Message Length	1-6 min 0: Unlimited (3)	Defines the maximum message length. If set to "0: Unlimited", a subscriber can record two-way conversations of unlimited length into his or another person's mailbox (Two-Way Recording or Two-Way Transfer). The maximum recording time for other messages will automatically be set to 6 min.
Mailbox Capacity Maximum Messages	5-100 msgs (10)	Specifies the maximum number of (both new and saved) messages that can be stored in a mailbox.
Mailbox Capacity Maximum Message Time	5-100 min 0: Unlimited (10)	Specifies the total number of available minutes for storing (both new and saved) messages in each mailbox.
Message Retrieval Order	1. LIFO 2. FIFO (LIFO)	Specifies the order in which messages will be retrieved (played back for listening). 1. LIFO—Messages are retrieved starting with the most recent. 2. FIFO—Messages are retrieved starting with the oldest.

Table 39

Parameter	Value Range (Default)	Description/Function
Message Scanning with Information	1. Yes 2. No (No)	If set to "Yes", the VPS adds the message sender's name and the recording date and time to the message during the message scan.
Play System Prompt after Personal Greeting	1. Yes 2. No (No)	If set to "Yes", directions for recording a message are given to the caller immediately after the personal greeting has been played. The following guidance messages are played: <i>"To end recording, hang up or press 1 for more features".</i> <i>"To pause and restart recording, press 2".</i>
Use Call Waiting on Busy	1. Yes 2. No (No)	If set to "Yes", the VPS signals the busy extension that another call is waiting. Note: To use Call Waiting on Busy, you must also enable the use of the Call Waiting feature at your PBX.
Message Cancel for Live Call Screening	1. Yes 2. No (Yes)	The Live Call Screening feature permits the subscriber to monitor incoming messages as they are being recorded, or intercept them if desired. If the subscriber chooses to speak to the caller, if not disabled by the PBX beforehand, the VPS will record the two-way conversation. If set to "Yes", the VPS will automatically delete this recording. The two-way conversation may be saved in the mailbox if the PBX allows the conversation to be recorded. If set to "No", the recording will be automatically saved. Note: The Live Call Screening feature is available if APT/DPT Voice Mail Integration is activated with a Panasonic KX-TA624 or other KX-T series telephone system.

Table 39

Parameter	Value Range (Default)	Description/Function
Direct Mailbox Access	1. Yes 2. No (Yes)	<p>If set to "Yes", a subscriber is able to directly enter Subscriber Service. This is accomplished by calling a VPS extension directly from the subscriber's extension. The Subscriber Service Access Code ("*" and mailbox number) need not be dialed. Password entry may be required if specified beforehand.</p> <p>Note: The Direct Mailbox Access feature is available if APT/DPT Voice Mail Integration is activated with a Panasonic KX-TA624 or other KX-T series telephone system.</p>
Intercom Paging Group	1-17 (COS NO.1-9: Group 1-9; COS NO.10-62: Group 1)	<p>Specifies the Intercom Paging group number available to the subscriber.</p> <p>If set to "9", the Intercom Paging feature is activated for all groups.</p> <p>Note: The Intercom Paging feature is available if APT/DPT Voice Mail Integration is activated with a Panasonic KX-TA624 or other KX-T series telephone system.</p>
Prompt Mode	1. System 2. User 1 3. User 2 (User 1)	<p>Specifies the language used for voice prompts played for the subscriber during a Message Waiting Notification Call and Subscriber Service.</p> <p>Note: If User 1 or User 2 is specified as Prompt Mode but not recorded by the Message Manager, the VPS will automatically play the factory-recorded System prompts in English.</p>

Table 39

Parameter	Value Range (Default)	Description/Function
Remote Call Forward to CO	1. Yes 2. No (No)	<p>If set to "Yes", Remote Call Forwarding can be set to an outside (CO) line; a subscriber can program (either from a remote location or on-site) his extension to forward various types of calls to either "Telephone No.1" or "Telephone No.2" (preprogrammed in the Mailbox Setting), or to any other telephone number.</p> <p>Note: The Remote Call FWD to CO feature is available if DPT Voice Mail Integration is activated with a Panasonic KX-T series telephone system.</p> <p>Important Note: With respect to PBX programming, it is possible that "Call Forward to CO" is disabled. To enable VPS Remote Call Forwarding, the KX-TD1232, for example, must be programmed properly. For the COS of the extensions whose calls are to be forwarded to a CO line, enable the following: [504] Call Forward to Outside Line.</p>
Delete Message Confirmation	1. Yes 2. No (No)	If set to "Yes", the VPS requests confirmation from the mailbox owner before erasing a message left in the mailbox. If set to "No", the message is erased immediately.
Number of CIDs for Caller Name Announcement	0-30 (30)	Specifies the maximum number of Caller IDs which subscribers can assign for the Personal Caller Name Announcement.
Personal Greeting for CID	1. Yes 2. No (Yes)	If set to "Yes", subscribers can utilize the personal greeting feature for Caller ID.
Caller ID Screening	1. Yes 2. No (Yes)	If set to "Yes", subscribers can utilize the Caller ID Screening feature.
Authorization for Message Notification	1. Yes 2. No (No)	<p>If set to "Yes", subscribers are able to utilize the Message Waiting Notification feature. The sub-parameters to be set include Beeper Callback No. Entry Mode, MWL Notification for Unreceived Message, and Device Notification for Unreceived Message. If set to "No", sub-parameters cannot be assigned.</p> <p>Note: This parameter in COS No.1 is set to "Yes" when the Quick Setup procedure is used to create Subscriber Mailboxes.</p>

Table 39

Parameter	Value Range (Default)	Description/Function
<u>Beeper</u> <u>Callback</u> <u>No. Entry</u> <u>Mode</u>	1. Caller Select 2. Without 3. Before 4. After 5. Disable (Disable)	Permits subscribers to use the Callback Number Entry feature. Caller Select: After recording a message, the caller is asked if the message is urgent. If urgent, the caller is asked to enter the callback number. Without: Without recording a message, the caller is asked to enter the callback number. Before: Before recording a message, the VPS asks the caller to enter the callback number. After: After recording a message, the VPS asks the caller to enter the callback number. Disable: Disables the Callback Number Entry feature. Note: To utilize this feature, the callback number entry code must be included in the subscriber's beeper number. When "Disable" is selected or if the caller does not enter a callback number, "System Callback No." (see Table 62) will be displayed on the beeper's display. If a caller's number is received through a telephone company's Caller ID service, the caller's number will be displayed instead of "System Callback No.".
<u>MWL</u> <u>Notification for</u> <u>Unreceived</u> <u>Message</u>	1. Yes 2. No (Yes)	If set to "Yes", the message waiting lamp will illuminate when unplayed messages remain after the subscriber has accessed the mailbox for Subscriber Service.
<u>Device</u> <u>Notification for</u> <u>Unreceived</u> <u>Message</u>	1. Yes 2. No (No)	If set to "Yes", the VPS calls the appropriate device in numerical order until all unplayed messages are received.
Authorization for External Message Delivery	1. Yes 2. No (No)	If set to "Yes", subscribers are able to utilize the External Message Delivery feature. The sub-parameter to be set is Prompt Mode. If set to "No", sub-parameter cannot be assigned.

Table 39

Parameter	Value Range (Default)	Description/Function
<u>Prompt Mode</u>	1. System 2. User 1 3. User 2 4. Selective (User 1)	When an external message is delivered, the receiver will be greeted by the VPS in the specified language (prompt). However, if "Selective" is enabled, then the receiver has a choice of prompts. See related explanation in "Incoming Call Service Prompt" in Table 22 in 5.3.1 Port Service Menu. Note: When "Selective" is enabled and the receiver uses a rotary telephone, the no-entry selection is specified by "Prompt for Rotary Callers" in Table 22 in 5.3.1 Port Service Menu.
Authorization for Auto Forwarding	1. Yes 2. No (No)	If set to "Yes", the VPS automatically forwards messages that have not been accessed for a specific length of time to another mailbox. The sub-parameters to be set for this feature include Mailbox Number, Delay Time, and Forwarding Mode. If set to "No", sub-parameters cannot be assigned.
<u>Mailbox Number</u>	2-5 digits (None)	Specifies the mailbox to which the messages will be forwarded. Note: The numbers of the System Group Distribution List cannot be specified as the destination.
<u>Delay Time</u>	(h) (min) 00:05 to 99:59 (00:30)	Specifies the length of time in hours and minutes that the VPS must wait before forwarding unretrieved messages. The maximum delay time is 99 h, 59 min. Note: The delay time must be less than the New Message Retention Time, or else messages will be deleted before being forwarded.
<u>Forwarding Mode</u>	1. Copy 2. Move (Move)	Specifies if forwarded messages are to be retained in the original mailbox. When set to "Copy", copies of the messages are retained in the original mailbox after forwarding. When set to "Move", messages are forwarded to the receiving mailbox and are not retained at the original location.

COS Nos. 63 & 64 (for Managers)

To access the proper menu for Class of Service Numbers 63 & 64 for Managers, follow the menu path as shown:

System Administration Top Menu-1-2-COS No.(63-64)

Only the parameters listed below can be assigned for COS numbers 63 and 64. COS number 64 cannot assign the parameters relating to the Message Waiting Notification and the Remote Call Forward to CO features.

Table 40

Parameter	Value Range (Default)	Description/Function
New Message Retention Time	1-30 days (30)	Defines the number of days that an unplayed message can remain in the mailbox. The storage period begins the day after the message reception.
Saved Message Retention Time	1-30 days 0: Unlimited (30)	Defines the number of days a played saved message will remain in the mailbox. The timing is "refreshed" whenever the message is played back. If "0: Unlimited" is selected, saved messages will remain in the mailbox until erased by the mailbox owner.
Message Length	1-6 min 0: Unlimited (6)	Defines the maximum message length. If set to "0: Unlimited", a manager can record two-way conversations of unlimited length into his or another person's mailbox (Two-Way Recording or Two-Way Transfer). The maximum recording time for other messages will automatically be set to 6 min.
Mailbox Capacity Maximum Messages	5-100 msgs (100)	Specifies the maximum number of (both new and saved) messages that can be stored in a mailbox.
Mailbox Capacity Maximum Message Time	5-100 min 0: Unlimited (100)	Specifies the total number of available minutes for storing (both new and saved) messages in each mailbox.
Message Retrieval Order	1. LIFO 2. FIFO (LIFO)	Specifies the order in which messages will be retrieved (played back for listening). 1. LIFO—Messages are retrieved starting with the most recent. 2. FIFO—Messages are retrieved starting with the oldest.

Table 40

Parameter	Value Range (Default)	Description/Function
Message Scanning with Information	1. Yes 2. No (No)	If set to "Yes", the VPS adds the message sender's name and the recording date and time to the message during the message scan.
Prompt Mode	1. System 2. User 1 3. User 2 (User 1)	Specifies the language used for voice prompts. Note: If User 1 or User 2 is specified as Prompt Mode but not recorded by the Message Manager, the VPS will automatically play the factory-recorded System prompts in English.
Remote Call Forward to CO	1. Yes 2. No (No)	If set to "Yes", Remote Call Forwarding can be set to an outside (CO) line; the Message Manager can program (either from a remote location or on-site) his extension to forward various types of calls to either "Telephone No.1" or "Telephone No.2" (preprogrammed in the Mailbox Setting), or to any other telephone number. Note: The Remote Call FWD to CO feature is available if DPT Voice Mail Integration is activated with a Panasonic KX-T series telephone system. Important Note: With respect to PBX programming, it is possible that "Call Forward to CO" is disabled. To enable VPS Remote Call Forwarding, the KX-TD1232, for example, must be programmed properly. For the COS of the extensions whose calls are to be forwarded to a CO line, enable the following: [504] Call Forward to Outside Line.
Delete Message Confirmation	1. Yes 2. No (No)	If set to "Yes", the VPS requests confirmation from the mailbox owner before erasing a message left in the mailbox. If set to "No", the message is erased immediately.
Authorization for Message Notification	1. Yes 2. No (Yes)	If set to "Yes", the Message Manager is able to utilize the Message Waiting Notification feature. The sub-parameters to be set include Beeper Callback No. Entry Mode, MWL Notification for Unreceived Message, and Device Notification for Unreceived Message. If set to "No", sub-parameters cannot be assigned.

Table 40

Parameter	Value Range (Default)	Description/Function
<u>Beeper Callback No. Entry Mode</u>	1. Caller Select 2. Without 3. Before 4. After 5. Disable (Disable)	Permits the Message Manager to use the Callback Number Entry feature. Caller Select: After recording a message, the caller is asked if the message is urgent. If urgent, the caller is asked to enter the callback number. Without: Without recording a message, the caller is asked to enter the callback number. Before: Before recording a message, the VPS asks the caller to enter the callback number. After: After recording a message, the VPS asks the caller to enter the callback number. Disable: Disables the Callback Number Entry feature. Note: To utilize this feature, the callback number entry code must be included in the subscriber's beeper number. When "Disable" is selected or if the caller does not enter a callback number, "System Callback No." (see Table 62) will be displayed on the beeper's display. If a caller's number is received through a telephone company's Caller ID service, the caller's number will be displayed instead of "System Callback No.".
<u>MWL Notification for Unreceived Message</u>	1. Yes 2. No (Yes)	If set to "Yes", the message waiting lamp illuminates when unplayed messages remain after the Message Manager has accessed the mailbox.
<u>Device Notification for Unreceived Message</u>	1. Yes 2. No (No)	If set to "Yes", the VPS calls the appropriate device in numerical order until all unplayed messages are received.

B4 SYSTEM ADMINISTRATION—PORT/TRUNK SERVICE

One of 4 incoming call services can be assigned to each VPS port and each PBX trunk (CO line) group: Voice Mail, Automated Attendant, Interview, or Custom Service.

Services have this order of priority:

Holiday Service > Caller ID Call Routing > Trunk Service > Port Service
(Holiday Service has the highest priority.)

To access the proper menu for Port/Trunk Service Menu, follow the menu path as shown:

System Administration Top Menu-1-3

B4.1 Port Assignment

To access the proper menu for Day, Night, Lunch or Break Mode for the selected port, follow the menu path as shown:

System Administration Top Menu-1-3-1-Port No.(1-2)

Port (1-2)-Day Mode

To access the proper menu for Day Mode features for the selected port, follow the menu path as shown:

System Administration Top Menu-1-3-1-Port No.(1-2)-1

Note

In Tables 41 and 42, the sub-parameter "Prompt for Rotary Callers" is underlined. This sub-parameter can be assigned only when "Incoming Call Service Prompt" is set to "Selective".

Table 41

Parameter	Value Range (Default)	Description/Function
Incoming Call Service	1. Voice Mail 2. Auto. Attn. 3. Interview 4. Custom (Auto. Attn.)	Specifies one of 4 incoming call services. Note 1: When you specify the Interview Service, one of subscriber's Interview Mailbox numbers should also be specified. Note 2: When you specify the Custom service, one of 100 (1-100) Custom service numbers should also be specified.
Incoming Call Service Prompt	1. System 2. User 1 3. User 2 4. Selective (User 1)	Specifies the language of voice prompts to be played on this port. When set to "Selective", the caller can select the language of his choice, provided the Message Manager has recorded the Multilingual Selection Menu and the System Administrator has specified Prompt Selection Number in "System/User 1/User 2 Prompt Selection Number" in Table 58 in B6.5 Prompt Setting. Note: If "Selective" is specified, you will need to select a prompt available for rotary callers. See "Prompt for Rotary Callers" below.
<u>Prompt for Rotary Callers</u>	1. System 2. User 1 3. User 2 (System)	Specifies which language (System/User 1/User 2) a rotary caller or an External Delivery Message receiver hears when he cannot enter any digit (Prompt Selection Number) after the Multilingual Selection Menu has been played.
Delayed Answer Time	0-60 s (0)	Specifies whether the port answers immediately (0) or with delay (1-60 s).

Port (1-2)-Night Mode

To access the proper menu for Night Mode features for the selected port, follow the menu path as shown:

System Administration Top Menu-1-3-1-Port No.(1-2)-2

Port (1-2)-Lunch Mode

To access the proper menu for Lunch Mode features for the selected port, follow the menu path as shown:

System Administration Top Menu-1-3-1-Port No.(1-2)-3

Port (1-2)-Break Mode

To access the proper menu for Break Mode features for the selected port, follow the menu path as shown:

System Administration Top Menu-1-3-1-Port No.(1-2)-4

B4.2 Trunk Group Assignment

This assignment is effective only with APT/DPT Integration. The trunk (CO line) group numbers range from 1 to 24.

To access the proper menu for Day, Night, Lunch or Break Mode for the selected PBX trunk (CO line) group, follow the menu path as shown:

System Administration Top Menu-1-3-2-Trunk Group No.(1-24)

Notes

- *For KX-TD series, "trunk (CO line) group number" in this section (assignment) means "CO line number".*
- *The maximum number of trunk (CO line) groups depends on the VPS model.*

Trunk (1-24)-Day Mode

To access the proper menu for Day Mode features for the selected PBX trunk (CO line) group, follow the menu path as shown:

System Administration Top Menu-1-3-2-Trunk Group No.(1-24)-1

Note

The maximum number of trunk (CO line) groups depends on the VPS model.

Table 42

Parameter	Value Range (Default)	Description/Function
Incoming Call Service	1. Voice Mail 2. Auto. Attn. 3. Interview 4. Custom 5. None (None)	Specifies one of 4 incoming call services. Note 1: When you specify the Interview Service, one of subscriber's Interview Mailbox numbers should also be specified. Note 2: When you specify the Custom service, one of 100 (1-100) Custom service numbers should also be specified.
Incoming Call Service Prompt	1. System 2. User 1 3. User 2 4. Selective (User 1)	Specifies the language of voice prompts to be played on this trunk (CO line) group. When set to "Selective", the caller can select the language of his choice, provided the Message Manager has recorded the Multilingual Selection Menu and the System Administrator has specified Prompt Selection Number in "System/User 1/User 2 Prompt Selection Number" in Table 58 in B6.5 Prompt Setting. Note: If "Selective" is specified, you will need to select a prompt available for rotary callers. See "Prompt for Rotary Callers" below.
<u>Prompt for Rotary Callers</u>	1. System 2. User 1 3. User 2 (System)	Specifies which language (System/User 1/User 2) a rotary caller or an External Delivery Message receiver hears when he cannot enter any digit (Prompt Selection Number) after the Multilingual Selection Menu has been played.
Delayed Answer Time	0-60 s (0)	Specifies whether the trunk (CO line) group answers immediately (0) or with delay (1-60 s).

Trunk (1-24)-Night Mode

To access the proper menu for Night Mode features for the selected PBX trunk (CO line) group, follow the menu path as shown:

System Administration Top Menu-1-3-2-Trunk Group No.(1-24)-2

Note

The maximum number of trunk (CO line) groups depends on the VPS model.

Trunk (1-24)-Lunch Mode

To access the proper menu for Lunch Mode Features for PBX trunk (CO line) group, follow the menu path as shown:

System Administration Top Menu-1-3-2-Trunk Group No.(1-24)-3

Note

The maximum number of trunk (CO line) groups depends on the VPS model.

Trunk (1-24)-Break Mode

To access the proper menu for Break Mode Features for the selected PBX trunk (CO line) group, follow the menu path as shown:

System Administration Top Menu-1-3-2-Trunk Group No.(1-24)-4

Note

The maximum number of trunk (CO line) groups depends on the VPS model.

B5 SYSTEM ADMINISTRATION—SERVICE SETTINGS

B5.1 Automated Attendant Parameters

The Automated Attendant Service has 3 main functions: Department or Speed Dialing, Operator's Parameters, and Alternate Extension.

To access the proper menu for Automated Attendant Parameters, follow the menu path as shown:

System Administration Top Menu-1-4-1

Department Dialing

Department Dialing is a speed-dialing feature that permits a caller to reach the intended extension by dialing a single digit (1-9).

To access the proper menu for Department Dialing, follow the menu path as shown:

System Administration Top Menu-1-4-1-1

Table 43

Parameter	Value Range (Default)	Description/Function
Department Dialing No.1-9	2-5 digits (None)	Specifies the department extension number. Note 1: The Extension Group List or Logical Extension Numbers cannot be assigned. Note 2: The Message Manager must record the Department Dialing menu.

Operator's Parameters

Use these parameters to specify the operator's (operator 1, 2, 3) extensions and mailboxes, as well as how to treat operator-seeking calls.

Operator's parameters can be individually set for Day, Night, Lunch and Break Modes.

To access the proper menu for Operator's Parameters, follow the menu path as shown:

System Administration Top Menu-1-4-1-2

Operator's Parameters-Day Mode-Operator 1

Use this parameter to enable or disable the Operator Service. It specifies Operator 1's extension and the treatment of the calls transferred to that extension. The extension number assigned for Operator 1 in the Day Mode will be for the Message Manager. When Operator service is enabled, operator-seeking calls first reach Operator 1's extension.

Notes

- *Because the extension number assigned for Operator 1 in the Day Mode is for the Message Manager, you cannot assign this extension to any other mailbox.*
- *By default, the extension number for the Message Manager's extension (assigned for Operator 1 in the Day Mode) is "0". However, the default setting cannot be used with the Message Waiting Notification—Lamp feature and the Remote Call Forwarding Set feature. When using these features, You must assign the extension number that is included in the Extension Numbering Plan.*

To access the proper menu for Operator Parameters-Day Mode-Operator 1, follow the menu path as shown:

System Administration Top Menu-1-4-1-2-1-1

Table 44

Parameter	Value Range (Default)	Description/Function
Operator Service	1. Disable 2. Enable (Enable)	Enables or disables the Operator Service feature. Note: All non-touchtone input calls in Automated Attendant Service will be transferred to the General Delivery Mailbox when the Operator Service is disabled.

Table 44

Parameter	Value Range (Default)	Description/Function
Operator's Extension	1-5 digits (0)	Specifies the extension number for Operator 1. Note 1: The default setting (0) cannot be used with the Message Waiting Notification—Lamp feature. An extension number must be assigned that is included in the Extension Numbering Plan. Note 2: The extension number must not be assigned anywhere else (in particular, the extension must not have a mailbox). Otherwise, you will get an error message.
Operator's Mailbox No.	2-5 digits (998)	Callers to Operator 1 are prompted to leave a message in this mailbox depending upon how the Busy Coverage or No Answer Coverage modes are set.
Operator No Answer Time	10-60 s (30)	When a call to Operator 1, 2, or 3 is not answered within the time set, the VPS will offer other options as defined by the "No Answer Coverage Mode". Note 1: This timer applies to Operator 1, 2, and 3. Note 2: If more than 1 operator is assigned, we recommend to reduce the time on the "Operator No Answer Time" to 15 s.
Busy Coverage Mode	1. Hold 2. No Answer Coverage 3. Call Waiting 4. Disconnect Message (Hold)	Specifies how to handle calls when the Operator 1 extension is busy. 1. Hold—Automatically places the caller on hold and the Operator 1 extension is called again. 2. No Answer Coverage—Offers the option specified by the No Answer Coverage Mode to the caller. 3. Call Waiting—Signals the Operator 1 when another call is waiting using the Call Waiting feature of the PBX. 4. Disconnect Message—Disconnects the caller after playing "Thank you for calling".

Table 44

Parameter	Value Range (Default)	Description/Function
No Answer Coverage Mode	<ol style="list-style-type: none"> 1. Caller Select 2. Leave Message 3. Disconnect Message 4. Next Operator (Caller Select) 	<p>Specifies how to handle Operator 1 calls when not answered within the time period set by the "Operator No Answer Time" mode.</p> <ol style="list-style-type: none"> 1. Caller Select—Allows the caller to leave a message or call another extension. (In some cases, a call to another extension is not available. For more information, see the "Note" on "Caller Select" in Table 23 in 5.4.3 Operator's Parameters.) 2. Leave Message—Instructs the caller to leave a message in Operator 1's mailbox. 3. Disconnect Message—Disconnects the caller after playing "Thank you for calling". 4. Next Operator—Transfers the caller to Operator 2.
Message Repeat Cycle	1-3 times (3)	Specifies the number of times the VPS will play the Automated Attendant top menu.

Note

Extension Call Forwarding to the VPS can override the operator call coverage settings depending on the timing parameters of the PBX and VPS. Even if the operator call coverage parameters are set to "Next Operator" on Busy/No Answer, the call may go to the VPS (if the Operator has set the call forwarding to the VPS).

Operator's Parameters-Day Mode-Operator 2

Operator 2 receives operator-seeking calls when Operator 1 is busy or does not answer and Operator 1's parameters are set as follows:

- Busy Coverage Mode—No Answer Coverage
- No Answer Coverage Mode—Next Operator

To access the proper menu for Operator Parameters-Day Mode-Operator 2, follow the menu path as shown:

System Administration Top Menu-1-4-1-2-1-2

Table 45

Parameter	Value Range (Default)	Description/Function
Operator's Extension	1-5 digits (None)	Specifies the extension number for Operator 2. Any valid extension number can be assigned.
Operator's Mailbox No.	2-5 digits (None)	Specifies the mailbox number for Operator 2. Callers to Operator 2 are prompted to leave a message in this mailbox depending upon how the Busy Coverage or No Answer Coverage modes are set.
Busy Coverage Mode	1. Hold 2. No Answer Coverage 3. Call Waiting 4. Disconnect Message (Hold)	Specifies how to handle calls when the Operator 2 extension is busy. 1. Hold—Automatically places the caller on hold and the Operator 2 extension is called again. 2. No Answer Coverage—Offers the option specified by the No Answer Coverage Mode to the caller. 3. Call Waiting—Signals the Operator 2 when another call is waiting using the Call Waiting feature of the PBX. 4. Disconnect Message—Disconnects the call after playing " <i>Thank you for calling</i> ".
No Answer Coverage Mode	1. Caller Select 2. Leave Message 3. Disconnect Message 4. Next Operator (Caller Select)	Specifies how to handle Operator 2 calls when not answered within the time period set by the "Operator No Answer Time" mode. 1. Caller Select—Allows the caller to leave a message or call another extension. (In some cases, a call to another extension is not available. For more information, see the "Note" on "Caller Select" in Table 23 in 5.4.3 Operator's Parameters.) 2. Leave Message—Instructs the caller to leave a message in Operator 2's mailbox. 3. Disconnect Message—Disconnects the caller after playing " <i>Thank you for calling</i> ". 4. Next Operator—Transfers the caller to Operator 3.

Operator's Parameters-Day Mode-Operator 3

Operator 3 receives operator-seeking calls when Operator 2 is busy or unanswered and Operator 2's parameters are set as follows:

- Busy Coverage Mode—No Answer Coverage
- No Answer Coverage Mode—next Operator

To access the proper menu for Operator Parameters-Day Mode-Operator 3, follow the menu path as shown:

System Administration Top Menu-1-4-1-2-1-3

Table 46

Parameter	Value Range (Default)	Description/Function
Operator's Extension	1-5 digits (None)	Specifies the extension number for Operator 3. Any valid extension number can be assigned.
Operator's Mailbox No.	2-5 digits (None)	Specifies the mailbox number for Operator 3. Callers to Operator 3 are prompted to leave a message in this mailbox depending upon how the Busy Coverage or No Answer Coverage modes are set.
Busy Coverage Mode	1. Hold 2. No Answer Coverage 3. Call Waiting 4. Disconnect Message (Hold)	Specifies how to handle calls when the Operator 3 extension is busy. 1. Hold—Automatically places the caller on hold and the Operator 3 extension is called again. 2. No Answer Coverage—Offers the option specified by the No Answer Coverage Mode to the caller. 3. Call Waiting—Signals Operator 3 when another call is waiting using the Call Waiting feature of the PBX. 4. Disconnect Message—Disconnects the call after playing "Thank you for calling".

Table 46

Parameter	Value Range (Default)	Description/Function
No Answer Coverage Mode	1. Caller Select 2. Leave Message 3. Disconnect Message (Caller Select)	Specifies how to handle Operator 3 calls when not answered within the time period set by the "Operator No Answer Time" mode. 1. Caller Select—Allows the caller to leave a message or call another extension. (In some cases, a call to another extension is not available. For more information, see the "Note" on "Caller Select" in Table 23 in 5.4.3 Operator's Parameters.) 2. Leave Message—Instructs the caller to leave a message in Operator 3's mailbox. 3. Disconnect message—Disconnects the caller after playing "Thank you for calling".

Notes

- *An operator-seeking call will always reach Operator 1 first. The call will then be transferred to Operator 2 and Operator 3 sequentially, depending on system programming.*
- *"Next Operator" is not applicable for "No Answer Coverage Mode" of Operator 3.*

Operator's Parameters-Night Mode-Operator 1, 2, 3

Same as Day Mode.

Operator's Parameters-Lunch Mode-Operator 1, 2, 3

Same as Day Mode.

Operator's Parameters-Break Mode-Operator 1, 2, 3

Same as Day Mode.

Alternate Extension Assignment

Assigns extensions that should be transferred differently from the normal extension transfer sequence. Calls to the extensions in this group will be transferred following the sequence defined by "Alternate Extension Transfer Sequence" (see "Alternate Extension Transfer Sequence" in Table 74 in B7.3 PBX Interface Parameters).

To access the proper menu for Alternate Extension Assignment Parameter, follow the menu path as shown:

System Administration Top Menu-1-4-1-3

Alternate Extension Group-Enter

The system can create up to 32 extensions that use the same alternate transfer sequence.

To access the proper menu for Alternate Extension-Enter Parameter, follow the menu path as shown:

System Administration Top Menu-1-4-1-3-1

Table 47

Parameter	Value Range (Default)	Description/Function
Alternate Extension (1-32)	2-5 digits (None)	Specifies an extension, which requires a different transfer sequence than normal. Note: The Extension Group List or Logical Extension Numbers cannot be assigned.

Alternate Extension-Delete

The system can delete extension numbers from the alternate extension group.

To access the proper menu for Alternate Extension-Delete Parameter, follow the menu path as shown:

System Administration Top Menu-1-4-1-3-2

Alternate Extension-Listing

Lists all of the extensions registered in the alternate extension group.

To access the proper menu for Alternate Extension-Listing Parameter, follow the menu path as shown:

System Administration Top Menu-1-4-1-3-3

B5.2 Custom Service

Custom Service is one of 4 incoming call services. By assigning a function to each key, you can provide callers with a customized key operation service. You can establish a maximum of 100 Custom Services with the possible depth of 8 layers. The Message Manager should record Custom Service Menus so that callers will know which key to press.

Note

Callers cannot jump between Custom Service menus more than 8 times.

To access the proper menu for Custom Service Parameter, follow the menu path as shown:

System Administration Top Menu-1-4-2-Custom Service No.(1-100)

Table 48

Parameter	Value Range (Default)	Description/Function
Description	Up to 32 characters (None)	The information typed in this field is for reference only. Any ASCII character (except \) can be used.
Prompt Mode	1. System 2. User 1 3. User 2 (System)	Specifies the language of services within Custom Service. Note: This parameter overrides "Incoming Call Service Prompt".
Menu Repeat Cycle	1-3 times (3)	Specifies the number of times Custom Service menu messages will be repeated to the caller.

Table 48

Parameter	Value Range (Default)	Description/Function
Call Transfer Anytime	Extn./Mbx/No (Extn.)	<p>Specifies the destination to which the call will be transferred. The "Extn." setting (enter "E") enables callers to be transferred directly to their intended party by dialing the extension number. The "Mbx" setting (enter "M") enables callers to leave messages in a mailbox by entering the mailbox number. The "No" setting (enter "N") disables extension transfer and mailbox transfer; only 1-digit entries work (following the Custom Service menu).</p> <p>Note: This parameter should be set to "No" when Subscriber Service is specified as a Custom Service option and it is desired that digits can be entered very quickly to specify a mailbox. Therefore, in most cases, "No" is the best setting for this parameter. This is especially true if you do not want to explain "Call Transfer Any Time" in your Custom Service menu recording.</p>
Wait for Second Digit	1-5 s (1)	<p>Resolves the problem when the first digit of the extension or mailbox number is the same as one of the Custom Service menu choices. The VPS waits the specified period of time for a second digit to be dialed. If the time period expires without a second digit being entered, the system assumes the caller has selected a menu choice. Use this parameter only if "Call Transfer Anytime" is set to "Extn." or "Mbx".</p>
No DTMF Input Operation	a-f (c) *See the following "Keypad Assignment".	<p>Specifies how to handle a call when there is no response to the menu message. No response usually indicates that the caller is using a rotary phone. The factory setting is "C. Operator", which allows the caller to be automatically connected to an operator after message playback.</p>

Table 48

Parameter	Value Range (Default)	Description/Function
Keypad Assignment 0-9, *, #	a-n (*: d, 0: c Others: None)	<p>Any of the 14 services listed below (a-n) can be assigned to the 0 through 9, *, and # keys on the telephone keypad. Callers are able to access these services by pressing the corresponding keys on their telephones.</p> <ul style="list-style-type: none"> (a) Transfer to Mailbox—Allows the caller to leave messages in a specific mailbox. Enter "a" followed by a mailbox number. (b) Transfer to Extension—Transfers the caller to a specific extension. Enter "b" followed by an extension number. (c) Operator—Connects the caller to the operator. (d) Exit—Plays the Custom Service exit prompt and disconnects the caller. The Message Manager is responsible for recording this prompt. (e) Previous Menu—If programmed, returns the caller to the previous menu. (f) Custom Service—If programmed, transfers the caller to another Custom Service. (g) Voice Mail Service—Allows the caller to access Voice Mail Service. (h) Call Transfer Service—Allows the caller to access Automated Attendant Service.

Table 48

Parameter	Value Range (Default)	Description/Function
Keypad Assignment 0-9, *, #	a-n (*: d, 0: c Others: None)	<ul style="list-style-type: none"> (i) Subscriber Service—Allows the caller to access Subscriber Service. If this option is enabled, it is strongly recommended that each subscriber establish a password; this will prevent unauthorized callers from accidentally or intentionally accessing subscribers' mailboxes. (j) Department Dialing—Transfers the caller to the Department Dialing menu. (k) Dial by Name—Requests the caller to enter the first 3 or 4 letters of a last name of the person they wish to reach, then transfers him to the corresponding extension. (l) Repeat Menu—Repeats the Custom Service menu prompts. (m) Main Menu—Returns the caller to the Custom Service top menu. (n) FAX Transfer—Allows the caller to send fax messages to an extension specified as the fax extension.

B5.3 Caller ID Call Routing Parameters

Up to 120 Caller ID numbers can be assigned to be automatically forwarded to a desired destination. The VPS automatically forwards the calls from the assigned Caller ID numbers to a programmed extension, mailbox (System Group Distribution List included) or Custom Service. It also forwards "Private" (caller's number is not received) and "Out of Area" calls to a desired extension, mailbox or Custom Service.

Services have this order of priority:

Holiday Service > Caller ID Call Routing > Trunk Service > Port Service
(Holiday Service has the highest priority.)

To access the proper menu for Caller ID Call Routing, follow the menu path as shown:

System Administration Top Menu-1-4-3

Caller ID Call Routing-Enter

To access the proper menu for Caller ID Call Routing-Enter, follow the menu path as shown:

System Administration Top Menu-1-4-3-1-Caller ID List No.(1-120)

Table 49

Parameter	Value Range (Default)	Description/Function
Caller ID No.	P, O or Up to 20 digits consisting of 1-9, 0, * (None)	Assigns the telephone number to which the VPS applies automatic forwarding to a desired destination. "*" substitutes any number (=wild card). For example, to route all calls from Area Code 201, enter "201 *** **". To have a "Private" call automatically forwarded to a desired destination, enter "P". For an "Out of Area" call, enter "O".
Description	Up to 20 characters (None)	Enters a name and/or description of the Caller ID number. Any ASCII character (except "\") can be used. Note: When nothing is registered in this parameter but the caller's name is transmitted from the Central Office, the name will be automatically registered in this parameter. When this is done, an asterisk "*" will appear with the Call Transfer parameter if "PUTD" is enabled. See 7.2.19 Touchtone Information Display (PUTD) for more information. For example, you might see this: "Custom 3*". This indicates the name was automatically registered in the VPS.
Call Transfer	Custom/Extn./ Mbx (None)	Specifies the destination to which the call from an assigned Caller ID number is automatically forwarded. The "Custom" setting (enter "C") forwards callers to the specified Custom Service menu. The "Extn." setting (enter "E") forwards callers to the specified extension. The "Mbx" setting (enter "M") enables callers to leave messages in the specified mailbox. A System Group Distribution List number can be specified here instead of a mailbox number.

Caller ID Call Routing-Delete

Permits specified Caller ID List numbers to be deleted from the list.

To access the proper menu for Caller ID Call Routing-Delete, follow the menu path as shown:

System Administration Top Menu-1-4-3-2-Caller ID List No.(1-120)

Caller ID Call Routing-Listing

Displays all Caller ID List numbers.

To access the proper menu for Caller ID Call Routing-Listing, follow the menu path as shown:

System Administration Top Menu-1-4-3-3

B6 SYSTEM ADMINISTRATION—SYSTEM PARAMETER SETTINGS

B6.1 System Group Assignment

To access the proper menu for System Group Assignment, follow the menu path as shown:

System Administration Top Menu-1-5-1

System Group Assignment-Mailbox Group

This parameter allows a caller to send a message simultaneously to several mailboxes. These mailboxes may be assembled into a list called a System Group Distribution List. The VPS is able to maintain up to 20 System Group Distribution Lists. Each list can have up to 20 destination mailbox numbers. Mailboxes can be added to or deleted from these lists and reviewed as needed.

To access the proper menu for Mailbox Group, follow the menu path as shown:

System Administration Top Menu-1-5-1-1

Mailbox Group-Enter

To access the proper menu for Mailbox Group-Enter, follow the menu path as shown:

System Administration Top Menu-1-5-1-1-1-Group List No.

Table 50

Parameter	Value Range (Default)	Description/Function
Group List No.	2-5 digits (None)	Specifies any vacant mailbox number. The caller can specify that the VPS transfers or delivers messages to all members of a group by simply specifying the System Group Distribution List No.

Table 50

Parameter	Value Range (Default)	Description/Function
Group Name	Up to 16 characters (None)	Specifies a group name. If a group name is not required, press RETURN, and specify the mailbox numbers. Any alphanumeric character and [(space)] can be used.
Member 1-20	2-5 digits (None)	Specifies mailbox numbers belonging to this group.

Mailbox Group-Delete

Deletes specified mailboxes from the list.

To access the proper menu for Mailbox Group-Delete, follow the menu path as shown:

System Administration Top Menu-1-5-1-1-2-Group List No.

Mailbox Group-Listing

Displays all System Group Distribution List numbers.

To access the proper menu for Mailbox Group-Listing, follow the menu path as shown:

System Administration Top Menu-1-5-1-1-3

System Group Assignment-Extension Group

You can assemble several extensions into a single list. The VPS is able to maintain up to 20 Extension Group Lists. Each list can support up to 20 extensions. You can add, delete, and review the extensions. Members within a list are able to share the same mailbox and be notified by the Message Waiting Notification—Lamp feature (if authorized) when a message is present.

Extension Group-Enter

To access the proper menu for Extension Group-Enter, follow the menu path as shown:

System Administration Top Menu-1-5-1-2-1-Group List No.

Table 51

Parameter	Value Range (Default)	Description/Function
Group List No.	2-5 digits (None)	Specifies any vacant extension number. Note: The Extension Group List number can be assigned as "The Extension of the Owner" of a mailbox. This permits all group members to share the information in the mailbox.
Group Name	Up to 16 characters (None)	Specifies a group name. If a group name is not required, press RETURN, and specify the mailbox numbers. Any alphanumeric character and [(space)] can be used.
Member 1-20	2-5 digits (None)	Specifies the extension number belonging to the group. Note: Members cannot have a personal mailbox.

Extension Group-Delete

Deletes specified extensions from the list.

To access the proper menu for Extension Group-Delete, follow the menu path as shown:

System Administration Top Menu-1-5-1-2-2-Group List No.

Extension Group-Listing

Displays all Extension Group List numbers.

To access the proper menu for Extension Group List Numbers, follow the menu path as shown:

System Administration Top Menu-1-5-1-2-3

B6.2 Time Service

To access the proper menu for Time Service, follow the menu path as shown:

System Administration Top Menu-1-5-2

Time Service-Service Mode

The VPS automatically activates the appropriate call handling method according to the Time Service setting (Day/Night, Lunch, and Break Services); however, the System Administrator or the System Manager can change the current call handling method by selecting a specific Service Mode.

To access the proper menu for Time Service-Service Mode for the selected time group, follow the menu path as shown:

System Administration Top Menu-1-5-2-1

Table 52

Parameter	Value Range (Default)	Description/Function
Service Mode	1. Automatic Mode 2. Manual Day Mode 3. Manual Night Mode 4. Manual Lunch Mode 5. Manual Break Mode 6. PBX Control Mode (Automatic Mode)	Assigns a specific Service Mode. There are 6 options available: 1. Automatic Mode—Operates according to the setting in the Time Service. 2. Manual Day Mode—Operates only in Day Mode. 3. Manual Night Mode—Operates only in Night Mode. 4. Manual Lunch Mode—Operates only in Lunch Mode. 5. Manual Break Mode—Operates only in Break Mode. 6. PBX Control Mode—Operation changes depending on PBX time period. Note: Once the Service Mode has been changed, it is retained unless the System Manager or System Administrator changes it again, even after the power is cut and restored. PBX Control Mode is available only if APT/DPT Integration is activated with a Panasonic KX-TA624 or other KX-T series telephone system. If PBX Control Mode does not function after it has been selected, the VPS will operate in Automatic Mode.

In Automatic Mode, services have this order of priority:

Holiday Service > Caller ID Call Routing > Trunk Service > Port Service
 (Holiday service has the highest priority.)

In Manual Modes (Day, Night, Lunch, or Break), services have this order of priority:

Caller ID Call Routing > Trunk Service > Port Service
 (Holiday Service is disregarded.)

Time Service-Time Service

Time Service is a timer function that selects the desired call handling method based upon time of day: Day, Night, Lunch and Break Services are available.

Night Service can be assigned within Day Service parameters; Night Service starts when Day Service ends, and ends when Day Service starts. There are 3 periods for Break Service: Break 1 Service, Break 2 Service and Break 3 Service.

In each Time Service period, the parameters for Port Service, Trunk Group Service and Operator's Parameters can be specified differently.

Note

Break Service and Lunch Service are only available when they are in Day Service period. If Break 3 Service is out of Day Service period, for example, Break 3 Service does not work.

To access the proper menu for Time Service-Time Service, follow the menu path as shown:

System Administration Top Menu-1-5-2-2

Time Service-Day Service

To access the proper menu for Day Service, follow the menu path as shown:

System Administration Top Menu-1-5-2-2-1

Table 53

Parameter	Value Range (Default)	Description/Function
Mon (Start/End)	1-12: h 00-59: min AM/PM: a.m./p.m.	Specifies the "Start" and "End" times of the Day Service.
Sun (Start/End)	D: Day Mode N: Night Mode (9:00 AM-5:00 PM)	Day Mode: Day Mode in effect around the clock (24 h) Night Mode: Night Mode in effect around the clock (24 h)

Time Service-Lunch Service

To access the proper menu for Lunch Service, follow the menu path as shown:

System Administration Top Menu-1-5-2-2-2

Table 54

Parameter	Value Range (Default)	Description/Function
Mon (Start/End) Sun (Start/End)	1-12: h 00-59: min AM/PM: a.m./p.m. (None)	Specifies the "Start" and "End" times of the Lunch Service.

Time Service-Break Service

To access the proper menu for Break Service, follow the menu path as shown:

System Administration Top Menu-1-5-2-2-3

Table 55

Parameter	Value Range (Default)	Description/Function
Mon Break 1 Service Break 2 Service Break 3 Service (Start/End) Sun Break 1 Service Break 2 Service Break 3 Service (Start/End)	1-12: h 00-59: min AM/PM: a.m./p.m. (None)	Specifies the "Start" and "End" times of the Break Service. Note: When Break Service periods overlap Lunch Service period, Lunch Service has priority.

B6.3 Holiday Setting

You can program special settings for up to 20 Holiday Services. On the day(s) specified as holiday(s), settings in this parameter have priority over settings for Trunk Service, Port Service and Caller ID Call Routing.

When setting specific day(s) as holiday(s), you have the following 2 options:

- The first option is to specify a single day on which to enable the Holiday Service setting. For example, you can specify the New Year's Day as a holiday.
- The second option is to specify a range of days to enable the Holiday Service setting on all days within the specified range. For example, you can specify the start and the end dates of your Christmas vacation.

Note

Holidays cannot overlap. For example, if you have set Dec. 22nd to Jan. 6th as holidays, you cannot set Jan. 1st as a holiday.

To provide a special message to callers on a holiday (for example, "Today is New Year's Day and our office is closed. If you wish to record a message, please press 1 now."), you can create a Custom Service menu. Use this setting to direct calls to this Custom Service on Jan. 1st. Use foreign languages where appropriate.

To access the proper menu for Holiday Setting, follow the menu path as shown:

System Administration Top Menu-1-5-3

Holiday Setting-Enter

To access the proper menu for Holiday Setting-Enter, follow the menu path as shown:

System Administration Top Menu-1-5-3-1-Holiday No.(1-20)

Table 56

Parameter	Value Range (Default)	Description/Function
Name of Holiday	Up to 16 characters (None)	For reference. Any alphanumeric character, and [(space)], [-], [.] and ['] can be used.

Table 56

Parameter	Value Range (Default)	Description/Function
Date	MM/DD-MM/DD or MM/DD (MM: Month DD: Day) (None)	Specifies the day or the range of days on which to enable Holiday Service setting. <ul style="list-style-type: none"> • If you want to set a single day as a holiday, specify only one date. • If you want to set a range of days as holidays, specify both the start and the end dates of the range. <p>Note: Holidays cannot overlap.</p>
Retain Holiday	1. Yes 2. No (No)	Stores the Holiday Service setting for future use. If set to "Yes", the same setting will be activated automatically on the same day every year. If set to "No", the setting will be canceled automatically after the holiday is over.
Service	1. Voice Mail 2. Auto. Attn. 3. Interview 4. Custom (Auto. Attn.)	Specifies one of 4 incoming call services for the holiday. <p>Note: When Interview Service is specified, one of Subscriber's Interview Mailbox numbers should also be specified. When the Custom Service is specified, one of Custom Service numbers (1-100) should also be specified.</p>
Port Affected	Port No. (1-2)	Specifies the port number on which the Holiday Service setting is activated. The unspecified ports provide the usual incoming call service. <p>Note: Pressing [(back space)] will clear the parameter.</p>
Trunk Affected	Trunk No. (1-24)	Specifies the trunk (CO line) number on which the Holiday Service setting is activated. The unspecified trunks (CO lines) provide the usual incoming call service. <p>Note: Pressing [(back space)] will clear the parameter.</p>

Holiday Setting-Delete

Cancels the Holiday Service Setting by specifying a holiday number (1-20).

To access the proper menu for Holiday Setting-Delete, follow the menu path as shown:

System Administration Top Menu-1-5-3-2

Holiday Setting-Listing

Displays all of the specified holiday names and dates.

To access the proper menu for Holiday Setting-Listing, follow the menu path as shown:

System Administration Top Menu-1-5-3-3

B6.4 Daylight Saving Time (DST)

Adjusts the internal clock of the VPS to the starting and ending date of daylight saving time.

To access the proper menu for Daylight Saving Time, follow the menu path as shown:

System Administration Top Menu-1-5-4

Table 57

Parameter	Value Range (Default)	Description/Function
Start Date/End Date	MM: Month DD: Day (None)	Specifies the starting and ending dates of daylight saving time. The VPS advances 1 h on the starting date of daylight saving time, and restores the time on the ending date. Both the starting date and the ending date must be set. The same date cannot be used for both settings. Warning: Time Synchronization (see 7.2.4 Set Time (TIME)) overrides the DST setting of the VPS.

Note

The VPS changes to and from DST at 2:00 AM. According to current U.S. guidelines, in most of the United States, DST begins at 2:00 AM on the first Sunday in April and ends at 2:00 AM on the last Sunday in October.

B6.5 Prompt Setting

This setting is required when Multilingual Service is enabled.

To access the proper menu for Prompt Setting, follow the menu path as shown:

System Administration Top Menu-1-5-5

Table 58

Parameter	Value Range (Default)	Description/Function
System Prompt Selection Number	1-9 (None)	<p>Assigns a selection number (1-9) to each prompt. Callers use the numbers to select the desired language for their message prompts. This setting is required when either one or both of the following parameters are set to "Selective".</p> <p>Port Assignment—Incoming Call Service Prompt Authorization of External Message Delivery—Prompt Mode</p> <p>Example: <i>For service in English, press (7).</i> <i>For service in French, press (8).</i> <i>For service in Chinese, press (9).</i></p> <p>The Message Manager is responsible for recording this Multilingual Selection Menu.</p> <p>Note: The Prompt Selection Number should not match the first digit of any mailbox number, because mailbox/extension access is possible during and after the Multilingual Selection Menu.</p>
User 1 Prompt Selection Number		
User 2 Prompt Selection Number		
Position of "AM/PM" in Time Stamp for User 1 Prompt	1. Before 2. After 3. 24-h (After)	<p>This parameter setting is functional only when User 1 or User 2 Prompts are in use. This parameter specifies the following:</p> <ol style="list-style-type: none"> 1. Before—the VPS announces "AM/PM" before the time (e.g., <i>P.M. 3:42</i>). 2. After—The VPS announces "AM/PM" after the time (e.g., <i>3:42 P.M.</i>). 3. 24-h—the VPS announces the time in 24-h format (e.g., <i>15:42</i>). <p>Note: When System Prompts are in use, the parameter is set to "After".</p>
Position of "AM/PM" in Time Stamp for User 2 Prompt		

B6.6 System Caller Name Announcement

Up to 120 Caller ID numbers can be assigned to announce prerecorded Caller ID caller names when extension users listen to messages from the assigned numbers left in their mailbox. Extension users can also hear caller names when the VPS forwards calls from the assigned numbers to them (Caller ID Screening). The recorded caller names will also play when the callers use the Intercom Paging features; the recorded names will be added to the end of the page.

The Caller ID Screening feature is enabled or disabled in the COS (Class of Service) settings. This feature is also enabled by selecting "Call Screening" in 4.1 Call Transfer Status in the Subscriber's Guide.

The Intercom Paging feature is enabled by selecting "Intercom Paging" in 4.1 Call Transfer Status, and/or in 4.3 Incomplete Call Handling Status in the Subscriber's Guide.

The Message Manager is responsible for recording System Caller Names.

To access the proper menu for System Caller Name Announcement, follow the menu path as shown:

System Administration Top Menu-1-5-6

System Caller Name Announcement-Enter

To access the proper menu for System Caller Name Announcement-Enter, follow the menu path as shown:

System Administration Top Menu-1-5-6-1-Caller ID List No.(1-120)

Table 59

Parameter	Value Range (Default)	Description/Function
Caller ID No.	Up to 20 digits consisting of 1-9, 0 (None)	Assigns the telephone number for which the VPS announces prerecorded caller name to extension users.
Description	Up to 20 characters (None)	Enters a name and/or description of the Caller ID number. Any ASCII character (except \) can be used.

System Caller Name Announcement-Delete

Deletes specified Caller ID List numbers from the list.

To access the proper menu for System Caller Name Announcement-Delete, follow the menu path as shown:

System Administration Top Menu-1-5-6-2-Caller ID List No.(1-120)

System Caller Name Announcement-Listing

Displays all Caller ID List numbers.

To access the proper menu for System Caller Name Announcement-Listing, follow the menu path as shown:

System Administration Top Menu-1-5-6-3

B6.7 Other Parameters

To access the proper menu for Other Parameters, follow the menu path as shown:

System Administration Top Menu-1-5-7

Other Parameters-Extension Numbering Plan

Specifies the extension numbers of the PBX so that the VPS is able to recognize the dialed extension as valid. This setting promotes the call handling of the Automated Attendant Service. We recommend that this parameter be set for better integration with the PBX.

To access the proper menu for Extension Numbering Plan, follow the menu path as shown:

System Administration Top Menu-1-5-7-1

Table 60

Parameter	Value Range (Default)	Description/Function
Numbering Plan 1-16	2-5 digits consisting of 0-9, X (Numbering Plan 1: 1XX; Numbering Plan 2-16: None)	<p>Specifies the first 1 or 2 digits of the PBX extension numbers. You can add up to 16 entries to the list. Each entry can contain 2-5 digits "0-9", and a letter "X" which matches any digit. Extension numbers cannot begin with "0".</p> <p>Examples:</p> <p>a) If valid PBX extension numbers are to be specified 101 through 164 and 201 through 264, specify the numbers as follows:</p> <p style="padding-left: 40px;">1XX: Indicates any 3-digit extension number starting with "1".</p> <p style="padding-left: 40px;">2XX: Indicates any 3-digit extension number starting with "2".</p> <p>b) If valid PBX extension numbers are to be specified 400 through 450 and 3300 through 3399, specify the numbers as follows:</p> <p style="padding-left: 40px;">4XX: Indicates any 3-digit extension number starting with "4".</p> <p style="padding-left: 40px;">33XX: Indicates any 4-digit extension starting with "33".</p> <p>Note: Auto Configuration will set this parameter automatically.</p> <p>The Automated Attendant will dial any 2-5 digit PBX extension number (except numbers beginning with "0") whether valid or not. If the dialed number is included in the numbering plan, the Automated Attendant will immediately send it to the PBX without waiting for further input. If not, the Automated Attendant will wait until the dialed number is recognized as an extension number, the internal inter-digit timer expires, or the caller dials 5 digits.</p> <p>If the number for an outgoing call is not found on the Numbering Plan, the VPS will consider it an outside number. The VPS will then attempt to dial it using the "Outgoing Call Setup Sequence".</p>

Other Parameters-Dialing Parameter

To access the proper menu for Dialing Parameter, follow the menu path as shown:

System Administration Top Menu-1-5-7-2

Table 61

Parameter	Value Range (Default)	Description/Function
Number of Digits to Access Outside Line	0-8 digits (1)	Specifies the number of digits necessary to access an outside (CO) line. Example: If the PBX requires callers to dial "9" to access an outside (CO) line, this parameter should be set as "1". This enables the system to recognize that an outgoing call setup sequence is completed once the initial "9" has been dialed (9-123-4567). The full sequence is therefore: 9-(outgoing call setup sequence)-123-4567. The VPS can discriminate between local and long distance calls and can report outgoing calls and calling times for billing purposes on periodic port usage reports.
Call Transfer No Answer Time	10-60 s (20)	Specifies the length of time that the VPS must wait before retrieving the transferred call when there is no answer at the destination extension. Note: Make sure that the duration of Call Transfer No Answer Time is longer than the duration of Call Forwarding No Answer Time at the PBX. Otherwise, the PBX may forward the call (transferred by the VPS) immediately to its destination without leaving enough time to answer the call.
Outgoing Call No Answer Time	10-90 s (30)	Specifies the length of time that the VPS must wait before concluding that there is no answer at the outside number called.
Pause Time	1-9 s (2)	Specifies the pause time between dialed digits.

Table 61

Parameter	Value Range (Default)	Description/Function
Outgoing Call Setup Sequence	Up to 12 digits consisting of 0-9, *, #, F, R, S, T, W (T)	Specifies the sequence of codes used by the VPS when calling a CO line. You can set up to 12 digits. The default value is "T". "T" indicates that the system will dial the telephone number only after detecting a dial tone. Example: 9W = (9) - 1-s wait - dial telephone number. "9" is the CO line access number. F: Hook Flash R: Ringback Tone Detection S: Silence Detection T: Dial Tone Detection W: Wait for 1 s 1-9, 0, *, #: Dial Codes

Other Parameters-Message Waiting Notification

Controls the handling of message waiting notification calls.

To access the proper menu for Message Waiting Notification Parameter, follow the menu path as shown:

System Administration Top Menu-1-5-7-3

Table 62

Parameter	Value Range (Default)	Description/Function
Outgoing Call Ports	Port No. (1-2)	Specifies the port numbers used for the Message Waiting Notification Device feature. The VPS makes outgoing calls using the port specified in this parameter. At least 1 port must be specified.

Table 62

Parameter	Value Range (Default)	Description/Function
Message Waiting Lamp Ports	Port No. (1-2)	Specifies the port numbers used for the Message Waiting Notification Lamp feature. The VPS turns on the Message Waiting Lamp of the extension using the port specified in this parameter. At least 1 port must be specified.
Message Waiting Lamp for Every Message	1. No 2. Yes (Yes)	If set to "Yes", the VPS will turn on the Message Waiting Lamp of the extension each time a new message is recorded in the mailbox. This will occur even if the Message Waiting Lamp was not turned off from a previous message. This setting is useful when the first attempt is unsuccessful. If set to "No", the VPS will turn on the Message Waiting Lamp for the first message only. The VPS will not turn on the lamp for subsequent messages until the subscriber has accessed the VPS to retrieve the messages stored there.
Max. Digits for Callback No.	1-48 digits (20)	Specifies the maximum number of digits the caller can enter as a callback number. This number will display on beepers if the "Beeper Callback No. Entry Mode" is enabled.
Callback No. Entry Interdigit Time-Out	1-10 s (5)	Sets the maximum allowable time between each digit on Beeper Callback No. Entry. If the caller does not enter any digits within the specified time, the VPS will not accept entry of any additional digits.
System Callback No.	Up to 32 digits (None)	Specifies a telephone number that will display on the subscriber's beeper as a callback number. The callback number entry mode "X" must be included in the telephone number. Note: If "Beeper Callback No. Entry Mode" is enabled through COS, the callback number entered by the caller will display on the destination beeper. However, if the caller fails to enter a callback number, the System Callback No. will display instead.

Other Parameters-External Message Delivery

Controls the handling of External Message Delivery calls.

To access the proper menu for External Message Delivery, follow the menu path as shown:

System Administration Top Menu-1-5-7-4

Table 63

Parameter	Value Range (Default)	Description/Function
Retry Times	0-9 times (3)	Specifies the number of times to attempt an external message delivery call when the destination is busy or if there is no answer.
Busy Delay	1-60 min (3)	Specifies the length of time in minutes the VPS must wait after a busy condition is received before trying to deliver the message again.
No Answer Delay	60-120 min (60)	Specifies the length of time in minutes the VPS is to wait after a no answer condition is received before trying to deliver the message again.
Outgoing Call Ports	Port No. (1-2)	Specifies the port numbers used for the External Message Delivery feature.
Message Length	1-6 min (3)	Specifies the allowable message length of external delivery messages that the subscriber can record.
Max. Messages for Mailboxes	1-100 msgs (3)	Specifies the maximum number of external delivery messages that can be stored in 1 mailbox.
System External Message Delivery Duration Time	1-9 min (3)	Specifies the maximum telephone connect time allowed for an external message delivery call to prevent excessive telephone charges. Time begins counting when the destination number answers the call. The VPS terminates the call when it exceeds the specified length of time. However, the VPS does not terminate a call until the whole message is played even though the specified time expires.
Callback Telephone No.	Up to 32 digits (None)	Specifies the Callback Telephone Number. When the recipient has failed to retrieve the sender's message because of incorrect password entries, the VPS announces the Callback Telephone Number for him to call in order to retrieve it.

Other Parameters-Call Hold

To access the proper menu for Call Hold, follow the menu path as shown:

System Administration Top Menu-1-5-7-5

Table 64

Parameter	Value Range (Default)	Description/Function
Call Hold Mode	1. Disable 2. Enable (Enable)	If set to "Enable", the VPS gives callers the option of either holding for a specific extension or selecting one of several Incomplete Call Handling service options. While on hold, the VPS periodically gives callers the choice to either continue to hold or select one of the Incomplete Call Handling service options. If set to "Disable", the VPS immediately offers callers the Incomplete Call Handling service.
Call Queuing Announcement Mode	1. Disable 2. Enable (Enable)	If set to "Enable", callers on hold are informed of their current position in the call hold queue. Example: <i>"One other person is waiting to connect".</i>
Call Retrieval Announcement Timing	1-30 s (2)	Specifies the interval between the voice guidance message that asks whether or not calls are to be retrieved during call holding. Example: <i>"To cancel holding, press 2 now. Otherwise, I'll try your party again".</i>
Redialing Cancel Timing	1. 15 s 2. 30 s 3. 45 s 4. 60 s (30)	Specifies the interval between the voice guidance messages that ask if continuous redials are to be attempted during call holding. Example: <i>"To continue holding, press 1. Otherwise, press 2".</i>

Other Parameters-Rotary Telephone Service

Specifies how to treat callers who are calling from rotary telephones (unable to input touchtone signals) or who are unable to properly respond to VPS guidance.

To access the proper menu for Rotary Telephone Service, follow the menu path as shown:

System Administration Top Menu-1-5-7-6

Table 65

Parameter	Value Range (Default)	Description/Function
Rotary Telephone Call Coverage (Day), (Night)	1. G. D. M. 2. Operator Extension (G. D. M.)	Defines how the VPS treats calls received from rotary telephones or calls from callers that are unfamiliar with the VPS operation in the Voice Mail Service. Note: G.D.M. = General Delivery Mailbox.

Other Parameters-Intercom Paging Parameter

Intercom Paging is a PBX feature that makes it possible to page the caller's party through telephone speakers. To utilize this feature, the PBX must have the Intercom Paging feature available and the VPS must be properly programmed. This feature is available for APT/DPT Integration mode only.

To access the proper menu for Intercom Paging Parameter, follow the menu path as shown:

System Administration Top Menu-1-5-7-7

Table 66

Parameter	Value Range (Default)	Description/Function
Intercom Paging Sequence	Up to 12 digits consisting of 0-9, *, # and special codes (FXW)	Specifies the intercom paging sequence required by the PBX. This can be programmed using up to 12 of the following 8 letters and 12 dial codes. D: Disconnecting F: Hook Flash R: Ringback Tone Detection S: Silence Detection T: Dial Tone Detection W: Wait for 1 s X: Pager Dialing A: Answer 1-9, 0, *, #: Dial Codes
Release for Intercom Paging	Up to 12 digits consisting of 0-9, *, # and special codes (FW)	Specifies the intercom paging release code required by the PBX. This can be programmed using up to 12 of the 8 letters and 12 dial codes as specified above.
No Answer Time for Intercom Paging	1-30 s (5)	Specifies the length of time (in seconds) the VPS must wait before concluding Intercom Paging when there is no answer. The VPS will return to the caller if the paged party does not respond before this timer expires.
Announcement Repeat Cycle	1-3 times (1)	Specifies the number of times to announce the intercom page. Example: <i>"I have a call for (mailbox owner's name)".</i>
Intercom Paging Retry	1-10 times (2)	Specifies the number of times to retry paging when the paging destination is busy or if there is no answer. Note: This setting applies only when the subscriber has enabled "Intercom Paging" in Incomplete Call Handling Status.

Table 66

Parameter	Value Range (Default)	Description/Function
Paging Code for Group 1-8	Up to 12 digits consisting of 0-9,*,# for each group (Group 1-8: 331-338; All Groups [Group 9]: 33*)	Specifies the intercom paging access code required by the PBX. Note: The Intercom Paging Group Number available for each subscriber is determined on a COS-by-COS basis.
Paging Code for All Groups		

Other Parameters-Fax Management

You can program the VPS to automatically forward incoming fax calls to a fax extension. You can specify a maximum of 2 fax extensions as the destination for the Automatic Fax Transfer. If the main fax extension is not available to receive a fax, the VPS will forward the fax transmission to the alternate fax extension.

To access the proper menu for Fax Management, follow the menu path as shown:

System Administration Top Menu-1-5-7-8

Table 67

Parameter	Value Range (Default)	Description/Function
Automatic Transfer of Incoming Fax Call	1: Disable 2: Enable (Disable)	Enables or disables the Automatic Transfer of Incoming Fax Call Service. Note: Automatic detection works for only the first 30s.
Main Fax Extension No.	2-5 digits (None)	Specifies the main fax extension number.
Alternate Fax Extension No.	2-5 digits (None)	Specifies the alternate fax extension number. When the main fax extension is busy or does not answer within the specified "Fax No Answer Time", the VPS forwards the fax call to the alternate fax extension.

Table 67

Parameter	Value Range (Default)	Description/Function
Fax No Answer Time	5-60 s (10)	Specifies the length of time (in seconds) the VPS must wait before taking other action when there is no answer at either fax extension. Note: This timer applies to the fax call that has been transferred to the main or alternate fax extension.
Fax Manager Mailbox No.	2-5 digits (None)	Specifies the Fax Manager Mailbox Number. The VPS will notify the fax manager of the status of fax calls depending upon the settings of the "Fax No Answer Coverage Mode" and "Fax Notification Mode " parameters.
Fax No Answer Coverage Mode	1. No 2. Mbx 3. Ext (No)	If set to "Mbx", the VPS will leave the number of unanswered fax calls in the Fax Manager's mailbox. Example: <i>"The FAX transfer situation is as follows. One attempt was no answer"</i> . 1. If set to "Ext", the VPS will call the Fax Manager's extension to specify the number of unanswered fax calls received. 2. If set to "Mbx", the VPS will leave the number of unanswered fax calls in the Fax Manager's mailbox. 3. If set to "No", the VPS will take no action concerning unanswered fax calls.
Fax Notification Mode	1. No 2. Mbx 3. Ext (No)	If set to "Mbx", the VPS will leave the number of successfully received fax calls in the Fax Manager's mailbox. Example: <i>"You have 1 FAX message"</i> . 1. If set to "Ext", after a fax extension successfully receives a fax call, the VPS will automatically call the Fax Manager's extension and play a voice prompt: <i>"You have 1 FAX message"</i> . The VPS will also leave the total number of received fax calls in the Fax Manager's mailbox. 2. If set to "No", the VPS will not take any action concerning successfully received fax calls.

Other Parameters-Disconnect Parameter

To access the proper menu for Disconnect Parameter, follow the menu path as shown:

System Administration Top Menu-1-5-7-9

Table 68

Parameter	Value Range (Default)	Description/Function
Maximum Silence Time	5-60 s (10)	Specifies the length of time (in seconds) that the VPS must wait until it disconnects the call when silence is detected.

B7 SYSTEM ADMINISTRATION—HARDWARE SETTINGS

For System Administration (system setup, mailbox setup, and system diagnosis), an RS-232C terminal must be connected to the serial interface of the VPS.

To access the proper menu for Hardware Setting, follow the menu path as shown:

System Administration Top Menu-1-6

B7.1 RS-232C Parameters

To access the proper menu for RS-232C Parameter, follow the menu path as shown:

System Administration Top Menu-1-6-1

Table 69

Parameter	Value Range (Default)	Description/Function
Baud Rate	1. 300 bps 2. 600 bps 3. 1200 bps 4. 2400 bps 5. 4800 bps 6. 9600 bps 7. 19200 bps 8. 38400 bps (9600)	Specifies the speed at which the data is transferred in bits per second.
Word Bit Length	1. 7 bits 2. 8 bits (8 bits)	Defines the number of bits in each byte or character.
Parity	1. None 2. Odd 3. Even (None)	Specifies the parity to use for error detection.
Stop Bit Length	1. 1 bit 2. 2 bits (1 bit)	Specifies the number of bits used to signify the end of the byte.

B7.2 Port Setting

To access the proper menu for Port Setting, follow the menu path as shown:

System Administration Top Menu-1-6-2

Port Setting Menu

To access the proper menu Port Setting Menu for the selected port, follow the menu path as shown:

System Administration Top Menu-1-6-2-Port No.(1-2)

Table 70

Parameter	Value Range (Default)	Description/Function
Flash Time	1. 100 ms 2. 300 ms 3. 600 ms 4. 900 ms (600)	Specifies the length of time the hook switch must be pressed before the PBX will recognize it as a flash hook signal. See the PBX manual to determine the correct value.
CPC Signal	1. None 2. 6.5 ms 3. 150 ms 4. 300 ms 5. 450 ms 6. 600 ms (None)	Specifies the minimum time necessary to detect an interruption in the CPC (Calling Party Control) signal received from the PBX. The VPS is able to determine that the line has been disconnected when it detects an interruption of the CPC signal.
Disconnect Time	1-8 s (2)	Specifies the length of time the line will temporarily be unavailable after a call has ended.
Dial Mode	1. DTMF 2. Pulse 10 pps 3. Pulse 20 pps (DTMF)	Specifies the dial mode for DTMF (touchtone) or Pulse. If Pulse is specified, pulse speed (10/20 pps) must be selected. Note: This setting only affects outward dialing from the VPS. The VPS can only receive DTMF (touchtone) signals.

B7.3 PBX Interface Parameters

Three separate parameters are used to program the VPS for optimal signaling and performance with the PBX.

To access the proper menu for PBX Interface Parameters, follow the menu path as shown:

System Administration Top Menu-1-6-3

Dialing Parameters

These parameters specify how the VPS will initiate and control call transfers, setup outgoing calls, and control message waiting lamps on extensions. The procedure for verifying the correct code sequences for non-Panasonic KX-T series telephone systems is to manually execute the sequences from a single line telephone (SLT) with the PBX.

To access the proper menu for Dialing Parameters, follow the menu path as shown:

System Administration Top Menu-1-6-3-1

Table 71

Parameter	Value Range (Default)	Description/Function
PBX Type	1. Other Manufacturers 2. KX-T Series 1. T308/T616 2. T1232 3. T96 4. T336 5. TD816/TD1232/TA1232 6. TD308 7. TA series (TA series)	Specifies the type of PBX connected to the VPS. In the case of a Panasonic KX-T series telephone system, the model number should also be specified. Notes: The Dialing Parameters are set automatically to each PBX default value after selecting the PBX type.

Table 72

PBX Type	Other Manufacturers	KX-T series							
		T308/ T616	T1232	T96	T336	TD816/ TD1232/ TA1232/ TD308	TA series		
Integration Mode	None	None	None	None	None	None	* ₁ DPT	None	* ₂ APT
	Inband		Inband	Inband	Inband	Inband		Inband	
Operator Transfer Sequence	FX	FTX	FTX	FTX	FTX	FTX	FX	FTX	FX
Extension Transfer Sequence	FX	FTX	FTX	FTX	FTX	FTX	FX	FTX	FX
Alternate Extension Transfer Sequence	FX	FTX	FTX	FTX	FTX	FTX	FX	FTX	FX
Reconnect Sequence on Busy	FWW	FWW	FWW	FWW	FWW	FWW	F	FWW	F
Reconnect Sequence on No Answer	FWW	FWW	FWW	FWW	FWW	FWW	F	FWW	F
Reconnect Sequence on Refuse Call	FWW	FWW	FWW	FWW	FWW	FWW	F	FWW	F
Light-On Sequence for Message Waiting Lamp	None	N/A	T701X #	T#91X	T×9X	T701X	—	T701X #	—
Light-Off Sequence for Message Waiting Lamp	None	N/A	T702X #	T#90X	T#9X	T700X	—	T702X #	—

Table 72

PBX Type	Other Manufacturers	KX-T series							
		T308/ T616	T1232	T96	T336	TD816/ TD1232/ TA1232/ TD308	TA series		
Call Waiting Sequence	None	N/A	1	N/A	N/A	1	1	1	1
Release Sequence for Call Waiting	None	N/A	F	N/A	N/A	F	F	F	F

*1 When your KX-T series telephone system is in DPT Integration mode.

*2 When your KX-TA624 telephone system is in APT Integration mode.

N/A Not available

— Not needed

Table 73

Parameter	Value Range (Default)	Description/Function
Integration Mode	1. None 2. Inband 3. APT 4. DPT (APT)	Specifies the method of integrating the VPS with the PBX. 1. None—Both PBX and VPS work independently, without accessing information concerning the status of the other. 2. Inband—The PBX sends touchtone codes to the VPS to indicate the state of the call (busy, answered, disconnect, etc.). Inband Integration improves the VPS performance because call state recognition is faster than with standard call progress tone detection. The PBX code for each call state must be set in the Inband Signaling Parameters. If PBX type is set to a KX-T series telephone system, the Inband Signaling Parameters will automatically default to the proper codes. This is available with any of the following Panasonic KX-T series telephone systems: T1232, TA series, T96, T336, TD816, TD1232, TA1232, and TD308. 3. APT—The VPS communicates with the PBX via the APT interface. This is available only with Panasonic KX-TA624. 4. DPT—The VPS communicates with the PBX via the DPT interface. This is available with any of the following Panasonic KX-T series telephone systems: TD816, TD1232, TA1232, and TD308.
Extension Number of VPS Port 1-2	2-4 digits (Port 1-2: 107-108)	Specifies the extension number of each VPS port. Note: Extension numbers of the VPS ports will automatically be assigned when: (1) Auto Configuration is executed, or (2) PBX type has been changed.

To program the following 10 Parameters in the next table, use the Special Commands and Dial Codes listed below. You can set up to 12 digits for each parameter.

D: Disconnecting
 F: Hook Flash
 R: Ringback Tone Detection
 S: Silence Detection
 T: Dial Tone Detection
 W: Wait for 1 s
 X: Extension dialing
 A: Answer
 1-9, 0, *, #: Dial Codes

Table 74

Parameter	Value Range (Default)	Description/Function
Operator Transfer Sequence	(FX)	The VPS performs this sequence when transferring calls to the operator's extension.
Extension Transfer Sequence	(FX)	The VPS performs this sequence when transferring calls to any extension except the operator's.
Alternate Extension Transfer Sequence	(FX)	The VPS performs this sequence when transferring calls to extensions in the Alternate Extension Group.
Reconnect Sequence on Busy	(F)	If an extension is busy, this sequence allows the VPS to reconnect to the caller.
Reconnect Sequence on No Answer	(F)	If the extension does not answer, this sequence allows the VPS to reconnect with the caller.
Reconnect Sequence on Refuse Call	(F)	The VPS performs this sequence to retrieve a call placed on hold after the extension (in the Call Screening mode) has refused to accept it.
Light-On Sequence for Message Waiting Lamp	(None)	This is the dialing sequence that the VPS must perform to enable the Message Waiting Lamp at an extension.
Light-Off Sequence for Message Waiting Lamp	(None)	This is the dialing sequence that the VPS must perform to disable the Message Waiting Lamp at an extension.

Table 74

Parameter	Value Range (Default)	Description/Function
Call Waiting Sequence	(1)	The VPS carries out this sequence when performing call waiting if the extension being called is busy.
Release Sequence for Call Waiting	(F)	The VPS performs this sequence to release call waiting.

Inband Signaling Parameters

Use these parameters if the PBX sends touchtones to the VPS to indicate the state of a call (busy, answered, disconnected, etc.). The integration mode must be set to "Inband". If PBX type is set to a KX-T series telephone system, the Inband Signaling parameters will automatically default to the proper codes.

To access the proper menu for Inband Signaling Parameters, follow the menu path as shown:

System Administration Top Menu-1-6-3-2

The following parameters can be programmed using "0-9", "×", "#", and "A-D".

Table 75

Parameter	Value Range (Default)	Description/Function
Ringback	(1)	Indicates "Ringback Tone". Sent to the VPS when the extension dialed is ringing.
Busy	(2)	Indicates "Busy Tone". Sent to the VPS when the extension dialed is busy.
Reorder	(3)	Indicates "Reorder Tone". Sent to the VPS when an invalid extension number is dialed or when inadvertently connected to another VPS.
DND	(4)	Indicates "Do Not Disturb Tone". Sent to the VPS if the dialed extension has the Do Not Disturb feature enabled.
Answer	(5)	Sent to the VPS when the called extension answers the call.
Forward to VM Ringing	(6)	Sent to the VPS if the called extension is forwarded to a voice mail port and that voice mail port is available to accept the call.

Table 75

Parameter	Value Range (Default)	Description/Function
Forward to VM Busy	(7)	Sent to the VPS if the called extension is forwarded to a voice mail port and that voice mail port is not available to accept the call.
Forward to Other Extension	(8)	Sent to the VPS if the called extension is forwarded to another, non-Voice Mail extension.
Confirmation	(9)	Sent to the VPS when it successfully dialed a Message Waiting Lamp On or Message Waiting Lamp Off Code.
Disconnect	(#9)	Sent to the VPS when the other party goes "on-hook".

Note

Default values in the above table vary depending on the settings of "PBX type" and "Inband Integration" (PBX Interface Parameters).

Table 76

Parameter	Other Manufacturers	KX-T series						
		T308/T616	T1232	T96	T336	TD816/ TD1232/ TA1232	TD308	TA series
Ringback	N/A	N/A	1	A1	A1	1	1	1
Busy	N/A	N/A	2	B1	B1	2	2	2
Reorder	N/A	N/A	3	B2	B2	3	3	3
DND	N/A	N/A	4	B3	B3	4	4	4
Answer	N/A	N/A	5	A2	A2	5	5	5
Forward to VM Ringing	N/A	N/A	6	C1	C1	6	6	6
Forward to VM Busy	N/A	N/A	7	C2	C2	7	7	7
Forward to Other Extension	N/A	N/A	8	C3	C3	8	8	8
Confirmation	N/A	N/A	9	D1	D1	9	9	9
Disconnect	N/A	N/A	#9	DD	DD	#9	#9	#9

N/A: Not available

Digit Translation Table Parameters

Use the Digit Translation Table to translate the Follow On ID Signal from the PBX into the proper codes for the VPS. This translation table is only effective for the incoming signal.

To access the proper menu for Digit Translation Table Parameters, follow the menu path as shown:

System Administration Top Menu-1-6-3-3

Digit Translation Table Parameters-Inter-Digit Timeout

To access the proper menu for Inter-Digit Timeout, follow the menu path as shown:

System Administration Top Menu-1-6-3-3-1

Table 77

Parameter	Value Range (Default)	Description/Function
Inter-Digit Timeout	1-4 s (1)	Defines the incoming signal interval (Follow on ID). The Digit Translation Table is translated by a series of signals received within the specified time period.

Digit Translation Table Parameters-Input/Output

To access the proper menu for Input/Output, follow the menu path as shown:

System Administration Top Menu-1-6-3-3-2

Table 78

Parameter	Value Range (Default)	Description/Function
Table 1-8	Up to 8 digits consisting of 0-9, *, #, A-D (None)	Do not assign more than 1 code to an incoming signal. If this occurs, the system will take the first assignment.
	Input digit	
	Output digit	

Appendix C
SYSTEM MANAGER'S GUIDE

C1 ACCESSING THE SYSTEM MANAGER'S MAILBOX

The System Manager's Mailbox must be accessed before performing any System Manager task. To access the System Manager's Mailbox, three items of information must be known: the telephone number connected directly to the Voice Mail Service, the System Manager's Mailbox Number and the Password for that mailbox (if assigned). The System Manager's Mailbox Number is 99, 999 (default), 9999 or 99999 depending upon the mailbox number length specified in System Programming. The System Manager's password is assigned through the System Manager's Service.

To Access the System Manager's Mailbox

1. **Dial the Extension Number** connected to the Voice Mail Service. Or **Dial any VPS Extension Number** and **Press [#] [6]** (Service Access Command).

*Please enter your party's mailbox number.
To enter by name, press [#] and [1].
If you are using a rotary telephone, stay on the line.
To call the operator, press [0].*

2. **Press [*]**, then **Type the System Manager's Mailbox Number** (99, 999, 9999 or 99999).

Enter your password, followed by [#].

3. **Type the Password** followed by [#]. The Main Menu of System Manager's Service will be played:

*You have (number) new message(s).
To receive the message, press [1].
To deliver a message, press [2].
To customize your mailbox, press [3].
To check the mailbox distribution, press [4].
For a system report, press [5].
For other features, press [6].
To end this call, press [*].*

C2 SETTING UP MAILBOXES

The System Manager's primary function is to create mailboxes for new subscribers and to maintain system organization by deleting unneeded passwords and mailboxes.

Note

While the System Administrator programs via a personal computer, the System Manager cannot set up mailboxes. The VPS plays "Sorry, this function is not available".

Creating and Editing a Mailbox

The System Manager can both create and edit Subscriber Mailboxes by following the steps below.

At any step, when editing an assigned mailbox's parameters, change current settings by **Pressing [1]**. To leave the current setting unchanged, **Press [2]**.

When creating a new mailbox, the following parameters can be set:

- *Mailbox Number*
- *Subscriber's Voiced Name—The VPS allows a maximum of 4 s to record the name. The name must be spoken slowly and clearly. Use the subscriber's last name.*
- *Extension Number*
- *Initial 3 or 4 Letters of the Subscriber's Last Name—Enter only the first 3 or 4 letters of the owner's last name.*
- *Class of Service Number—Enter any COS number (1-62).*
- *Interview Mailbox Number—Interview Mailbox Numbers must be different from Subscriber Mailbox Numbers*
- *All Calls Transfer Mailbox*

Follow the steps listed below to create, edit or delete any mailbox parameter.

- 1. Log in** to the Main Menu.
- 2. Press [6]** for Other Features.
- 3. Press [1]** for Mailbox Setup.
- 4. Press [1]** to Assign or Edit.
- 5. Type the mailbox number.**

6. **Press [2]** to accept the entry.
7. As each parameter plays:
 - a) **Press [1]** to enter the new parameter or **[2]** to leave the parameter unchanged.
 - b) Enter the parameter.
 - c) Confirm the new parameter is correct and **Press [2]** to accept it.
8. The All Calls Transfer to Mailbox parameter is the last parameter to be entered. When this entry is completed, the prompt at Step 4 will appear. Continue assigning or editing other mailboxes by repeating Steps 5-7.
9. To return to the Main Menu, **Press [*]** twice.

Deleting a Mailbox

The System Manager must delete the mailboxes that are no longer needed. When another person accesses the VPS, the action is automatically canceled.

1. **Log in** the Main Menu.
2. **Press [6]** for Other Features.
3. **Press [1]** for Mailbox Setup.
4. **Press [2]** for Delete.
5. **Type the mailbox number.**
6. **Press [1]** to delete the mailbox.

Deleting a Mailbox Password

When a password is forgotten, the System Manager must delete the password before it can be reassigned by the subscriber.

1. **Log in** the Main Menu.
2. **Press [6]** for Other Features.
3. **Press [1]** for the Mailbox Setup.
4. **Press [3]** for Password Reset.
5. **Type the mailbox number.**
6. **Press [1]** to delete the password.

C3 SETTING COS (CLASS OF SERVICE) PARAMETERS

Class of Service defines the set of VPS services available to mailbox owners. A maximum of 64 Class of Services can be established. Each Class of Service can be set using the telephone. COS No.63 and No.64 are assigned to the Message Manager and the System Manager respectively.

For a complete explanation of COS parameters, please see Table 39 and Table 40 in B3 SYSTEM ADMINISTRATION—SETTING COS (CLASS OF SERVICE) PARAMETERS.

Follow the steps detailed below to set the following Class of Service parameters:

- **1Personal Greeting Length—Length ranges from 8-60 s in increments of 4 s.*
- *New Message Retention Time—Maximum time is 30 days.*
- *Saved Message Retention Time—Up to 30 days/0: Unlimited.*
- *Message Length—Length ranges from 1-6 min/0: Unlimited.*
- *Number of Messages—The number of messages range from 5-100.*
- *Total Message Time—Total message time ranges from 5-100 min/0: Unlimited.*
- *Message Retrieval Order—Settings are LIFO (Last In First Out) or FIFO (First In First Out).*
- *Message Scanning with Information—Settings are enable or disable.*
- **1Play System Prompt after Personal Greeting—Settings are enable or disable.*
- **1Call Waiting on Busy—Settings are enable or disable.*
- **1Message Cancel for Live Call Screening—Settings are enable or disable.*
- **1Direct Mailbox Access—Settings are enable or disable.*
- **1Intercom Paging Group Number—1-9*
- *Subscriber Service Prompt Mode*
 1. *System Prompt*
 2. *User 1 Prompt*
 3. *User 2 Prompt*
- **2Remote Call Forward to CO—Settings are enable or disable.*
- *Delete Message Confirmation—Settings are enable or disable.*
- **1Number of Caller IDs for Personal Caller Name Announcement—0-30*
- **1Play Personal Greeting for Caller ID—Settings are enable or disable*
- **1Caller ID Screening—Settings are enable or disable*
- **2Message Notification—Settings are enable or disable*
- **1External Message Delivery—Settings are enable or disable*
- **1Auto Forwarding—Settings are enable or disable*

*1 Not available for COS No.63 (Message Manager) and COS No.64 (System Manager)

*2 Not available for COS No.64 (System Manager)

Note

While the System Administrator programs via a personal computer, the System Manager cannot set COS parameters. The VPS plays "Sorry, this function is not available".

1. **Log in** the Main Menu.
2. **Press [6]** for Other Features.
3. **Press [2]** to set Class of Service.
4. **Type the Class of Service Number (1-64).**

Personal Greeting Length

5.
 - a) The current setting plays. **Press [1]** to change the current length.
 - b) **Type the Personal Greeting length (8-60 s).**

Note

The value goes up in increments of 4 s.

- c) Confirm the entry is correct and **Press [2]** to accept it.

New Message Retention Time

6.
 - a) The current setting plays. **Press [1]** to change the current time.
 - b) **Type the retention time (up to 30 days).**
 - c) Confirm the entry is correct and **Press [2]** to accept it.

Saved Message Retention Time

7.
 - a) The current setting plays. **Press [1]** to change the current time.
 - b) **Type the retention time (up to 30 days or 0: unlimited).**
 - c) Confirm the entry is correct and **Press [2]** to accept it.

Message Length

8.
 - a) The current setting plays. **Press [1]** to change the current length.
 - b) Type the **message length (1-6 min or 0: unlimited)**.
 - c) Confirm the entry is correct and **Press [2]** to accept it.

Number of Messages

9.
 - a) The current setting plays. **Press [1]** to change the current number.
 - b) Type the **number of messages (5-100)**.
 - c) Confirm the entry is correct and **Press [2]** to accept it.

Total Message Time

10.
 - a) The current setting plays. **Press [1]** to change the current time.
 - b) Type the **total message time (5-100 min or 0: unlimited)**.
 - c) Confirm the entry is correct and **Press [2]** to accept it.

Message Retrieval Order

11.
 - a) The current setting plays. **Press [1]** to change the current order (LIFO or FIFO).
 - b) Confirm the entry is correct and **Press [2]** to accept it.

Message Scanning with Information

12.
 - a) The current setting plays. **Press [1]** to change the setting (enable or disable).
 - b) Confirm the entry is correct and **Press [2]** to accept it.

Play System Prompt after Personal Greeting

13.
 - a) The current setting plays. **Press [1]** to change the setting (enable or disable).
 - b) Confirm the entry is correct and **Press [2]** to accept it.

Call Waiting on Busy

14.
 - a) The current setting plays. **Press [1]** to change the setting (enable or disable).
 - b) Confirm the entry is correct and **Press [2]** to accept it.

Message Cancel for Live Call Screening

15.
 - a) The current setting plays. **Press [1]** to change the setting (enable or disable).
 - b) Confirm the entry is correct and **Press [2]** to accept it.

Direct Mailbox Access

16.
 - a) The current setting plays. **Press [1]** to change the setting (enable or disable).
 - b) Confirm the entry is correct and **Press [2]** to accept it.

Intercom Paging Group Number

17.
 - a) The current setting plays. **Press [1]** to change the current number.
 - b) **Type the group number (1-9).**
 - c) Confirm the entry is correct and **Press [2]** to accept it.

Note

If set to "9 (Group 9)", the Intercom Paging feature is activated for all groups.

Subscriber Service Prompt Mode

18. **a)** The current setting plays. **Press [1], [2], or [3]** to change the desired mode.
- *[1] System Prompt*
 - *[2] User 1 Prompt*
 - *[3] User 2 Prompt*
- b)** Confirm the entry is correct and **Press [4]** to accept it.

Remote Call Forward to CO

19. **a)** The current setting plays. **Press [1]** to change the setting (enable or disable).
- b)** Confirm the entry is correct and **Press [2]** to accept it.

Delete Message Confirmation

20. **a)** The current setting plays. **Press [1]** to change the setting (enable or disable).
- b)** Confirm the entry is correct and **Press [2]** to accept it.

Number of Caller IDs for Personal Caller Name Announcement

21. **a)** The current setting plays. **Press [1]** to change the current number.
- b)** Type the **number of Caller IDs (0-30)**.
- c)** Confirm the entry is correct and **Press [2]** to accept it.

Play Personal Greeting for Caller ID

22. **a)** The current setting plays. **Press [1]** to change the setting (enable or disable).
- b)** Confirm the entry is correct and **Press [2]** to accept it.

Caller ID Screening

23. a) The current setting plays. **Press [1]** to change the setting (enable or disable).
- b) Confirm the entry is correct and **Press [2]** to accept it.

Message Notification

24. a) The current setting plays. **Press [1]** to change the setting (enable or disable). If the Message Notification is enabled, go to Step 24b below.
- b) **Press [1], [2], [3], [4], or [5]** to choose the desired Beeper Callback Number Entry Mode.
- *[1] Caller Select Mode*
 - *[2] Without message mode*
 - *[3] Before message recording mode*
 - *[4] After message recording mode*
 - *[5] Disable All Entry Mode (Caller cannot access beeper)*
- c) Confirm the entry is correct and **Press [6]** to accept it.
- d) The current setting of MWL Notification for Unreceived Message plays. **Press [1]** to change the setting (enable or disable).
- e) Confirm the entry is correct and **Press [2]** to accept it.
- f) The current setting of Device Notification for Unreceived Message plays. **Press [1]** to change the setting (enable or disable).
- g) Confirm the entry is correct and **Press [2]** to accept it. Return to Step 24a above.

External Message Delivery

25. a) The current setting plays. **Press [1]** to change the setting (enable or disable). If the External Message Delivery is enabled, set the prompt mode for receiving External Delivery Messages (go to Step 25b below).
- b) The current prompt mode plays. **Press [1], [2], [3], or [4]** to choose the desired mode.
- *[1] System Prompt*
 - *[2] User 1 Prompt*
 - *[3] User 2 Prompt*
 - *[4] Selective Prompt*
- c) Confirm the entry is correct and **Press [5]** to accept it. Return to Step 25a above.

Auto Forwarding

26. a) The current setting plays. **Press [1]** to change the setting (enable or disable). If Auto Forwarding is enabled, go to Step 26b below.
- b) The current forwarding destination mailbox number plays. **Press [1]** to change the mailbox number.
- c) **Type the mailbox number.**
- d) Confirm the entry is correct and **Press [2]** to accept it.
- e) The current delay time is played. **Press [1]** to change the setting. The delay time is the period of time that the VPS must wait before forwarding messages. For example, enter 115# to set the delay time to 1 h 15 min; 30# to set 30 min.
- f) Confirm the entry is correct and **Press [2]** to accept it.
- g) The current forwarding mode is played. **Press [1]** to change the setting (copy or move).
- h) Confirm the entry is correct and **Press [2]** to accept it. Return to Step 26a above.

C4 SETTING THE SYSTEM CLOCK

The system clock can be set directly from the telephone. It is important to set the exact time because Message Waiting Notification, External Message Delivery, redialing and rescheduling of External Message Delivery, and Automatic Message Deletion are all scheduled using this setting. The System Administrator and Message Manager are also able to set the clock.

The system automatically adjusts the time as appropriate when daylight saving time begins and ends.

Note

The System Manager cannot set the system clock while:

- *the System Administrator programs via a personal computer,*
- *the Message Manager sets the system clock, records the Voice Labels and System Caller Names, and customizes the Message Manager's Mailbox.*

"The VPS plays Sorry, this function is not available".

1. **Log in** the Main Menu.
2. **Press [6]** for Other Features.
3. **Press [3]** to set the time and date.
4. **Press [1]** to change the current time.
5. **Type the current time** and **Press [#]**.

Note

Press [0] for help. "For example, to enter 5 o'clock, press 5 and # or to enter 5:15, press 5, 1, 5, and #".

6. **Press [1]** for AM or **[2]** for PM.

Note

This selection is not available if "24-h" is selected in "Position of 'AM/PM' in Time Stamp" in Table 58 in B6.5 Prompt Setting.

7. **Press [2]** to accept the time.
8. **Press [1]** to change the current date.
9. **Type the current month** and **Press [#]**.

Note

Press [0] for help. "For example, to enter January, press 1 and #".

- 10. Type the day and Press [#].**
- 11. Type the last 2 digits of the year and Press [#].**
- 12. Press [2] to accept the date.**

C5 CHANGING THE SERVICE MODE SETTING

The VPS automatically activates the appropriate call handling method according to the Time Service setting (Day, Night, Lunch, and Break Services); however, the System Manager or System Administrator can change the current call handling method by selecting a specific Service Mode.

Once the Service Mode has been changed, it is retained unless the System Manager or System Administrator changes it again, even after the power is cut and restored.

Note

While the System Administrator programs via a personal computer, the System Manager cannot change the Service Mode setting. The VPS plays "Sorry, this function is not available".

Assigning the Service Mode

There are 6 Service Modes available:

- *Automatic Mode: Operates according to the setting in Time Service (default)*
- *Manual Day Mode: Operates only in Day Mode*
- *Manual Night Mode: Operates only in Night Mode*
- *Manual Lunch Mode: Operates only in Lunch Mode*
- *Manual Break Mode: Operates only in Break Mode*
- *PBX Control Mode: Operation changes depending on PBX time period (available only with APT/DPT Integration)*

In the Automatic Mode, services have this order of priority:

Holiday Service > Caller ID Call Routing > Trunk Service > Port Service
(Holiday service has the highest priority.)

In the Manual Modes (Day, Night, Lunch, or Break), Holiday Service is disregarded:

Caller ID Call Routing > Trunk Service > Port Service
(Holiday Service is disregarded.)

In the PBX Control Mode: (1) under DPT Integration, the VPS obtains the Time Service (Day, Night, Lunch or Break) setting from the PBX when a call is received through a PBX and operates accordingly; (2) under APT Integration, the VPS obtains the Time Service setting from the PBX when the time period changes at the PBX or APT data link has been established between the VPS and PBX.

When the Integration Mode is other than APT/DPT Integration and the PBX Control Mode is selected, the VPS will operate in the Automatic Mode.

Depending on the model and/or the software version of the connected PBX, the PBX Control

Mode may not function properly. For more information, call National Parts Center at 1-800-833-9626.

Follow the steps below to assign a Service Mode.

- 1. Log in** the main menu.
- 2. Press [6]** for other features.
- 3. Press [4]** to change Service Mode setting.
- 4.** The VPS plays the current setting. **Press [1]** to change the setting.
- 5. Press [1], [2], [3], [4], [5], or [6]** to choose the desired Service Mode entry.
 - *[1] Automatic Mode: Operates according to the setting in Time Service (default)*
 - *[2] Manual Day Mode: Operates only in Day Mode*
 - *[3] Manual Night Mode: Operates only in Night Mode*
 - *[4] Manual Lunch Mode: Operates only in the Lunch Mode*
 - *[5] Manual Break Mode: Operates only in the Break Mode*
 - *[6] PBX Control Mode: Operation changes depending on PBX time period*
- 6.** Confirm the entry is correct and **Press [2]** to accept it.

C6 CHECKING SYSTEM USAGE (SYSTEM REPORTS)

The System Manager can generate 8 System Reports to help monitor the VPS operating status. The reports are sent from the RS-232C port to either a printer or a terminal. (The System Administrator is also able to output System Reports.)

Obtaining System Reports

1. **Log in** the Main Menu.
2. **Press [5]** for the System Report Menu.
3. **Press [1], [2], [3], [4], [5], [6], [7], or [8]** to generate the desired report.

- [1] *System Service Report*
- [2] *Flash Memory Usage Report*
- [3] *Port Usage Report*
- [4] *Mailbox Usage Report*
- [5] *Mailbox Parameter Report*
- [6] *Call Account Report*
- [7] *Class of Service Parameter Report*
- [8] *Fax Call Report*

Note

The Mailbox Parameter Report is displayed as "Mailbox Assignments". The Class of Service Parameter Report is displayed as "COS Assignments".

4. For Flash Memory Usage Report, Port Usage Report, Mailbox Usage Report or Fax Call Report, **Press [1]**. To generate the Mailbox Usage Report, **Go to Step 5**.
5. Mailbox Usage Report—**Type the mailbox number** of the start of the range.

Note

If a [#] is entered in place of each digit of the mailbox numbers (e.g., ### for 3-digit mailbox numbers), reports for all mailboxes will be printed and the System Report Menu will appear. In this case, Step 6 can be skipped.

6. **Press [1]** to specify the mailbox range and **Type the mailbox number** of the end of the range, or **Press [2]** to obtain all mailbox usage counts. This mailbox number is the end of the mailbox range. The mailbox number entered in Step 5 is the start of the range. For

example, to specify the mailbox range 1001 through 1209, enter 1001 in Step 5 and 1209 in Step 6.

Note

While the System Administrator programs via a personal computer, a System Report will not be generated. The System Report starts to be generated after the System Administrator has completed programming and system prompt [>] is displayed on the personal computer.

Clearing the Reports

The Port Usage, Flash Memory Usage, Mailbox Usage, and Fax Call Reports can be cleared.

1. **Log in** in the Main Menu.
2. **Press [5]** for the System Report Menu.
3. **Press [2]** to clear the Flash Memory Usage Reports, **[3]** to clear the Port Usage Reports, **[4]** to clear the Mailbox Usage Reports, or **[8]** to clear the Fax Call Report.
4. **Press [2]** to clear the report. To clear the Mailbox Usage Reports, **Go to Step 5**.
5. **Type the mailbox number** of the start of the range.

Note

If a [#] is entered in place of each digit of the mailbox numbers (e.g., # # # for 3-digit mailbox numbers), reports for all mailboxes will be cleared and the System Report Menu will appear. In this case, Step 6 can be skipped.

6. **Press [1]** to specify the mailbox range, and **Type the mailbox number** of the end of the range. **Press [2]** to clear all Mailbox Usage Reports.

C7 DELIVERING MESSAGES

The System Manager can deliver the same message to all or specified subscribers' mailboxes. When delivering a message to specified mailboxes, he can check the distribution status of each message.

Delivering Messages to All Mailboxes (Broadcasting Messages)

The Broadcasting Messages feature allows the System Manager to deliver the same message to all subscribers at the same time. The message to broadcast is recorded in the System Manager's mailbox. This feature is useful when informing subscribers about the current VPS status such as remaining flash memory capacity, requesting that unnecessary messages be erased, etc.

1. **Log in** the Main Menu.
2. **Press [2]** to deliver a message.
3. **Press [1]** to record a broadcast message.
4. Record a broadcast message and **Press [1]**.
5. **Press [2]** to accept the message recorded.

Delivering Messages to Specified Mailboxes

Use this feature to deliver the same message to one or more subscriber mailboxes by specifying their numbers.

1. **Log in** the Main Menu.
2. **Press [2]** to deliver a message.
3. **Press [2]** to deliver a message.
4. **Type the mailbox number** of the intended recipient.

Note

Enter by name by Pressing [#] [1] first.

Use a System Group Distribution List by specifying its number.

5. Press [2] to accept the number if it is correct.

Note

Press [2] to add mailbox numbers. Press [3] to review the mailing list. Press [] to cancel message transfer.*

6. Press [1] to record a message.

7. Record the message at the tone and Press [1].

8. Press [2] to accept the entry.

9. Press [1] to specify the delivery time and the private status.

Note

Press [2] to send the message immediately and return to the Main Menu.

10. Press [1] to specify the delivery time.

11. Type the time and Press [#].

12. Press [1] for AM or [2] for PM.

Note

This selection is not available if "24-h" is selected in "Position of 'AM/PM' in Time Stamp" in Table 58 in B6.5 Prompt Setting.

13. Type the date (month and day) and Press [#].

14. Press [2] to accept the entry.

15. Press [1] to make this message private; otherwise, Press [2].

Checking Mailbox Distribution

Use this feature to check if messages have been delivered to recipients.

1. **Log in** the Main Menu.
2. **Press [4]** to check distribution status.
3. **Press [3]** to cancel the message or delete verification.

Note

Press [1] to listen to messages. Press [1] twice to check the previous message. Press [2] to check the next message.

4. **Press [1]** to delete verification of this message, or **[2]** to cancel message delivery.

C8 CUSTOMIZING THE SYSTEM MANAGER'S MAILBOX

In order to ensure system security, establish a password consisting of up to 10 numeric characters. Anyone requesting access to the System Manager's service will be required to enter this password before proceeding.

Note

While the System Administrator programs via a personal computer, the System Manager cannot access this service. The VPS plays "Sorry, this function is not available".

1. **Log in** in the Main Menu.
2. **Press [3]** to customize the mailbox.
3. The VPS plays the current password setting. **Press [1]** to change the mailbox password. If a password has not yet been assigned, go to Step 4. **Press [2]** to accept the current setting.
4. **Type the password** and **Press [#]**.

Note

If a password is not needed, Press [#]. It is recommended that the password be set to maintain security.

5. The VPS plays the current password setting. **Press [2]** to accept it.

C9 LISTENING TO SYSTEM MANAGER MESSAGES

1. **Log in** the Main Menu.
2. The VPS plays the number of new messages. **Press [1]** to listen to the messages.
3. The VPS plays each message, identifying the sender and indicating when the message was recorded. **Press [0]** to listen to the entire menu.
 - *[1] Repeat this message*
 - *[1] [1] Replay the Previous Message*
 - *[2] Play the Next Message*
 - *[3] ([1]) Erase this Message*
 - *[4] Reply*
 - *[5] Rewind*
 - *[6] Fast Forward*
 - *[7] Transfer*
 - *[8] Message Scan*

Appendix D
MESSAGE MANAGER'S GUIDE

D1 ACCESSING THE MESSAGE MANAGER'S MAILBOX

The Message Manager's Mailbox must be accessed before performing any Message Manager task. To access the Message Manager's mailbox, three items of information must be known: the telephone number connected directly to the Voice Mail Service, the Message Manager's Mailbox Number, and the Message Manager's Password (if assigned). The Message Manager's Mailbox Number is 98, 998 (default), 9998, or 99998 depending upon the mailbox number length specified in System Programming. The Message Manager's password is assigned through the Message Manager's Service.

To Access the Message Manager's Mailbox

1. **Dial the Extension Number** connected to the Voice Mail Service. Or **Dial any VPS Extension Number and Press [#] [6]** (Service Access Command).

*Please enter your party's mailbox number.
To enter by name, press [#] and [1].
If you are using a rotary telephone, stay on the line.
To call the operator, press [0].*

2. **Press [*]**, then enter the **Message Manager's Mailbox Number** 98, 998, 9998 or 99998.

Enter your password, followed by [#].

3. **Type the Password** followed by [#]. The Main Menu of Message Manager's Service will be played.

*You have (number) new message(s).
To transfer General Delivery Mailbox messages, press [1].
To set up message waiting notification, press [2].
To customize your mailbox, press [3].
To set the clock, press [4].
To modify message, press [5].
To set station call forwarding, press [6].
To end this call, press [*].*

D2 MANAGING THE GENERAL DELIVERY MAILBOX

One of the Message Manager's functions is to check the General Delivery Mailbox for messages and transfer them to the appropriate mailbox or mailboxes (System Group Distribution Lists may be used). This can be done at any time using the telephone.

Listening to Messages

The Message Manager can monitor the status of the General Delivery Mailbox through his mailbox. He can listen to the messages stored in the General Delivery Mailbox and, if necessary, transfer them to their intended recipients.

1. **Log in** the Main Menu.
2. The VPS plays the number of new messages. **Press [1]** to listen to the messages.
3. The VPS plays each message, identifying the sender and indicating when the message was recorded. **Press [0]** to listen to the entire menu.
 - *[1] Repeat this Message*
 - *[1] [1] Replay the Previous Message*
 - *[2] Play the Next Message*
 - *[3] ([1]) Erase this Message*
 - *[4] Reply*
 - *[5] Rewind*
 - *[6] Fast Forward*
 - *[7] Transfer*
 - *[8] Message Scan*

Transferring Messages

Messages left in the General Delivery Mailbox must be transferred to their intended recipients with voice comments attached when necessary. When a message has been transferred, we recommend that the original be deleted from the General Delivery Mailbox.

1. **Log in** the Main Menu.
2. **Press [1]** to transfer messages from the General Delivery Mailbox.

3. The VPS plays the first (next/last) message. **Press [7]** to transfer the message.
4. **Type the destination mailbox number.**
5. **Press [2]** to accept the number.
6. **Press [2]** to transfer with comment.

Note

Press [1] to transfer messages without comment. Press [3] to add a mailbox number.

Press [4] to review the Mailing List.

7. **Record the comments and Press [1].**
8. **Press [2]** to accept the comments entered.

D3 SETTING UP MESSAGE WAITING NOTIFICATION

The VPS can notify the Message Manager when unplayed messages are waiting in his mailbox. Two types of Message Waiting Notification are available: Notification by Message Waiting Lamp and Notification by Calling.

Setting Message Waiting Lamp Status

The VPS illuminates the message waiting lamp on the extension when a new message is recorded in the Message Manager's Mailbox.

Note

The extension assigned for Operator 1 in the Day Mode is the Message Manager's extension. However, its default extension number (0) cannot be used with the Message Waiting Lamp feature. When using this feature, you must assign the extension number that is included in the Extension Numbering Plan.

1. **Log in** the Main Menu.
2. **Press [2]** to set Message Waiting Notification
3. **Press [1]** to change the Message Waiting Lamp Notification Status.
4. **Press [1]** to change the Message Waiting Lamp Notification Status, or **[2]** to accept it.

Setting Notification by Calling Status

The VPS calls the preset telephone or beeper when a new message is recorded in the Message Manager's Mailbox. Set the following parameters as appropriate.

Setting Device Status

For each device, the notification is enabled or disabled according to a preset schedule. The Message Manager cannot **enable** a device according to a schedule. The System Administrator must accomplish this task (see "Time Frame 1, 2" in Table 37 in B2 SYSTEM ADMINISTRATION—MAILBOXES).

1. **Log in** the Main Menu.
2. **Press [2]** to set Message Waiting Notification.
3. **Press [2]** to change the Device Status.
4. **Type the device number (1-3).**

Note

If a telephone number has not been assigned to the selected device number, you cannot set the device status. See "Assigning Notification Numbers" to assign a telephone number.

5. **Press [1], [2], or [3]** to select the device status.
 - [1] *Schedule (enabled on the schedule)*
 - [2] *Continuously (enabled whole day)*
 - [3] *Not Use (disabled whole day)*

Assigning Notification Numbers

Up to 3 telephone or beeper numbers can be set for message notification. Use the number keys 0 to 9, the tone/pulse switch, and the beeper Callback Number Display Entry Code [X] to make these assignments.

When the Beeper Callback No. Entry Code is added at the end of a beeper number, the VPS will ask the caller to enter the callback number that will display on the beeper. System Programming determines if the Callback Number Entry is to be entered before, after, or without the message.

It is also possible to have the caller select whether or not to enter a callback number. The System Manager must authorize the use of the Beeper Callback No. Entry Code.

1. **Log in** the Main Menu.
2. **Press [2]** to set Message Waiting Notification
3. **Press [3]** to assign Telephone Number.
4. **Press [1]** to change the first telephone number, **[2]** to change the second telephone number, or **[3]** to change the third telephone number.
5. **Press [1]** to set the telephone number.

6. Type the telephone number.

7. Press [2] to accept the entry.

- *[1] Change the telephone number*
- *[2] Accept*
- *[3] Review*
- *[4] Add more digits*
- *[5] Insert a pause*
- *[6] Set dial mode*
- *[7] Insert a wait for dial tone*
- *[8] Insert a beeper display command*

8. Press [1] to be notified by telephone or **[2]** by a beeper.

D4 CUSTOMIZING THE MESSAGE MANAGER'S MAILBOX

The Message Manager is able to customize the Message Manager's mailbox by specifying: (1) the password; (2) the extension numbers of Operator 1, 2, and 3; or (3) Telephone numbers 1 and 2 as the call forwarding destinations when Remote Call Forwarding is set to a CO line.

Note

While the System Administrator programs via a personal computer, the Message Manager cannot access this service. The VPS plays "Sorry, this function is not available".

Message Manager's Password

The Message Manager can specify the password at any time using the telephone. The password contains up to 10 numeric characters. It must be entered to execute the message management operation.

Operator's Extensions

When callers require help, they can **Press [0]** on their telephone keypad to be transferred to an operator extension. In each Day, Night, Lunch, and Break Modes, up to 3 operators (Operator 1, 2, 3) can be specified. The extension number assigned for Operator 1 in the Day Mode will be for the Message Manager.

Telephone Numbers 1 and 2 for Remote Call Forward to CO

The customization of the Message Manager's mailbox only allows you to assign Telephone number 1 and/or 2; to enable call forwarding to the telephone number assigned by following the steps below, follow the instructions in D7 REMOTE CALL FORWARDING SET.

If you should change the telephone number after you have enabled call forwarding to a CO line, you must go back to D7 REMOTE CALL FORWARDING SET to reset the call forwarding setting; otherwise, you will be transferring calls to the old telephone number unknowingly.

1. **Log in** the Main Menu.
2. **Press [3]** to customize Mailbox.
3. The VPS plays the current password setting. **Press [1]** to change the password. If a password has not yet been assigned, go to Step 4. **Press [2]** to accept the current setting—**Go to Step 6.**

4. **Type** the password and **Press [#]**.
5. The VPS plays the current password setting. **Press [2]** to accept it.
6. The VPS plays the current operator's extension setting. **Press [1]** to change or assign the operator's extension. **Press [2]** to accept the current setting, or **Press [3]** to delete the current setting—**Go to Step 9**.

Note

Operator 1's extension number cannot be deleted.

7. **Type** the **extension number**.
8. The VPS plays the current extension setting. **Press [2]** to accept it.
9. Repeat Steps 6-8 to assign or to delete the extension number for the Day, Night, Lunch and Break Modes for each operator.
10. The VPS plays the current Telephone number 1 setting. **Press [1]** to change the telephone number. If a telephone number has not yet been assigned, go to Step 11. **Press [2]** to accept the current setting—**Go to Step 13**.
11. **Type** the **telephone number** using "0-9" and "×".

Notes

- *Please make sure you begin the telephone number with a Line Access Code (to seize a CO line).*
- *When connected to the KX-TD816/TD1232/TA1232, the maximum number of characters allowed to be entered is 16.*

12. The VPS plays the current Telephone number 1 setting. **Press [2]** to accept it.
13. The VPS plays the current Telephone number 2 setting. **Press [1]** to change the telephone number. If a telephone number has not yet been assigned, go to Step 14. **Press [2]** to accept the current setting.
14. **Type** the **telephone number** using "0-9" and "×".
15. The VPS plays the current Telephone number 2 setting. **Press [2]** to accept it.

D5 SETTING THE SYSTEM CLOCK

The Message Manager can set the system clock directly from the telephone. It is important to set the exact time because Message Waiting Notification, External Message Delivery, redialing and rescheduling of External Message Delivery, and Automatic Message Deletion are all scheduled using this setting. The System Administrator and System Manager are also able to set the clock.

The system automatically adjusts the time as appropriate when daylight saving time begins and ends.

Note

The Message Manager cannot set the system clock while:

- *the System Administrator programs via a personal computer,*
- *the System Manager sets mailboxes and Class of Service (COS), and customizes the System Manager's Mailbox.*

The VPS plays "Sorry, this function is not available".

1. **Log in** in the Main Menu.
2. **Press [4]** to set the time and date.
3. **Press [1]** to change the current setting.
4. **Type the current time** and **Press [#]**.

Note

Press [0] for help. "For example, to enter 5 o'clock, press 5 and # or to enter 5:15, press 5, 1, 5, and #".

5. **Press [1]** for AM or **[2]** for PM.

Note

This selection is not available if "24-h" is selected in "Position of 'AM/PM' in Time Stamp" in Table 58 in B6.5 Prompt Setting.

6. **Press [2]** to accept the time.
7. **Press [1]** to change the current date.
8. **Type the current month** and **Press [#]**.

Note

Press [0] for help. "For example, to enter January, press 1 and #".

- 9. Type the day and Press [#].**
- 10. Type the last 2 digits of the year and Press [#].**
- 11. Press [2] to accept the date entered.**

D6 RECORDING MESSAGES

The Message Manager is responsible for recording various system messages (specifically: menus, voice labels, user prompts, and system caller names). He is responsible for maintaining the following:

- *The Department Dialing Menu (maximum length: 6 min)—A caller can access departments with the touch of one key. Nine Department Dialing selections (1 to 9) can be recorded.*
- *The Custom Service Menus (maximum length: 6 min each)—Up to 100 custom service menus can be recorded. These menus guide callers to the services they require without the need for a human operator. This is the most useful and powerful feature of your Panasonic Voice Processing System. For example, the Message Manager can record menus in a wide variety of foreign languages.*
- ** The Voice Labels (maximum length: 6 min each)—Up to 20 System Group Distribution Lists can be created by the System Administrator. Each list can have a voice label.*
- *The User Prompts (maximum length: 6 min each)—There are 3 kinds of voice mail prompts: (1) System Prompts, (2) User 1 Prompts, and (3) User 2 Prompts. Generally, the System Prompts should be left alone; they are recorded at the factory in English. However, the Message Manager can record User 1 Prompts and User 2 Prompts in any language he wishes.*
- *The Multilingual Selection Menu (maximum length: 6 min)—With this menu, callers can select the language they prefer to hear all prompts (mentioned in the previous paragraph, "The User Prompts"). For example, the Message Manager can record a menu like this:
For English, press (7).
For French, press (8).
For Chinese, press (9).*
- ** The System Caller Names (maximum length: 4 s each)—Up to 120 Caller ID numbers can be registered by the System Administrator. The Message Manager is responsible for recording a name for each Caller ID number.*
 - * While the System Administrator programs via a personal computer, the Message Manager cannot record the Voice Labels and System Caller Names. The VPS plays "Sorry, this function is not available".

Recording Menus and Voice Labels

1. Log in the Main Menu.

2. Press **[5]** to modify messages.
3. Select the desired number to be recorded.
 - *[3] Record the Department Dialing Menu.*
 - *[4] Record the Custom Service Menus.*
 - *[5] Record the Voice Labels for System Group Distribution Lists.*
 - *[7] Record the Multilingual Selection Menu.*
4. For the item selected in Step 3, follow these steps:
 - For the Department Dialing Menu—**Go to Step 5.**
 - For the Custom Service Menus—**Enter a Custom Service Number (1-100).** Enter [0] to record the Custom Service exit prompt.
 - For the Voice Labels—**Enter a System Group Distribution Lists number to be labeled.** (The System Administrator assigns list numbers.)
 - For the Multilingual Selection Menu—**Go to Step 5.**
5. The VPS plays the current message. Press **[1]** to change the message. If a message has not yet been recorded, go to Step 7.
6. Press **[1]** to record the message. Press **[2]** to erase the current message and return to Step 3 or 4.
7. Record the message at the tone and Press **[1]**.
8. Press **[2]** to accept the message.

Note

 - *Press [1] to review the recorded message.*
 - *Press [3] to erase the recorded message and try again—Return to Step 7.*
 - *Press [4] to add a message.*
 - *Press [*] to erase the recorded message and exit—Return to Step 3.*
9. Repeat Steps 4-8 to record other Custom Service Menus, and/or Voice Labels.

Recording User Prompts

1. Log in the Main Menu.
2. Press **[5]** to modify messages.

3. Press **[6]** to modify user prompts.
4. Press **[1]** to change User Prompt 1, or **[2]** to change User Prompt 2.
5. To change specific prompts, **Go to Step 6.**
To change all prompts in a row without reviewing the current recording, **Go to Step 7.**
6. To change specific prompts:
 - a) Press **[1]**
 - b) Enter the **prompt number** you want to change. (There is a complete list of modifiable prompts in D9 LIST OF MODIFIABLE PROMPTS.)
 - c) The VPS plays the prompt number.
 - d) Press **[1]** to change the prompt. If a prompt has not yet been recorded, the VPS plays the system prompt—go to Step 6g. (If you wish to turn off a certain prompt, please first record a "dummy" prompt. Then go back to Step 6 and you will be able to turn it off by going through these steps.)
 - Note**
 - Press **[2]** to return to Step 6b.
 - e) The VPS plays the current prompt. Press **[1]** to change the prompt.
 - Note**
 - Press **[2]** to retain the current recording—Return to Step 6b.
 - f) Press **[1]** to record a new prompt.
 - Note**
 - Press **[2]** to erase the current recording—Return to Step 6b.
 - Press **[3]** to turn off/on the specified prompt—Return to Step 6b.
 - g) Record a prompt at the tone and Press **[1]** to end recording.
 - h) Press **[2]** to accept the recorded prompt.
 - Note**
 - Press **[1]** to review the recorded prompt.
 - Press **[3]** to erase the recorded prompt and try again—Return to Step 6f.
 - Press **[*]** to erase the recorded prompt and exit—Return to Step 6b.
 - i) Repeat Steps 6b to 6h to record other prompts.
7. To change all prompts in a row:
 - a) Press **[2]**
 - b) Enter the **prompt number** you want to change. (There is a complete list of modifiable prompts in D9 LIST OF MODIFIABLE PROMPTS.)
 - c) The VPS plays the prompt number.

d) Press [1] to change the prompt.

Note

- Press [2] to go to Step 7g.
- Press [3] to turn off/on the prompt.

e) Record a prompt at the tone and Press [1] to end recording.

f) Press [2] to accept the recorded prompt.

Note

- Press [1] to review the recorded prompt.
- Press [3] to erase the recorded prompt and try again—Return to Step 7e.
- Press [*] to erase the recorded prompt and exit—Go to Step 7g.

g) The VPS plays the next prompt number.

h) Repeat Steps 7d to 7g to record other prompts.

Note

User prompts can be saved in a personal computer (command SAVE through the RS-232C). Once they have been saved, they can be restored (with the command LOAD) at any time. There is a complete list of modifiable prompts and prompt numbers in D9 LIST OF MODIFIABLE PROMPTS.

Recording System Caller Names

1. Log in the Main Menu.
2. Press [5] to modify messages.
3. Press [8] to modify system caller names.

4. Enter the Caller ID List Number*¹ (1-120) to be modified.

Note

- *Enter [*] to return to Step 3.*
- *To record system caller names, first Caller ID numbers must be assigned (see B6.6 System Caller Name Announcement).*

5. The VPS plays the Caller ID number and its name. To change the name, Press [1]. If a name has not yet been recorded for this Caller ID number, go to Step 6.

Note

- *Press [2] to accept the current name—Return to Step 4.*
- *Press [3] to erase the current name—Return to Step 4.*

6. Record the name at the tone and Press [1].

7. The VPS plays the recorded name. Press [2] to accept it.

Note

- *Press [1] to change the recorded name—Return to Step 6.*
- *Press [3] to erase the recorded name—Return to Step 4.*

8. Repeat Steps 4-7 to record names for other Caller ID List numbers.

*¹ Guidance is "Caller Name Announcement number".

D7 REMOTE CALL FORWARDING SET

The Message Manager can program his extension (assigned for Operator 1 in the Day Mode) from a remote location to forward various types of calls to a desired extension or an outside telephone. There are six forwarding settings available:

- *FWD All*—Forward all incoming calls to a desired extension number.
- *FWD Busy*—Forward all incoming calls to a desired extension number when the line is busy.
- *FWD No Answer*—Forward all incoming calls to a desired extension number when there is no answer.
- *FWD Busy or No Answer*—Forward all incoming calls to a desired extension number when the line is busy or there is no answer.
- *FWD to CO*—Forward all incoming calls to Telephone number 1 or 2 (preprogrammed in the Mailbox Setting), or to any other telephone number.
- *FWD Cancel*—Cancel the forwarding setting.

Notes:

- *The Remote Call Forwarding Set feature is available with DPT Integration only.*
- *By default, the extension number for the Message Manager's extension (assigned for Operator 1 in the Day Mode) is "0". However, the default setting cannot be used with this feature. When using this feature, you must assign the extension number that is included in the Extension Numbering Plan.*
- *FWD to CO must be enabled in the COS (Class of Service) setting to be utilized (see "Remote Call Forward to CO" in Table 40 in B3 SYSTEM ADMINISTRATION—SETTING COS (CLASS OF SERVICE) PARAMETERS).*

Assigning the Remote Call Forwarding Set

1. **Log in** the Main Menu.
2. **Press [6]** to set Remote Call Forwarding.

3. Press [1], [2], [3], [4], [5], or [6] to select the desired forwarding setting.

- *[1] FWD All*
- *[2] FWD Busy*
- *[3] FWD No Answer*
- *[4] FWD Busy or No Answer*
- *[5] FWD to CO*
- *[6] FWD Cancel*

4. For the items selected in Step 3, follow these steps:

- For FWD All—**Go to Step 5.**
- For FWD Busy—**Go to Step 5.**
- For FWD No Answer—**Go to Step 5.**
- For FWD Busy or No Answer—**Go to Step 5.**
- For FWD to CO—**Go to Step 7.**
- For FWD Cancel—**Go to Step 10.**

5. Type the extension number.

6. Confirm the entry is correct and Press [2] to accept it. Go to Step 11.

Note

Press [1] to change the extension number—Return to Step 5.

7. Press [1] or [2] to select Telephone number 1 or Telephone number 2 (Go to Step 9), or Press [3] to select another telephone number.

8. Type the telephone number using "0-9" and "×".

Notes

- *Please make sure you begin the telephone number with a Line Access Code (to seize a CO line).*
- *When connected to the KX-TD816/TD1232/TA1232, the maximum number of characters allowed to be entered is 16.*

9. Confirm the entry is correct and Press [2] to accept it. Go to Step 11.

Note

Press [1] to change the telephone number. Return to Step 7.

10. Call Forwarding is canceled. Press [2] to accept it.

11. Call Forwarding setting data is transmitted to the PBX. If the forwarding setting or canceling has been completed properly, you will hear: *"Call forwarding accepted"* or *"Call forwarding is canceled"*.

Note

If you hear "Call Forwarding not accepted. Please check the destination number", the forwarding setting has not been completed properly at the PBX, possibly because a nonexistent extension number has been entered as the destination. It is also possible that the model of the connected PBX does not support the Remote Call Forwarding Set, or its software version is lower than required; for more information, call National Parts Center at 1-800-833-9626.

D8 LIST OF PROMPTS FOR VOICE MAIL AND AA SERVICE

There are over 900 voice prompts (all listed in the next section) and they come in 3 types.

- (1) System Prompts—in English (cannot be modified)
- (2) User 1 Prompts—recordable
- (3) User 2 Prompts—recordable

However, in many cases it is not necessary to record all the voice prompts (recording over 900 voice prompts is a big undertaking). When an outside party calls AA service or VM service, he only hears some of the following prompts. **Therefore, it is necessary only to record (or modify) these prompts.** Please change prompts as needed for your application. For example, prompt no. [819] could be *"Thank you for calling ABCD Travel"*, instead of *"Welcome to the Voice Processing System"*. (The maximum length of a prompt is fixed at 6 min.)

Note

To identify the prompt(s) linked to each prompt listed below, refer to the next section, D9 LIST OF MODIFIABLE PROMPTS.

Prompts Common to VM and AA Services

Table 79

Prompt No.	Modifiable Prompts
248	Good afternoon
249	Good evening
250	Good morning
819	Welcome to the Voice Processing System
675	To enter by name, press the pound sign and 1
132	Enter the first 3 or 4 letters of the person's last name
198	For 'Q', press 7
199	For 'Z', press 9
505	Sorry, there are no more matching names
513	Sorry, this name cannot be found
277	Incorrect entry
274	If you are using a rotary telephone, stay on the line
618	To call the operator, press 0
49	Calling the operator

Table 79

Prompt No.	Modifiable Prompts
417	Please wait a moment
818	Welcome to the general delivery mailbox
416	Please leave a message at the tone
668	To end recording, hang up or press 1 for more features
702	To pause and restart recording, press 2
732	To review, press 1
603	To accept, press 2
678	To erase and try again, press 3
614	To add, press 4
677	To erase and exit, press ✕
697	To make this message private, press 1
392	Otherwise, press 2
531	Thank you for calling

VM Prompts**Table 80**

Prompt No.	Modifiable Prompts
413	Please enter your party's mailbox number

AA Prompts**Table 81**

Prompt No.	Modifiable Prompts
412	Please enter your party's extension
825	You have a call
502	Sorry, no one is available to answer the call
695	To leave a message, press 1
672	To enter another extension, press ✕
510	Sorry, this line is busy

Table 81

Prompt No.	Modifiable Prompts
276	If you would like to hold, press 1
622	To cancel holding, press 2 now Otherwise, I'll try your party again

D9 LIST OF MODIFIABLE PROMPTS

The table below shows the modifiable prompts. Record prompts as User 1 or User 2. Some of the modifiable prompts are listed along with their linked prompt number. Whenever possible, record related prompts together so that the assembled sentence flows naturally and sounds like one voice. You can change all service prompts to User 1 or User 2 by changing the DIP Switch setting (see Table 1 in 1.3.2 System Components).

If you wish to change some of service prompts to User 1 or User 2, but not all of them, please see the following sections:

- B3 SYSTEM ADMINISTRATION—SETTING COS (CLASS OF SERVICE) PARAMETERS; "Prompt Mode" of Tables 39 and 40.
- B4 SYSTEM ADMINISTRATION—PORT/TRUNK SERVICE; "Incoming Call Service Prompt" of Tables 41 and 42.
- B5.2 Custom Service; "Prompt Mode" in Table 48.
- B6.5 Prompt Setting; Table 58.

Table 82

Prompt No.	Modifiable Prompts	Linked to Prompt No. (s)
1	20 members maximum	[509], [1]
2	8 members maximum	[509], [2]
3	After hours greeting is (message)	[3]
4	After hours greeting is not recorded	[4]
5	All beeper entry modes are disabled	[5]
6	All calls transfer to mailbox disabled	[6]
7	All calls transfer to mailbox enabled	[7]
8	All mailboxes are assigned	[8]
9	All messages erased	[9]
10	All transfer services disabled	[10]
11	AM	[11]
12	and	[12] [317], [13], [12] [325], [12]
13	and transferred via (mailbox number)	[13] [317], [13], [12]
14	Answer length is (number)	[14], [454]
15	Any digit on the telephone keypad can be used	[15]

Table 82

Prompt No.	Modifiable Prompts	Linked to Prompt No. (s)
16	APRIL	[16]
17	at	[17] [594], [17] [304], [432], [17] [323], [17], [197], [259] [323], [17], [197], [258] [158], [379], [17] [318], [17] [305], [816], [17] [159], [17] [318], [17], [197], [259]
18	(number) attempts were busy	[18]
19	(number) attempts were no answer	[19]
20	(number) attempts were successful	[20]
21	AUGUST	[21]
22	Auto forwarding disabled	[22]
23	Auto forwarding enabled	[23]
24	because message retention time expired	[157], [815], [24]
25	Beeper access disabled	[25]
26	Beeper access enabled	[26]
27	Beeper callback number entry mode is after message recording	[27]
28	Beeper callback number entry mode is before message recording	[28]
29	Beeper callback number entry mode is caller select	[29]
30	Beeper callback number entry mode is without message	[30]
31	being delivered now	[324], [31]
32	Busy signal greeting is (message)	[32]
33	Busy signal greeting is not recorded	[33]
34	Call blocking enabled	[34]

Table 82

Prompt No.	Modifiable Prompts	Linked to Prompt No. (s)
35	Call screening enabled	[35]
36	Call transferred from the voice processing system	[36]
37	CALLBACK NUMBER	[37]
38	Caller ID (number)	[38], [252] [38], [253]
39	Caller ID number and caller name deleted	[39]
40	Caller ID number entries for this box are full, there are 30 entries for caller ID allowed	[40]
41	Caller ID number is (telephone number)	[41] [41], [647], [603]
42	Caller ID number is not assigned	[42] [42], [647], [392]
43	Caller ID numbers assigned	[541], [43]
44	Caller ID screen disabled	[44]
45	Caller ID screen enabled	[45]
46	Caller name is (name)	[46]
47	Caller name is erased	[47]
48	Caller name is not recorded	[48]
49	Calling the operator	[49], [417]
50	Cannot be retrieved	[50]
51	Class of service number is (number)	[51], [583] [51], [584] [51]
52	Company greeting number (number)	[52], [154]
53	Company greeting number is (number)	[53]
54	Company name (name)	[54]
55	Company name erased	[55]
56	Counts cleared	[56]

Table 82

Prompt No.	Modifiable Prompts	Linked to Prompt No. (s)
57	Covering extension is (extension number)	[57]
58	Covering extension not assigned	[58]
59	Covering extension transfer disabled	[59]
60	Covering extension transfer enabled	[60]
61	Custom service menu	[61] [61], [154]
62	Custom service number (number)	[62]
63	Date is (date)	[63]
64	Day mode first operator's extension is (extension number)	[64]
65	Day mode first operator's extension is not assigned	[65]
66	Day mode second operator's extension is (extension number)	[66]
67	Day mode second operator's extension is not assigned	[67]
68	Day mode third operator's extension is (extension number)	[68]
69	Day mode third operator's extension is not assigned	[69]
70	days	[70] [339], [70] [449], [70]
71	DECEMBER	[71]
72	Delay time is (time)	[72], [264], [332] [72], [264] [72], [332]
73	deleted	[289], [73]
74	Delivering message to (name)	[74]
75	Delivery list number is (number)	[75]
76	Department dialing menu erased	[76]
77	Department dialing menu is (menu)	[77]

Table 82

Prompt No.	Modifiable Prompts	Linked to Prompt No. (s)
78	Device notification for unreceived message disabled	[78]
79	Device notification for unreceived message enabled	[79]
80	Device number is (number)	[80]
81	DIAL TONE	[81]
82	digits	[865], [822], [82] [411], [822], [82] [411], [822], [82], [820] [121], [822], [82] [875], [822], [82]
83	Direct mailbox access disabled	[83]
84	Direct mailbox access enabled	[84]
85	EIGHT	[85]
86	EIGHT [HOUR]	[86]
87	EIGHT [MINUTE] (OWE EIGHT)	[87]
88	EIGHTEEN	[88]
89	EIGHTEEN [HOUR]	[89]
90	EIGHTEEN [MINUTE]	[90]
91	EIGHTEENTH	[91]
92	EIGHTH	[92]
93	EIGHTY	[93]
94	EIGHTY EIGHT	[94]
95	EIGHTY FIVE	[95]
96	EIGHTY FOUR	[96]
97	EIGHTY NINE	[97]
98	EIGHTY ONE	[98]
99	EIGHTY SEVEN	[99]
100	EIGHTY SIX	[100]
101	EIGHTY THREE	[101]
102	EIGHTY TWO	[102]

Table 82

Prompt No.	Modifiable Prompts	Linked to Prompt No. (s)
103	ELEVEN	[103]
104	ELEVEN [HOUR]	[104]
105	ELEVEN [MINUTE]	[105]
106	ELEVENTH	[106]
107	Enter 1 for AM, or 2 for PM	[107]
108	Enter a class of service number from 1 to 64	[108]
109	Enter a group number from 1 to 9	[109]
110	Enter a group number, 1 through 4	[110]
111	Enter a mailbox list number	[111]
112	Enter a message length from 1 to 6 minutes	[112]
113	Enter a message retention time up to 30 days	[113]
114	Enter a personal greeting length from 8 to 60 seconds	[114]
115	Enter delivery list number 1 or 2	[115]
116	Enter device number, 1 through 3	[116]
117	Enter extension number	[117]
118	Enter question number, followed by the hash sign	[118]
119	Enter question number, followed by the pound sign	[119]
120	Enter the 4 digits password	[120], [747] [120], [746]
121	Enter the caller ID number	[121], [822], [82]
122	Enter the caller name announcement number 1 through 120	[122]
123	Enter the company greeting number 1 through 32	[123]
124	Enter the custom service prompt number 1 through 100 To record custom service exit prompt, press 0	[124]

Table 82

Prompt No.	Modifiable Prompts	Linked to Prompt No. (s)
125	Enter the day of the month, followed by the hash sign	[125]
126	Enter the day of the month, followed by the pound sign	[126]
127	Enter the day, followed by the hash sign	[127]
128	Enter the day, followed by the pound sign	[128]
129	Enter the delay time, followed by the hash sign	[129]
130	Enter the delay time, followed by the pound sign	[130]
131	Enter the destination mailbox number	[131], [675] [131], [674]
132	Enter the first 3 or 4 letters of the person's last name	[132], [198], [199] [132]
133	Enter the first 4 letters of the owner's last name	[133]
134	Enter the interview mailbox number	[134]
135	Enter the last 2 digits of the year, followed by the hash sign	[135]
136	Enter the last 2 digits of the year, followed by the pound sign	[136]
137	Enter the mailbox number	[137] [137], [812] [137], [813]
138	Enter the maximum number of caller IDs for caller name announce Valid entries are from 0 to 30	[138]
139	Enter the maximum number of messages per mailbox Valid entries are from 5 to 100	[139]
140	Enter the month, followed by the hash sign	[140], [208]
141	Enter the month, followed by the pound sign	[141], [208]

Table 82

Prompt No.	Modifiable Prompts	Linked to Prompt No. (s)
142	Enter the new time, followed by the hash sign	[142], [208]
143	Enter the new time, followed by the pound sign	[143], [208]
144	Enter the operator's extension number	[144]
145	Enter the owner's extension number	[145]
146	Enter the prompt number	[146]
147	Enter the telephone number and wait To insert a pause or special command, enter the partial number and wait for the options menu	[147]
148	Enter the time, followed by the hash sign	[148], [208] [148], [664], [208]
149	Enter the time, followed by the pound sign	[149], [208] [149], [665], [208]
150	Enter the total message time available per mailbox Valid entries are from 5 to 100 minutes	[150]
151	Enter your party's mailbox number	[151], [675] [151], [674]
152	Enter your password, followed by the hash sign	[152] [152], [746]
153	Enter your password, followed by the pound sign	[153] [153], [747]
154	erased	[52], [154] [61], [154]
155	Extension (extension number)	[155]
156	Extension number (extension number)	[156]
157	External delivery message for (name)	[157], [815], [24]
158	External delivery message scheduled for (name)	[158], [379], [17]
159	External delivery message scheduled on (date)	[159], [17]

Table 82

Prompt No.	Modifiable Prompts	Linked to Prompt No. (s)
160	External delivery message will be sent right away	[160]
161	External delivery message will be sent to (name)	[161], [447]
162	External message delivery disabled	[162]
163	External message delivery enabled	[163]
164	FAX messages	[824], [164]
165	FEBRUARY	[165]
166	FIFTEEN	[166]
167	FIFTEEN [HOUR]	[167]
168	FIFTEEN [MINUTE]	[168]
169	FIFTEENTH	[169]
170	FIFTH	[170]
171	FIFTY	[171]
172	FIFTY [MINUTE]	[172]
173	FIFTY EIGHT	[173]
174	FIFTY EIGHT [MINUTE]	[174]
175	FIFTY FIVE	[175]
176	FIFTY FIVE [MINUTE]	[176]
177	FIFTY FOUR	[177]
178	FIFTY FOUR [MINUTE]	[178]
179	FIFTY NINE	[179]
180	FIFTY NINE [MINUTE]	[180]
181	FIFTY ONE	[181]
182	FIFTY ONE [MINUTE]	[182]
183	FIFTY SEVEN	[183]
184	FIFTY SEVEN [MINUTE]	[184]
185	FIFTY SIX	[185]
186	FIFTY SIX [MINUTE]	[186]
187	FIFTY THREE	[187]
188	FIFTY THREE [MINUTE]	[188]

Table 82

Prompt No.	Modifiable Prompts	Linked to Prompt No. (s)
189	FIFTY TWO	[189]
190	FIFTY TWO [MINUTE]	[190]
191	FIRST	[191]
192	First telephone number is (telephone number)	[192]
193	First telephone number is not assigned	[193]
194	FIVE	[194]
195	FIVE [HOUR]	[195]
196	FIVE [MINUTE] (OWE FIVE)	[196]
197	for	[197] [323], [17], [197], [259] [323], [17], [197], [258] [318], [17], [197], [259]
198	For 'Q', press 7	[132], [198], [199]
199	For 'Z', press 9	[132], [198], [199]
200	For a system report, press 5	[711], [663], [652], [649], [200], [212], [670]
201	For automated attendant status, press 4	[711], [663], [648], [201], [210], [212], [670] [711], [663], [648], [201], [210], [670]
202	For department dialing, press *	[412], [675], [202] [412], [674], [202]
203	For example, to enter 5 o'clock press 5 and the hash sign, or to enter 5:15 press 5, 1, 5 and the hash sign	[203]
204	For example, to enter 5 o'clock press 5 and the pound sign, or to enter 5:15 press 5, 1, 5 and the pound sign	[204]
205	For example, to enter January, press 1 and the hash sign	[205]
206	For example, to enter January, press 1 and the pound sign	[206]
207	For external message delivery, press 3	[207]

Table 82

Prompt No.	Modifiable Prompts	Linked to Prompt No. (s)
208	For help, press 0	[149], [208] [149], [665], [208] [717], [706], [679], [726], [753], [208] [717], [706], [679], [753], [208] [143], [208] [141], [208] [148], [208] [148], [664], [208] [142], [208] [140], [208]
209	For interview mailbox management, press 1	[209]
210	For mailbox management, press 5	[711], [663], [648], [201], [210], [212], [670] [711], [663], [648], [201], [210], [670]
211	For notification by telephone, press 1 For notification by beeper, press 2	[211]
212	For other features, press 6	[711], [663], [648], [201], [210], [212], [670] [711], [663], [652], [649], [200], [212], [670]
213	For the next name, press 2	[602], [213], [718], [671]
214	FORTY	[214]
215	FORTY [MINUTE]	[215]
216	FORTY EIGHT	[216]
217	FORTY EIGHT [MINUTE]	[217]
218	FORTY FIVE	[218]
219	FORTY FIVE [MINUTE]	[219]
220	FORTY FOUR	[220]
221	FORTY FOUR [MINUTE]	[221]
222	FORTY NINE	[222]
223	FORTY NINE [MINUTE]	[223]
224	FORTY ONE	[224]
225	FORTY ONE [MINUTE]	[225]
226	FORTY SEVEN	[226]
227	FORTY SEVEN [MINUTE]	[227]

Table 82

Prompt No.	Modifiable Prompts	Linked to Prompt No. (s)
228	FORTY SIX	[228]
229	FORTY SIX [MINUTE]	[229]
230	FORTY THREE	[230]
231	FORTY THREE [MINUTE]	[231]
232	FORTY TWO	[232]
233	FORTY TWO [MINUTE]	[233]
234	Forwarding mailbox number is (mailbox number)	[234]
235	Forwarding mailbox number is not assigned	[235]
236	Forwarding mode is copy	[236]
237	Forwarding mode is move	[237]
238	FOUR	[238]
239	FOUR [HOUR]	[239]
240	FOUR [MINUTE] (OWE FOUR)	[240]
241	FOURTEEN	[241]
242	FOURTEEN [HOUR]	[242]
243	FOURTEEN [MINUTE]	[243]
244	FOURTEENTH	[244]
245	FOURTH	[245]
246	FRIDAY	[246]
247	from (name)	[575], [247] [266], [247] [267], [247]
248	Good afternoon	[248], [819] [248]
249	Good evening	[249], [819] [249]
250	Good morning	[250], [819] [250]
251	Greeting erased	[251]
252	greeting is (message)	[38], [252]

Table 82

Prompt No.	Modifiable Prompts	Linked to Prompt No. (s)
253	greeting is not recorded	[38], [253]
254	Group member deleted	[254]
255	Group name erased	[255]
256	Group name not recorded	[256]
257	Group number (number)	[257]
258	has been erased, because message retention time expired	[323], [17], [197], [258]
259	has not been received	[323], [17], [197], [259] [318], [17], [197], [259]
260	HASH(#)	[260]
261	Hello, this is the voice processing system	[261]
262	(Not available)	
263	Hello, this is voice processing system with the following information More than 80% of flash memory space is now utilized Please erase unnecessary messages	[263]
264	hours (time)	[72], [264], [332] [72], [264]
265	HUNDRED	[265]
266	I have a call for (name)	[266] [266], [247]
267	I have a call for mailbox (mailbox number)	[267] [267], [247]
268	I have a message for (name)	[268], [711], [690] [268], [711], [690], [275]
269	I was unable to reach (name)	[269]
270	I'll notify by beeper	[270]
271	I'll notify by telephone	[271]
272	I'll redial (number)	[272], [337]
273	I'll redial only once	[273]

Table 82

Prompt No.	Modifiable Prompts	Linked to Prompt No. (s)
274	If you are using a rotary telephone, stay on the line	[274], [618] [274]
275	If you want me to call back later, press 3	[268], [711], [690], [275]
276	If you would like to hold, press 1	[276], [392]
277	Incorrect entry	[277]
278	Intercom paging disabled	[278]
279	Intercom paging enabled	[279]
280	Intercom paging group number is (number)	[280]
281	Interview mailbox number is (mailbox number)	[281]
282	Interview mailbox number is deleted	[282]
283	Interview mailbox number is not assigned	[283]
284	JANUARY	[284]
285	JULY	[285]
286	JUNE	[286]
287	Leaving a message is disabled	[287]
288	Leaving a message is enabled	[288]
289	Mailbox	[289] [289], [73]
290	Mailbox is in use	[290]
291	Mailbox list label erased	[291]
292	Mailbox list number (number)	[292]
293	Mailbox number already specified	[293]
294	MARCH	[294]
295	Maximum number of caller IDs for caller name announce is (number)	[295]
296	Maximum number of messages per mailbox is (number)	[296]
297	MAY	[297]

Table 82

Prompt No.	Modifiable Prompts	Linked to Prompt No. (s)
298	Message back up disabled	[298]
299	Message back up enabled	[299]
300	Message cancel for live call screening disabled	[300]
301	Message cancel for live call screening enabled	[301]
302	Message delivery canceled	[302]
303	Message erased	[303]
304	Message for (name)	[304], [432], [17]
305	Message from (name)	[305], [816], [17]
306	Message from the interview mailbox	[306]
307	Message from the message manager	[307]
308	Message from the system manager	[308]
309	Message length is (time)	[309], [332]
310	Message Manager	[310]
311	Message notification disabled	[311]
312	Message notification enabled	[312]
313	Message reception mode is interview mode	[313]
314	Message reception mode is message recording mode	[314]
315	Message reception mode is set to interview mode	[315]
316	Message reception mode is set to message recording mode	[316]
317	Message recorded by (mailbox number)	[317], [13], [12]
318	Message recorded on (date)	[318], [17] [318], [17], [197], [259]
319	Message retrieval order is first-in-first-out	[319]
320	Message retrieval order is last-in-first-out	[320]

Table 82

Prompt No.	Modifiable Prompts	Linked to Prompt No. (s)
321	Message scanning with information is disabled	[321]
322	Message scanning with information is enabled	[322]
323	Message sent on (date)	[323], [17], [197], [259] [323], [17], [197], [258]
324	Message to (name)	[324], [31]
325	Message transferred via (mailbox number)	[325], [12]
326	Message waiting lamp notification disabled	[326]
327	Message waiting lamp notification enabled	[327]
328	Message waiting lamp notification for unreceived message disabled	[328]
329	Message waiting lamp notification for unreceived message enabled	[329]
330	Messages	[330] [824], [330]
331	(number) messages to verify	[331]
332	minutes	[332] [309], [332] [763], [332] [72], [264], [332] [72], [332]
333	MONDAY	[333]
334	more caller ID numbers	[821], [334]
335	more members	[821], [335]
336	MORE THAN ONE HUNDRED	[336]
337	more times	[272], [337]
338	New message	[338]
339	New message retention time is (day)	[339], [70]
340	new messages	[824], [340]

Table 82

Prompt No.	Modifiable Prompts	Linked to Prompt No. (s)
341	Night mode first operator's extension is (extension number)	[341]
342	Night mode first operator's extension is not assigned	[342]
343	Night mode second operator's extension is (extension number)	[343]
344	Night mode second operator's extension is not assigned	[344]
345	Night mode third operator's extension is (extension number)	[345]
346	Night mode third operator's extension is not assigned	[346]
347	NINE	[347]
348	NINE [HOUR]	[348]
349	NINE [MINUTE] (OWE NINE)	[349]
350	NINETEEN	[350]
351	NINETEEN [HOUR]	[351]
352	NINETEEN [MINUTE]	[352]
353	NINETEENTH	[353]
354	NINETY	[354]
355	NINETY EIGHT	[355]
356	NINETY FIVE	[356]
357	NINETY FOUR	[357]
358	NINETY NINE	[358]
359	NINETY ONE	[359]
360	NINETY SEVEN	[360]
361	NINETY SIX	[361]
362	NINETY THREE	[362]
363	NINETY TWO	[363]
364	NINTH	[364]
365	No answer greeting is (message)	[365]
366	No answer greeting is not recorded	[366]

Table 82

Prompt No.	Modifiable Prompts	Linked to Prompt No. (s)
367	No external delivery message pending	[367]
368	No letters have been specified	[368]
369	No messages to verify	[369]
370	No more messages	[370]
371	No one specified by this number	[371]
372	No previous message	[372]
373	No question recorded	[373]
374	NOVEMBER	[374]
375	O'CLOCK	[375]
376	OCTOBER	[376]
377	of (company name)	[592], [377]
378	Old message	[378]
379	on (date)	[158], [379], [17]
380	ONE	[380]
381	ONE [HOUR]	[381]
382	ONE [MINUTE] (OWE ONE)	[382]
383	One attempt was busy	[383]
384	One attempt was no answer	[384]
385	One attempt was successful	[385]
386	One message to verify	[386]
387	One other person is waiting to connect	[387]
388	Only extension call is available	[499], [388], [415]
389	Operator transfer disabled	[389]
390	Operator transfer enabled	[390]
391	(number) other people are waiting to connect	[391]

Table 82

Prompt No.	Modifiable Prompts	Linked to Prompt No. (s)
392	Otherwise, press 2	[676], [392] [697], [392] [532], [647], [392] [651], [392] [276], [392] [533], [647], [392] [654], [392] [720], [392] [653], [392] [42], [647], [392]
393	Owner's extension is (extension number)	[393]
394	Owner's extension is not assigned	[394]
395	Owner's extension number is deleted	[395]
396	Owner's name erased	[396]
397	Owner's name is (name)	[397]
398	Owner's name is deleted	[398]
399	Owner's name is not recorded	[399]
400	Password deleted	[400]
401	Password entry failure Check the password	[401]
402	Password is (number)	[402]
403	Password not assigned	[403]
404	PAUSE	[404]
405	Personal greeting for caller ID disabled	[405]
406	Personal greeting for caller ID enabled	[406]
407	Personal greeting length is (time)	[407], [454]
408	Play system prompt after personal greeting disabled	[408]
409	Play system prompt after personal greeting enabled	[409]
410	Please call (telephone number)	[410]

Table 82

Prompt No.	Modifiable Prompts	Linked to Prompt No. (s)
411	Please enter your callback number	[411], [822], [82] [411], [822], [82], [820]
412	Please enter your party's extension	[412], [675] [412], [675], [202] [412], [674] [412],[674],[202]
413	Please enter your party's mailbox number	[413], [675] [413], [675], [618] [413], [674] [413], [674], [618]
414	Please hold while I page your party	[414]
415	Please inform system manager	[508], [415] [499], [388], [415]
416	Please leave a message at the tone	[416]
417	Please wait a moment	[417] [49], [417]
418	PM	[418]
419	POUND(#)	[419]
420	Prompt mode for external message delivery is caller select	[420]
421	Prompt mode for external message delivery is system	[421]
422	Prompt mode for external message delivery is user 1	[422]
423	Prompt mode for external message delivery is user 2	[423]
424	Prompt mode is system	[424]
425	Prompt mode is user 1	[425]
426	Prompt mode is user 2	[426]
427	Prompt number (number)	[427]
428	Prompt restored	[428]
429	PULSE DIALING MODE	[429]
430	Question erased	[430]

Table 82

Prompt No.	Modifiable Prompts	Linked to Prompt No. (s)
431	Question number (number)	[431]
432	received on (date)	[304], [432], [17]
433	Record caller name at the tone	[433]
434	Record company name at the tone	[434]
435	Record greeting at the tone	[435]
436	Record label at the tone	[436]
437	Record menu at the tone	[437]
438	Record owner's name at the tone	[438]
439	Record the group name at the tone	[439]
440	Record the prompt at the tone	[440]
441	Record the question at the tone	[441]
442	Record the recipient's name at the tone	[442]
443	Record your name at the tone	[443]
444	Recording accepted	[444]
445	Returning to top menu automated attendant service disabled	[445]
446	Returning to top menu automated attendant service enabled	[446]
447	right away	[161], [447]
448	SATURDAY	[448]
449	Saved message retention time is (day)	[449], [70]
450	Saved message retention time is unlimited	[450]
451	SECOND	[451]
452	Second telephone number is (telephone number)	[452]
453	Second telephone number is not assigned	[453]
454	seconds	[454] [14], [454] [407], [454]

Table 82

Prompt No.	Modifiable Prompts	Linked to Prompt No. (s)
455	Selection Menu	[455]
456	Selection menu erased	[456]
457	Selection menu is (selection menu)	[457]
458	Sending report now to terminal or printer connected to RS-232C port	[458]
459	SEPTEMBER	[459]
460	Set the answer length using the following options For 4 seconds, press 1 For 8 seconds, press 2 For 16 seconds, press 3 For 32 seconds, press 4	[460]
461	SEVEN	[461]
462	SEVEN [HOUR]	[462]
463	SEVEN [MINUTE] (OWE SEVEN)	[463]
464	SEVENTEEN	[464]
465	SEVENTEEN [HOUR]	[465]
466	SEVENTEEN [MINUTE]	[466]
467	SEVENTEENTH	[467]
468	SEVENTH	[468]
469	SEVENTY	[469]
470	SEVENTY EIGHT	[470]
471	SEVENTY FIVE	[471]
472	SEVENTY FOUR	[472]
473	SEVENTY NINE	[473]
474	SEVENTY ONE	[474]
475	SEVENTY SEVEN	[475]
476	SEVENTY SIX	[476]
477	SEVENTY THREE	[477]
478	SEVENTY TWO	[478]
479	SIX	[479]
480	SIX [HOUR]	[480]

Table 82

Prompt No.	Modifiable Prompts	Linked to Prompt No. (s)
481	SIX [MINUTE] (OWE SIX)	[481]
482	SIXTEEN	[482]
483	SIXTEEN [HOUR]	[483]
484	SIXTEEN [MINUTE]	[484]
485	SIXTEENTH	[485]
486	SIXTH	[486]
487	SIXTY	[487]
488	SIXTY EIGHT	[488]
489	SIXTY FIVE	[489]
490	SIXTY FOUR	[490]
491	SIXTY NINE	[491]
492	SIXTY ONE	[492]
493	SIXTY SEVEN	[493]
494	SIXTY SIX	[494]
495	SIXTY THREE	[495]
496	SIXTY TWO	[496]
497	Sorry	[497]
498	Sorry, I cannot add any more	[498]
499	Sorry, I cannot call this number	[499], [388], [415]
500	Sorry, mailbox in use, cannot be deleted	[500]
501	Sorry, maximum of 20 destinations exceeded	[501]
502	Sorry, no one is available to answer the call	[502]
503	Sorry, no space for recording	[503]
504	Sorry, Operator is not available to answer the call Please call back later	[504]
505	Sorry, there are no more matching names	[505] [505], [756]
506	Sorry, there is no space for recording	[506]

Table 82

Prompt No.	Modifiable Prompts	Linked to Prompt No. (s)
507	Sorry, there is no space for recording in this mailbox	[507]
508	Sorry, this function is not available	[508], [415] [508]
509	Sorry, this group is full	[509], [2] [509], [1]
510	Sorry, this line is busy	[510]
511	Sorry, this list is in use for delivery If this list is edited, all the deliveries will then be canceled	[511]
512	Sorry, this mailbox is in use	[512]
513	Sorry, this name cannot be found	[513]
514	Sorry, this number is not assigned	[514]
515	Sorry, this pager is not available	[515]
516	Sorry, this report is not available	[516]
517	Sorry, you cannot deliver the message The maximum number of delivery has already been reached	[517]
518	Sorry, you cannot reply	[518], [538] [518], [593] [518], [589]
519	Sorry, you cannot transfer a private message	[519]
520	STAR(✕)	[520]
521	State your comment at the tone	[521], [669], [702]
522	SUNDAY	[522]
523	Telephone number deleted	[523]
524	Telephone number is (telephone number)	[524]
525	Telephone number is not assigned	[525]
526	TEN	[526]
527	TEN [HOUR]	[527]
528	TEN [MINUTE]	[528]

Table 82

Prompt No.	Modifiable Prompts	Linked to Prompt No. (s)
529	TENTH	[529]
530	Thank you	[530]
531	Thank you for calling	[531]
532	The callback number is (telephone number)	[532], [647], [392]
533	The callback number is not assigned	[533], [647], [392]
534	The FAX transfer situation is as follows	[534]
535	The first 4 letters of the owner's last name are (name)	[535]
536	The mailbox number entry failure Check the mailbox number	[536]
537	The message is (message)	[537]
538	The message sender is unknown	[518], [538]
539	The prompt is now turned off	[539]
540	The system-reserved mailbox cannot be edited	[540]
541	There are (number)	[541], [43]
542	There are no messages	[542]
543	There was 1 unsuccessful attempt to enter this mailbox	[543]
544	There were (number of failure)	[544], [809]
545	These are the brief segments of your Message	[545]
546	THIRD	[546]
547	Third telephone number is (telephone number)	[547]
548	Third telephone number is not assigned	[548]
549	THIRTEEN	[549]
550	THIRTEEN [HOUR]	[550]
551	THIRTEEN [MINUTE]	[551]
552	THIRTEENTH	[552]

Table 82

Prompt No.	Modifiable Prompts	Linked to Prompt No. (s)
553	THIRTIETH	[553]
554	THIRTY	[554]
555	THIRTY [MINUTE]	[555]
556	THIRTY EIGHT	[556]
557	THIRTY EIGHT [MINUTE]	[557]
558	THIRTY FIRST	[558]
559	THIRTY FIVE	[559]
560	THIRTY FIVE [MINUTE]	[560]
561	THIRTY FOUR	[561]
562	THIRTY FOUR [MINUTE]	[562]
563	THIRTY NINE	[563]
564	THIRTY NINE [MINUTE]	[564]
565	THIRTY ONE	[565]
566	THIRTY ONE [MINUTE]	[566]
567	THIRTY SEVEN	[567]
568	THIRTY SEVEN [MINUTE]	[568]
569	THIRTY SIX	[569]
570	THIRTY SIX [MINUTE]	[570]
571	THIRTY THREE	[571]
572	THIRTY THREE [MINUTE]	[572]
573	THIRTY TWO	[573]
574	THIRTY TWO [MINUTE]	[574]
575	This call is for (name)	[575] [575], [247]
576	This call is from (name)	[576]
577	This caller ID number already exists	[577]
578	This device is for continuous use	[578]
579	This device is for scheduled use	[579]
580	This device is not to be used	[580]
581	This group has no members	[581]

Table 82

Prompt No.	Modifiable Prompts	Linked to Prompt No. (s)
582	This is a new mailbox	[582]
583	This is for message manager	[51], [583]
584	This is for system manager	[51], [584]
585	This is the General Delivery Mailbox	[585]
586	This is the last message	[586]
587	This is the last prompt number	[587]
588	This is your mailbox	[588]
589	This is your message	[518], [589]
590	This list member already exists	[590]
591	This mailbox number is already assigned	[591]
592	This message is from (name)	[592], [377] [592]
593	This message is from the general delivery mailbox	[518], [593]
594	This message will be delivered on (day)	[594], [17]
595	THREE	[595]
596	THREE [HOUR]	[596]
597	THREE [MINUTE]	[597]
598	THURSDAY	[598]
599	Time is (time)	[599]
600	times	[764], [600]
601	To accept the prompt, press 2	[732], [601], [678], [677]
602	To accept, press 1	[602], [213], [718], [671]

Table 82

Prompt No.	Modifiable Prompts	Linked to Prompt No. (s)
603	To accept, press 2	[732], [603], [678], [614], [677] [738], [603] [647], [603] [732], [603], [678] [639], [603], [733] [647], [603], [661] [647], [603], [682] [647], [603], [733], [608], [692], [740], [693] [647], [603], [733], [608], [692], [740], [693], [691] [647], [603], [721] [647], [603], [733], [608], [692], [693] [647], [603], [733], [608], [692], [693], [691] [41], [647], [603]
604	To accept, press 4	[612], [660], [733], [604] [759], [760], [761], [604]
605	To accept, press 5	[759], [760], [761], [696], [605]
606	To add group members, press 2	[626], [606] [626], [606], [656], [731]
607	To add more caller ID numbers, press 1 To end, press 2	[607]
608	To add more digits, press 4	[647], [603], [733], [608], [692], [740], [693] [647], [603], [733], [608], [692], [740], [693], [691] [647], [603], [733], [608], [692], [693] [647], [603], [733], [608], [692], [693], [691]
609	To add more members, press 1 To end, press 2	[609]
610	To add new mailbox number, press 3	[755], [610], [730] [755], [754], [610], [730]
611	To add new member, press 1	[611] [611], [657], [733]

Table 82

Prompt No.	Modifiable Prompts	Linked to Prompt No. (s)
612	To add, press 1	[612] [612], [660], [733] [612], [660], [733], [604] [612], [907], [661], [908]
613	To add, press 2	[647], [613]
614	To add, press 4	[732], [603], [678], [614], [677]
615	To answer the call, press 1 Otherwise, press 2 and hang up	[615]
616	To assign or edit mailboxes, press 1 To delete mailboxes, press 2 To reset mailbox passwords, press 3	[616]
617	To call message sender, press 1 To record a message, press 2	[617]
618	To call the operator, press 0	[274], [618] [413], [675], [618] [618] [413], [674], [618]
619	To call this person, press 1	[619], [645], [756]
620	To cancel , press ✕ To continue, press 1	[620]
621	To cancel external message delivery, press 1	[621], [642]
622	To cancel holding, press 2 now Otherwise, I'll try your party again	[622]
623	To cancel mailing list review, press any key	[623]
624	To cancel this message or verification, press 3	[624]
625	To change caller ID greeting number 1, press 1 To change caller ID greeting number 2, press 2 To change caller ID greeting number 3, press 3 To change caller ID greeting number 4, press 4	[625]
626	To change group name, press 1	[626], [606] [626], [606], [656], [731]

Table 82

Prompt No.	Modifiable Prompts	Linked to Prompt No. (s)
627	To change the answer length, press 1	[627], [748], [749], [689]
628	To change the caller name and number, press 5	[637], [636], [634], [743], [628] [637], [636], [634], [743], [628], [869]
629	To change the department dialing menu, press 3 To change the custom service menu, press 4 To change the voice label, press 5 To modify the user prompt, press 6 To change the selection menu, press 7 To change the system caller name announcement, press 8	[629]
630	To change the first telephone number, press 1 To change the second telephone number, press 2 To change the third telephone number, press 3	[630]
631	To change the message waiting lamp status, press 1 To change the device status, press 2 To assign the telephone or beeper numbers, press 3	[631]
632	To change the no answer greeting, press 1 To change the busy signal greeting, press 2 To change the after hours greeting, press 3	[632]
633	To change the no answer greeting, press 1 To change the busy signal greeting, press 2 To change the after hours greeting, press 3 To change the caller ID greetings, press 4	[633]
634	To change the owner's name, press 3	[637], [636], [634], [743] [637], [636], [634], [743], [628] [637], [636], [634], [743], [628], [869]
635	To change the password, press 1	[635], [642]

Table 82

Prompt No.	Modifiable Prompts	Linked to Prompt No. (s)
636	To change the password, press 2	[641], [636], [638], [643] [637], [636], [634], [743] [637], [636], [634], [743], [628] [637], [636], [634], [743], [628], [869]
637	To change the personal greeting, press 1	[637], [636], [634], [743] [637], [636], [634], [743], [628] [637], [636], [634], [743], [628], [869]
638	To change the recipient's name, press 3	[641], [636], [638], [643]
639	To change the setting, press 1	[639], [603], [733]
640	To change the specified prompt, press 1 To change all prompts, press 2	[640]
641	To change the telephone number, press 1	[641], [636], [638], [643]
642	To change the time and date, press 2	[635], [642] [621], [642]
643	To change the time and date, press 4	[641], [636], [638], [643]
644	To change this question, press 1	[644], [748], [749], [689]
645	To change to the next person, press 2	[619], [645], [756]
646	To change user prompt 1, press 1 To change user prompt 2, press 2	[646]

Table 82

Prompt No.	Modifiable Prompts	Linked to Prompt No. (s)
647	To change, press 1	[647], [603] [532], [647], [392] [533], [647], [392] [647], [603], [661] [647], [603], [682] [647], [603], [733], [608], [692], [740], [693] [647], [603], [733], [608], [692], [740], [693], [691] [647], [613] [647], [603], [721] [647], [603], [733], [608], [692], [693] [647], [603], [733], [608], [692], [693], [691] [42], [647], [392] [41], [647], [603] [647], [750], [757] [647], [750] [647], [750], [911]
648	To check the mailbox distribution, press 3	[711], [663], [648], [201], [210], [212], [670] [711], [663], [648], [201], [210], [670]
649	To check the mailbox distribution, press 4	[711], [663], [652], [649], [200], [212], [670]
650	To clear all mailbox usage counts, press 2	[751], [650]
651	To continue holding, press 1	[651], [392]
652	To customize your mailbox, press 3	[752], [745], [652], [742], [699], [670] [752], [745], [652], [742], [699], [868], [670] [711], [663], [652], [649], [200], [212], [670]
653	To delete all caller ID numbers, press 1	[653], [392]
654	To delete all group members, press 1	[654], [392]
655	To delete distribution verification of this message, press 1 To cancel message delivery, press 2	[655]
656	To delete group members, press 3	[626], [606], [656], [731]
657	To delete members, press 2	[611], [657], [733]

Table 82

Prompt No.	Modifiable Prompts	Linked to Prompt No. (s)
658	To delete the password, press 1	[658], [694]
659	To delete, press 1	[659], [708] [659], [705] [659], [694]
660	To delete, press 2	[612], [660], [733] [612], [660], [733], [604]
661	To delete, press 3	[647], [603], [661] [612], [907], [661], [908]
662	To deliver a broadcast message, press 1	[662], [663]
663	To deliver a message, press 2	[711], [663], [648], [201], [210], [212], [670] [711], [663], [648], [201], [210], [670] [711], [663], [652], [649], [200], [212], [670] [662], [663]
664	To deliver now, press only the hash sign	[148], [664], [208]
665	To deliver now, press only the pound sign	[149], [665], [208]
666	To enable call blocking, press 1 To enable call screening, press 2 To enable intercom paging, press 3 To enable beeper access, press 4 To disable all transfer service, press 5	[666]
667	To end recording, hang up To cancel your message, press *, if you have a touch tone phone	[667]
668	To end recording, hang up or press 1 for more features	[668], [702]
669	To end recording, press 1	[669], [702] [669] [521], [669], [702]

Table 82

Prompt No.	Modifiable Prompts	Linked to Prompt No. (s)
670	To end this call, press *	[717], [725], [670] [717], [725], [734], [683], [670] [720], [670] [711], [663], [648], [201], [210], [212], [670] [711], [663], [648], [201], [210], [670] [752], [745], [652], [742], [699], [670] [752], [745], [652], [699], [868], [670] [711], [663], [652], [649], [200], [212], [670]
671	To enter a new name or mailbox, press *	[602], [213], [718], [671]
672	To enter another extension, press *	[672]
673	To enter another extension, press 2	[695], [673]
674	To enter by name, press the hash sign and 1	[413], [674] [413], [674], [618] [412], [674] [412], [674], [202] [151], [674] [131], [674]
675	To enter by name, press the pound sign and 1	[413], [675] [413], [675], [618] [412], [675] [412], [675], [202] [151], [675] [131], [675]
676	To enter your callback number, press 1	[676], [392]
677	To erase and exit, press *	[732], [603], [678], [614], [677] [732], [601], [678], [677]
678	To erase and try again, press 3	[732], [603], [678], [614], [677] [732], [601], [678], [677] [732], [603], [678]

Table 82

Prompt No.	Modifiable Prompts	Linked to Prompt No. (s)
679	To erase this message, press 3	[717], [706], [679], [726], [753], [208] [717], [724], [706], [679], [726], [734], [683], [753], [698] [717], [706], [679], [753], [208] [717], [724], [706], [679], [734], [683], [753], [698]
680	To erase this prompt and use system prompt, press 2	[714], [680], [757] [714], [680], [911]
681	To erase this question, press 1	[681], [748], [749], [689]
682	To erase, press 3	[647], [603], [682]
683	To fast forward, press 6	[717], [725], [734], [683], [670] [717], [724], [706], [679], [726], [734], [683], [753], [698] [717], [724], [706], [679], [734], [683], [753], [698]
684	To generate fax call report, press 1 To clear fax call counts, press 2	[684]
685	To generate flash memory usage report, press 1. To clear flash memory usage report, press 2.	[685]
686	To generate mailbox usage report, press 1 To clear mailbox usage counts, press 2	[686]
687	To generate port usage report, press 1 To clear port usage counts, press 2	[687]

Table 82

Prompt No.	Modifiable Prompts	Linked to Prompt No. (s)
688	To generate system service report, press 1 For flash memory usage report management, press 2 For port usage report management, press 3 For mailbox usage report management, press 4 To generate mailbox parameter report, press 5 To generate call account report, press 6 To generate class of service parameter report, press 7 To generate fax call report, press 8	[688]
689	To go directly to a question, press 4	[627], [748], [749], [689] [644], [748], [749], [689] [681], [748], [749], [689] [748], [749], [689]
690	To hold this call, press 2	[268], [711], [690] [268], [711], [690], [275]
691	To insert a beeper display command, press 8	[647], [603], [733], [608], [692], [740], [693], [691] [647], [603], [733], [608], [692], [693], [691]
692	To insert a pause, press 5	[647], [603], [733], [608], [692], [740], [693] [647], [603], [733], [608], [692], [740], [693], [691] [647], [603], [733], [608], [692], [693] [647], [603], [733], [608], [692], [693], [691]
693	To insert a wait for dial tone, press 7	[647], [603], [733], [608], [692], [740], [693] [647], [603], [733], [608], [692], [740], [693], [691] [647], [603], [733], [608], [692], [693] [647], [603], [733], [608], [692], [693], [691]
694	To keep, press 2	[659], [694] [658], [694]
695	To leave a message, press 1	[695] [695], [673]

Table 82

Prompt No.	Modifiable Prompts	Linked to Prompt No. (s)
696	To let the caller select prompt language, press 4	[759], [760], [761], [696], [605]
697	To make this message private, press 1	[697], [392]
698	To message scan, press 8	[717], [724], [706], [679], [726], [734], [683], [753], [698] [717], [724], [706], [679], [734], [683], [753], [698]
699	To modify message, press 5	[752], [745], [652], [742], [699], [670] [752], [745], [652], [742], [699], [868], [670]
700	To notify your party's beeper, press 4	[700]
701	To page your party, press 3	[701]
702	To pause and restart recording, press 2	[669], [702] [668], [702] [702] [521], [669], [702]
703	To play the entire message, press 3	[723], [706], [703]
704	To play the message, press 1 To check the previous message, press 1 twice To check the next message, press 2	[704]
705	To play the next caller ID number, press 2	[659], [705]
706	To play the next message, press 2	[717], [706], [679], [726], [753], [208] [717], [724], [706], [679], [726], [734], [683], [753], [698] [723], [706], [703] [717], [706], [679], [753], [208] [717], [724], [706], [679], [734], [683], [753], [698] [724], [706] [706]
707	To play the next schedule, press 2	[728], [707], [719], [709] [707], [719], [709]
708	To play the next, press 2	[659], [708]

Table 82

Prompt No.	Modifiable Prompts	Linked to Prompt No. (s)
709	To play the previous schedule, press 4	[728], [707], [719], [709] [707], [719], [709]
710	To reach the covering extension, press 2	[710]
711	To receive the message, press 1	[268], [711], [690] [268], [711], [690], [275] [711], [663], [648], [201], [210], [212], [670] [711], [663], [648], [201], [210], [670] [711], [663], [652], [649], [200], [212], [670]
712	To record a message for external delivery, press 1 To check external delivery message status, press 2 To set up mailing list, press 3	[712]
713	To record a message, press 1 To add new mailbox number, press 2 To review the mailing list, press 3	[713]
714	To record a new prompt, press 1	[714], [680], [757] [714], [680], [911]
715	To record the question, press 1 To set the answer length, press 2 To erase the question, press 3	[715]
716	To record, press 1 To erase, press 2	[716]
717	To repeat this message, press 1	[717], [725], [670] [717], [725], [734], [683], [670] [717], [706], [679], [726], [753], [208] [717], [724], [706], [679], [726], [734], [683], [753], [698] [717], [706], [679], [753], [208] [717], [724], [706], [679], [734], [683], [753], [698]
718	To repeat this name, press 3	[602], [213], [718], [671]
719	To repeat this schedule, press 3	[728], [707], [719], [709] [707], [719], [709]

Table 82

Prompt No.	Modifiable Prompts	Linked to Prompt No. (s)
720	To repeat, press 1	[720], [670] [720], [392]
721	To repeat, press 3	[647], [603], [721]
722	To replay the previous message information, press 1 To play the next message's information, press 2 To play the message, press 3	[722]
723	To replay the previous message, press 1	[723], [706], [703]
724	To replay the previous message, press 1 twice	[717], [724], [706], [679], [726], [734], [683], [753], [698] [717], [724], [706], [679], [734], [683], [753], [698] [724], [706] [724]
725	To reply, press 2	[717], [725], [670] [717], [725], [734], [683], [670]
726	To reply, press 4	[717], [706], [679], [726], [753], [208] [717], [724], [706], [679], [726], [734], [683], [753], [698]
727	To report all mailbox usage, press 2	[751], [727]
728	To reschedule, press 1	[728], [707], [719], [709]
729	To retrieve the call, press 2	[729]
730	To review the mailing list, press 4	[755], [610], [730] [755], [754], [610], [730]
731	To review this group, press 4	[626], [606], [656], [731]
732	To review, press 1	[732], [603], [678], [614], [677] [732], [601], [678], [677] [732], [603], [678]

Table 82

Prompt No.	Modifiable Prompts	Linked to Prompt No. (s)
733	To review, press 3	[611], [657], [733] [639], [603], [733] [647], [603], [733], [608], [692], [740], [693] [647], [603], [733], [608], [692], [740], [693], [691] [647], [603], [733], [608], [692], [693] [647], [603], [733], [608], [692], [693], [691] [612], [660], [733] [612], [660], [733], [604]
734	To rewind, press 5	[717], [725], [734], [683], [670] [717], [724], [706], [679], [726], [734], [683], [753], [698] [717], [724], [706], [679], [734], [683], [753], [698]
735	To select caller select mode, press 1 To select without message mode, press 2 To select before message recording mode, press 3 To select after message recording mode, press 4 To disable all entry modes, press 5 To accept, press 6	[735]
736	To send to 1 recipient, press 1 To send by mailing list, press 2	[736]
737	To set call transfer status, press 1 To set up covering extension, press 2 To set message reception mode, press 3 To set incomplete handling status, press 4	[737]
738	To set delivery time or make this message private, press 1	[738], [603]
739	To set delivery time, press 1 For immediate delivery, press 2	[739]
740	To set dial mode, press 6	[647], [603], [733], [608], [692], [740], [693] [647], [603], [733], [608], [692], [740], [693], [691]

Table 82

Prompt No.	Modifiable Prompts	Linked to Prompt No. (s)
741	To set leaving a message status, press 1 To set covering extension transfer status, press 2 To set intercom paging status, press 3 To set beeper access status, press 4 To set operator transfer status, press 5 To set returning to top menu automated attendant service status, press 6	[741]
742	To set the clock, press 4	[752], [745], [652], [742], [699], [670] [752], [745], [652], [742], [699], [868], [670]
743	To set the group distribution lists, press 4	[637], [636], [634], [743] [637], [636], [634], [743], [628] [637], [636], [634], [743], [628], [869]
744	To set up mailbox, press 1 To set class of service, press 2 To set the clock, press 3	[744]
745	To set up message waiting notification, press 2	[745] [752], [745], [652], [742], [699], [670] [752], [745], [652], [742], [699], [868], [670]
746	To skip setting the password, press the hash sign	[120], [746] [152], [746]
747	To skip setting the password, press the pound sign	[120], [747] [153], [747]
748	To skip to the next question, press 2	[627], [748], [749], [689] [644], [748], [749], [689] [681], [748], [749], [689] [748], [749], [689]
749	To skip to the previous question, press 3	[627], [748], [749], [689] [644], [748], [749], [689] [681], [748], [749], [689] [748], [749], [689]
750	To skip, press 2	[647], [750], [757] [647], [750] [647], [750], [911]

Table 82

Prompt No.	Modifiable Prompts	Linked to Prompt No. (s)
751	To specify the mailbox range, press 1	[751], [727] [751], [650]
752	To transfer General Delivery Mailbox messages, press 1	[752], [745], [652], [742], [699], [670] [752], [745], [652], [742], [699], [868], [670]
753	To transfer this message, press 7	[717], [706], [679], [726], [753], [208] [717], [724], [706], [679], [726], [734], [683], [753], [698] [717], [706], [679], [753], [208] [717], [724], [706], [679], [734], [683], [753], [698]
754	To transfer with comment, press 2	[755], [754], [610], [730]
755	To transfer, press 1	[755], [610], [730] [755], [754], [610], [730]
756	To try again, press ✕	[619], [645], [756] [505], [756]
757	To turn off the prompt, press 3	[647], [750], [757] [714], [680], [757]
758	To use for scheduling, press 1 To use continuously, press 2 To use not at all, press 3	[758]
759	To use the system prompt, press 1	[759], [760], [761], [604] [759], [760], [761], [696], [605]
760	To use user 1 prompt, press 2	[759], [760], [761], [604] [759], [760], [761], [696], [605]
761	To use user 2 prompt, press 3	[759], [760], [761], [604] [759], [760], [761], [696], [605]
762	TONE DIALING MODE	[762]
763	Total message time available per mailbox is (time)	[763], [332]
764	Transferred (number)	[764], [600]
765	Transferred 1 time	[765]
766	TUESDAY	[766]
767	TWELFTH	[767]
768	TWELVE	[768]

Table 82

Prompt No.	Modifiable Prompts	Linked to Prompt No. (s)
769	TWELVE [HOUR]	[769]
770	TWELVE [MINUTE]	[770]
771	TWENTY	[771]
772	TWENTY [HOUR]	[772]
773	TWENTY [MINUTE]	[773]
774	TWENTY EIGHT	[774]
775	TWENTY EIGHT [MINUTE]	[775]
776	TWENTY EIGHTH	[776]
777	TWENTY FIFTH	[777]
778	TWENTY FIRST	[778]
779	TWENTY FIVE	[779]
780	TWENTY FIVE [MINUTE]	[780]
781	TWENTY FOUR	[781]
782	TWENTY FOUR [HOUR]	[782]
783	TWENTY FOUR [MINUTE]	[783]
784	TWENTY FOURTH	[784]
785	TWENTY NINE	[785]
786	TWENTY NINE [MINUTE]	[786]
787	TWENTY NINTH	[787]
788	TWENTY ONE	[788]
789	TWENTY ONE [HOUR]	[789]
790	TWENTY ONE [MINUTE]	[790]
791	TWENTY SECOND	[791]
792	TWENTY SEVEN	[792]
793	TWENTY SEVEN [MINUTE]	[793]
794	TWENTY SEVENTH	[794]
795	TWENTY SIX	[795]
796	TWENTY SIX [MINUTE]	[796]
797	TWENTY SIXTH	[797]
798	TWENTY THIRD	[798]

Table 82

Prompt No.	Modifiable Prompts	Linked to Prompt No. (s)
799	TWENTY THREE	[799]
800	TWENTY THREE [HOUR]	[800]
801	TWENTY THREE [MINUTE]	[801]
802	TWENTY TWO	[802]
803	TWENTY TWO [HOUR]	[803]
804	TWENTY TWO [MINUTE]	[804]
805	TWENTYTH	[805]
806	TWO	[806]
807	TWO [HOUR]	[807]
808	TWO [MINUTE]	[808]
809	unsuccessful attempts to enter this mailbox	[544], [809]
810	Use call waiting on busy signal disabled	[810]
811	Use call waiting on busy signal enabled	[811]
812	Use the hash sign key as a wild card character	[137], [812]
813	Use the pound sign key as a wild card character	[137], [813]
814	Verification deleted	[814]
815	was erased	[157], [815], [24]
816	was sent on (date)	[305], [816], [17]
817	WEDNESDAY	[817]
818	Welcome to the general delivery mailbox	[818]
819	Welcome to the Voice Processing System	[250], [819] [248], [819] [249], [819] [819]
820	When you are finished hang up, stay on the line to confirm or change your number	[411], [822], [82], [820]

Table 82

Prompt No.	Modifiable Prompts	Linked to Prompt No. (s)
821	You can add up to (number)	[821], [335] [821], [334]
822	You can enter up to (number)	[865], [822], [82] [411], [822], [82] [411], [822], [82], [820] [121], [822], [82] [875], [822], [82]
823	You can not add any more digits	[823]
824	You have (number)	[824], [340] [824], [330] [824], [164]
825	You have a call	[825]
826	You have a call from (name)	[826]
827	You have 1 FAX message	[827]
828	You have 1 message	[828]
829	You have 1 new message	[829]
830	ZERO	[830]
831	Break mode first operator's extension is (extension number)	[831]
832	Break mode first operator's extension is not assigned	[832]
833	Break mode second operator's extension is (extension number)	[833]
834	Break mode second operator's extension is not assigned	[834]
835	Break mode third operator's extension is (extension number)	[835]
836	Break mode third operator's extension is not assigned	[836]
837	Lunch mode first operator's extension is (extension number)	[837]
838	Lunch mode first operator's extension is not assigned	[838]

Table 82

Prompt No.	Modifiable Prompts	Linked to Prompt No. (s)
839	Lunch mode second operator's extension is (extension number)	[839]
840	Lunch mode second operator's extension is not assigned	[840]
841	Lunch mode third operator's extension is (extension number)	[841]
842	Lunch mode third operator's extension is not assigned	[842]
843	To change the company greeting, press 1 To change the company name, press 2 To change the department dialing menu, press 3 To change the custom service menu, press 4 To change the voice label, press 5 To modify the user prompt, press 6 To change the selection menu, press 7 To change the system caller name announcement, press 8	[843]
844	Enter a class of service number from 1 to 62	[844]
845	THOUSAND	[845]
846	Enter a message length from 1 to 6 minutes or 0 for unlimited length	[846]
847	Enter the total message time available per mailbox Valid entries are from 5 to 100 minutes or 0 for unlimited time	[847]
848	To set station call forwarding, press 4	[848]
849	To forward all calls, press 1	[849], [850], [851], [852], [853], [854] [849], [850], [851], [852], [854]
850	To forward busy calls, press 2	[849], [850], [851], [852], [853], [854] [849], [850], [851], [852], [854]
851	To forward no answer calls, press 3	[849], [850], [851], [852], [853], [854] [849], [850], [851], [852], [854]

Table 82

Prompt No.	Modifiable Prompts	Linked to Prompt No. (s)
852	To forward busy or no answer calls, press 4	[849], [850], [851], [852], [853], [854] [849], [850], [851], [852], [854]
853	To forward to a CO line, press 5	[849], [850], [851], [852], [853], [854]
854	To cancel call forwarding, press 6	[849], [850], [851], [852], [853], [854] [849], [850], [851], [852], [854]
855	Enter the destination extension number for forwarding	[855]
856	Your extension is call forwarded all calls to extension (extension number)	[856]
857	Your extension is call forwarded busy calls to extension (extension number)	[857]
858	Your extension is call forwarded no answer calls to extension (extension number)	[858]
859	Your extension is call forwarded busy or no answer calls to extension (extension number)	[859]
860	Call forwarding accepted	[860]
861	Call forwarding not accepted Please check the destination number	[861]
862	To forward to your Telephone number 1, press 1	[862]
863	To forward to your Telephone number 2, press 2	[863]
864	To forward to the other number, press 3	[864]
865	Enter the destination telephone number for forwarding	[865], [822], [82]
866	Your extension is call forwarded to telephone number (telephone number)	[866]
867	Call forwarding is cancelled	[867]
868	To set station call forwarding, press 6	[752], [745], [652], [742], [699], [868], [670]
869	To change Remote Call Forwarding to CO setting, press 6	[637], [636], [634], [743], [628], [869]

Table 82

Prompt No.	Modifiable Prompts	Linked to Prompt No. (s)
870	To change Telephone number 1, press 1 To change Telephone number 2, press 2	[870]
871	Telephone number 1 is not assigned	[871]
872	Telephone number 1 is (telephone number)	[872]
873	Telephone number 2 is not assigned	[873]
874	Telephone number 2 is (telephone number)	[874]
875	Enter the telephone number	[875], [822], [82]
876	Telephone number 1 for Remote Call Forward to CO is not assigned	[876]
877	Telephone number 1 for Remote Call Forward to CO is (telephone number)	[877]
878	Telephone number 2 for Remote Call Forward to CO is not assigned	[878]
879	Telephone number 2 for Remote Call Forward to CO is (telephone number)	[879]
880	Message length is unlimited	[880]
881	Total message time available per mailbox is unlimited	[881]
882	Remote Call Forward to CO disabled	[882]
883	Remote Call Forward to CO enabled	[883]
884	Delete message confirmation disabled	[884]
885	Delete message confirmation enabled	[885]
886	To set up mailbox, press 1 To set class of service, press 2 To set the clock, press 3 To change service mode setting, press 4 To change company greeting setting, press 5	[886]

Table 82

Prompt No.	Modifiable Prompts	Linked to Prompt No. (s)
887	To set up mailbox, press 1 To set class of service, press 2 To set the clock, press 3 To change service mode setting, press 4	[887]
888	For port setting, press 1 For trunk setting, press 2	[888]
889	Enter the port number	[889], [890]
890	from 1 to (number)	[889], [890] [892], [890]
891	Port number is (number)	[891]
892	Enter the trunk group number	[892], [890]
893	Trunk group number is (number)	[893]
894	For Day time, press 1 For Night time, press 2 For Lunch time, press 3 For Break time, press 4	[894]
895	Current company greeting setting is number (number)	[895]
896	Current company greeting setting is System Greeting	[896]
897	Current company greeting setting is disabled	[897]
898	To change company greeting number, press 1 To set system greeting, press 2 To disable, press 3	[898]
899	If you really want to erase, press 1 If not, press 2	[899]
900	To set Automatic mode, press 1 To set Manual Day mode, press 2 To set Manual Night mode, press 3 To set Manual Lunch mode, press 4 To set Manual Break mode, press 5 To set PBX Control mode, press 6	[900]
901	Current service mode is Automatic mode	[901]

Table 82

Prompt No.	Modifiable Prompts	Linked to Prompt No. (s)
902	Current service mode is Manual Day mode	[902]
903	Current service mode is Manual Night mode	[903]
904	Current service mode is Manual Lunch mode	[904]
905	Current service mode is Manual Break mode	[905]
906	Current service mode is PBX Control mode	[906]
907	To change, press 2	[612], [907], [661], [908]
908	To review, press 4	[612], [907], [661], [908]
909	To change caller ID number, press 1 To change caller name, press 2 To accept, press 3	[909]
910	All caller ID numbers deleted	[910]
911	To turn on the prompt, press 3	[647], [750], [911] [714], [680], [911]
912	The prompt is now turned on	[912]
913	Enter a message retention time up to 30 days or 0 for unlimited days	[913]
914	Enter a group number from 1 to 17	[914]

[Linked Prompts List]**Subscriber Service****Table 83**

[824] You have (number)	[544] There were (number of failure)
[338] new message	[809] unsuccessful attempts to enter this mailbox

Receive Message**Table 84**

[317] Message recorded by (mailbox number)	[325] Message transferred via (mailbox number)
[13] and transferred via (mailbox number)	[12] and (mailbox number)
[12] and (mailbox number)	
[318] Message recorded on (date)	[824] You have (number)
[17] at (time)	[330] Messages

Message Scan**Table 85**

[305] Message from (name)	
[816] was sent on (date)	
[17] at (time)	

Message Delivery**Table 86**

[594] This message will be delivered on (day)	
[17] at (time)	

Personal Group Distribution List**Table 87**

[821] You can add up to (number)	
[335] more members	

Check Mailbox Distribution**Table 88**

[304] Message for (name)	[323] Message sent on (date)
[432] received on (date)	[17] at (time)
[17] at (time)	[197] for (mailbox number)
[197] for (mailbox number)	[258] has been erased, because message retention time expired
[259] has not been received	

External Message Delivery

Table 89

[158] External delivery message scheduled for (name)	[592] This message is from (name)
[379] on (date)	[377] of (company name)
[17] at (time)	[157] External delivery message for (name)
[161] External delivery message will be sent to (name)	[815] was erased
[447] right away	[24] because message retention time expired
[324] Message to (name)	[272] I'll redial (number)
[31] being delivered now	[337] more times

Message Waiting Notification

Table 90

[411] Please enter your callback number	[411] Please enter your callback number
[822] You can enter up to (number) digits	[822] You can enter up to (number) digits
	[82] digits
	[820] When you are finished hang up, stay on the line to confirm or change your number
[575] This call is for (name)	
[247] from (name)	

Interview Mailbox Management

Table 91

[14] Answer length is (number)	
[454] seconds	

Fax Management

Table 92

[824] You have (number)	[764] Transferred (number)
[164] FAX messages	[600] times

Glossary

Alternate Extension Group

Transfers the call coming into the extensions in this group following the sequence specified by "Alternate Extension Transfer Sequence".

APT Integration

Digital Integration between the KX-TA624 and the VPS.

Auto Configuration

(Available with APT/DPT Integration only.) The VPS can automatically draw information from the KX-TA624, the KX-TD816, the KX-TD1232, the KX-TA1232, or the KX-TD308. This information includes, among other things, extension number assignments for each VPS port. This saves time in the initial setup. Auto Configuration can be executed by DIP Switch settings or by System Administration (Quick Setup).

Auto Forwarding

Allows unretrieved messages to be copied or moved to another mailbox.

Automated Attendant

The Automated Attendant feature of the VPS requests the caller to enter an extension number and then the VPS dials the number. If there is no answer or the line is busy, the caller is given some options, including the option to leave a message in a mailbox. This is the advantage of calling an extension indirectly through the Automated Attendant rather than calling it directly.

Call Blocking

Connects the caller to the Incomplete Call Handling Service without ringing the subscriber's extension.

Call Screening

Allows subscribers to screen calls. The VPS prompts the caller with the message "Record your name at the tone", and records the caller's name; it then puts the caller on hold while playing the name to the subscriber who decides whether to take the call or not.

Call Transfer

Transfers a call to the requested destination.

Called Party ID

(Sometimes referred to as Follow-On ID) Allows the PBX to dial extra digits to bring the caller directly to a specified mailbox, rather than to the General Delivery Mailbox.

Caller ID Call Routing

(Available with APT/DPT Integration only.) The VPS automatically sends calls from pre-assigned Caller ID numbers to the desired extension, mailbox (including System Group Distribution List) or Custom Service.

Caller Name Announcement (System/Personal)

(Available with APT/DPT Integration only.) The VPS announces prerecorded Caller ID callers' names when: (1) extension users listen to messages from pre-assigned numbers left in the users' mailboxes, (2) the VPS transfers calls from pre-assigned numbers to the users (Caller ID Screening), and (3) the VPS pages the users by intercom (Intercom Paging). If the same Caller ID number is programmed for both system and personal caller name announcements, the VPS will use the personal caller name.

Covering Extension

This can be a destination for Incomplete Call Handling Service. This can also be accessed by pressing [0] while a Personal Greeting is being played, or while a caller is leaving a message.

Custom Service Setting

Allows one-touch access to extensions, other custom service menus, fax machine, mailboxes, etc. A greeting can be recorded for each of the 100 menus to give verbal directions to the non-subscribers.

Default Setting

A parameter defined for the system at the factory which can be changed through system programming by the System Administrator or the System Manager.

Delayed Ringing

There are 2 kinds of delayed ringing applications:

- (1) The VPS is used as the no-answer destination for the Intercept Routing feature of your PBX.
- (2) DIL 1:N (CO line to several extensions) terminates on telephones and VPS ports. To give the telephone users a chance to answer calls, the VPS lines should be programmed for delayed ringing. Otherwise, the VPS will answer the calls immediately.

Delete Message Confirmation

The VPS requests confirmation from the mailbox owner before erasing a message left in the mailbox.

Delivery Time

The time specified by the subscriber for the VPS to deliver a prerecorded message. You can specify delivery time in External Delivery Message or when delivering a message to other subscribers (Subscriber's Guide Section 3.1)

Department Dialing

A speed-dialing feature that permits an outside caller to dial a single digit (1-9) to reach a specific extension.

Direct Mailbox Access

(Available with APT/DPT Integration only.) A subscriber can enter his mailbox directly when he calls the VPS from his extension. He does not have to enter any special codes except for his password, if one is established.

DPT Integration

Digital integration between the VPS and the KX-TD816, the KX-TD1232, the KX-TA1232, or the KX-TD308. Requires upgraded software in the PBX.

Depending on the model and/or the software version of the connected PBX, you may not be able to utilize some of the features available only with DPT Integration. For more information, call National Parts Center at 1-800-833-9626.

DTMF

(Dual Tone Multi Frequency) Commonly referred to as touchtone.

External Call Forwarding

(Available on the KX-TD816, the KX-TD1232, the KX-TA1232, and the KX-TD308.)

Forwards calls to an extension that has call forwarding activated to an outside phone.

External Delivery Message

A message intended for automatic delivery to outside parties and/or extensions.

The message can be delivered immediately or at a specified time.

External Message Delivery List

Allows the subscriber to create 2 lists to deliver messages to outside parties. Each list can have 8 destinations.

External Message Delivery Redial

Allows the System Administrator to instruct the VPS when making external message deliveries how many attempts to make when the line is busy or when there is no answer.

Fast Forward

Puts the user 4 s ahead in the current message.

Follow-On ID

See Called Party ID.

General Delivery Mailbox

When the caller does not dial anything (either because he does not want to or he is using a rotary telephone), the VPS sends him to the General Delivery Mailbox.

Periodically (daily is best), the Message Manager should transfer the contents of the General Delivery Mailbox to the appropriate destinations.

Hash Sign

Same as Pound Sign.

HELP

One of the utility commands that is used to list all utility commands with a brief description of each.

Immediate Reply

Allows the message receiver to reply to a message without specifying the extension number or the mailbox number of the sender.

Inband Signaling

The Follow-On ID (or Called Party ID) that integrates the VPS and the PBX. Uses intercom paths to light message wait light. Does not give "high end" features such as: Intercom Paging, Direct Mailbox Access, Live Call Screening, etc.

Incomplete Call Handling Service

Calls are considered incomplete when there is no answer or if the line is busy.

There are 6 options for the Incomplete Call Handling Service:

- (1) to record a message from the caller,
- (2) transfer the caller to a covering extension,
- (3) page the mailbox owner via the PBX,
- (4) notify the mailbox owner via beeper,
- (5) transfer the caller to the operator, or
- (6) let the caller try another extension.

Integration

Required between the VPS and the PBX. See Inband Signaling, APT Integration and DPT Integration.

Intercept Routing No Answer

Transfers an unanswered call to another extension or to the VPS.
(This is a PBX feature.)

Intercom Paging

(Available with APT/DPT Integration only.) Allows up to 8 different paging groups. An outside party can reach a subscriber who is away from her telephone using either internal or external page groups. For a Caller ID caller, if her name has been recorded for the Caller Name Announcement feature, the name will be announced at the end of the page.

Interview Service

A special type of subscriber mailbox that enables the subscriber to record up to 10 questions. After the answers are recorded, the Message Waiting Lamp turns on at the subscriber's telephone. (Good for claims departments, order desks, job applications, etc.)

Keypad

All touchtone keys on the telephone.

LCD

Liquid crystal display

Live Call Screening

(Available with APT/DPT Integration only.) The proprietary telephone works like an answering machine. The subscriber can hear the caller through the speakerphone or the handset while the message is being recorded.

LOAD

One of the utility commands that is used to load new or saved data to the VPS from a personal computer.

Logical Extension (All Calls Transfer to Mailbox)

An extension that always receives calls directly into its mailbox. This feature is used by subscribers who are often unavailable or who do not have a telephone.

Mailbox Capacity (messages)

The number of messages that can be recorded in a subscriber's mailbox: should be set between 5 and 100 messages by the System Administrator or the System Manager.

Mailbox Capacity (recording time)

The total length of time for messages in a subscriber's mailbox: should be set between 5 and 100 min or unlimited length by the System Administrator or the System Manager.

Mailbox Extension

Normally the same number as the telephone extension number.

Mailbox Management

Allows a subscriber to alter the setting for personal mailboxes.

Menu

A list of choices from which the user can select by using the telephone keypad or the keys from a personal computer.

Message Manager

(Mailbox 98, 998, 9998, or 99998) The person who takes care of the General Delivery Mailbox and records: the Department Dialing Menu, Custom Service Menus, Voice Labels, User Prompts (User 1/User 2), Multilingual Selection Menu, and System Caller Names.

Message Retention Time

New Message Retention Time—the length of time the VPS will store a new (unplayed) message before deleting the message.

Saved Message Retention Time—the length of time the VPS will store an old (played) message before deleting the message.

Message Retrieval Order

The order in which the subscriber retrieves messages: Last In First Out (LIFO) or First In First Out (FIFO).

Message Transfer

Allows a subscriber to reroute a message to another mailbox unless the message was marked "private". Additional comments can be added to this message.

Message Waiting Lamp

Light on proprietary telephones that lights when there are messages in the mailbox.

Message Waiting Notification

The VPS can notify subscribers and the Message Manager when they have received messages (if authorized by the System Administrator or the System Manager). There are 3 notification methods: (1) by the Message Waiting Lamp, (2) by a telephone, or (3) by a beeper.

Multilingual Selection Menu

The Message Manager is responsible for recording this menu. Allows callers to choose the language they want (System, User 1 or User 2 prompts) when they call the VPS.

Non-Subscriber

A caller to the VPS who does not own a mailbox.

Notification Method

(See Message Waiting Notification.)

Operator

Up to three destinations can be assigned as operators. This is the extension that receives calls when the calling party is on a rotary phone or dials [0].

Owner's Name

After a subscriber records his name, the VPS announces his name during transfers, Intercom Paging, and confirmation of Dialing by Name.

Independent of this recording is registration of name by System Administrator. This allows callers to dial parties by name (Dialing by Name) rather than by number. For example, a caller can dial "S-M-I-T" (Smith) rather than Smith's mailbox number, which can be hard to remember.

Password

A combination of numbers selected by the subscriber to protect access to his mailbox. If forgotten, the System Administrator or System Manager can clear it so that the subscriber can select a new password.

Personal Greetings

A subscriber can record messages to greet callers. There are 3 kinds of Personal Greetings:

- (1) No Answer Greeting
- (2) Busy Signal Greeting
- (3) After Hours Greeting

Personal Greeting for Caller ID

(Available with APT/DPT Integration only.) A subscriber can record up to 4 personal greeting messages for calls from pre-assigned Caller ID numbers. Each greeting supports up to 8 Caller ID numbers.

Personal Group Distribution List

A subscriber can maintain up to 4 distribution lists, each containing a maximum of 20 mailboxes. Using this list, he can send the same message to all members of a specific distribution list at once.

Port

The point of connection between the PBX and the VPS.

Pound Sign

The [#] key on the telephone keypad.

Private Message

A message recorded as a private message cannot be forwarded. You can specify privacy when delivering a message to other subscribers (Subscriber's Guide Section 3.1).

Prompt

Prerecorded VPS sentences that guide subscribers and non-subscribers through specific VPS functions. The VPS supports 3 prompts: (1) System prompts (prerecorded at the factory in English), (2) User 1 prompts*, and (3) User 2 prompts*.

Prompts are numbered; the Message Manager can turn off and on the prompts individually.

*: freely recorded by the Message Manager

Remote Call Forward to CO

(Available with DPT Integration only.) Allows the System Administrator to program Telephone number 1 and Telephone number 2 as the destination to which the callers are forwarded when the Remote Call Forwarding is set to an outside (CO) line. This feature must be enabled in the COS (Class of Service) setting to be utilized. See Remote Call Forwarding Set.

Remote Call Forwarding Set

(Available with DPT Integration only.) A subscriber and the Message Manager can program his extension from a remote location to forward various types of calls to a desired extension or an outside telephone. There are 6 forwarding settings available:

- (1) Forward All Calls
- (2) Forward Busy Calls
- (3) Forward No Answer Calls
- (4) Forward Busy or No Answer Calls
- (5) Forward to a CO Line
- (6) Forward Cancel.

See Remote Call Forward to CO.

Review

Plays back a message.

Rewind

Replays the last 4 s of a message.

Rotary Telephone

A telephone capable of pulse dial only. Callers using a rotary telephone will be automatically forwarded to the operator or the General Delivery Mailbox.

SAVE

One of the utility commands that is used to save VPS data to a personal computer.

Scanning Messages

Allows the subscriber to listen to only the first 4 s of each message. Another method is to press [2] while listening to a message; this instructs the VPS to skip to the next message.

Service Mode

The System Administrator or the System Manager can change the call handling method programmed in the Time Service setting.

Station Programming

Programming via the proprietary telephone.

Subscriber

A person who has an assigned mailbox.

System Administration

System programming can be performed via 2 ways: (1) Locally (personal computer connected directly to the RS-232C port of the VPS), or (2) remotely (personal computer connected via the telephone network and the external modem of the VPS).

Note: Local programming and remote programming are mutually exclusive.

System Administrator

Unlike the Message Manager and the System Manager, who use a telephone to perform their duties, the System Administrator uses a personal computer to program the VPS. The System Administrator's handbook is the Installation Manual.

System External Message Delivery Duration Time

The maximum time allowed for an external message that is to be delivered by the VPS, specified by the System Administrator.

System Group Distribution List

The VPS can maintain up to 20 distribution lists, each containing a maximum of 20 mailboxes. Each list is referenced by a System Group Distribution List number and is assigned via system administration. A recording into a System Group Distribution List number will go into the mailboxes of all group members.

System Manager

(Mailbox 99, 999, 9999, or 99999) The person who can perform very basic and limited system programming using a telephone. He can create/delete mailboxes, clear subscriber passwords when they are forgotten, set Class of Service parameters, set the System Clock, and generate System Reports.

System Report

The System Administrator or System Manager can generate 8 System Reports to monitor the VPS operating status as required.

TIME

One of the utility commands that is used to confirm or set the time and date of the VPS.

Time Synchronization

(Available with DPT Integration only.) When the PBX sets a new date and time or when DPT Integration is established, the data is sent from the PBX to the VPS.

Two-Way Recording

(Available with APT/DPT Integration only.) Allows a subscriber to record a conversation into his mailbox.

Two-Way Transfer

(Available with APT/DPT Integration only.) Allows a subscriber to record a conversation into another person's mailbox.

Unlimited Message Length

Permits a mailbox owner to record two-way conversations of unlimited length into his or another person's mailbox (Two-Way Recording or Two-Way Transfer). The maximum recording time for other messages will automatically be set to 6 min.

Voice Mail

A general term used for messages recorded over the phone from one person to another.

Voice Prompt

Recorded VPS instructions to callers. These are either system prompts or user prompts.

VPS

Voice Processing System (e.g., Panasonic KX-TVS50).

INDEX

A

Alternate extension group 174
APT integration 20, 65, 174
Auto configuration 175
Auto forwarding 175
Automated attendant 175

B

Broadcasting messages 175
Busy coverage mode 176

C

Call services 176
Call Transfer No Answer Time 113, 259
Call transfer status 176
Callback number entry 177
Callback Telephone Number 262
Caller ID call routing 177
Caller ID screening 177
Caller name announcement—personal 178
Caller name announcement—system 178
Calling a beeper 179
Class of service (COS) 180
Connections—PBX 35
Covering extension 180
Custom service 180

D

Data—loading new or saved data to the VPS
(LOAD) 148
Data—saving the system data to the backup device
(SAVE) 134, 146
Daylight saving time assignment 180
Delete message confirmation 181
Department dialing 181
Dialing by name 181
Digital integration 20, 23, 65
DIP switch 18, 31, 73, 76, 84
Direct mailbox access 181
DPT integration 20, 65, 182

E

Extension group 182
Extension numbering plan 182
External message delivery list 182
External message delivery service 183
External message delivery status 183

F

Fax management 184

G

Group distribution list—personal 184
Group distribution list—system 184

H

Hardware settings 46, 269
Hold 184
Holiday service 185

I

Inband Integration 185
Incomplete call handling service 185
Initializing the system 138
Intercom paging 186
Interview service 187

L

Live Call Screening 188
LOAD 148
Logical extension 189

M

Mailbox 189
Message delivery status 190
Message delivery, internal 189
Message management 16, 130
Message manager's guide 303
Message reception mode 190
Message scan 190
Message transfer 191
Message waiting notification—device 191
Message waiting notification—lamp 192
Multilingual service 192

N

No answer coverage mode 193

O

Operator service 193

P

Password administration 193
PBX Integration 193
Personal greeting for Caller ID 194
Personal greetings 194
Play system prompt after personal greeting 195
Port service 195
Private message 195

Q

Quick setup 96, 97, 154

R

Receive message 195
Remote Call Forwarding Set 196, 319
Rotary telephone service 197

RS-232C parameters 269

S

SAVE 134, 146

Service access commands 197

Service mode 197, 293

Special feature authorization 198

Specifications—outline 21

Specifications—VPS 171

Subscriber service prompt selection 218

System administration 16

System administrator's guide 203

System clock 198, 291

System components 17

System management 16

System manager's guide 279

System reports 198

T

Time service 199

Time synchronization 199

Troubleshooting 167

Trunk service 199

Twenty-four-hour time stamp 255

Two-Way Recording 199

Two-Way Transfer 200

U

Unlimited message length 200

Utility commands 200

V

Voice mail service 200

Voice prompts 201

**Panasonic Consumer Electronics
Company, Division of Matsushita
Electric Corporation of America**
One Panasonic Way, Secaucus,
New Jersey 07094
www.panasonic.com

**Panasonic Sales Company (“PSC”)
Division of Matsushita Electric of
Puerto Rico, Inc.**
Ave. 65 de Infantería, Km. 9.5,
San Gabriel Industrial Park, Carolina,
Puerto Rico 00985

Copyright:

This manual is copyrighted by Kyushu Matsushita Electric Co., Ltd. (KME). You may print out this manual solely for internal use with this model. Except above, you may not reproduce this manual in any form, in whole or part, without the prior written consent of KME and its licensee.

© 2002 Kyushu Matsushita Electric Co., Ltd. All Rights Reserved.

Printed in Japan

PSQX2838ZA KK0802YK0