

Chapter 6

WIND LOADS

6.1 GENERAL

6.1.1 Scope. Buildings and other structures, including the Main Wind-Force Resisting System (MWFRS) and all components and cladding thereof, shall be designed and constructed to resist wind loads as specified herein.

6.1.2 Allowed Procedures. The design wind loads for buildings and other structures, including the MWFRS and component and cladding elements thereof, shall be determined using one of the following procedures: (1) Method 1—Simplified Procedure as specified in Section 6.4 for buildings meeting the requirements specified therein; (2) Method 2—Analytical Procedure as specified in Section 6.5 for buildings meeting the requirements specified therein; (3) Method 3—Wind Tunnel Procedure as specified in Section 6.6.

6.1.3 Wind Pressures Acting on Opposite Faces of Each Building Surface. In the calculation of design wind loads for the MWFRS and for components and cladding for buildings, the algebraic sum of the pressures acting on opposite faces of each building surface shall be taken into account.

6.1.4 Minimum Design Wind Loading. The design wind load, determined by any one of the procedures specified in Section 6.1.2, shall be not less than specified in this section.

6.1.4.1 Main Wind-Force Resisting System. The wind load to be used in the design of the MWFRS for an enclosed or partially enclosed building or other structure shall not be less than 10 lb/ft^2 (0.48 kN/m^2) multiplied by the area of the building or structure projected onto a vertical plane normal to the assumed wind direction. The design wind force for open buildings and other structures shall be not less than 10 lb/ft^2 (0.48 kN/m^2) multiplied by the area A_f .

6.1.4.2 Components and Cladding. The design wind pressure for components and cladding of buildings shall not be less than a net pressure of 10 lb/ft^2 (0.48 kN/m^2) acting in either direction normal to the surface.

6.2 DEFINITIONS

The following definitions apply only to the provisions of Chapter 6:

APPROVED: Acceptable to the authority having jurisdiction.

BASIC WIND SPEED, V : Three-second gust speed at 33 ft (10 m) above the ground in Exposure C (see Section 6.5.6.3) as determined in accordance with Section 6.5.4.

BUILDING, ENCLOSED: A building that does not comply with the requirements for open or partially enclosed buildings.

BUILDING ENVELOPE: Cladding, roofing, exterior walls, glazing, door assemblies, window assemblies, skylight assemblies, and other components enclosing the building.

BUILDING AND OTHER STRUCTURE, FLEXIBLE: Slender buildings and other structures that have a fundamental natural frequency less than 1 Hz.

BUILDING, LOW-RISE: Enclosed or partially enclosed buildings that comply with the following conditions:

1. Mean roof height h less than or equal to 60 ft (18 m).
2. Mean roof height h does not exceed least horizontal dimension.

BUILDING, OPEN: A building having each wall at least 80 percent open. This condition is expressed for each wall by the equation $A_o \geq 0.8A_g$ where

A_o = total area of openings in a wall that receives positive external pressure, in ft^2 (m^2)

A_g = the gross area of that wall in which A_o is identified, in ft^2 (m^2)

BUILDING, PARTIALLY ENCLOSED: A building that complies with both of the following conditions:

1. The total area of openings in a wall that receives positive external pressure exceeds the sum of the areas of openings in the balance of the building envelope (walls and roof) by more than 10 percent.
2. The total area of openings in a wall that receives positive external pressure exceeds 4 ft^2 (0.37 m^2) or 1 percent of the area of that wall, whichever is smaller, and the percentage of openings in the balance of the building envelope does not exceed 20 percent.

These conditions are expressed by the following equations:

1. $A_o > 1.10A_{oi}$
2. $A_o > 4 \text{ sq ft}$ (0.37 m^2) or $> 0.01A_g$, whichever is smaller, and $A_{oi}/A_{gi} \leq 0.20$

where

A_o, A_g are as defined for Open Building

A_{oi} = the sum of the areas of openings in the building envelope (walls and roof) not including A_o , in ft^2 (m^2)

A_{gi} = the sum of the gross surface areas of the building envelope (walls and roof) not including A_g , in ft^2 (m^2)

BUILDING OR OTHER STRUCTURE, REGULAR-SHAPED: A building or other structure having no unusual geometrical irregularity in spatial form.

BUILDING OR OTHER STRUCTURES, RIGID: A building or other structure whose fundamental frequency is greater than or equal to 1 Hz.

BUILDING, SIMPLE DIAPHRAGM: A building in which both windward and leeward wind loads are transmitted through floor and roof diaphragms to the same vertical MWFRS (e.g., no structural separations).

COMPONENTS AND CLADDING: Elements of the building envelope that do not qualify as part of the MWFRS.

DESIGN FORCE, F : Equivalent static force to be used in the determination of wind loads for open buildings and other structures.

DESIGN PRESSURE, p : Equivalent static pressure to be used in the determination of wind loads for buildings.

EAVE HEIGHT, h : The distance from the ground surface adjacent to the building to the roof eave line at a particular wall. If the height of the eave varies along the wall, the average height shall be used.

EFFECTIVE WIND AREA, A : The area used to determine GC_p . For component and cladding elements, the effective wind area in Figs. 6-11 through 6-17 and Fig. 6-19 is the span length multiplied by an effective width that need not be less than one-third the span length. For cladding fasteners, the effective wind area shall not be greater than the area that is tributary to an individual fastener.

ESCARPMENT: Also known as scarp, with respect to topographic effects in Section 6.5.7, a cliff or steep slope generally separating two levels or gently sloping areas (see Fig. 6-4).

FREE ROOF: Roof with a configuration generally conforming to those shown in Figs. 6-18A through 6-18D (monoslope, pitched, or troughed) in an open building with no enclosing walls underneath the roof surface.

GLAZING: Glass or transparent or translucent plastic sheet used in windows, doors, skylights, or curtain walls.

GLAZING, IMPACT RESISTANT: Glazing that has been shown by testing in accordance with ASTM E1886 and ASTM E1996 or other approved test methods to withstand the impact of wind-borne missiles likely to be generated in wind-borne debris regions during design winds.

HILL: With respect to topographic effects in Section 6.5.7, a land surface characterized by strong relief in any horizontal direction (see Fig. 6-4).

HURRICANE PRONE REGIONS: Areas vulnerable to hurricanes; in the United States and its territories defined as

1. The U.S. Atlantic Ocean and Gulf of Mexico coasts where the basic wind speed is greater than 90 mi/h, and
2. Hawaii, Puerto Rico, Guam, Virgin Islands, and American Samoa.

IMPACT RESISTANT COVERING: A covering designed to protect glazing, which has been shown by testing in accordance with ASTM E1886 and ASTM E1996 or other approved test methods to withstand the impact of wind-borne debris missiles likely to be generated in wind-borne debris regions during design winds.

IMPORTANCE FACTOR, I : A factor that accounts for the degree of hazard to human life and damage to property.

MAIN WIND-FORCE RESISTING SYSTEM (MWFRS): An assemblage of structural elements assigned to provide support and stability for the overall structure. The system generally receives wind loading from more than one surface.

MEAN ROOF HEIGHT, h : The average of the roof eave height and the height to the highest point on the roof surface, except that, for roof angles of less than or equal to 10° , the mean roof height shall be the roof heave height.

OPENINGS: Apertures or holes in the building envelope that allow air to flow through the building envelope and that are designed as "open" during design winds as defined by these provisions.

RECOGNIZED LITERATURE: Published research findings and technical papers that are approved.

RIDGE: With respect to topographic effects in Section 6.5.7 an elongated crest of a hill characterized by strong relief in two directions (see Fig. 6-4).

WIND-BORNE DEBRIS REGIONS: Areas within hurricane prone regions located:

1. Within 1 mile of the coastal mean high water line where the basic wind speed is equal to or greater than 110 mi/h and in Hawaii, or
2. In areas where the basic wind speed is equal to or greater than 120 mi/h.

6.3 SYMBOLS AND NOTATION

The following symbols and notation apply only to the provisions of Chapter 6:

A = effective wind area, in ft^2 (m^2)

A_f = area of open buildings and other structures either normal to the wind direction or projected on a plane normal to the wind direction, in ft^2 (m^2)

A_g = the gross area of that wall in which A_o is identified, in ft^2 (m^2)

A_{gi} = the sum of the gross surface areas of the building envelope (walls and roof) not including A_g , in ft^2 (m^2)

A_o = total area of openings in a wall that receives positive external pressure, in ft^2 (m^2)

A_{oi} = the sum of the areas of openings in the building envelope (walls and roof) not including A_o , in ft^2 (m^2)

A_{og} = total area of openings in the building envelope in ft^2 (m^2)

A_s = gross area of the solid freestanding wall or solid sign, in ft^2 (m^2)

a = width of pressure coefficient zone, in ft (m)

B = horizontal dimension of building measured normal to wind direction, in ft (m)

\bar{b} = mean hourly wind speed factor in Eq. 6-14 from Table 6-2

\hat{b} = 3-s gust speed factor from Table 6-2

C_f = force coefficient to be used in determination of wind loads for other structures

C_N = net pressure coefficient to be used in determination of wind loads for open buildings

C_p = external pressure coefficient to be used in determination of wind loads for buildings

c = turbulence intensity factor in Eq. 6-5 from Table 6-2

D = diameter of a circular structure or member, in ft (m)

D' = depth of protruding elements such as ribs and spoilers, in ft (m)

F = design wind force for other structures, in lb (N)

G = gust effect factor

G_f = gust effect factor for MWFRSs of flexible buildings and other structures

GC_{pn} = combined net pressure coefficient for a parapet

GC_p = product of external pressure coefficient and gust-effect factor to be used in determination of wind loads for buildings

- GC_{pf} = product of the equivalent external pressure coefficient and gust-effect factor to be used in determination of wind loads for MWFRS of low-rise buildings
- GC_{pi} = product of internal pressure coefficient and gust-effect factor to be used in determination of wind loads for buildings
- g_Q = peak factor for background response in Eqs. 6-4 and 6-8
- g_R = peak factor for resonant response in Eq. 6-8
- g_v = peak factor for wind response in Eqs. 6-4 and 6-8
- H = height of hill or escarpment in Fig. 6-4, in ft (m)
- h = mean roof height of a building or height of other structure, except that eave height shall be used for roof angle θ of less than or equal to 10° , in ft (m)
- h_e = roof eave height at a particular wall, or the average height if the eave varies along the wall
- I = importance factor
- I_z = intensity of turbulence from Eq. 6-5
- K_1, K_2, K_3 = multipliers in Fig. 6-4 to obtain K_{zt}
- K_d = wind directionality factor in Table 6-4
- K_h = velocity pressure exposure coefficient evaluated at height $z = h$
- K_z = velocity pressure exposure coefficient evaluated at height z
- K_{zt} = topographic factor as defined in Section 6.5.7
- L = horizontal dimension of a building measured parallel to the wind direction, in ft (m)
- L_h = distance upwind of crest of hill or escarpment in Fig. 6-4 to where the difference in ground elevation is half the height of hill or escarpment, in ft (m)
- $L_{\bar{z}}$ = integral length scale of turbulence, in ft (m)
- L_r = horizontal dimension of return corner for a solid freestanding wall or solid sign from Fig. 6-20, in ft (m)
- ℓ = integral length scale factor from Table 6-2, ft (m)
- N_1 = reduced frequency from Eq. 6-12
- n_1 = building natural frequency, Hz
- p = design pressure to be used in determination of wind loads for buildings, in lb/ft² (N/m²)
- p_L = wind pressure acting on leeward face in Fig. 6-9, in lb/ft² (N/m²)
- p_{net} = net design wind pressure from Eq. 6-2, in lb/ft² (N/m²)
- p_{net30} = net design wind pressure for Exposure B at $h = 30$ ft and $I = 1.0$ from Fig. 6-3, in lb/ft² (N/m²)
- p_p = combined net pressure on a parapet from Eq. 6-20, in lb/ft² (N/m²)
- p_s = net design wind pressure from Eq. 6-1, in lb/ft² (N/m²)
- p_{s30} = simplified design wind pressure for Exposure B at $h = 30$ ft and $I = 1.0$ from Fig. 6-2, in lb/ft² (N/m²)
- p_W = wind pressure acting on windward face in Fig. 6-9, in lb/ft² (N/m²)
- Q = background response factor from Eq. 6-6
- q = velocity pressure, in lb/ft² (N/m²)
- q_h = velocity pressure evaluated at height $z = h$, in lb/ft² (N/m²)
- q_i = velocity pressure for internal pressure determination, in lb/ft² (N/m²)
- q_p = velocity pressure at top of parapet, in lb/ft² (N/m²)
- q_z = velocity pressure evaluated at height z above ground, in lb/ft² (N/m²)
- R = resonant response factor from Eq. 6-10
- R_B, R_h, R_L = values from Eq. 6-13
- R_i = reduction factor from Eq. 6-16
- R_n = value from Eq. 6-11
- s = vertical dimension of the solid freestanding wall or solid sign from Fig. 6-20, in ft (m)
- r = rise-to-span ratio for arched roofs
- V = basic wind speed obtained from Fig. 6-1, in mi/h (m/s). The basic wind speed corresponds to a 3-s gust speed at 33 ft (10 m) above ground in exposure Category C
- V_i = unpartitioned internal volume ft³ (m³)
- \bar{V}_z = mean hourly wind speed at height \bar{z} , ft/s (m/s)
- W = width of building in Figs. 6-12 and 6-14A and B and width of span in Figs. 6-13 and 6-15, in ft (m)
- X = distance to center of pressure from windward edge in Fig. 6-18, in ft (m)
- x = distance upwind or downwind of crest in Fig. 6-4, in ft (m)
- z = height above ground level, in ft (m)
- \bar{z} = equivalent height of structure, in ft (m)
- z_g = nominal height of the atmospheric boundary layer used in this standard. Values appear in Table 6-2
- z_{min} = exposure constant from Table 6-2
- α = 3-s gust-speed power law exponent from Table 6-2
- $\hat{\alpha}$ = reciprocal of α from Table 6-2
- $\bar{\alpha}$ = mean hourly wind-speed power law exponent in Eq. 6-14 from Table 6-2
- β = damping ratio, percent critical for buildings or other structures
- ϵ = ratio of solid area to gross area for solid freestanding wall, solid sign, open sign, face of a trussed tower, or lattice structure
- λ = adjustment factor for building height and exposure from Figs. 6-2 and 6-3
- $\bar{\epsilon}$ = integral length scale power law exponent in Eq. 6-7 from Table 6-2
- η = value used in Eq. 6-13 (see Section 6.5.8.2)
- θ = angle of plane of roof from horizontal, in degrees
- v = height-to-width ratio for solid sign

6.4 METHOD 1—SIMPLIFIED PROCEDURE

6.4.1 Scope. A building whose design wind loads are determined in accordance with this section shall meet all the conditions of

6.4.1.1 or 6.4.1.2. If a building qualifies only under 6.4.1.2 for design of its components and cladding, then its MWFRS shall be designed by Method 2 or Method 3.

6.4.1.1 Main Wind-Force Resisting Systems. For the design of MWFRSs the building must meet all of the following conditions:

1. The building is a simple diaphragm building as defined in Section 6.2.
2. The building is a low-rise building as defined in Section 6.2.
3. The building is enclosed as defined in Section 6.2 and conforms to the wind-borne debris provisions of Section 6.5.9.3.
4. The building is a regular-shaped building or structure as defined in Section 6.2.
5. The building is not classified as a flexible building as defined in Section 6.2.
6. The building does not have response characteristics making it subject to across wind loading, vortex shedding, instability due to galloping or flutter; and does not have a site location for which channeling effects or buffeting in the wake of upwind obstructions warrant special consideration.
7. The building has an approximately symmetrical cross-section in each direction with either a flat roof or a gable or hip roof with $\theta \leq 45^\circ$.
8. The building is exempted from torsional load cases as indicated in Note 5 of Fig. 6-10, or the torsional load cases defined in Note 5 do not control the design of any of the MWFRSs of the building.

6.4.1.2 Components and Cladding. For the design of components and cladding the building must meet all the following conditions:

1. The mean roof height h must be less than or equal to 60 ft ($h \leq 60$ ft).
2. The building is enclosed as defined in Section 6.2 and conforms to the wind-borne debris provisions of Section 6.5.9.3.
3. The building is a regular-shaped building or structure as defined in Section 6.2.
4. The building does not have response characteristics making it subject to across wind loading, vortex shedding, instability due to galloping or flutter; and does not have a site location for which channeling effects or buffeting in the wake of upwind obstructions warrant special consideration.
5. The building has either a flat roof, a gable roof with $\theta \leq 45^\circ$, or a hip roof with $\theta \leq 27^\circ$.

6.4.2 Design Procedure.

1. The *basic wind speed* V shall be determined in accordance with Section 6.5.4. The wind shall be assumed to come from any horizontal direction.
2. An *importance factor* I shall be determined in accordance with Section 6.5.5.
3. An *exposure category* shall be determined in accordance with Section 6.5.6.
4. A height and exposure adjustment coefficient, λ , shall be determined from Fig. 6-2.

6.4.2.1 Main Wind-Force Resisting System. Simplified design wind pressures, p_s , for the MWFRSs of low-rise simple diaphragm buildings represent the net pressures (sum of internal and external) to be applied to the horizontal and vertical projections

of building surfaces as shown in Fig. 6-2. For the horizontal pressures (zones A, B, C, D), p_s is the combination of the windward and leeward net pressures. p_s shall be determined by the following equation:

$$p_s = \lambda K_{zt} I p_{S30} \quad (6-1)$$

where

λ = adjustment factor for building height and exposure from Fig. 6-2

K_{zt} = topographic factor as defined in Section 6.5.7 evaluated at mean roof height, h

I = importance factor as defined in Section 6.2

p_{S30} = simplified design wind pressure for Exposure B, at $h = 30$ ft, and for $I = 1.0$, from Fig. 6-2

6.4.2.1.1 Minimum Pressures. The load effects of the design wind pressures from Section 6.4.2.1 shall not be less than the minimum load case from Section 6.1.4.1 assuming the pressures, p_s , for zones A, B, C, and D all equal to +10 psf, while assuming zones E, F, G, and H all equal to 0 psf.

6.4.2.2 Components and Cladding. Net design wind pressures, p_{net} , for the components and cladding of buildings designed using Method 1 represent the net pressures (sum of internal and external) to be applied normal to each building surface as shown in Fig. 6-3. p_{net} shall be determined by the following equation:

$$p_{net} = \lambda K_{zt} I p_{net30} \quad (6-2)$$

where

λ = adjustment factor for building height and exposure from Fig. 6-3

K_{zt} = topographic factor as defined in Section 6.5.7 evaluated at mean roof height, h

I = importance factor as defined in Section 6.2

p_{net30} = net design wind pressure for exposure B, at $h = 30$ ft, and for $I = 1.0$, from Fig. 6-3

6.4.2.2.1 Minimum Pressures. The positive design wind pressures, p_{net} , from Section 6.4.2.2 shall not be less than +10 psf, and the negative design wind pressures, p_{net} , from Section 6.4.2.2 shall not be less than -10 psf.

6.4.3 Air Permeable Cladding. Design wind loads determined from Fig. 6.3 shall be used for all air permeable cladding unless approved test data or the recognized literature demonstrate lower loads for the type of air permeable cladding being considered.

6.5 METHOD 2—ANALYTICAL PROCEDURE

6.5.1 Scope. A building or other structure whose design wind loads are determined in accordance with this section shall meet all of the following conditions:

1. The building or other structure is a regular-shaped building or structure as defined in Section 6.2.
2. The building or other structure does not have response characteristics making it subject to across wind loading, vortex shedding, instability due to galloping or flutter; or does not have a site location for which channeling effects or buffeting in the wake of upwind obstructions warrant special consideration.

6.5.2 Limitations. The provisions of Section 6.5 take into consideration the load magnification effect caused by gusts in resonance with along-wind vibrations of flexible buildings or other structures. Buildings or other structures not meeting the requirements of Section 6.5.1, or having unusual shapes or response

characteristics, shall be designed using recognized literature documenting such wind load effects or shall use the wind tunnel procedure specified in Section 6.6.

6.5.2.1 Shielding. There shall be no reductions in velocity pressure due to apparent shielding afforded by buildings and other structures or terrain features.

6.5.2.2 Air Permeable Cladding. Design wind loads determined from Section 6.5 shall be used for air permeable cladding unless approved test data or recognized literature demonstrate lower loads for the type of air permeable cladding being considered.

6.5.3 Design Procedure.

1. The *basic wind speed* V and *wind directionality factor* K_d shall be determined in accordance with Section 6.5.4.
2. An *importance factor* I shall be determined in accordance with Section 6.5.5.
3. An *exposure category* or *exposure categories* and *velocity pressure exposure coefficient* K_z or K_h , as applicable, shall be determined for each wind direction in accordance with Section 6.5.6.
4. A *topographic factor* K_{zt} shall be determined in accordance with Section 6.5.7.
5. A *gust effect factor* G or G_f , as applicable, shall be determined in accordance with Section 6.5.8.
6. An *enclosure classification* shall be determined in accordance with Section 6.5.9.
7. *Internal pressure coefficient* GC_{pi} shall be determined in accordance with Section 6.5.11.1.
8. *External pressure coefficients* C_p or GC_{pf} , or *force coefficients* C_f , as applicable, shall be determined in accordance with Section 6.5.11.2 or 6.5.11.3, respectively.
9. *Velocity pressure* q_z or q_h , as applicable, shall be determined in accordance with Section 6.5.10.
10. *Design wind load* p or F shall be determined in accordance with Sections 6.5.12, 6.5.13, 6.5.14, and 6.5.15, as applicable.

6.5.4 Basic Wind Speed. The basic wind speed, V , used in the determination of design wind loads on buildings and other structures shall be as given in Fig. 6-1 except as provided in Sections 6.5.4.1 and 6.5.4.2. The wind shall be assumed to come from any horizontal direction.

6.5.4.1 Special Wind Regions. The basic wind speed shall be increased where records or experience indicate that the wind speeds are higher than those reflected in Fig. 6-1. Mountainous terrain, gorges, and special regions shown in Fig. 6-1 shall be examined for unusual wind conditions. The authority having jurisdiction shall, if necessary, adjust the values given in Fig. 6-1 to account for higher local wind speeds. Such adjustment shall be based on meteorological information and an estimate of the basic wind speed obtained in accordance with the provisions of Section 6.5.4.2.

6.5.4.2 Estimation of Basic Wind Speeds from Regional Climatic Data. In areas outside hurricane-prone regions, regional climatic data shall only be used in lieu of the basic wind speeds given in Fig. 6-1 when (1) approved extreme-value statistical-analysis procedures have been employed in reducing the data; and (2) the length of record, sampling error, averaging time, anemometer height, data quality, and terrain exposure of

the anemometer have been taken into account. Reduction in basic wind speed below that of Fig. 6-1 shall be permitted.

In hurricane-prone regions, wind speeds derived from simulation techniques shall only be used in lieu of the basic wind speeds given in Fig. 6-1 when (1) approved simulation and extreme value statistical analysis procedures are used (the use of regional wind speed data obtained from anemometers is not permitted to define the hurricane wind-speed risk along the Gulf and Atlantic coasts, the Caribbean, or Hawaii) and (2) the design wind speeds resulting from the study shall not be less than the resulting 500-year return period wind speed divided by $\sqrt{1.5}$.

In areas outside hurricane-prone regions, when the basic wind speed is estimated from regional climatic data, the basic wind speed shall be not less than the wind speed associated with an annual probability of 0.02 (50-year mean recurrence interval), and the estimate shall be adjusted for equivalence to a 3-s gust wind speed at 33 ft (10 m) above ground in exposure Category C. The data analysis shall be performed in accordance with this chapter.

6.5.4.3 Limitation. Tornadoes have not been considered in developing the basic wind-speed distributions.

6.5.4.4 Wind Directionality Factor. The wind directionality factor, K_d , shall be determined from Table 6-4. This factor shall only be applied when used in conjunction with load combinations specified in Sections 2.3 and 2.4.

6.5.5 Importance Factor. An importance factor, I , for the building or other structure shall be determined from Table 6-1 based on building and structure categories listed in Table 1-1.

6.5.6 Exposure. For each wind direction considered, the upwind exposure category shall be based on ground surface roughness that is determined from natural topography, vegetation, and constructed facilities.

6.5.6.1 Wind Directions and Sectors. For each selected wind direction at which the wind loads are to be evaluated, the exposure of the building or structure shall be determined for the two upwind sectors extending 45° either side of the selected wind direction. The exposures in these two sectors shall be determined in accordance with Sections 6.5.6.2 and 6.5.6.3 and the exposure resulting in the highest wind loads shall be used to represent the winds from that direction.

6.5.6.2 Surface Roughness Categories. A ground surface roughness within each 45° sector shall be determined for a distance upwind of the site as defined in Section 6.5.6.3 from the categories defined in the following text, for the purpose of assigning an exposure category as defined in Section 6.5.6.3.

Surface Roughness B: Urban and suburban areas, wooded areas, or other terrain with numerous closely spaced obstructions having the size of single-family dwellings or larger.

Surface Roughness C: Open terrain with scattered obstructions having heights generally less than 30 ft (9.1 m). This category includes flat open country, grasslands, and all water surfaces in hurricane prone regions.

Surface Roughness D: Flat, unobstructed areas and water surfaces outside hurricane prone regions. This category includes smooth mud flats, salt flats, and unbroken ice.

6.5.6.3 Exposure Categories

Exposure B: Exposure B shall apply where the ground surface roughness condition, as defined by Surface Roughness B, prevails in the upwind direction for a distance of at least 2,600 ft (792 m) or 20 times the height of the building, whichever is greater.

EXCEPTION: For buildings whose mean roof height is less than or equal to 30 ft, the upwind distance may be reduced to 1,500 ft (457 m).

Exposure C: Exposure C shall apply for all cases where Exposures B or D do not apply.

Exposure D: Exposure D shall apply where the ground surface roughness, as defined by Surface Roughness D, prevails in the upwind direction for a distance greater than 5,000 ft (1,524 m) or 20 times the building height, whichever is greater. Exposure D shall extend into downwind areas of Surface Roughness B or C for a distance of 600 ft (200 m) or 20 times the height of the building, whichever is greater.

For a site located in the transition zone between exposure categories, the category resulting in the largest wind forces shall be used.

EXCEPTION: An intermediate exposure between the preceding categories is permitted in a transition zone provided that it is determined by a rational analysis method defined in the recognized literature.

6.5.6.4 Exposure Category for Main Wind-Force Resisting System.

6.5.6.4.1 Buildings and Other Structures. For each wind direction considered, wind loads for the design of the MWFRS determined from Fig. 6-6 shall be based on the exposure categories defined in Section 6.5.6.3.

6.5.6.4.2 Low-Rise Buildings. Wind loads for the design of the MWFRSs for low-rise buildings shall be determined using a velocity pressure q_h based on the exposure resulting in the highest wind loads for any wind direction at the site where external pressure coefficients GC_{pf} given in Fig. 6-10 are used.

6.5.6.5 Exposure Category for Components and Cladding. Components and cladding design pressures for all buildings and other structures shall be based on the exposure resulting in the highest wind loads for any direction at the site.

6.5.6.6 Velocity Pressure Exposure Coefficient. Based on the exposure category determined in Section 6.5.6.3, a velocity pressure exposure coefficient K_z or K_h , as applicable, shall be determined from Table 6-3. For a site located in a transition zone between exposure categories, that is, near to a change in ground surface roughness, intermediate values of K_z or K_h , between those shown in Table 6-3, are permitted, provided that they are determined by a rational analysis method defined in the recognized literature.

6.5.7 Topographic Effects.

6.5.7.1 Wind Speed-Up over Hills, Ridges, and Escarpments. Wind speed-up effects at isolated hills, ridges, and escarpments constituting abrupt changes in the general topography, located in any exposure category, shall be included in the design when buildings and other site conditions and locations of structures meet all of the following conditions:

1. The hill, ridge, or escarpment is isolated and unobstructed upwind by other similar topographic features of comparable height for 100 times the height of the topographic feature ($100H$) or 2 mi (3.22 km), whichever is less. This distance shall be measured horizontally from the point at which the height H of the hill, ridge, or escarpment is determined.
2. The hill, ridge, or escarpment protrudes above the height of upwind terrain features within a 2-mi (3.22 km) radius in any quadrant by a factor of two or more.
3. The structure is located as shown in Fig. 6-4 in the upper one-half of a hill or ridge or near the crest of an escarpment.

$$4. H/L_h \geq 0.2.$$

5. H is greater than or equal to 15 ft (4.5 m) for Exposures C and D and 60 ft (18 m) for Exposure B.

6.5.7.2 Topographic Factor. The wind speed-up effect shall be included in the calculation of design wind loads by using the factor K_{zt} :

$$K_{zt} = (1 + K_1 K_2 K_3)^2 \quad (6-3)$$

where K_1 , K_2 , and K_3 are given in Fig. 6-4.

If site conditions and locations of structures do not meet all the conditions specified in Section 6.5.7.1 then $K_{zt} = 1.0$.

6.5.8 Gust Effect Factor.

6.5.8.1 Rigid Structures. For rigid structures as defined in Section 6.2, the gust-effect factor shall be taken as 0.85 or calculated by the formula:

$$G = 0.925 \left(\frac{(1 + 1.7g_Q I_{\bar{z}} Q)}{1 + 1.7g_v I_{\bar{z}}} \right) \quad (6-4)$$

$$I_{\bar{z}} = c \left(\frac{33}{\bar{z}} \right)^{1/6} \quad (6-5)$$

$$\text{In SI: } I_{\bar{z}} = c \left(\frac{10}{\bar{z}} \right)^{1/6}$$

where $I_{\bar{z}}$ = the intensity of turbulence at height \bar{z} where \bar{z} = the equivalent height of the structure defined as $0.6h$, but not less than z_{\min} for all building heights h . z_{\min} and c are listed for each exposure in Table 6-2; g_Q and g_v shall be taken as 3.4. The background response Q is given by

$$Q = \sqrt{\frac{1}{1 + 0.63 \left(\frac{B + h}{L_{\bar{z}}} \right)^{0.63}}} \quad (6-6)$$

where B , h are defined in Section 6.3; and $L_{\bar{z}}$ = the integral length scale of turbulence at the equivalent height given by

$$L_{\bar{z}} = \ell \left(\frac{\bar{z}}{33} \right)^{\bar{\epsilon}} \quad (6-7)$$

$$\text{In SI: } L_{\bar{z}} = \ell \left(\frac{\bar{z}}{10} \right)^{\bar{\epsilon}}$$

in which ℓ and $\bar{\epsilon}$ are constants listed in Table 6-2.

6.5.8.2 Flexible or Dynamically Sensitive Structures. For flexible or dynamically sensitive structures as defined in Section 6.2, the gust-effect factor shall be calculated by

$$G_f = 0.925 \left(\frac{1 + 1.7I_{\bar{z}} \sqrt{g_Q^2 Q^2 + g_R^2 R^2}}{1 + 1.7g_v I_{\bar{z}}} \right) \quad (6-8)$$

g_Q and g_v shall be taken as 3.4 and g_R is given by

$$g_R = \sqrt{2 \ln(3,600n_1)} + \frac{0.577}{\sqrt{2 \ln(3,600n_1)}} \quad (6-9)$$

R , the resonant response factor, is given by

$$R = \sqrt{\frac{1}{\beta} R_n R_h R_B (0.53 + 0.47R_L)} \quad (6-10)$$

$$R_n = \frac{7.47N_1}{(1 + 10.3N_1)^{5/3}} \quad (6-11)$$

$$N_1 = \frac{n_1 L \bar{V}_z}{\bar{V}_z} \quad (6-12)$$

$$R_\ell = \frac{1}{\eta} - \frac{1}{2\eta^2} (1 - e^{-2\eta}) \quad \text{for } \eta > 0 \quad (6-13a)$$

$$R_\ell = 1 \quad \text{for } \eta = 0 \quad (6-13b)$$

where the subscript ℓ in Eq. 6-13 shall be taken as h , B , and L , respectively, where h , B , and L are defined in Section 6.3.

n_1 = building natural frequency

$R_\ell = R_h$ setting $\eta = 4.6n_1 h / \bar{V}_z$

$R_\ell = R_B$ setting $\eta = 4.6n_1 E B / \bar{V}_z$

$R_\ell = R_L$ setting $\eta = 15.4n_1 L / \bar{V}_z$

β = damping ratio, percent of critical

\bar{V}_z = mean hourly wind speed (ft/s) at height \bar{z} determined from Eq. 6-14.

$$\bar{V}_z = \bar{b} \left(\frac{\bar{z}}{33} \right)^{\bar{\alpha}} V \left(\frac{88}{60} \right) \quad (6-14)$$

In SI: $\bar{V}_z = \bar{b} \left(\frac{\bar{z}}{10} \right)^{\bar{\alpha}} V$

where \bar{b} and $\bar{\alpha}$ are constants listed in Table 6-2 and V is the basic wind speed in mi/h.

6.5.8.3 Rational Analysis. In lieu of the procedure defined in Sections 6.5.8.1 and 6.5.8.2, determination of the gust-effect factor by any rational analysis defined in the recognized literature is permitted.

6.5.8.4 Limitations. Where combined gust-effect factors and pressure coefficients (GC_p , GC_{pi} , and GC_{pf}) are given in figures and tables, the gust-effect factor shall not be determined separately.

6.5.9 Enclosure Classifications.

6.5.9.1 General. For the purpose of determining internal pressure coefficients, all buildings shall be classified as enclosed, partially enclosed, or open as defined in Section 6.2.

6.5.9.2 Openings. A determination shall be made of the amount of openings in the building envelope to determine the enclosure classification as defined in Section 6.5.9.1.

6.5.9.3 Wind-Borne Debris. Glazing in buildings located in wind-borne debris regions shall be protected with an impact-resistant covering or be impact-resistant glazing according to the requirements specified in ASTM E1886 and ASTM E1996 or other approved test methods and performance criteria. The levels of impact resistance shall be a function of Missile Levels and Wind Zones specified in ASTM E1886 and ASTM E1996.

EXCEPTIONS:

1. Glazing in Category II, III, or IV buildings located over 60 ft (18.3 m) above the ground and over 30 ft (9.2 m) above aggregate surface roofs located within 1,500 ft (458 m) of the building shall be permitted to be unprotected.
2. Glazing in Category I buildings shall be permitted to be unprotected.

6.5.9.4 Multiple Classifications. If a building by definition complies with both the “open” and “partially enclosed” definitions, it shall be classified as an “open” building. A building that does not comply with either the “open” or “partially enclosed” definitions shall be classified as an “enclosed” building.

6.5.10 Velocity Pressure. Velocity pressure, q_z , evaluated at height z shall be calculated by the following equation:

$$q_z = 0.00256 K_z K_{zt} K_d V^2 I \quad (\text{lb/ft}^2) \quad (6-15)$$

[In SI: $q_z = 0.613 K_z K_{zt} K_d V^2 I$ (N/m²); V in m/s]

where K_d is the wind directionality factor defined in Section 6.5.4.4, K_z is the velocity pressure exposure coefficient defined in Section 6.5.6.6, K_{zt} is the topographic factor defined in Section 6.5.7.2, and q_h is the velocity pressure calculated using Eq. 6-15 at mean roof height h .

The numerical coefficient 0.00256 (0.613 in SI) shall be used except where sufficient climatic data are available to justify the selection of a different value of this factor for a design application.

6.5.11 Pressure and Force Coefficients.

6.5.11.1 Internal Pressure Coefficient. Internal pressure coefficients, GC_{pi} , shall be determined from Fig. 6-5 based on building enclosure classifications determined from Section 6.5.9.

6.5.11.1.1 Reduction Factor for Large Volume Buildings, R_i . For a partially enclosed building containing a single, unpartitioned large volume, the internal pressure coefficient, GC_{pi} , shall be multiplied by the following reduction factor, R_i :

$$R_i = 1.0 \quad \text{or}$$

$$R_i = 0.5 \left(1 + \frac{1}{\sqrt{1 + \frac{V_i}{22,800 A_{og}}}} \right) \leq 1.0 \quad (6-16)$$

where

A_{og} = total area of openings in the building envelope (walls and roof, in ft²)

V_i = unpartitioned internal volume, in ft³

6.5.11.2 External Pressure Coefficients.

6.5.11.2.1 Main Wind-Force Resisting Systems. External pressure coefficients for MWFRSs C_p are given in Figs. 6-6, 6-7, and 6-8. Combined gust effect factor and external pressure coefficients, GC_{pf} , are given in Fig. 6-10 for low-rise buildings. The pressure coefficient values and gust effect factor in Fig. 6-10 shall not be separated.

6.5.11.2.2 Components and Cladding. Combined gust-effect factor and external pressure coefficients for components and cladding GC_p are given in Figs. 6-11 through 6-17. The pressure coefficient values and gust-effect factor shall not be separated.

6.5.11.3 Force Coefficients. Force coefficients C_f are given in Figs. 6-20 through 6-23.

6.5.11.4 Roof Overhangs.

6.5.11.4.1 Main Wind-Force Resisting System. Roof overhangs shall be designed for a positive pressure on the bottom surface of windward roof overhangs corresponding to $C_p = 0.8$ in combination with the pressures determined from using Figs. 6-6 and 6-10.

6.5.11.4.2 Components and Cladding. For all buildings, roof overhangs shall be designed for pressures determined from pressure coefficients given in Figs. 6-11B,C,D.

6.5.11.5 Parapets.

6.5.11.5.1 Main Wind-Force Resisting System. The pressure coefficients for the effect of parapets on the MWFRS loads are given in Section 6.5.12.2.4

6.5.11.5.2 Components and Cladding. The pressure coefficients for the design of parapet component and cladding elements are taken from the wall and roof pressure coefficients as specified in Section 6.5.12.4.4.

6.5.12 Design Wind Loads on Enclosed and Partially Enclosed Buildings.

6.5.12.1 General.

6.5.12.1.1 Sign Convention. Positive pressure acts toward the surface and negative pressure acts away from the surface.

6.5.12.1.2 Critical Load Condition. Values of external and internal pressures shall be combined algebraically to determine the most critical load.

6.5.12.1.3 Tributary Areas Greater than 700 ft² (65 m²). Component and cladding elements with tributary areas greater than 700 ft² (65 m²) shall be permitted to be designed using the provisions for MWFRSs.

6.5.12.2 Main Wind-Force Resisting Systems.

6.5.12.2.1 Rigid Buildings of All Heights. Design wind pressures for the MWFRS of buildings of all heights shall be determined by the following equation:

$$p = qGC_p - q_i(GC_{pi}) \text{ (lb/ft}^2\text{) (N/m}^2\text{)} \quad (6-17)$$

where

$q = q_z$ for windward walls evaluated at height z above the ground

$q = q_h$ for leeward walls, side walls, and roofs, evaluated at height h

$q_i = q_h$ for windward walls, side walls, leeward walls, and roofs of enclosed buildings and for negative internal pressure evaluation in partially enclosed buildings

$q_i = q_z$ for positive internal pressure evaluation in partially enclosed buildings where height z is defined as the level of the highest opening in the building that could affect the positive internal pressure. For buildings sited in wind-borne debris regions, glazing that is not impact resistant or protected with an impact resistant covering, shall be treated as an opening in accordance with Section 6.5.9.3. For positive internal pressure evaluation, q_i may conservatively be evaluated at height h ($q_i = q_h$)

G = gust effect factor from Section 6.5.8

C_p = external pressure coefficient from Fig. 6-6 or 6-8

(GC_{pi}) = internal pressure coefficient from Fig. 6-5

q and q_i shall be evaluated using exposure defined in Section 6.5.6.3. Pressure shall be applied simultaneously on windward and leeward walls and on roof surfaces as defined in Figs. 6-6 and 6-8.

6.5.12.2.2 Low-Rise Building. Alternatively, design wind pressures for the MWFRS of low-rise buildings shall be determined by the following equation:

$$p = q_h[(GC_{pf}) - (GC_{pi})] \text{ (lb/ft}^2\text{) (N/m}^2\text{)} \quad (6-18)$$

where

q_h = velocity pressure evaluated at mean roof height h using exposure defined in Section 6.5.6.3

(GC_{pf}) = external pressure coefficient from Fig. 6-10

(GC_{pi}) = internal pressure coefficient from Fig. 6-5

6.5.12.2.3 Flexible Buildings. Design wind pressures for the MWFRS of flexible buildings shall be determined from the following equation:

$$p = qG_f C_p - q_i(GC_{pi}) \text{ (lb/ft}^2\text{) (N/m}^2\text{)} \quad (6-19)$$

where q , q_i , C_p , and (GC_{pi}) are as defined in Section 6.5.12.2.1 and G_f = gust effect factor is defined as in Section 6.5.8.2.

6.5.12.2.4 Parapets. The design wind pressure for the effect of parapets on MWFRSs of rigid, low-rise, or flexible buildings with flat, gable, or hip roofs shall be determined by the following equation:

$$p_p = q_p GC_{pn} \text{ (lb/ft}^2\text{)} \quad (6-20)$$

where

p_p = combined net pressure on the parapet due to the combination of the net pressures from the front and back parapet surfaces. Plus (and minus) signs signify net pressure acting toward (and away from) the front (exterior) side of the parapet

q_p = velocity pressure evaluated at the top of the parapet

GC_{pn} = combined net pressure coefficient

= +1.5 for windward parapet

= -1.0 for leeward parapet

6.5.12.3 Design Wind Load Cases. The MWFRS of buildings of all heights, whose wind loads have been determined under the provisions of Sections 6.5.12.2.1 and 6.5.12.2.3, shall be designed for the wind load cases as defined in Fig. 6-9. The eccentricity e for rigid structures shall be measured from the geometric center of the building face and shall be considered for each principal axis (e_x , e_y). The eccentricity e for flexible structures shall be determined from the following equation and shall be considered for each principal axis (e_x , e_y):

$$e = \frac{e_Q + 1.7I_z \sqrt{(g_Q Q e_Q)^2 + (g_R R e_R)^2}}{1 + 1.7I_z \sqrt{(g_Q Q)^2 + (g_R R)^2}} \quad (6-21)$$

where

e_Q = eccentricity e as determined for rigid structures in Fig. 6-9

e_R = distance between the elastic shear center and center of mass of each floor

I_z , g_Q , Q , g_R , R shall be as defined in Section 6.5.8

The sign of the eccentricity e shall be plus or minus, whichever causes the more severe load effect.

EXCEPTION: One-story buildings with h less than or equal to 30 ft, buildings two stories or less framed with light-frame construction, and buildings two stories or less designed with flexible diaphragms need only be designed for Load Case 1 and Load Case 3 in Fig. 6-9.

6.5.12.4 Components and Cladding.

6.5.12.4.1 Low-Rise Buildings and Buildings with $h \leq 60$ ft (18.3 m). Design wind pressures on component and cladding elements of low-rise buildings and buildings with $h \leq 60$ ft (18.3 m) shall be determined from the following equation:

$$p = q_h[(GC_p) - (GC_{pi})] \text{ (lb/ft}^2\text{) (N/m}^2\text{)} \quad (6-22)$$

where

q_h = velocity pressure evaluated at mean roof height h using exposure defined in Section 6.5.6.3

(GC_p) = external pressure coefficients given in Figs. 6-11 through 6-16

(GC_{pi}) = internal pressure coefficient given in Fig. 6-5

6.5.12.4.2 Buildings with $h > 60$ ft (18.3 m). Design wind pressures on components and cladding for all buildings with $h > 60$ ft (18.3 m) shall be determined from the following equation:

$$p = q(GC_p) - q_i(GC_{pi}) \text{ (lb/ft}^2\text{) (N/m}^2\text{)} \quad (6-23)$$

where

$q = q_z$ for windward walls calculated at height z above the ground

$q = q_h$ for leeward walls, side walls, and roofs, evaluated at height h

$q_i = q_h$ for windward walls, side walls, leeward walls, and roofs of enclosed buildings and for negative internal pressure evaluation in partially enclosed buildings

$q_i = q_z$ for positive internal pressure evaluation in partially enclosed buildings where height z is defined as the level of the highest opening in the building that could affect the positive internal pressure. For buildings sited in wind-borne debris regions, glazing that is not impact resistant or protected with an impact-resistant covering, shall be treated as an opening in accordance with Section 6.5.9.3. For positive internal pressure evaluation, q_i may conservatively be evaluated at height h ($q_i = q_h$)

(GC_p) = external pressure coefficient from Fig. 6-17

(GC_{pi}) = internal pressure coefficient given in Fig. 6-5.

q and q_i shall be evaluated using exposure defined in Section 6.5.6.3.

6.5.12.4.3 Alternative Design Wind Pressures for Components and Cladding in Buildings with 60 ft (18.3 m) $< h < 90$ ft (27.4 m). Alternative to the requirements of Section 6.5.12.4.2, the design of components and cladding for buildings with a mean roof height greater than 60 ft (18.3 m) and less than 90 ft (27.4 m) values from Figs. 6-11 through 6-17 shall be used only if the height to width ratio is one or less (except as permitted by Note 6 of Fig. 6-17) and Eq. 6-22 is used.

6.5.12.4.4 Parapets. The design wind pressure on the components and cladding elements of parapets shall be designed by the following equation:

$$p = q_p(GC_p - GC_{pi}) \quad (6-24)$$

where

q_p = velocity pressure evaluated at the top of the parapet

GC_p = external pressure coefficient from Figs. 6-11 through 6-17

GC_{pi} = internal pressure coefficient from Fig. 6-5, based on the porosity of the parapet envelope

Two load cases shall be considered. Load Case A shall consist of applying the applicable positive wall pressure from Fig. 6-11A or Fig. 6-17 to the front surface of the parapet while applying the applicable negative edge or corner zone roof pressure from Figs. 6-11 through 6-17 to the back surface. Load Case B shall consist of applying the applicable positive wall pressure from Fig. 6-11A or Fig. 6-17 to the back of the parapet surface, and applying the applicable negative wall pressure from Fig. 6-11A or Fig. 6-17 to the front surface. Edge and corner zones shall be arranged as shown in Figs. 6-11 through 6-17. GC_p shall be determined for appropriate roof angle and effective wind area from Figs. 6-11 through 6-17. If internal pressure is present, both load cases should be evaluated under positive and negative internal pressure.

6.5.13 Design Wind Loads on Open Buildings with Monoslope, Pitched, or Troughed Roofs.

6.5.13.1 General.

6.5.13.1.1 Sign Convention. Plus and minus signs signify pressure acting toward and away from the top surface of the roof, respectively.

6.5.13.1.2 Critical Load Condition. Net pressure coefficients C_N include contributions from top and bottom surfaces. All load cases shown for each roof angle shall be investigated.

6.5.13.2 Main Wind-Force Resisting Systems. The net design pressure for the MWFRSs of monoslope, pitched, or troughed roofs shall be determined by the following equation:

$$p = q_h GC_N \quad (6-25)$$

where

q_h = velocity pressure evaluated at mean roof height h using the exposure as defined in Section 6.5.6.3 that results in the highest wind loads for any wind direction at the site

G = gust effect factor from Section 6.5.8

C_N = net pressure coefficient determined from Figs. 6-18A through 6-18D

For free roofs with an angle of plane of roof from horizontal θ less than or equal to 5° and containing fascia panels, the fascia panel shall be considered an inverted parapet. The contribution of loads on the fascia to the MWFRS loads shall be determined using Section 6.5.12.2.4 with q_p equal to q_h .

6.5.13.3 Component and Cladding Elements. The net design wind pressure for component and cladding elements of monoslope, pitched, and troughed roofs shall be determined by the following equation:

$$p = q_h GC_N \quad (6-26)$$

where

q_h = velocity pressure evaluated at mean roof height h using the exposure as defined in Section 6.5.6.3 that results in the highest wind loads for any wind direction at the site

G = gust-effect factor from Section 6.5.8

C_N = net pressure coefficient determined from Figs. 6-19A through 6-19C

6.5.14 Design Wind Loads on Solid Freestanding Walls and Solid Signs. The design wind force for solid freestanding walls and solid signs shall be determined by the following formula:

$$F = q_h GC_f A_s \text{ (lb) (N)} \quad (6-27)$$

where

q_h = the velocity pressure evaluated at height h (defined in Fig. 6-20) using exposure defined in Section 6.5.6.4.1

G = gust-effect factor from Section 6.5.8

C_f = net force coefficient from Fig. 6-20

A_s = the gross area of the solid freestanding wall or solid sign, in ft^2 (m^2)

6.5.15 Design Wind Loads on Other Structures. The design wind force for other structures shall be determined by the following equation:

$$F = q_z GC_f A_f \text{ (lb) (N)} \quad (6-28)$$

where

q_z = velocity pressure evaluated at height z of the centroid of area A_f using exposure defined in Section 6.5.6.3

G = gust-effect factor from Section 6.5.8

C_f = force coefficients from Figs. 6-21 through 6-23

A_f = projected area normal to the wind except where C_f is specified for the actual surface area, ft^2 (m^2)

6.5.15.1 Rooftop Structures and Equipment for Buildings with $h \leq 60$ ft (18.3 m). The force on rooftop structures and equipment with A_f less than $(0.1Bh)$ located on buildings with $h \leq 60$ ft (18.3 m) shall be determined from Eq. 6-28, increased by a factor of 1.9. The factor shall be permitted to be reduced linearly from 1.9 to 1.0 as the value of A_f is increased from $(0.1Bh)$ to (Bh) .

6.6 METHOD 3—WIND TUNNEL PROCEDURE

6.6.1 Scope. Wind tunnel tests shall be used where required by Section 6.5.2. Wind tunnel testing shall be permitted in lieu of Methods 1 and 2 for any building or structure.

6.6.2 Test Conditions. Wind tunnel tests, or similar tests employing fluids other than air, used for the determination of design wind loads for any building or other structure, shall be conducted in accordance with this section. Tests for the determination of mean and fluctuating forces and pressures shall meet all of the following conditions:

1. The natural atmospheric boundary layer has been modeled to account for the variation of wind speed with height.
2. The relevant macro- (integral) length and micro-length scales of the longitudinal component of atmospheric turbulence are modeled to approximately the same scale as that used to model the building or structure.
3. The modeled building or other structure and surrounding structures and topography are geometrically similar to their full-scale counterparts, except that, for low-rise buildings meeting the requirements of Section 6.5.1, tests shall be permitted for the modeled building in a single exposure site as defined in Section 6.5.6.3.
4. The projected area of the modeled building or other structure and surroundings is less than 8 percent of the test section cross-sectional area unless correction is made for blockage.
5. The longitudinal pressure gradient in the wind tunnel test section is accounted for.
6. Reynolds number effects on pressures and forces are minimized.

7. Response characteristics of the wind tunnel instrumentation are consistent with the required measurements.

6.6.3 Dynamic Response. Tests for the purpose of determining the dynamic response of a building or other structure shall be in accordance with Section 6.6.2. The structural model and associated analysis shall account for mass distribution, stiffness, and damping.

6.6.4 Limitations.

6.6.4.1 Limitations on Wind Speeds. Variation of basic wind speeds with direction shall not be permitted unless the analysis for wind speeds conforms to the requirements of Section 6.5.4.2.

6.6.5 Wind-Borne Debris. Glazing in buildings in wind-borne debris regions shall be protected in accordance with Section 6.5.9.3.

6.7 CONSENSUS STANDARDS AND OTHER REFERENCED DOCUMENTS

This section lists the consensus standards and other documents which are adopted by reference within this chapter:

ASTM
ASTM International
100 Barr Harbor Drive
West Conshohocken, PA 19428-2959

ASTM E1886
Section 6.5.9.3
Standard Test Method for Performance of Exterior Windows, Curtain Walls, Doors and Storm Shutters Impacted by Missile(s) and Exposed to Cyclic Pressure Differentials, 2002.

ASTM E1996
Section 6.5.9.3
Standard Specification for Performance of Exterior Windows, Curtain Walls, Doors and Storm Shutters Impacted by Windborne Debris in Hurricanes, 2003.

This page intentionally left blank.

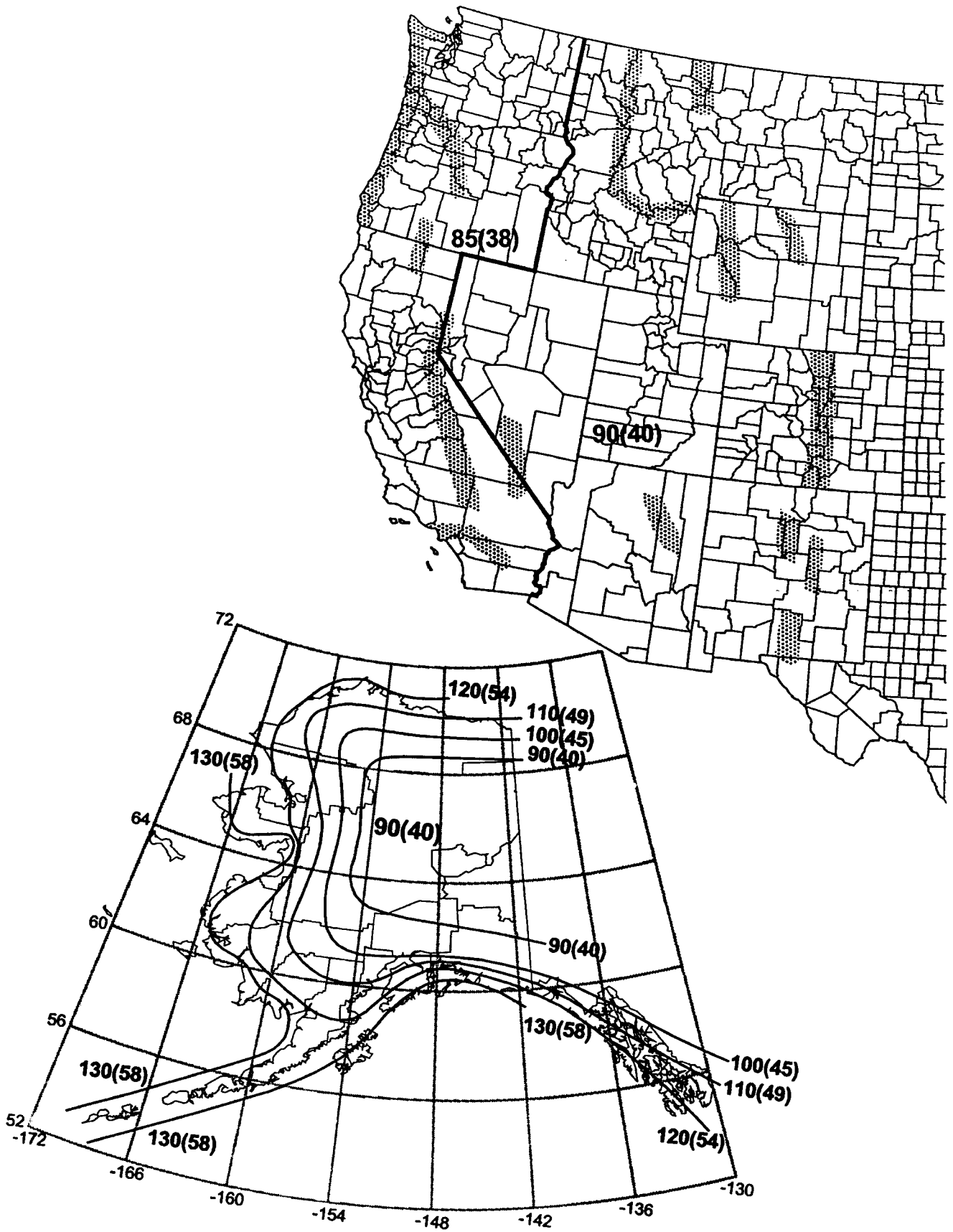
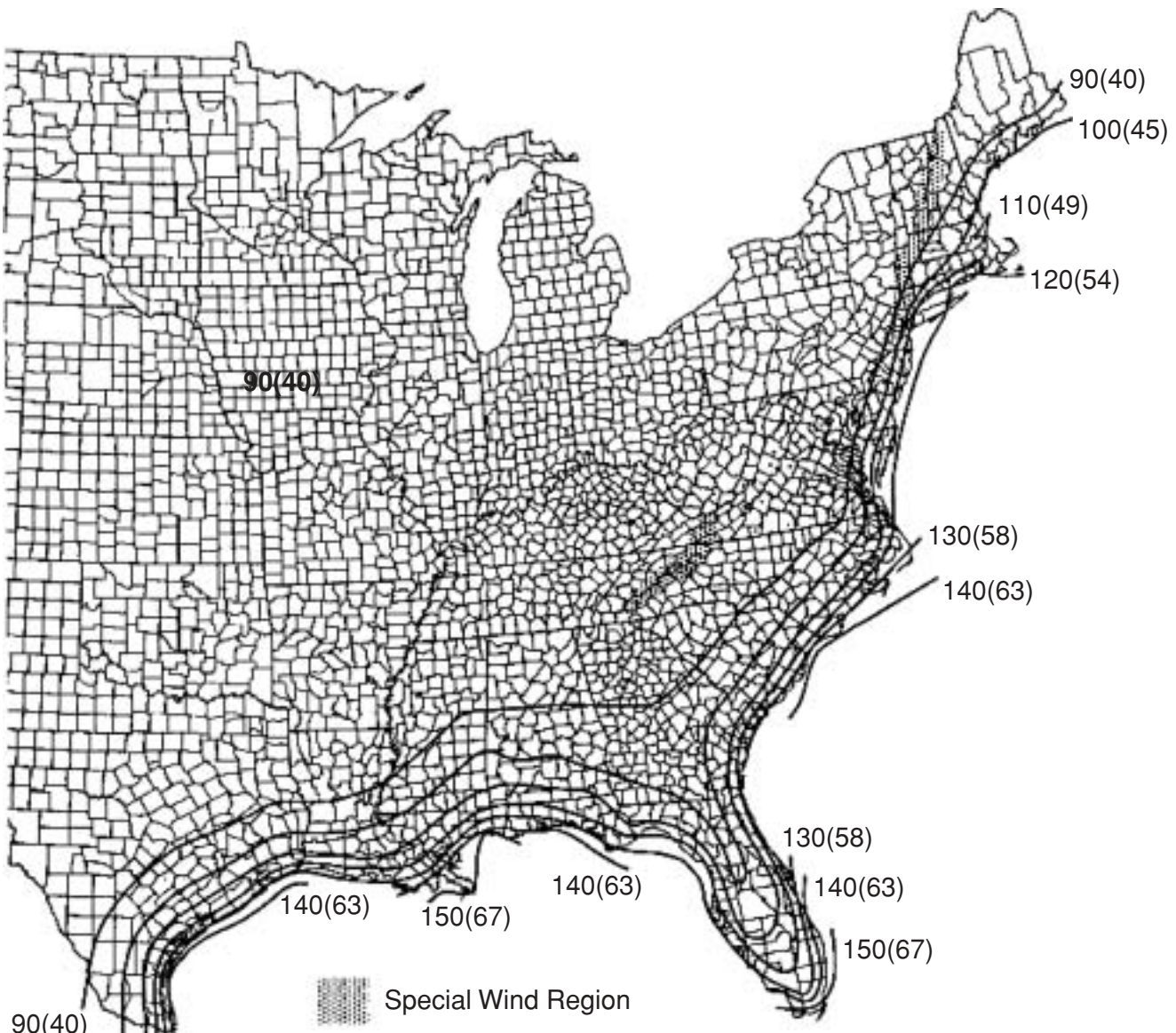



FIGURE 6-1 BASIC WIND SPEED



90(40)
 100(45) 130(58)
 110(49) 120(54)

 Special Wind Region

Location	V mph	(m/s)
Hawaii	105	(47)
Puerto Rico	145	(65)
Guam	170	(76)
Virgin Islands	145	(65)
American Samoa	125	(56)

- Notes:
1. Values are nominal design 3-second gust wind speeds in miles per hour (m/s) at 33 ft (10 m) above ground for Exposure C category.
 2. Linear interpolation between wind contours is permitted.
 3. Islands and coastal areas outside the last contour shall use the last wind speed contour of the coastal area.
 4. Mountainous terrain, gorges, ocean promontories, and special wind regions shall be examined for unusual wind conditions.

FIGURE 6-1 continued
BASIC WIND SPEED

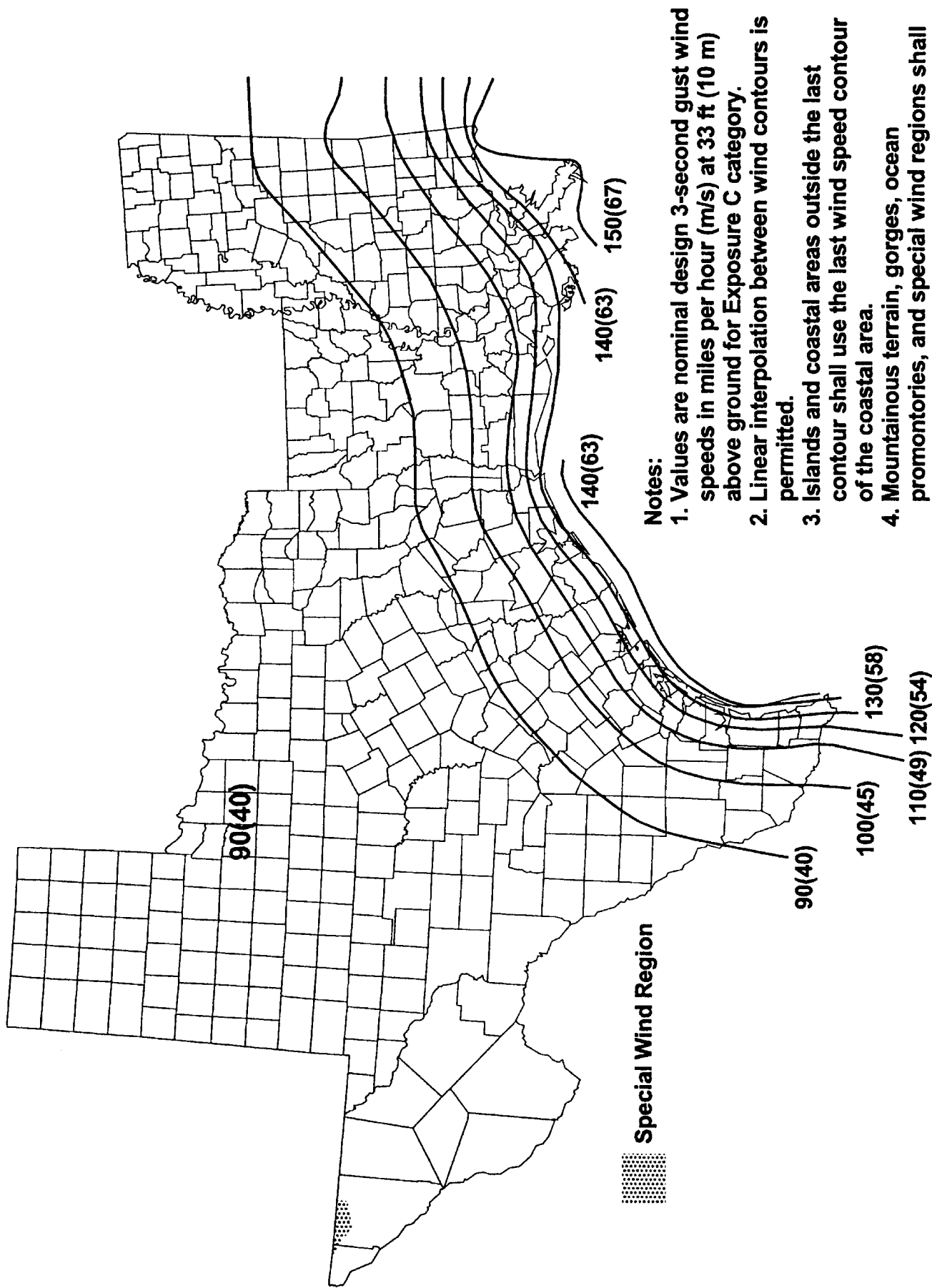

FIGURE 6-1A BASIC WIND SPEED—WESTERN GULF OF MEXICO HURRICANE COASTLINE

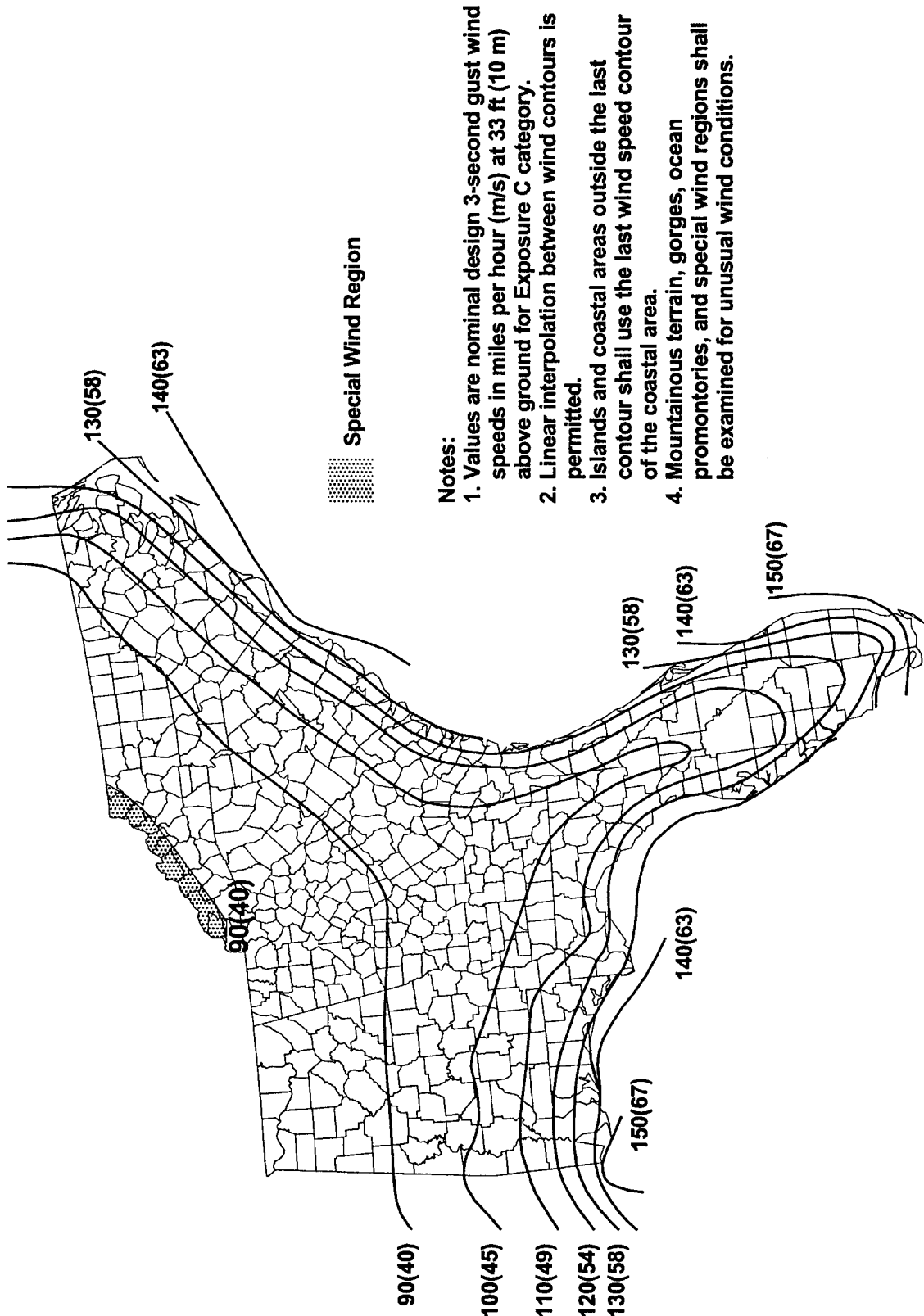
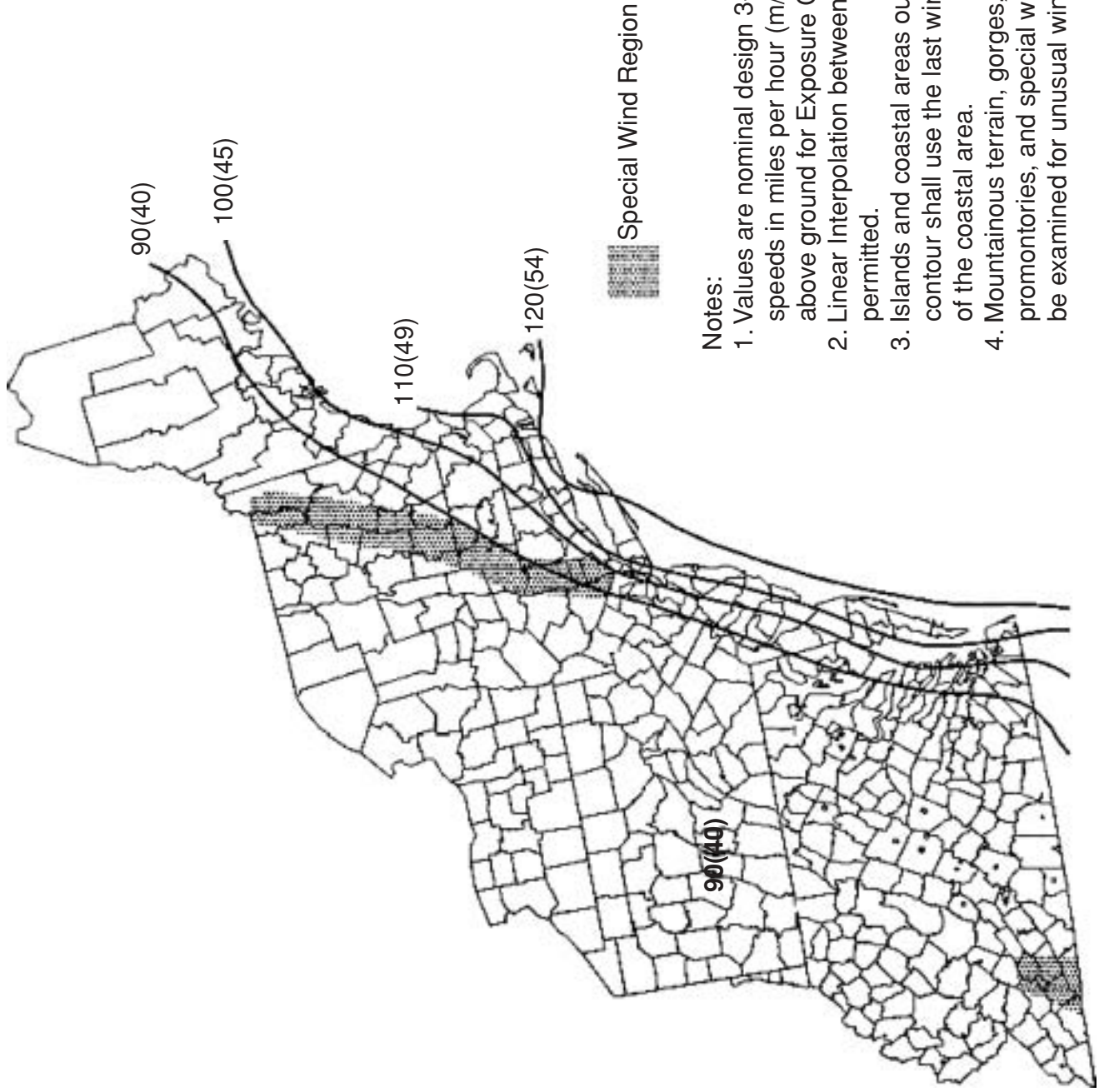

FIGURE 6-1B—BASIC WIND SPEED—EASTERN GULF OF MEXICO AND SOUTHEASTERN US HURRICANE COASTLINE



Notes:

1. Values are nominal design 3-second gust wind speeds in miles per hour (m/s) at 33 ft (10 m) above ground for Exposure C category.
2. Linear Interpolation between wind contours is permitted.
3. Islands and coastal areas outside the last contour shall use the last wind speed contour of the coastal area.
4. Mountainous terrain, gorges, ocean promontories, and special wind regions shall be examined for unusual wind conditions.

FIGURE 6-1C BASIC WIND SPEED—MID AND NORTHERN ATLANTIC HURRICANE COASTLINE

Main Wind Force Resisting System – Method 1						h ≤ 60 ft.						
Figure 6-2 (cont'd)		Design Wind Pressures				Walls & Roofs						
Enclosed Buildings												
Simplified Design Wind Pressure, p_{s30} (psf) (Exposure B at h = 30 ft., $K_{zt} = 1.0$, with $I = 1.0$)												
Basic Wind Speed (mph)	Roof Angle (degrees)	Load Case	Zones									
			Horizontal Pressures				Vertical Pressures				Overhangs	
			A	B	C	D	E	F	G	H	EoH	GoH
85	0 to 5°	1	11.5	-5.9	7.6	-3.5	-13.8	-7.8	-9.6	-6.1	-19.3	-15.1
	10°	1	12.9	-5.4	8.6	-3.1	-13.8	-8.4	-9.6	-6.5	-19.3	-15.1
	15°	1	14.4	-4.8	9.6	-2.7	-13.8	-9.0	-9.6	-6.9	-19.3	-15.1
	20°	1	15.9	-4.2	10.6	-2.3	-13.8	-9.6	-9.6	-7.3	-19.3	-15.1
	25°	1	14.4	2.3	10.4	2.4	-6.4	-8.7	-4.6	-7.0	-11.9	-10.1
		2	-----	-----	-----	-----	-2.4	-4.7	-0.7	-3.0	-----	-----
	30 to 45	1	12.9	8.8	10.2	7.0	1.0	-7.8	0.3	-6.7	-4.5	-5.2
		2	12.9	8.8	10.2	7.0	5.0	-3.9	4.3	-2.8	-4.5	-5.2
90	0 to 5°	1	12.8	-6.7	8.5	-4.0	-15.4	-8.8	-10.7	-6.8	-21.6	-16.9
	10°	1	14.5	-6.0	9.6	-3.5	-15.4	-9.4	-10.7	-7.2	-21.6	-16.9
	15°	1	16.1	-5.4	10.7	-3.0	-15.4	-10.1	-10.7	-7.7	-21.6	-16.9
	20°	1	17.8	-4.7	11.9	-2.6	-15.4	-10.7	-10.7	-8.1	-21.6	-16.9
	25°	1	16.1	2.6	11.7	2.7	-7.2	-9.8	-5.2	-7.8	-13.3	-11.4
		2	-----	-----	-----	-----	-2.7	-5.3	-0.7	-3.4	-----	-----
	30 to 45	1	14.4	9.9	11.5	7.9	1.1	-8.8	0.4	-7.5	-5.1	-5.8
		2	14.4	9.9	11.5	7.9	5.6	-4.3	4.8	-3.1	-5.1	-5.8
100	0 to 5°	1	15.9	-8.2	10.5	-4.9	-19.1	-10.8	-13.3	-8.4	-26.7	-20.9
	10°	1	17.9	-7.4	11.9	-4.3	-19.1	-11.6	-13.3	-8.9	-26.7	-20.9
	15°	1	19.9	-6.6	13.3	-3.8	-19.1	-12.4	-13.3	-9.5	-26.7	-20.9
	20°	1	22.0	-5.8	14.6	-3.2	-19.1	-13.3	-13.3	-10.1	-26.7	-20.9
	25°	1	19.9	3.2	14.4	3.3	-8.8	-12.0	-6.4	-9.7	-16.5	-14.0
		2	-----	-----	-----	-----	-3.4	-6.6	-0.9	-4.2	-----	-----
	30 to 45	1	17.8	12.2	14.2	9.8	1.4	-10.8	0.5	-9.3	-6.3	-7.2
		2	17.8	12.2	14.2	9.8	6.9	-5.3	5.9	-3.8	-6.3	-7.2
105	0 to 5°	1	17.5	-9.0	11.6	-5.4	-21.1	-11.9	-14.7	-9.3	-29.4	-23.0
	10°	1	19.7	-8.2	13.1	-4.7	-21.1	-12.8	-14.7	-9.8	-29.4	-23.0
	15°	1	21.9	-7.3	14.7	-4.2	-21.1	-13.7	-14.7	-10.5	-29.4	-23.0
	20°	1	24.3	-6.4	16.1	-3.5	-21.1	-14.7	-14.7	-11.1	-29.4	-23.0
	25°	1	21.9	3.5	15.9	3.5	-9.7	-13.2	-7.1	-10.7	-18.2	-15.4
		2	-----	-----	-----	-----	-3.7	-7.3	-1.0	-4.6	-----	-----
	30 to 45	1	19.6	13.5	15.7	10.8	1.5	-11.9	0.6	-10.3	-6.9	-7.9
		2	19.6	13.5	15.7	10.8	7.6	-5.8	6.5	-4.2	-6.9	-7.9
110	0 to 5°	1	19.2	-10.0	12.7	-5.9	-23.1	-13.1	-16.0	-10.1	-32.3	-25.3
	10°	1	21.6	-9.0	14.4	-5.2	-23.1	-14.1	-16.0	-10.8	-32.3	-25.3
	15°	1	24.1	-8.0	16.0	-4.6	-23.1	-15.1	-16.0	-11.5	-32.3	-25.3
	20°	1	26.6	-7.0	17.7	-3.9	-23.1	-16.0	-16.0	-12.2	-32.3	-25.3
	25°	1	24.1	3.9	17.4	4.0	-10.7	-14.6	-7.7	-11.7	-19.9	-17.0
		2	-----	-----	-----	-----	-4.1	-7.9	-1.1	-5.1	-----	-----
	30 to 45	1	21.6	14.8	17.2	11.8	1.7	-13.1	0.6	-11.3	-7.6	-8.7
		2	21.6	14.8	17.2	11.8	8.3	-6.5	7.2	-4.6	-7.6	-8.7
120	0 to 5°	1	22.8	-11.9	15.1	-7.0	-27.4	-15.6	-19.1	-12.1	-38.4	-30.1
	10°	1	25.8	-10.7	17.1	-6.2	-27.4	-16.8	-19.1	-12.9	-38.4	-30.1
	15°	1	28.7	-9.5	19.1	-5.4	-27.4	-17.9	-19.1	-13.7	-38.4	-30.1
	20°	1	31.6	-8.3	21.1	-4.6	-27.4	-19.1	-19.1	-14.5	-38.4	-30.1
	25°	1	28.6	4.6	20.7	4.7	-12.7	-17.3	-9.2	-13.9	-23.7	-20.2
		2	-----	-----	-----	-----	-4.8	-9.4	-1.3	-6.0	-----	-----
	30 to 45	1	25.7	17.6	20.4	14.0	2.0	-15.6	0.7	-13.4	-9.0	-10.3
		2	25.7	17.6	20.4	14.0	9.9	-7.7	8.6	-5.5	-9.0	-10.3

Unit Conversions—1.0 ft = 0.3048 m; 1.0 psf = 0.0479 kN/m²

Main Wind Force Resisting System – Method 1						h ≤ 60 ft.						
Figure 6-2 (cont'd)		Design Wind Pressures				Walls & Roofs						
Enclosed Buildings												
Simplified Design Wind Pressure, p_{s30} (psf) (Exposure B at h = 30 ft., $K_{zt} = 1.0$, with $I = 1.0$)												
Basic Wind Speed (mph)	Roof Angle (degrees)	Load Case	Zones									
			Horizontal Pressures				Vertical Pressures				Overhangs	
			A	B	C	D	E	F	G	H	EOH	GOH
125	0 to 5°	1	24.7	-12.9	16.4	-7.6	-29.7	-16.9	-20.7	-13.1	-41.7	-32.7
	10°	1	28.0	-11.6	18.6	-6.7	-29.7	-18.2	-20.7	-14.0	-41.7	-32.7
	15°	1	31.1	-10.3	20.7	-5.9	-29.7	-19.4	-20.7	-14.9	-41.7	-32.7
	20°	1	34.3	-9.0	22.9	-5.0	-29.7	-20.7	-20.7	-15.7	-41.7	-32.7
	25°	1	31.0	5.0	22.5	5.1	-13.8	-18.8	-10.0	-15.1	-25.7	-21.9
			2	-----	-----	-----	-----	-5.2	-10.2	-1.4	-6.5	-----
130	30 to 45	1	27.9	19.1	22.1	15.2	2.2	-16.9	0.8	-14.5	-9.8	-11.2
		2	27.9	19.1	22.1	15.2	10.7	-8.4	9.3	-6.0	-9.8	-11.2
	0 to 5°	1	26.8	-13.9	17.8	-8.2	-32.2	-18.3	-22.4	-14.2	-45.1	-35.3
	10°	1	30.2	-12.5	20.1	-7.3	-32.2	-19.7	-22.4	-15.1	-45.1	-35.3
	15°	1	33.7	-11.2	22.4	-6.4	-32.2	-21.0	-22.4	-16.1	-45.1	-35.3
	20°	1	37.1	-9.8	24.7	-5.4	-32.2	-22.4	-22.4	-17.0	-45.1	-35.3
140	25°	1	33.6	5.4	24.3	5.5	-14.9	-20.4	-10.8	-16.4	-27.8	-23.7
		2	-----	-----	-----	-----	-5.7	-11.1	-1.5	-7.1	-----	-----
	30 to 45	1	30.1	20.6	24.0	16.5	2.3	-18.3	0.8	-15.7	-10.6	-12.1
		2	30.1	20.6	24.0	16.5	11.6	-9.0	10.0	-6.4	-10.6	-12.1
	0 to 5°	1	31.1	-16.1	20.6	-9.6	-37.3	-21.2	-26.0	-16.4	-52.3	-40.9
	10°	1	35.1	-14.5	23.3	-8.5	-37.3	-22.8	-26.0	-17.5	-52.3	-40.9
145	15°	1	39.0	-12.9	26.0	-7.4	-37.3	-24.4	-26.0	-18.6	-52.3	-40.9
	20°	1	43.0	-11.4	28.7	-6.3	-37.3	-26.0	-26.0	-19.7	-52.3	-40.9
	25°	1	39.0	6.3	28.2	6.4	-17.3	-23.6	-12.5	-19.0	-32.3	-27.5
		2 ⁴	-----	-----	-----	-----	-6.6	-12.8	-1.8	-8.2	-----	-----
	30 to 45	1	35.0	23.9	27.8	19.1	2.7	-21.2	0.9	-18.2	-12.3	-14.0
		2 ⁴	35.0	23.9	27.8	19.1	13.4	-10.5	11.7	-7.5	-12.3	-14.0
150	0 to 5°	1	33.4	-17.3	22.1	-10.3	-40.0	-22.7	-27.9	-17.6	-56.1	-43.9
	10°	1	37.7	-15.6	25.0	-9.1	-40.0	-24.5	-27.9	-18.8	-56.1	-43.9
	15°	1	41.8	-13.8	27.9	-7.9	-40.0	-26.2	-27.9	-20.0	-56.1	-43.9
	20°	1	46.1	-12.2	30.8	-6.8	-40.0	-27.9	-27.9	-21.1	-56.1	-43.9
	25°	1	41.8	6.8	30.3	6.9	-18.6	-25.3	-13.4	-20.4	-34.6	-29.5
		2 ⁴	-----	-----	-----	-----	-7.1	-13.7	-1.9	-8.8	-----	-----
155	30 to 45	1	37.5	25.6	29.8	20.5	2.9	-22.7	1.0	-19.5	-13.2	-15.0
		2 ⁴	35.7	25.6	29.8	20.5	14.4	-11.3	12.6	-8.0	-13.2	-15.0
	0 to 5°	1	35.7	-18.5	23.7	-11.0	-42.9	-24.4	-29.8	-18.9	-60.0	-47.0
	10°	1	40.2	-16.7	26.8	-9.7	-42.9	-26.2	-29.8	-20.1	-60.0	-47.0
	15°	1	44.8	-14.9	29.8	-8.5	-42.9	-28.0	-29.8	-21.4	-60.0	-47.0
	20°	1	49.4	-13.0	32.9	-7.2	-42.9	-29.8	-29.8	-22.6	-60.0	-47.0
160	25°	1	44.8	7.2	32.4	7.4	-19.9	-27.1	-14.4	-21.8	-37.0	-31.6
		2 ⁴	-----	-----	-----	-----	-7.5	-14.7	-2.1	-9.4	-----	-----
	30 to 45	1	40.1	27.4	31.9	22.0	3.1	-24.4	1.0	-20.9	-14.1	-16.1
		2 ⁴	40.1	27.4	31.9	22.0	15.4	-12.0	13.4	-8.6	-14.1	-16.1
	0 to 5°	1	45.8	-23.8	30.4	-14.1	-55.1	-31.3	-38.3	-24.2	-77.1	-60.4
	10°	1	51.7	-21.4	34.4	-12.5	-55.1	-33.6	-38.3	-25.8	-77.1	-60.4
170	15°	1	57.6	-19.1	38.3	-10.9	-55.1	-36.0	-38.3	-27.5	-77.1	-60.4
	20°	1	63.4	-16.7	42.3	-9.3	-55.1	-38.3	-38.3	-29.1	-77.1	-60.4
	25°	1	57.5	9.3	41.6	9.5	-25.6	-34.8	-18.5	-28.0	-47.6	-40.5
		2 ⁴	-----	-----	-----	-----	-9.7	-18.9	-2.6	-12.1	-----	-----
	30 to 45	1	51.5	35.2	41.0	28.2	4.0	-31.3	1.3	-26.9	-18.1	-20.7
		2 ⁴	51.5	35.2	41.0	28.2	19.8	-15.4	17.2	-11.0	-18.1	-20.7

Unit Conversions—1.0 ft = 0.3048 m; 1.0 psf = 0.0479 kN/m²

Main Wind Force Resisting System – Method 1		$h \leq 60$ ft.
Figure 6-2 (cont'd)	Design Wind Pressures	Walls & Roofs
Enclosed Buildings		

Adjustment Factor for Building Height and Exposure, λ			
Mean roof height (ft)	Exposure		
	B	C	D
15	1.00	1.21	1.47
20	1.00	1.29	1.55
25	1.00	1.35	1.61
30	1.00	1.40	1.66
35	1.05	1.45	1.70
40	1.09	1.49	1.74
45	1.12	1.53	1.78
50	1.16	1.56	1.81
55	1.19	1.59	1.84
60	1.22	1.62	1.87

Components and Cladding – Method 1		h ≤ 60 ft.
Figure 6-3 (cont'd)	Net Design Wind Pressures	Walls & Roofs
Enclosed Buildings		

Net Design Wind Pressure, p_{net30} (psf) (Exposure B at $h = 30$ ft. with $I = 1.0$ and $K_{zt} = 1.0$)

	Zone	Effective wind area (sf)	Basic Wind Speed V (mph)											
			85		90		100		105		110		120	
			+	-	+	-	+	-	+	-	+	-	+	-
Roof 0 to 7 degrees	1	10	5.3	-13.0	5.9	-14.6	7.3	-18.0	8.1	-19.8	8.9	-21.8	10.5	-25.9
	1	20	5.0	-12.7	5.6	-14.2	6.9	-17.5	7.6	-19.3	8.3	-21.2	9.9	-25.2
	1	50	4.5	-12.2	5.1	-13.7	6.3	-16.9	6.9	-18.7	7.6	-20.5	9.0	-24.4
	1	100	4.2	-11.9	4.7	-13.3	5.8	-16.5	6.4	-18.2	7.0	-19.9	8.3	-23.7
	2	10	5.3	-21.8	5.9	-24.4	7.3	-30.2	8.1	-33.3	8.9	-36.5	10.5	-43.5
	2	20	5.0	-19.5	5.6	-21.8	6.9	-27.0	7.6	-29.7	8.3	-32.6	9.9	-38.8
	2	50	4.5	-16.4	5.1	-18.4	6.3	-22.7	6.9	-25.1	7.6	-27.5	9.0	-32.7
	2	100	4.2	-14.1	4.7	-15.8	5.8	-19.5	6.4	-21.5	7.0	-23.6	8.3	-28.1
	3	10	5.3	-32.8	5.9	-36.8	7.3	-45.4	8.1	-50.1	8.9	-55.0	10.5	-65.4
	3	20	5.0	-27.2	5.6	-30.5	6.9	-37.6	7.6	-41.5	8.3	-45.5	9.9	-54.2
	3	50	4.5	-19.7	5.1	-22.1	6.3	-27.3	6.9	-30.1	7.6	-33.1	9.0	-39.3
	3	100	4.2	-14.1	4.7	-15.8	5.8	-19.5	6.4	-21.5	7.0	-23.6	8.3	-28.1
Roof > 7 to 27 degrees	1	10	7.5	-11.9	8.4	-13.3	10.4	-16.5	11.4	-18.2	12.5	-19.9	14.9	-23.7
	1	20	6.8	-11.6	7.7	-13.0	9.4	-16.0	10.4	-17.6	11.4	-19.4	13.6	-23.0
	1	50	6.0	-11.1	6.7	-12.5	8.2	-15.4	9.1	-17.0	10.0	-18.6	11.9	-22.2
	1	100	5.3	-10.8	5.9	-12.1	7.3	-14.9	8.1	-16.5	8.9	-18.1	10.5	-21.5
	2	10	7.5	-20.7	8.4	-23.2	10.4	-28.7	11.4	-31.6	12.5	-34.7	14.9	-41.3
	2	20	6.8	-19.0	7.7	-21.4	9.4	-26.4	10.4	-29.1	11.4	-31.9	13.6	-38.0
	2	50	6.0	-16.9	6.7	-18.9	8.2	-23.3	9.1	-25.7	10.0	-28.2	11.9	-33.6
	2	100	5.3	-15.2	5.9	-17.0	7.3	-21.0	8.1	-23.2	8.9	-25.5	10.5	-30.3
	3	10	7.5	-30.6	8.4	-34.3	10.4	-42.4	11.4	-46.7	12.5	-51.3	14.9	-61.0
	3	20	6.8	-28.6	7.7	-32.1	9.4	-39.6	10.4	-43.7	11.4	-47.9	13.6	-57.1
	3	50	6.0	-26.0	6.7	-29.1	8.2	-36.0	9.1	-39.7	10.0	-43.5	11.9	-51.8
	3	100	5.3	-24.0	5.9	-26.9	7.3	-33.2	8.1	-36.6	8.9	-40.2	10.5	-47.9
Roof > 27 to 45 degrees	1	10	11.9	-13.0	13.3	-14.6	16.5	-18.0	18.2	-19.8	19.9	-21.8	23.7	-25.9
	1	20	11.6	-12.3	13.0	-13.8	16.0	-17.1	17.6	-18.8	19.4	-20.7	23.0	-24.6
	1	50	11.1	-11.5	12.5	-12.8	15.4	-15.9	17.0	-17.5	18.6	-19.2	22.2	-22.8
	1	100	10.8	-10.8	12.1	-12.1	14.9	-14.9	16.5	-16.5	18.1	-18.1	21.5	-21.5
	2	10	11.9	-15.2	13.3	-17.0	16.5	-21.0	18.2	-23.2	19.9	-25.5	23.7	-30.3
	2	20	11.6	-14.5	13.0	-16.3	16.0	-20.1	17.6	-22.2	19.4	-24.3	23.0	-29.0
	2	50	11.1	-13.7	12.5	-15.3	15.4	-18.9	17.0	-20.8	18.6	-22.9	22.2	-27.2
	2	100	10.8	-13.0	12.1	-14.6	14.9	-18.0	16.5	-19.8	18.1	-21.8	21.5	-25.9
	3	10	11.9	-15.2	13.3	-17.0	16.5	-21.0	18.2	-23.2	19.9	-25.5	23.7	-30.3
	3	20	11.6	-14.5	13.0	-16.3	16.0	-20.1	17.6	-22.2	19.4	-24.3	23.0	-29.0
	3	50	11.1	-13.7	12.5	-15.3	15.4	-18.9	17.0	-20.8	18.6	-22.9	22.2	-27.2
	3	100	10.8	-13.0	12.1	-14.6	14.9	-18.0	16.5	-19.8	18.1	-21.8	21.5	-25.9
Wall	4	10	13.0	-14.1	14.6	-15.8	18.0	-19.5	19.8	-21.5	21.8	-23.6	25.9	-28.1
	4	20	12.4	-13.5	13.9	-15.1	17.2	-18.7	18.9	-20.6	20.8	-22.6	24.7	-26.9
	4	50	11.6	-12.7	13.0	-14.3	16.1	-17.6	17.8	-19.4	19.5	-21.3	23.2	-25.4
	4	100	11.1	-12.2	12.4	-13.6	15.3	-16.8	16.9	-18.5	18.5	-20.4	22.0	-24.2
	4	500	9.7	-10.8	10.9	-12.1	13.4	-14.9	14.8	-16.5	16.2	-18.1	19.3	-21.5
	5	10	13.0	-17.4	14.6	-19.5	18.0	-24.1	19.8	-26.6	21.8	-29.1	25.9	-34.7
	5	20	12.4	-16.2	13.9	-18.2	17.2	-22.5	18.9	-24.8	20.8	-27.2	24.7	-32.4
	5	50	11.6	-14.7	13.0	-16.5	16.1	-20.3	17.8	-22.4	19.5	-24.6	23.2	-29.3
	5	100	11.1	-13.5	12.4	-15.1	15.3	-18.7	16.9	-20.6	18.5	-22.6	22.0	-26.9
	5	500	9.7	-10.8	10.9	-12.1	13.4	-14.9	14.8	-16.5	16.2	-18.1	19.3	-21.5

Unit Conversions – 1.0 ft = 0.3048 m; 1.0 psf = 0.0479 kN/m²

Net Design Wind Pressure, p_{net30} (psf) (Exposure B at $h = 30$ ft. with $I = 1.0$ and $K_{zt} = 1.0$)

	Zone	Effective wind area (sf)	Basic Wind Speed V (mph)											
			125		130		140		145		150		170	
			+	-	+	-	+	-	+	-	+	-	+	-
Roof 0 to 7 degrees	1	10	11.4	-28.1	12.4	-30.4	14.3	-35.3	15.4	-37.8	16.5	-40.5	21.1	-52.0
	1	20	10.7	-27.4	11.6	-29.6	13.4	-34.4	14.4	-36.9	15.4	-39.4	19.8	-50.7
	1	50	9.8	-26.4	10.6	-28.6	12.3	-33.2	13.1	-35.6	14.1	-38.1	18.1	-48.9
	1	100	9.1	-25.7	9.8	-27.8	11.4	-32.3	12.2	-34.6	13.0	-37.0	16.7	-47.6
	2	10	11.4	-47.2	12.4	-51.0	14.3	-59.2	15.4	-63.5	16.5	-67.9	21.1	-87.2
	2	20	10.7	-42.1	11.6	-45.6	13.4	-52.9	14.4	-56.7	15.4	-60.7	19.8	-78.0
	2	50	9.8	-35.5	10.6	-38.4	12.3	-44.5	13.1	-47.8	14.1	-51.1	18.1	-65.7
	2	100	9.1	-30.5	9.8	-33.0	11.4	-38.2	12.2	-41.0	13.0	-43.9	16.7	-56.4
	3	10	11.4	-71.0	12.4	-76.8	14.3	-89.0	15.4	-95.5	16.5	-102.2	21.1	-131.3
	3	20	10.7	-58.5	11.6	-63.6	13.4	-73.8	14.4	-79.1	15.4	-84.7	19.8	-108.7
	3	50	9.8	-42.7	10.6	-46.2	12.3	-53.5	13.1	-57.4	14.1	-61.5	18.1	-78.9
	3	100	9.1	-30.5	9.8	-33.0	11.4	-38.2	12.2	-41.0	13.0	-43.9	16.7	-56.4
Roof > 7 to 27 degrees	1	10	16.2	-25.7	17.5	-27.8	20.3	-32.3	21.8	-34.6	23.3	-37.0	30.0	-47.6
	1	20	14.8	-25.0	16.0	-27.0	18.5	-31.4	19.9	-33.7	21.3	-36.0	27.3	-46.3
	1	50	12.9	-24.1	13.9	-26.0	16.1	-30.2	17.3	-32.4	18.5	-34.6	23.8	-44.5
	1	100	11.4	-23.2	12.4	-25.2	14.3	-29.3	15.4	-31.4	16.5	-33.6	21.1	-43.2
	2	10	16.2	-44.8	17.5	-48.4	20.3	-56.2	21.8	-60.3	23.3	-64.5	30.0	-82.8
	2	20	14.8	-41.2	16.0	-44.6	18.5	-51.7	19.9	-55.4	21.3	-59.3	27.3	-76.2
	2	50	12.9	-36.5	13.9	-39.4	16.1	-45.7	17.3	-49.1	18.5	-52.5	23.8	-67.4
	2	100	11.4	-32.9	12.4	-35.6	14.3	-41.2	15.4	-44.2	16.5	-47.3	21.1	-60.8
	3	10	16.2	-66.2	17.5	-71.6	20.3	-83.1	21.8	-89.1	23.3	-95.4	30.0	-122.5
	3	20	14.8	-61.9	16.0	-67.0	18.5	-77.7	19.9	-83.3	21.3	-89.2	27.3	-114.5
	3	50	12.9	-56.2	13.9	-60.8	16.1	-70.5	17.3	-75.7	18.5	-81.0	23.8	-104.0
	3	100	11.4	-51.9	12.4	-56.2	14.3	-65.1	15.4	-69.9	16.5	-74.8	21.1	-96.0
Roof > 27 to 45 degrees	1	10	25.7	-28.1	27.8	-30.4	32.3	-35.3	34.6	-37.8	37.0	-40.5	47.6	-52.0
	1	20	25.0	-26.7	27.0	-28.9	31.4	-33.5	33.7	-35.9	36.0	-38.4	46.3	-49.3
	1	50	24.1	-24.8	26.0	-26.8	30.2	-31.1	32.4	-33.3	34.6	-35.7	44.5	-45.8
	1	100	23.3	-23.3	25.2	-25.2	29.3	-29.3	31.4	-31.4	33.6	-33.6	43.2	-43.2
	2	10	25.7	-32.9	27.8	-35.6	32.3	-41.2	34.6	-44.2	37.0	-47.3	47.6	-60.8
	2	20	25.0	-31.4	27.0	-34.0	31.4	-39.4	33.7	-42.3	36.0	-45.3	46.3	-58.1
	2	50	24.1	-29.5	26.0	-32.0	30.2	-37.1	32.4	-39.8	34.6	-42.5	44.5	-54.6
	2	100	23.2	-28.1	25.2	-30.4	29.3	-35.3	31.4	-37.8	33.6	-40.5	43.2	-52.0
	3	10	25.7	-32.9	27.8	-35.6	32.3	-41.2	34.6	-44.2	37.0	-47.3	47.6	-60.8
	3	20	25.0	-31.4	27.0	-34.0	31.4	-39.4	33.7	-42.3	36.0	-45.3	46.3	-58.1
	3	50	24.1	-29.5	26.0	-32.0	30.2	-37.1	32.4	-39.8	34.6	-42.5	44.5	-54.6
	3	100	23.3	-28.1	25.2	-30.4	29.3	-35.3	31.4	-37.8	33.6	-40.5	43.2	-52.0
Wall	4	10	28.1	-30.5	30.4	-33.0	35.3	-38.2	37.8	-41.0	40.5	-43.9	52.0	-56.4
	4	20	26.8	-29.2	29.0	-31.6	33.7	-36.7	36.1	-39.3	38.7	-42.1	49.6	-54.1
	4	50	25.2	-27.5	27.2	-29.8	31.6	-34.6	33.9	-37.1	36.2	-39.7	46.6	-51.0
	4	100	23.9	-26.3	25.9	-28.4	30.0	-33.0	32.2	-35.4	34.4	-37.8	44.2	-48.6
	4	500	21.0	-23.3	22.7	-25.2	26.3	-29.3	28.2	-31.4	30.2	-33.6	38.8	-43.2
	5	10	28.1	-37.6	30.4	-40.7	35.3	-47.2	37.8	-50.6	40.5	-54.2	52.0	-69.6
	5	20	26.8	-35.1	29.0	-38.0	33.7	-44.0	36.1	-47.2	38.7	-50.5	49.6	-64.9
	5	50	25.2	-31.8	27.2	-34.3	31.6	-39.8	33.9	-42.7	36.2	-45.7	46.6	-58.7
	5	100	23.9	-29.2	25.9	-31.6	30.0	-36.7	32.2	-39.3	34.4	-42.1	44.2	-54.1
	5	500	21.0	-23.2	22.7	-25.2	26.3	-29.3	28.2	-31.1	30.2	-33.6	38.8	-43.2

Unit Conversions – 1.0 ft = 0.3048 m; 1.0 psf = 0.0479 kN/m²

Components and Cladding – Method 1		h ≤ 60 ft.
Figure 6-3 (cont'd)	Net Design Wind Pressures	Walls & Roofs
Enclosed Buildings		

Roof Overhang Net Design Wind Pressure , p_{net30} (psf)

(Exposure B at h = 30 ft. with I = 1.0)

	Zone	Effective Wind Area (sf)	Basic Wind Speed V (mph)							
			90	100	110	120	130	140	150	170
Roof 0 to 7 degrees	2	10	-21.0	-25.9	-31.4	-37.3	-43.8	-50.8	-58.3	-74.9
	2	20	-20.6	-25.5	-30.8	-36.7	-43.0	-49.9	-57.3	-73.6
	2	50	-20.1	-24.9	-30.1	-35.8	-42.0	-48.7	-55.9	-71.8
	2	100	-19.8	-24.4	-29.5	-35.1	-41.2	-47.8	-54.9	-70.5
	3	10	-34.6	-42.7	-51.6	-61.5	-72.1	-83.7	-96.0	-123.4
	3	20	-27.1	-33.5	-40.5	-48.3	-56.6	-65.7	-75.4	-96.8
	3	50	-17.3	-21.4	-25.9	-30.8	-36.1	-41.9	-48.1	-61.8
	3	100	-10.0	-12.2	-14.8	-17.6	-20.6	-23.9	-27.4	-35.2
Roof > 7 to 27 degrees	2	10	-27.2	-33.5	-40.6	-48.3	-56.7	-65.7	-75.5	-96.9
	2	20	-27.2	-33.5	-40.6	-48.3	-56.7	-65.7	-75.5	-96.9
	2	50	-27.2	-33.5	-40.6	-48.3	-56.7	-65.7	-75.5	-96.9
	2	100	-27.2	-33.5	-40.6	-48.3	-56.7	-65.7	-75.5	-96.9
	3	10	-45.7	-56.4	-68.3	-81.2	-95.3	-110.6	-126.9	-163.0
	3	20	-41.2	-50.9	-61.6	-73.3	-86.0	-99.8	-114.5	-147.1
	3	50	-35.3	-43.6	-52.8	-62.8	-73.7	-85.5	-98.1	-126.1
	3	100	-30.9	-38.1	-46.1	-54.9	-64.4	-74.7	-85.8	-110.1
Roof > 27 to 45 degrees	2	10	-24.7	-30.5	-36.9	-43.9	-51.5	-59.8	-68.6	-88.1
	2	20	-24.0	-29.6	-35.8	-42.6	-50.0	-58.0	-66.5	-85.5
	2	50	-23.0	-28.4	-34.3	-40.8	-47.9	-55.6	-63.8	-82.0
	2	100	-22.2	-27.4	-33.2	-39.5	-46.4	-53.8	-61.7	-79.3
	3	10	-24.7	-30.5	-36.9	-43.9	-51.5	-59.8	-68.6	-88.1
	3	20	-24.0	-29.6	-35.8	-42.6	-50.0	-58.0	-66.5	-85.5
	3	50	-23.0	-28.4	-34.3	-40.8	-47.9	-55.6	-63.8	-82.0
	3	100	-22.2	-27.4	-33.2	-39.5	-46.4	-53.8	-61.7	-79.3

**Adjustment Factor
for Building Height and Exposure, λ**

Mean roof height (ft)	Exposure		
	B	C	D
15	1.00	1.21	1.47
20	1.00	1.29	1.55
25	1.00	1.35	1.61
30	1.00	1.40	1.66
35	1.05	1.45	1.70
40	1.09	1.49	1.74
45	1.12	1.53	1.78
50	1.16	1.56	1.81
55	1.19	1.59	1.84
60	1.22	1.62	1.87

Unit Conversions – 1.0 ft = 0.3048 m; 1.0 sf = 0.0929 m²; 1.0 psf = 0.0479 kN/m

Topographic Factor, K_{zt} – Method 2

Figure 6-4

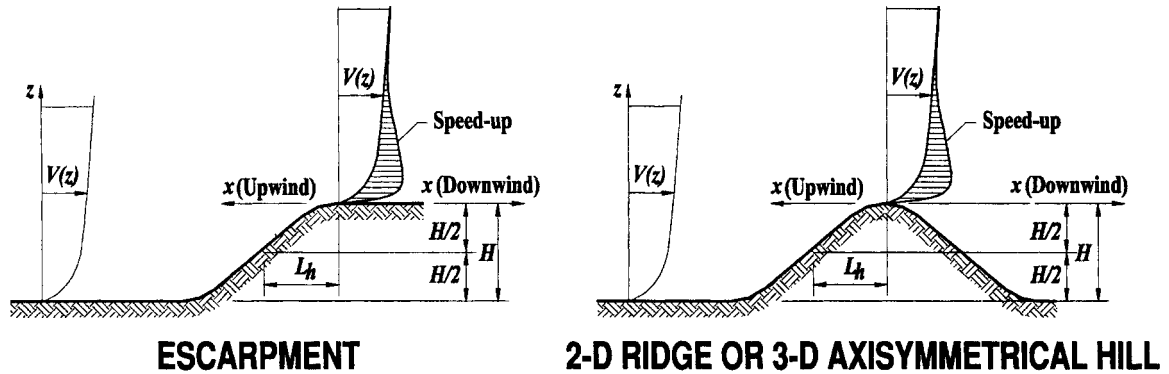

Topographic Multipliers for Exposure C

H/L_h	K_1 Multiplier			x/L_h	K_2 Multiplier		z/L_h	K_3 Multiplier		
	2-D Ridge	2-D Escarp.	3-D Axisym. Hill		2-D Escarp.	All Other Cases		2-D Ridge	2-D Escarp.	3-D Axisym. Hill
0.20	0.29	0.17	0.21	0.00	1.00	1.00	0.00	1.00	1.00	1.00
0.25	0.36	0.21	0.26	0.50	0.88	0.67	0.10	0.74	0.78	0.67
0.30	0.43	0.26	0.32	1.00	0.75	0.33	0.20	0.55	0.61	0.45
0.35	0.51	0.30	0.37	1.50	0.63	0.00	0.30	0.41	0.47	0.30
0.40	0.58	0.34	0.42	2.00	0.50	0.00	0.40	0.30	0.37	0.20
0.45	0.65	0.38	0.47	2.50	0.38	0.00	0.50	0.22	0.29	0.14
0.50	0.72	0.43	0.53	3.00	0.25	0.00	0.60	0.17	0.22	0.09
				3.50	0.13	0.00	0.70	0.12	0.17	0.06
				4.00	0.00	0.00	0.80	0.09	0.14	0.04
							0.90	0.07	0.11	0.03
							1.00	0.05	0.08	0.02
							1.50	0.01	0.02	0.00
							2.00	0.00	0.00	0.00

Notes:

- For values of H/L_h , x/L_h and z/L_h other than those shown, linear interpolation is permitted.
- For $H/L_h > 0.5$, assume $H/L_h = 0.5$ for evaluating K_1 and substitute $2H$ for L_h for evaluating K_2 and K_3 .
- Multipliers are based on the assumption that wind approaches the hill or escarpment along the direction of maximum slope.
- Notation:
 H : Height of hill or escarpment relative to the upwind terrain, in feet (meters).
 L_h : Distance upwind of crest to where the difference in ground elevation is half the height of hill or escarpment, in feet (meters).
 K_1 : Factor to account for shape of topographic feature and maximum speed-up effect.
 K_2 : Factor to account for reduction in speed-up with distance upwind or downwind of crest.
 K_3 : Factor to account for reduction in speed-up with height above local terrain.
 x : Distance (upwind or downwind) from the crest to the building site, in feet (meters).
 z : Height above local ground level, in feet (meters).
 μ : Horizontal attenuation factor.
 γ : Height attenuation factor.

Topographic Factor, K_{zt} – Method 2

Figure 6-4 (cont'd)

Equations:

$$K_{zt} = (1 + K_1 K_2 K_3)^2$$

K_1 determined from table below

$$K_2 = \left(1 - \frac{|x|}{\mu L_h}\right)$$

$$K_3 = e^{-\gamma z/L_h}$$

Parameters for Speed-Up Over Hills and Escarpments

Hill Shape	$K_1/(H/L_h)$			γ	μ	
	Exposure				Upwind of Crest	Downwind of Crest
	B	C	D			
2-dimensional ridges (or valleys with negative H in $K_1/(H/L_h)$)	1.30	1.45	1.55	3	1.5	1.5
2-dimensional escarpments	0.75	0.85	0.95	2.5	1.5	4
3-dimensional axisym. hill	0.95	1.05	1.15	4	1.5	1.5

Main Wind Force Res. Sys. / Comp and Clad. – Method 2		All Heights								
Figure 6-5	Internal Pressure Coefficient, GC_{pi}	Walls & Roofs								
Enclosed, Partially Enclosed, and Open Buildings										
<table border="1"> <thead> <tr> <th>Enclosure Classification</th> <th>GC_{pi}</th> </tr> </thead> <tbody> <tr> <td>Open Buildings</td> <td>0.00</td> </tr> <tr> <td>Partially Enclosed Buildings</td> <td>+0.55 -0.55</td> </tr> <tr> <td>Enclosed Buildings</td> <td>+0.18 -0.18</td> </tr> </tbody> </table>			Enclosure Classification	GC_{pi}	Open Buildings	0.00	Partially Enclosed Buildings	+0.55 -0.55	Enclosed Buildings	+0.18 -0.18
Enclosure Classification	GC_{pi}									
Open Buildings	0.00									
Partially Enclosed Buildings	+0.55 -0.55									
Enclosed Buildings	+0.18 -0.18									
<p>Notes:</p> <ol style="list-style-type: none"> 1. Plus and minus signs signify pressures acting toward and away from the internal surfaces, respectively. 2. Values of GC_{pi} shall be used with q_z or q_h as specified in 6.5.12. 3. Two cases shall be considered to determine the critical load requirements for the appropriate condition: <ol style="list-style-type: none"> (i) a positive value of GC_{pi} applied to all internal surfaces (ii) a negative value of GC_{pi} applied to all internal surfaces 										

Main Wind Force Resisting System – Method 2		All Heights
Figure 6-6	External Pressure Coefficients, C_p	Walls & Roofs
Enclosed, Partially Enclosed Buildings		

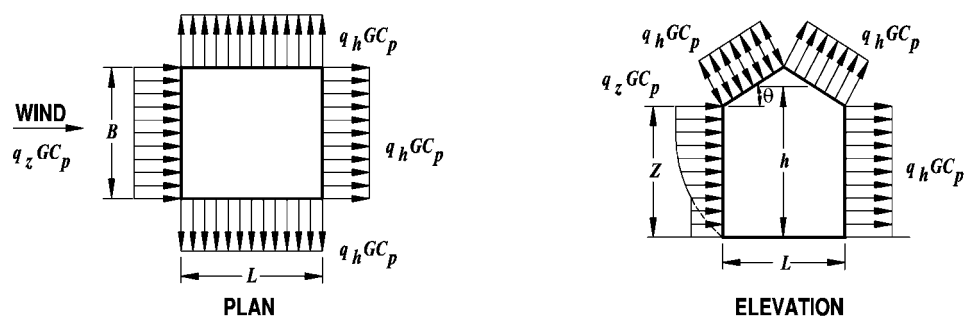

GABLE, HIP ROOF

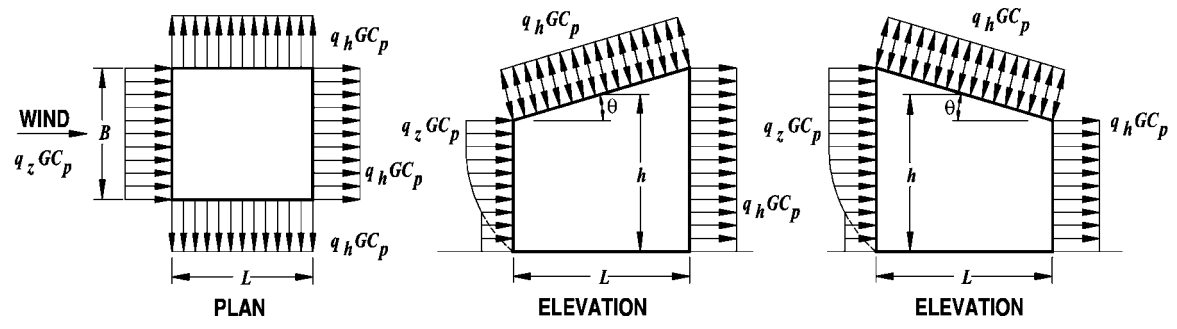

MONOSLOPE ROOF (NOTE 4)

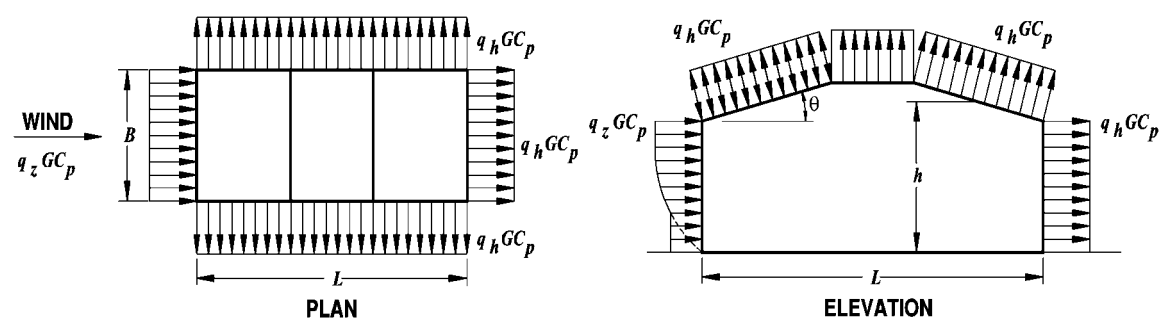

MANSARD ROOF (NOTE 8)

Main Wind Force Resisting System – Method 2								All Heights				
Figure 6-6 (con't)			External Pressure Coefficients, C_p					Walls & Roofs				
Enclosed, Partially Enclosed Buildings												
Wall Pressure Coefficients, C_p												
Surface		L/B			C_p			Use With				
Windward Wall		All values			0.8			q_z				
Leeward Wall		0-1			-0.5			q_h				
		2			-0.3							
		≥ 4			-0.2							
Side Wall		All values			-0.7			q_h				
Roof Pressure Coefficients, C_p, for use with q_h												
Wind Direction	Windward									Leeward		
	Angle, θ (degrees)										Angle, θ (degrees)	
	h/L	10	15	20	25	30	35	45	$\geq 60^\#$	10	15	≥ 20
Normal to ridge for $\theta \geq 10^\circ$	≤ 0.25	-0.7 -0.18	-0.5 0.0*	-0.3 0.2	-0.2 0.3	-0.2 0.3	0.0* 0.4	0.4	0.01 θ	-0.3	-0.5	-0.6
	0.5	-0.9 -0.18	-0.7 -0.18	-0.4 0.0*	-0.3 0.2	-0.2 0.2	-0.2 0.3	0.0* 0.4	0.01 θ	-0.5	-0.5	-0.6
	≥ 1.0	-1.3** -0.18	-1.0 -0.18	-0.7 -0.18	-0.5 0.0*	-0.3 0.2	-0.2 0.2	0.0* 0.3	0.01 θ	-0.7	-0.6	-0.6
Normal to ridge for $\theta < 10^\circ$ and Parallel to ridge for all θ	≤ 0.5	Horiz distance from windward edge			C_p		*Value is provided for interpolation purposes. **Value can be reduced linearly with area over which it is applicable as follows					
		0 to h/2			-0.9, -0.18							
		h/2 to h			-0.9, -0.18							
		h to 2 h			-0.5, -0.18							
	≥ 1.0	> 2h			-0.3, -0.18		Area (sq ft)		Reduction Factor			
		0 to h/2			-1.3**, -0.18		≤ 100 (9.3 sq m)		1.0			
> h/2			-0.7, -0.18		200 (23.2 sq m)		0.9					
					≥ 1000 (92.9 sq m)		0.8					
Notes:												
1. Plus and minus signs signify pressures acting toward and away from the surfaces, respectively.												
2. Linear interpolation is permitted for values of L/B, h/L and θ other than shown. Interpolation shall only be carried out between values of the same sign. Where no value of the same sign is given, assume 0.0 for interpolation purposes.												
3. Where two values of C_p are listed, this indicates that the windward roof slope is subjected to either positive or negative pressures and the roof structure shall be designed for both conditions. Interpolation for intermediate ratios of h/L in this case shall only be carried out between C_p values of like sign.												
4. For monoslope roofs, entire roof surface is either a windward or leeward surface.												
5. For flexible buildings use appropriate G_f as determined by Section 6.5.8.												
6. Refer to Figure 6-7 for domes and Figure 6-8 for arched roofs.												
7. Notation:												
B: Horizontal dimension of building, in feet (meter), measured normal to wind direction.												
L: Horizontal dimension of building, in feet (meter), measured parallel to wind direction.												
h: Mean roof height in feet (meters), except that eave height shall be used for $\theta \leq 10$ degrees.												
z: Height above ground, in feet (meters).												
G: Gust effect factor.												
q_z, q_h : Velocity pressure, in pounds per square foot (N/m^2), evaluated at respective height.												
θ : Angle of plane of roof from horizontal, in degrees.												
8. For mansard roofs, the top horizontal surface and leeward inclined surface shall be treated as leeward surfaces from the table.												
9. Except for MWFRS's at the roof consisting of moment resisting frames, the total horizontal shear shall not be less than that determined by neglecting wind forces on roof surfaces.												
#For roof slopes greater than 80° , use $C_p = 0.8$												

Main Wind Force Resisting System – Method 2		All Heights
Figure 6-7	External Pressure Coefficients, C_p	Domed Roofs
Enclosed, Partially Enclosed Buildings and Structures		

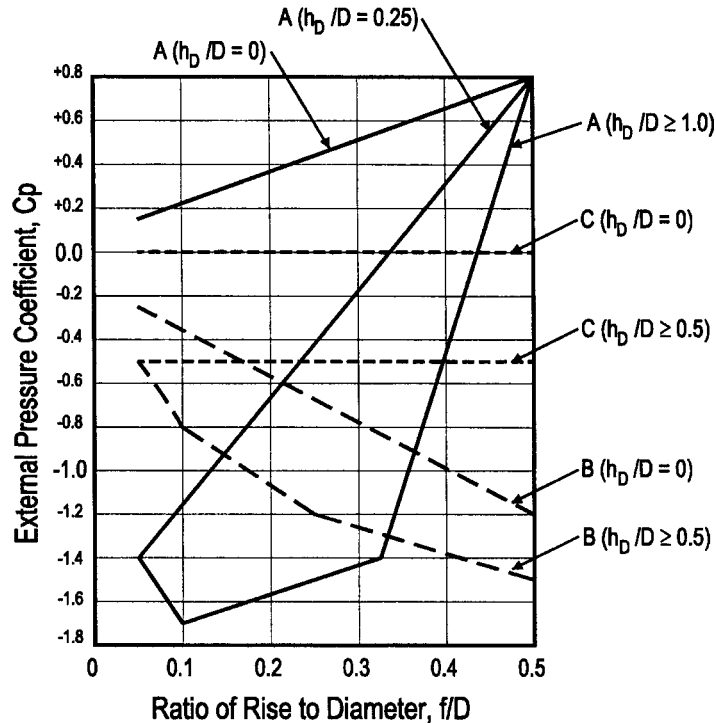
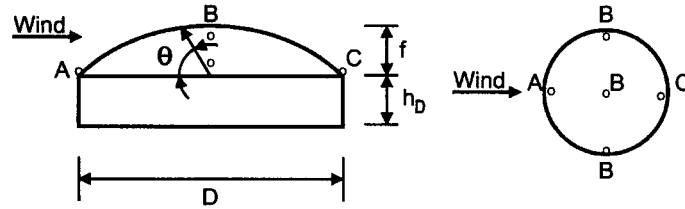

External Pressure Coefficients for Domes with a Circular Base.

(Adapted from Eurocode, 1995)

Notes:

- Two load cases shall be considered:
 - Case A. C_p values between A and B and between B and C shall be determined by linear interpolation along arcs on the dome parallel to the wind direction;
 - Case B. C_p shall be the constant value of A for $\theta \leq 25$ degrees, and shall be determined by linear interpolation from 25 degrees to B and from B to C.
- Values denote C_p to be used with $q_{(h_D+f)}$ where $h_D + f$ is the height at the top of the dome.
- Plus and minus signs signify pressures acting toward and away from the surfaces, respectively.
- C_p is constant on the dome surface for arcs of circles perpendicular to the wind direction; for example, the arc passing through B-B-B and all arcs parallel to B-B-B.
- For values of h_D/D between those listed on the graph curves, linear interpolation shall be permitted.
- $\theta = 0$ degrees on dome springline, $\theta = 90$ degrees at dome center top point. f is measured from springline to top.
- The total horizontal shear shall not be less than that determined by neglecting wind forces on roof surfaces.
- For f/D values less than 0.05, use Figure 6-6.

Main Wind Force Res. Sys. / Comp and Clad. – Method 2		All Heights
Figure 6-8	External Pressure Coefficients, C_p	Arched Roofs
Enclosed, Partially Enclosed Buildings and Structures		

Conditions	Rise-to-span ratio, r	C_p		
		Windward quarter	Center half	Leeward quarter
Roof on elevated structure	$0 < r < 0.2$	-0.9	$-0.7 - r$	-0.5
	$0.2 \leq r < 0.3^*$	$1.5r - 0.3$	$-0.7 - r$	-0.5
	$0.3 \leq r \leq 0.6$	$2.75r - 0.7$	$-0.7 - r$	-0.5
Roof springing from ground level	$0 < r \leq 0.6$	$1.4r$	$-0.7 - r$	-0.5

*When the rise-to-span ratio is $0.2 \leq r \leq 0.3$, alternate coefficients given by 6r - 2.1 shall also be used for the windward quarter.

Notes:

1. Values listed are for the determination of average loads on main wind force resisting systems.
2. Plus and minus signs signify pressures acting toward and away from the surfaces, respectively.
3. For wind directed parallel to the axis of the arch, use pressure coefficients from Fig. 6-6 with wind directed parallel to ridge.
4. For components and cladding: (1) At roof perimeter, use the external pressure coefficients in Fig. 6-11 with θ based on spring-line slope and (2) for remaining roof areas, use external pressure coefficients of this table multiplied by 0.87.

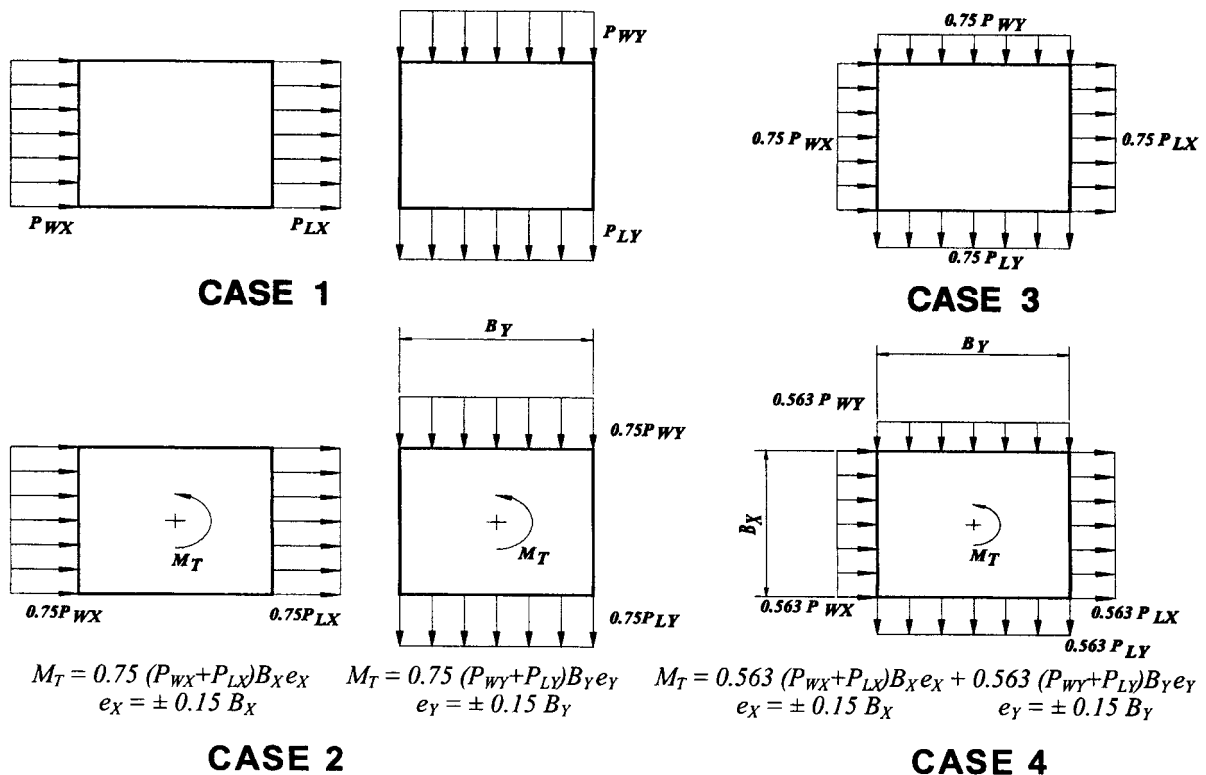

Case 1. Full design wind pressure acting on the projected area perpendicular to each principal axis of the structure, considered separately along each principal axis.

Case 2. Three quarters of the design wind pressure acting on the projected area perpendicular to each principal axis of the structure in conjunction with a torsional moment as shown, considered separately for each principal axis.

Case 3. Wind loading as defined in Case 1, but considered to act simultaneously at 75% of the specified value.

Case 4. Wind loading as defined in Case 2, but considered to act simultaneously at 75% of the specified value.

Notes:

- Design wind pressures for windward and leeward faces shall be determined in accordance with the provisions of 6.5.12.2.1 and 6.5.12.2.3 as applicable for building of all heights.
- Diagrams show plan views of building.
- Notation:

P_{WX}, P_{WY} : Windward face design pressure acting in the x, y principal axis, respectively.

P_{LX}, P_{LY} : Leeward face design pressure acting in the x, y principal axis, respectively.

$e (e_X, e_Y)$: Eccentricity for the x, y principal axis of the structure, respectively.

M_T : Torsional moment per unit height acting about a vertical axis of the building.

Main Wind Force Resisting System – Method 2		$h \leq 60$ ft.
Figure 6-10	External Pressure Coefficients, $G C_{pf}$	Low-rise Walls & Roofs
Enclosed, Partially Enclosed Buildings		

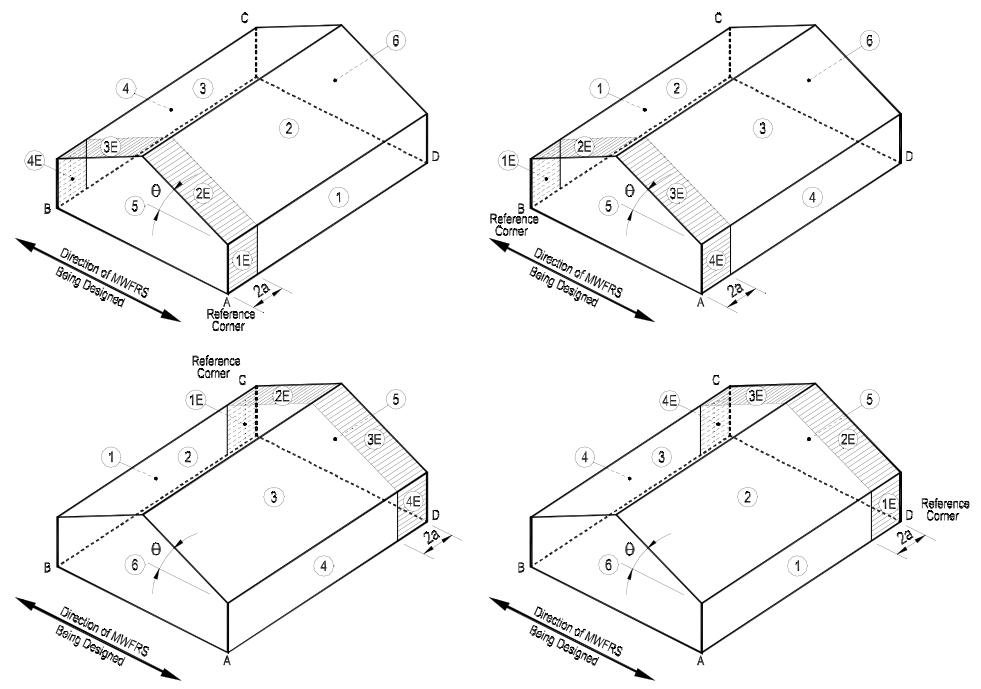

Transverse Direction

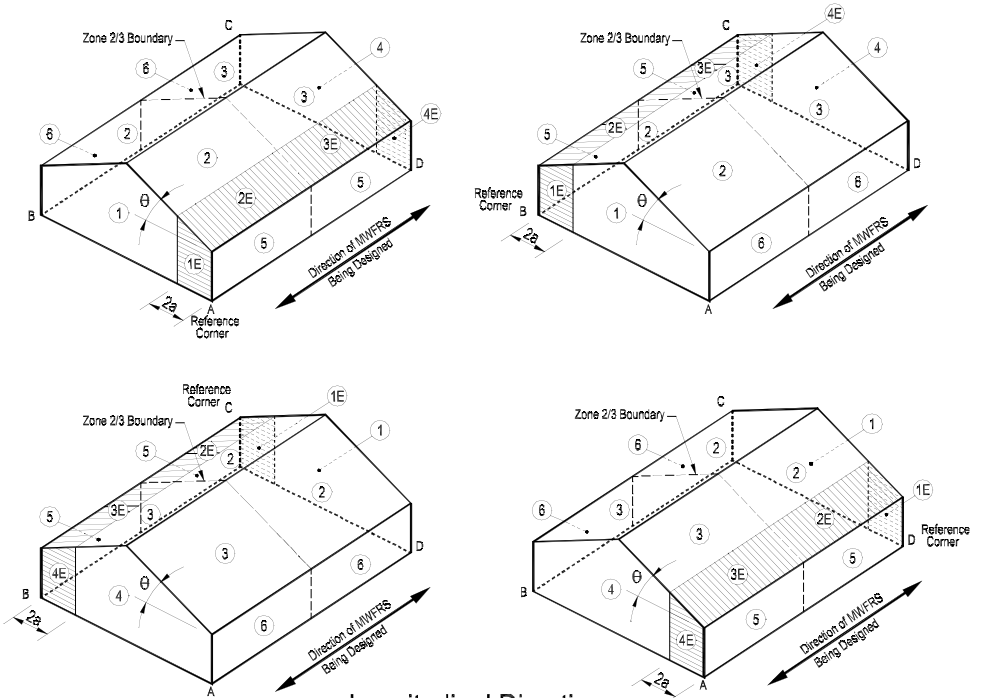

Longitudinal Direction

Basic Load Cases

Main Wind Force Resisting System – Method 2		$h \leq 60$ ft.
Figure 6-10 (cont'd)	External Pressure Coefficients, GC_{pf}	Low-rise Walls & Roofs
Enclosed, Partially Enclosed Buildings		

Roof Angle θ (degrees)	Building Surface									
	1	2	3	4	5	6	1E	2E	3E	4E
0-5	0.40	-0.69	-0.37	-0.29	-0.45	-0.45	0.61	-1.07	-0.53	-0.43
20	0.53	-0.69	-0.48	-0.43	-0.45	-0.45	0.80	-1.07	-0.69	-0.64
30-45	0.56	0.21	-0.43	-0.37	-0.45	-0.45	0.69	0.27	-0.53	-0.48
90	0.56	0.56	-0.37	-0.37	-0.45	-0.45	0.69	0.69	-0.48	-0.48

Notes:

1. Plus and minus signs signify pressures acting toward and away from the surfaces, respectively.
2. For values of θ other than those shown, linear interpolation is permitted.
3. The building must be designed for all wind directions using the 8 loading patterns shown. The load patterns are applied to each building corner in turn as the Reference Corner.
4. Combinations of external and internal pressures (see Figure 6-5) shall be evaluated as required to obtain the most severe loadings.
5. For the torsional load cases shown below, the pressures in zones designated with a "T" (1T, 2T, 3T, 4T) shall be 25% of the full design wind pressures (zones 1, 2, 3, 4).
 Exception: One story buildings with h less than or equal to 30 ft (9.1m), buildings two stories or less framed with light frame construction, and buildings two stories or less designed with flexible diaphragms need not be designed for the torsional load cases.
 Torsional loading shall apply to all eight basic load patterns using the figures below applied at each reference corner.
6. Except for moment-resisting frames, the total horizontal shear shall not be less than that determined by neglecting wind forces on roof surfaces.
7. For the design of the MWFRS providing lateral resistance in a direction parallel to a ridge line or for flat roofs, use $\theta = 0^\circ$ and locate the zone 2/3 boundary at the mid-length of the building.
8. The roof pressure coefficient GC_{pf} , when negative in Zone 2 or 2E, shall be applied in Zone 2/2E for a distance from the edge of roof equal to 0.5 times the horizontal dimension of the building parallel to the direction of the MWFRS being designed or 2.5 times the eave height, h_e , at the windward wall, whichever is less; the remainder of Zone 2/2E extending to the ridge line shall use the pressure coefficient GC_{pf} for Zone 3/3E.
9. Notation:
 a : 10 percent of least horizontal dimension or 0.4h, whichever is smaller, but not less than either 4% of least horizontal dimension or 3 ft (0.9 m).
 h : Mean roof height, in feet (meters), except that eave height shall be used for $\theta \leq 10^\circ$.
 θ : Angle of plane of roof from horizontal, in degrees.

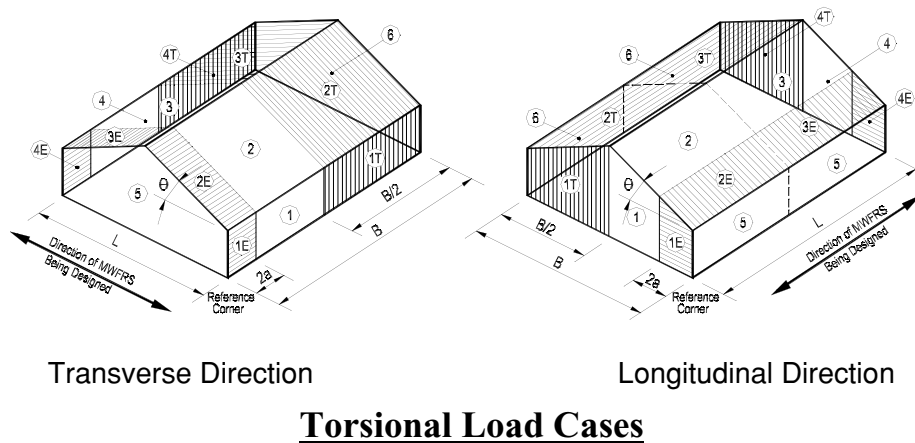

Components and Cladding – Method 2		$h \leq 60$ ft.
Figure 6-11A	External Pressure Coefficients, GC_p	Walls
Enclosed, Partially Enclosed Buildings		

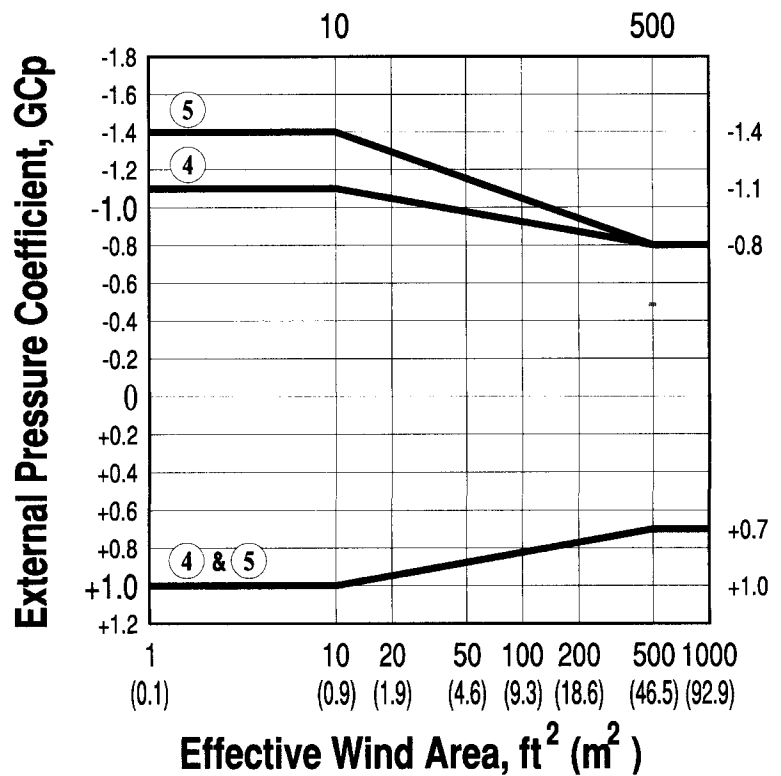
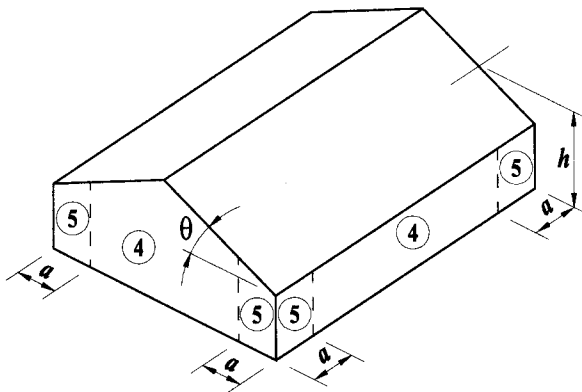

Notes:

- Vertical scale denotes GC_p to be used with q_h .
- Horizontal scale denotes effective wind area, in square feet (square meters).
- Plus and minus signs signify pressures acting toward and away from the surfaces, respectively.
- Each component shall be designed for maximum positive and negative pressures.
- Values of GC_p for walls shall be reduced by 10% when $\theta \leq 10^\circ$.
- Notation:
 - a : 10 percent of least horizontal dimension or $0.4h$, whichever is smaller, but not less than either 4% of least horizontal dimension or 3 ft (0.9 m).
 - h : Mean roof height, in feet (meters), except that eave height shall be used for $\theta \leq 10^\circ$.
 - θ : Angle of plane of roof from horizontal, in degrees.

Figure 6-11B

External Pressure Coefficients, GC_p

Enclosed, Partially Enclosed Buildings

Gable Roofs $\theta \leq 7^\circ$

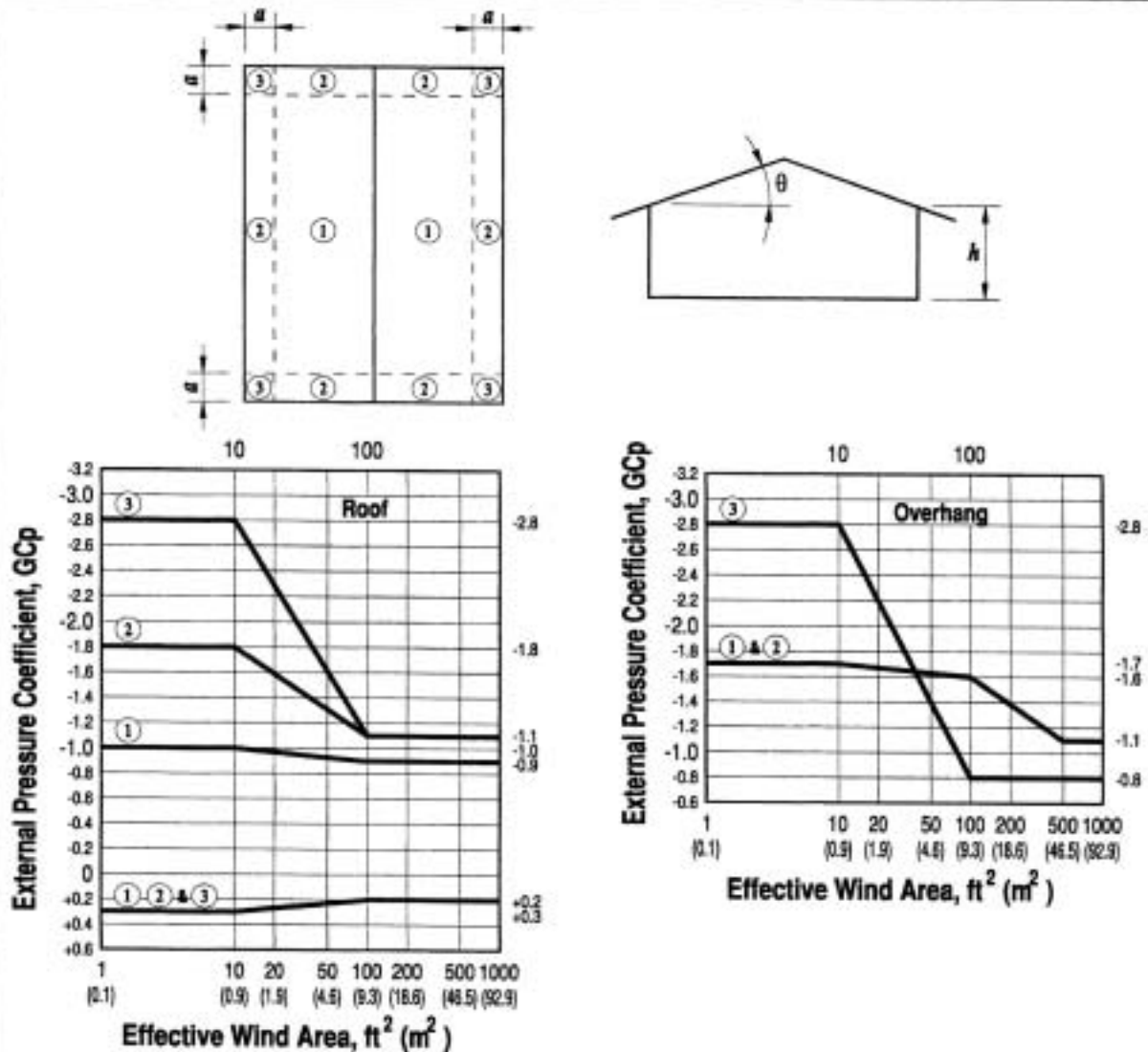

Notes:

1. Vertical scale denotes GC_p to be used with q_p .
2. Horizontal scale denotes effective wind area, in square feet (square meters).
3. Plus and minus signs signify pressures acting toward and away from the surfaces, respectively.
4. Each component shall be designed for maximum positive and negative pressures.
5. If a parapet equal to or higher than 3 ft (0.9m) is provided around the perimeter of the roof with $\theta \leq 7^\circ$, the negative values of GC_p in Zone 3 shall be equal to those for Zone 2 and positive values of GC_p in Zones 2 and 4 shall be set equal to those for wall Zones 4 and 5 respectively in Figure 6-11A.
6. Values of GC_p for roof overhangs include pressure contributions from both upper and lower surfaces.
7. Notation:
 - a : 10 percent of least horizontal dimension or $0.4h$, whichever is smaller, but not less than either 4% of least horizontal dimension or 3 ft (0.9 m).
 - h : Eave height shall be used for $\theta \leq 10^\circ$.
 - θ : Angle of plane of roof from horizontal, in degrees.

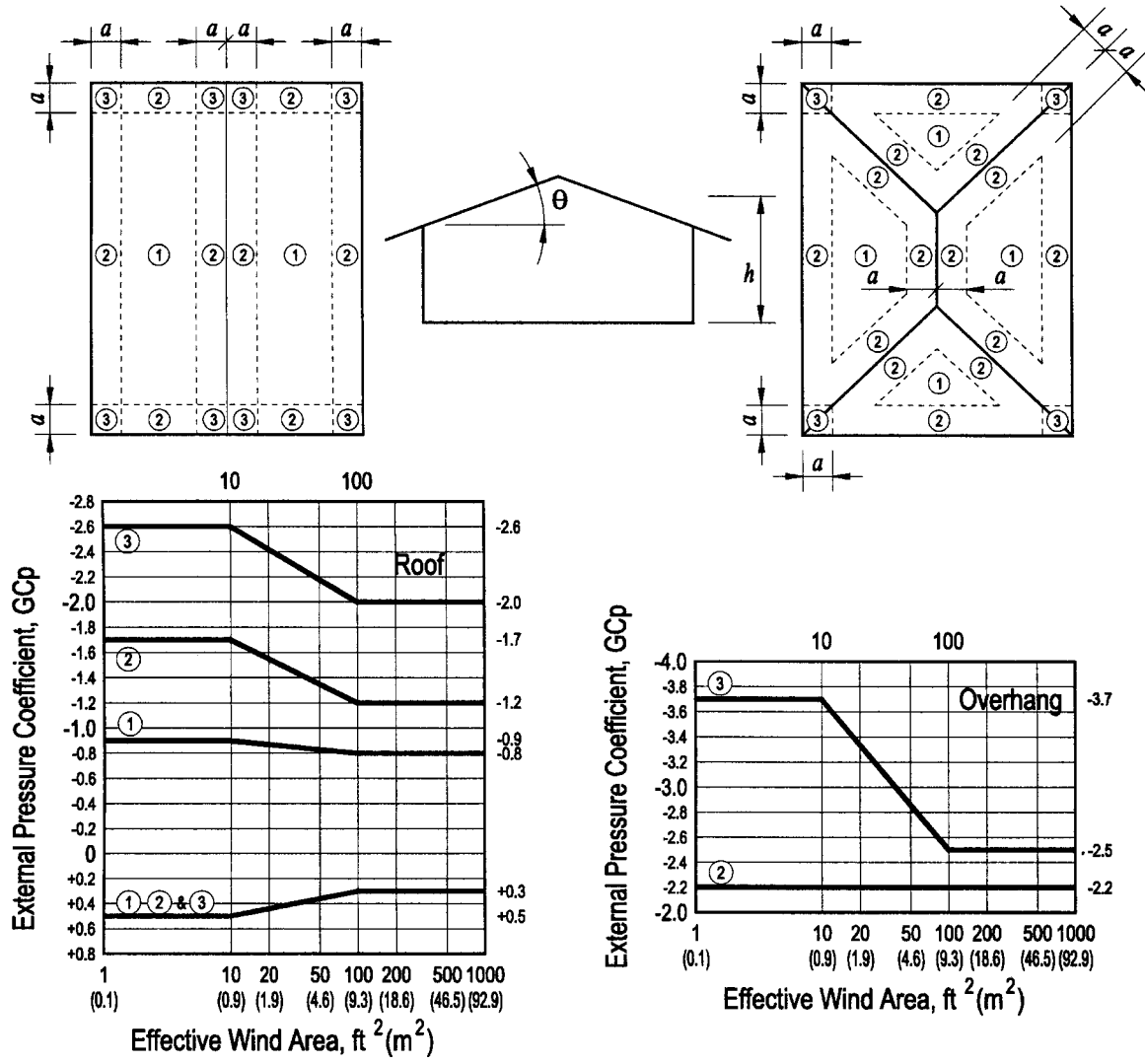

- Notes:**
- Vertical scale denotes GC_p to be used with q_h .
 - Horizontal scale denotes effective wind area, in square feet (square meters).
 - Plus and minus signs signify pressures acting toward and away from the surfaces, respectively.
 - Each component shall be designed for maximum positive and negative pressures.
 - Values of GC_p for roof overhangs include pressure contributions from both upper and lower surfaces.
 - For hip roofs with $7^\circ < \theta \leq 27^\circ$, edge/ridge strips and pressure coefficients for ridges of gabled roofs shall apply on each hip.
 - For hip roofs with $\theta \leq 25^\circ$, Zone 3 shall be treated as Zone 2.
 - Notation:
 - a : 10 percent of least horizontal dimension or $0.4h$, whichever is smaller, but not less than either 4% of least horizontal dimension or 3 ft (0.9 m).
 - h : Mean roof height, in feet (meters), except that eave height shall be used for $\theta \leq 10^\circ$.
 - θ : Angle of plane of roof from horizontal, in degrees.

Figure 6-11D

External Pressure Coefficients GC_p

Gable Roofs $27^\circ < \theta \leq 45^\circ$

Enclosed, Partially Enclosed Buildings

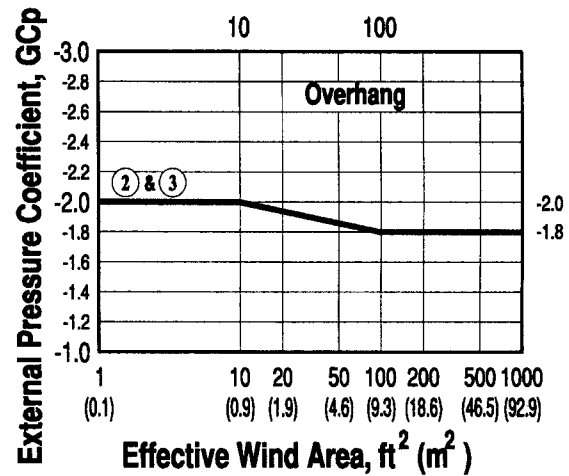
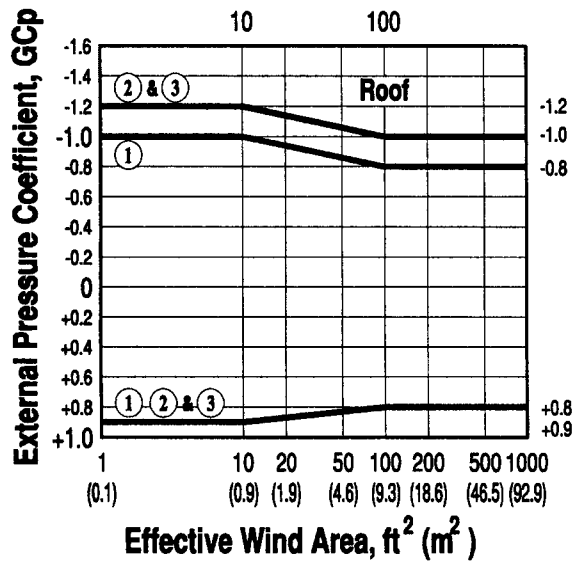
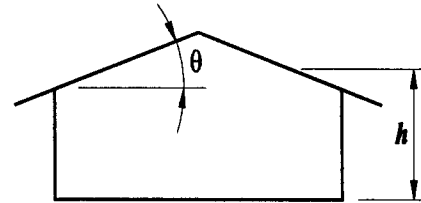
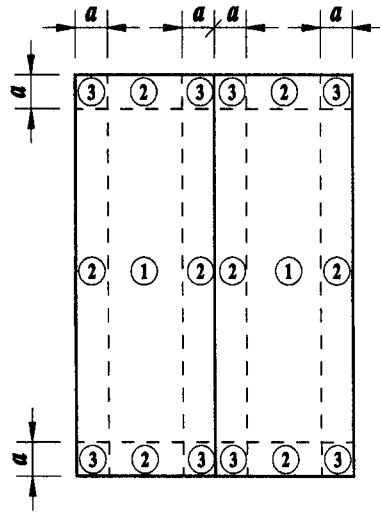

Notes:

- Vertical scale denotes GC_p to be used with q_h .
- Horizontal scale denotes effective wind area, in square feet (square meters).
- Plus and minus signs signify pressures acting toward and away from the surfaces, respectively.
- Each component shall be designed for maximum positive and negative pressures.
- Values of GC_p for roof overhangs include pressure contributions from both upper and lower surfaces.
- Notation:
 - a : 10 percent of least horizontal dimension or $0.4h$, whichever is smaller, but not less than either 4% of least horizontal dimension or 3 ft (0.9 m).
 - h : Mean roof height, in feet (meters).
 - θ : Angle of plane of roof from horizontal, in degrees.

Figure 6-12

External Pressure Coefficients, GC_p

Enclosed, Partially Enclosed Buildings

Stepped Roofs

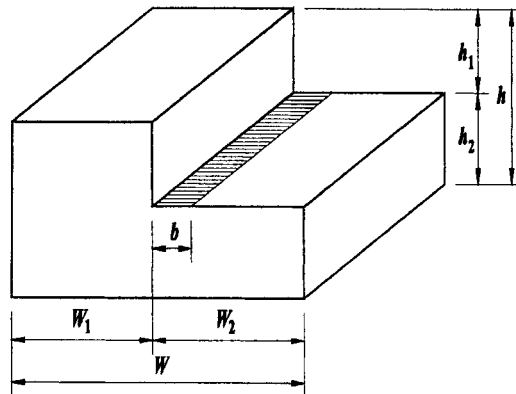

$$h_1 \geq 10 \text{ ft. (3 m)}$$

$$b = 1.5 h_1$$

$$b < 100 \text{ ft. (30.5 m)}$$

$$\frac{h_i}{h} = 0.3 \text{ to } 0.7$$

$$\frac{W_i}{W} = 0.25 \text{ to } 0.75$$

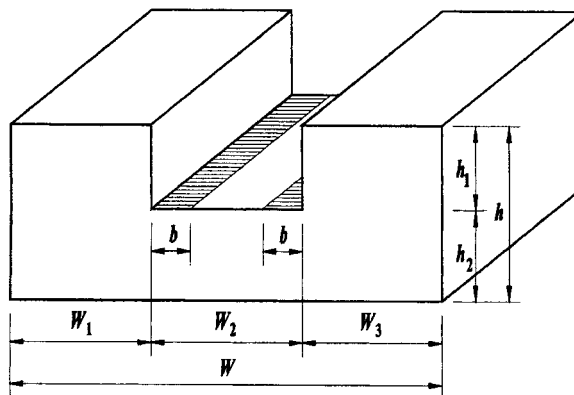

Notes:

- On the lower level of flat, stepped roofs shown in Fig. 6-12, the zone designations and pressure coefficients shown in Fig. 6-11B shall apply, except that at the roof-upper wall intersection(s), Zone 3 shall be treated as Zone 2 and Zone 2 shall be treated as Zone 1. Positive values of GC_p equal to those for walls in Fig. 6-11A shall apply on the cross-hatched areas shown in Fig. 6-12.
- Notation:
 - b : $1.5h_1$ in Fig. 6-12, but not greater than 100 ft (30.5 m).
 - h : Mean roof height, in feet (meters).
 - h_i : h_1 or h_2 in Fig. 6-12; $h = h_1 + h_2$; $h_1 \geq 10$ ft (3.1 m); $h_i/h = 0.3$ to 0.7.
 - W : Building width in Fig. 6-12.
 - W_i : W_1 or W_2 or W_3 in Fig. 6-12. $W = W_1 + W_2$ or $W_1 + W_2 + W_3$; $W_i/W = 0.25$ to 0.75.
 - θ : Angle of plane of roof from horizontal, in degrees.

Figure 6-13

External Pressure Coefficients, GC_p

Enclosed, Partially Enclosed Buildings

Multispan Gable Roofs

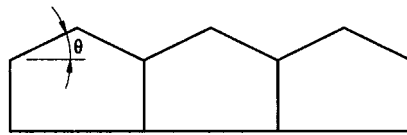

ELEVATION OF BUILDING
(2 or More Spans)

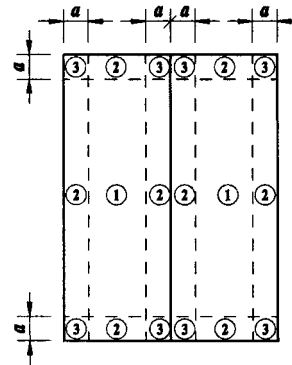

PLAN AND ELEVATION OF
A SINGLE SPAN MODULE

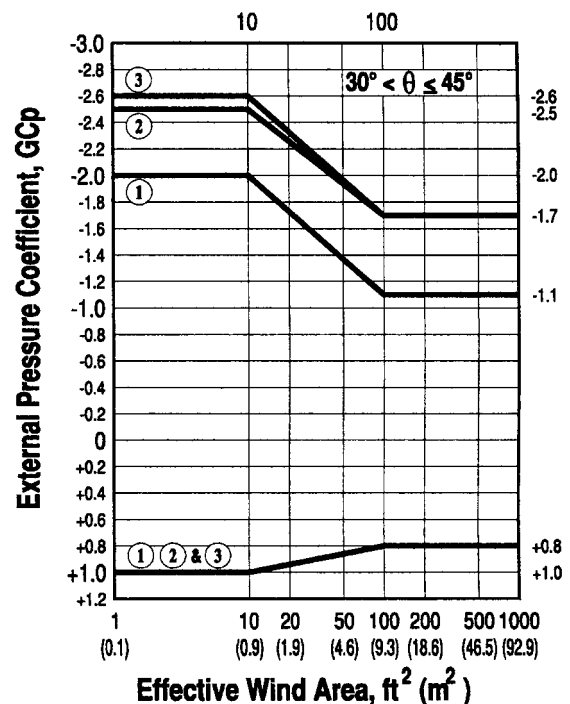
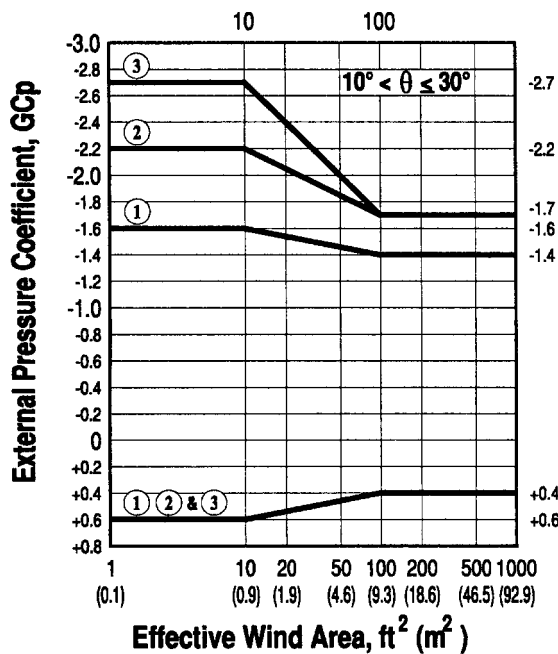

Notes:

1. Vertical scale denotes GC_p to be used with q_h .
2. Horizontal scale denotes effective wind area A , in square feet (square meters).
3. Plus and minus signs signify pressures acting toward and away from the surfaces, respectively.
4. Each component shall be designed for maximum positive and negative pressures.
5. For $\theta \leq 10^\circ$, values of GC_p from Fig. 6-11 shall be used.
6. Notation:
 - a : 10 percent of least horizontal dimension of a single-span module or $0.4h$, whichever is smaller, but not less than either 4 percent of least horizontal dimension of a single-span module or 3 ft (0.9 m).
 - h : Mean roof height, in feet (meters), except that eave height shall be used for $\theta \leq 10^\circ$.
 - W : Building module width, in feet (meters).
 - θ : Angle of plane of roof from horizontal, in degrees.

Components and Cladding – Method 2		$h \leq 60$ ft.
Figure 6-14A	External Pressure Coefficients, GC_p	Monoslope Roofs
Enclosed, Partially Enclosed Buildings		$3^\circ < \theta \leq 10^\circ$

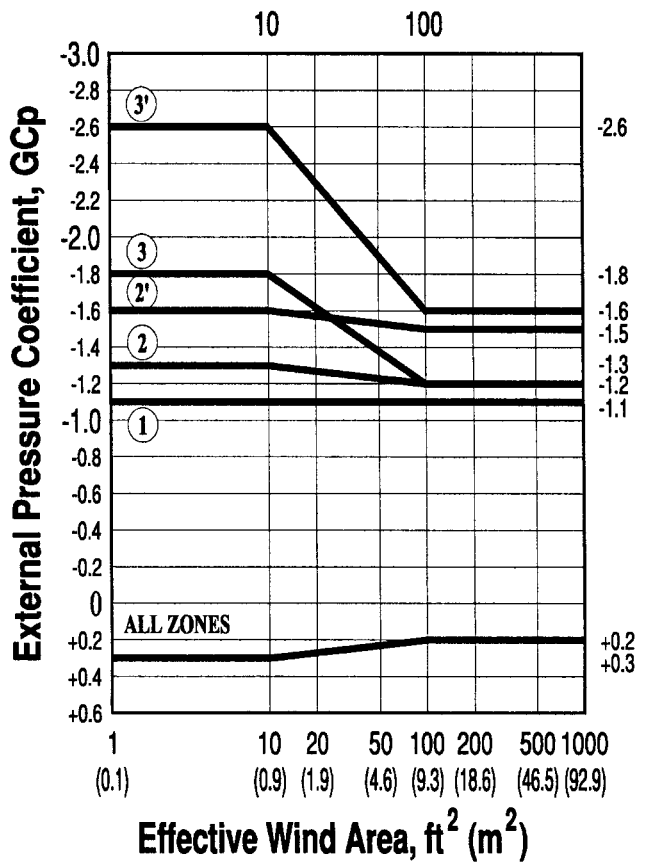
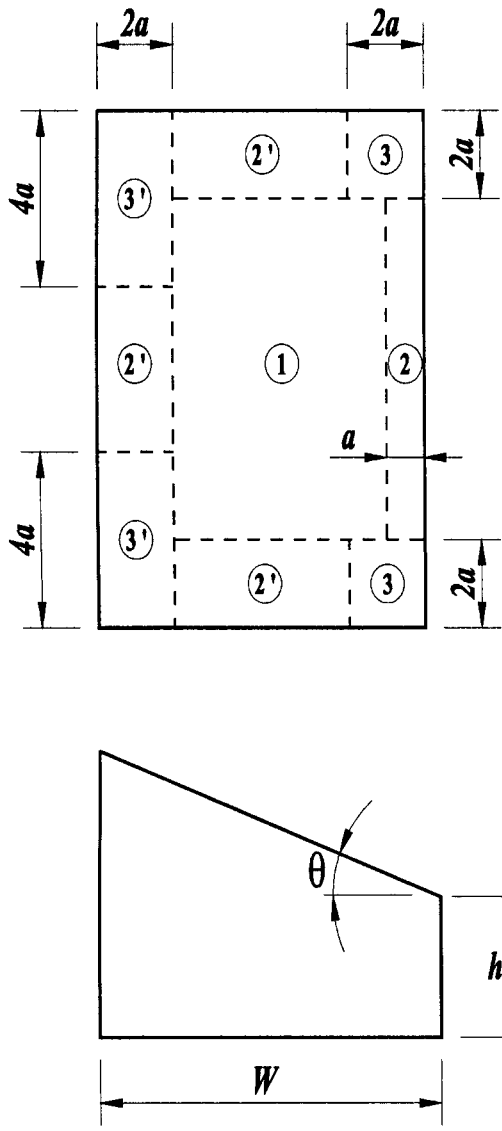

Notes:

- Vertical scale denotes GC_p to be used with q_h .
- Horizontal scale denotes effective wind area A , in square feet (square meters).
- Plus and minus signs signify pressures acting toward and away from the surfaces, respectively.
- Each component shall be designed for maximum positive and negative pressures.
- For $\theta \leq 3^\circ$, values of GC_p from Fig. 6-11B shall be used.
- Notation:
 - a : 10 percent of least horizontal dimension or $0.4h$, whichever is smaller, but not less than either 4 percent of least horizontal dimension or 3 ft (0.9 m).
 - h : Eave height shall be used for $\theta \leq 10^\circ$.
 - W : Building width, in feet (meters).
 - θ : Angle of plane of roof from horizontal, in degrees.

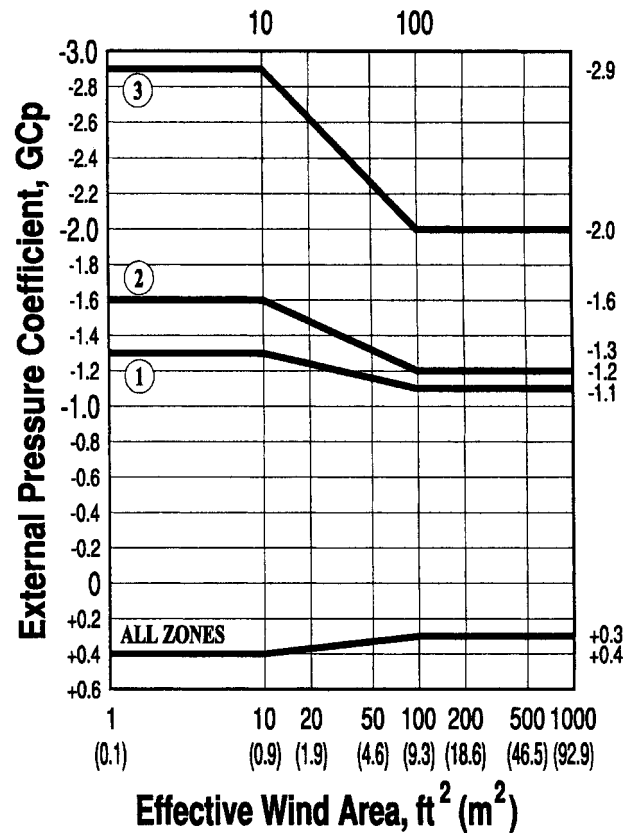
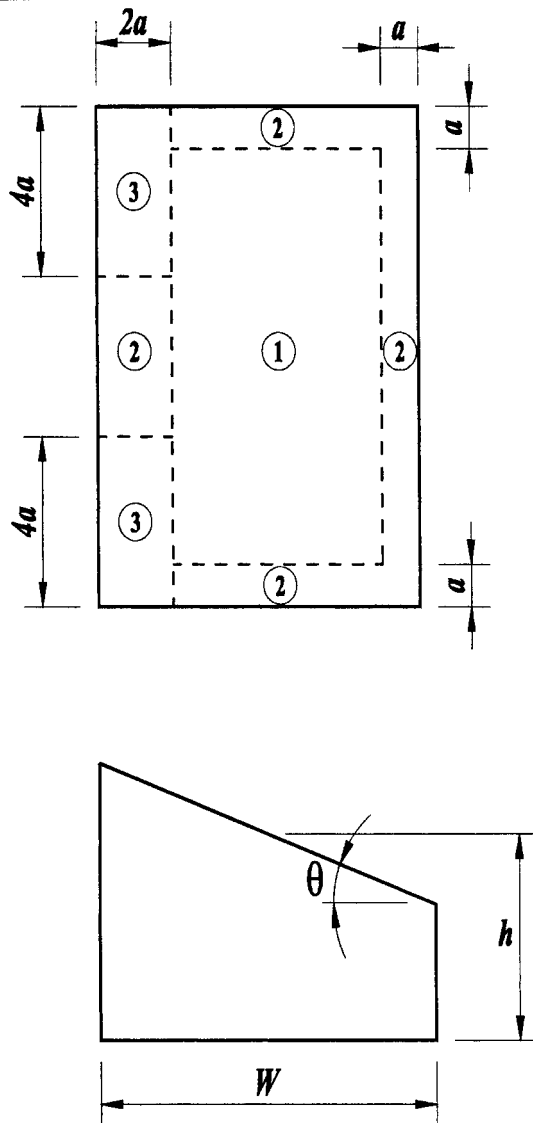

Notes:

1. Vertical scale denotes GC_p to be used with q_h .
2. Horizontal scale denotes effective wind area A , in square feet (square meters).
3. Plus and minus signs signify pressures acting toward and away from the surfaces, respectively.
4. Each component shall be designed for maximum positive and negative pressures.
5. Notation:
 - a : 10 percent of least horizontal dimension or $0.4h$, whichever is smaller, but not less than either 4 percent of least horizontal dimension or 3 ft (0.9 m).
 - h : Mean roof height, in feet (meters).
 - W : Building width, in feet (meters).
 - θ : Angle of plane of roof from horizontal, in degrees.

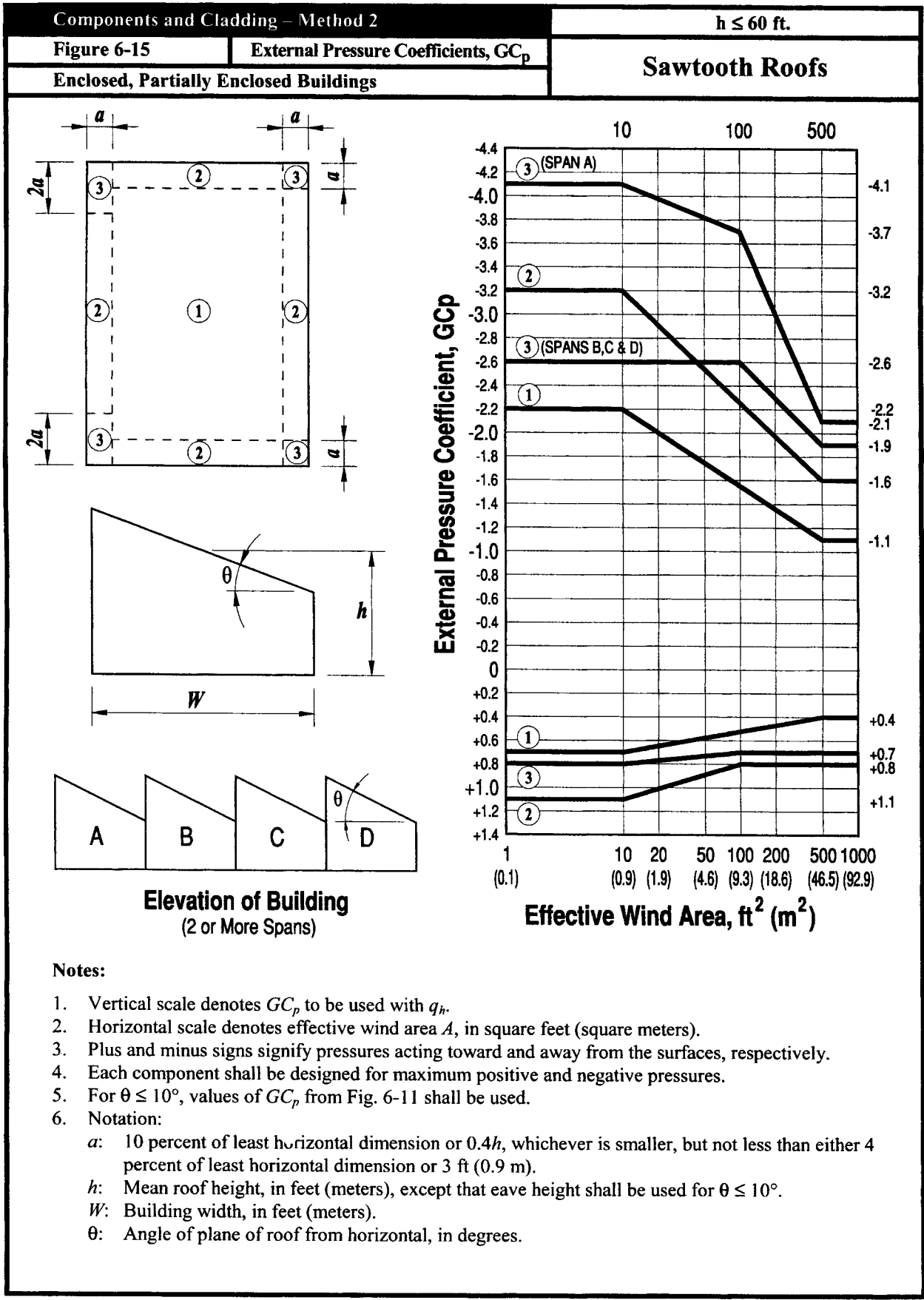

Components and Cladding – Method 2		All Heights
Figure 6-16	External Pressure Coefficients, GC_p	Domed Roofs
Enclosed, Partially Enclosed Buildings and Structures		

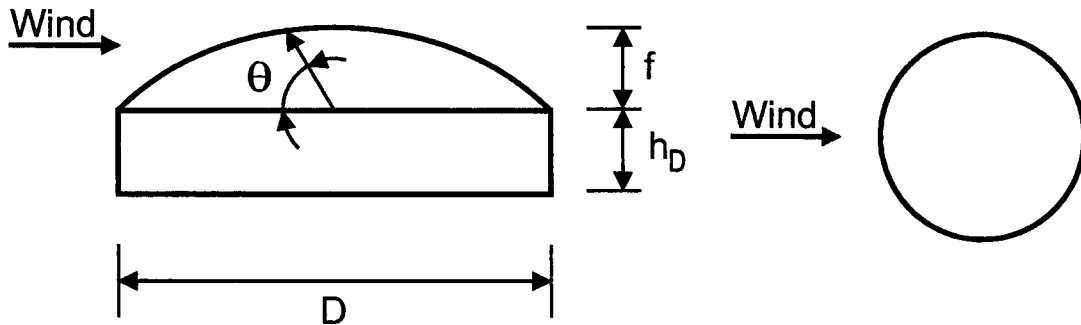

External Pressure Coefficients for Domes with a Circular Base			
	Negative Pressures	Positive Pressures	Positive Pressures
θ , degrees	0 – 90	0 – 60	61 – 90
GC_p	-0.9	+0.9	+0.5

Notes:

1. Values denote GC_p to be used with $q_{(h_D+f)}$ where $h_D + f$ is the height at the top of the dome.
2. Plus and minus signs signify pressures acting toward and away from the surfaces, respectively.
3. Each component shall be designed for the maximum positive and negative pressures.
4. Values apply to $0 \leq h_D/D \leq 0.5$, $0.2 \leq f/D \leq 0.5$.
5. $\theta = 0$ degrees on dome springline, $\theta = 90$ degrees at dome center top point. f is measured from springline to top.

Figure 6-17

External Pressure Coefficients, GC_p

Walls & Roofs

Enclosed, Partially Enclosed Buildings

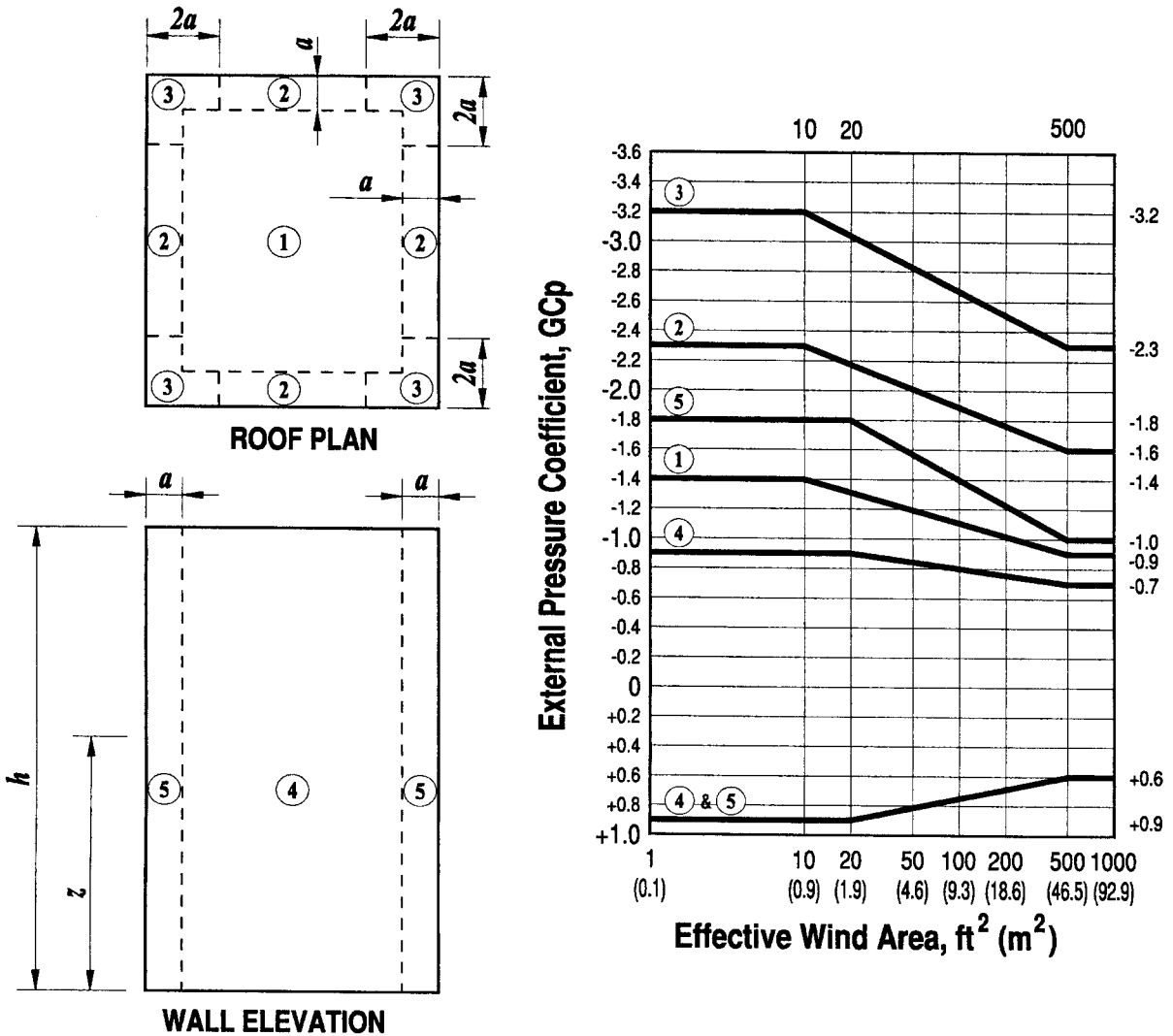

Notes:

1. Vertical scale denotes GC_p to be used with appropriate q_z or q_h .
2. Horizontal scale denotes effective wind area A , in square feet (square meters).
3. Plus and minus signs signify pressures acting toward and away from the surfaces, respectively.
4. Use q_z with positive values of GC_p and q_h with negative values of GC_p .
5. Each component shall be designed for maximum positive and negative pressures.
6. Coefficients are for roofs with angle $\theta \leq 10^\circ$. For other roof angles and geometry, use GC_p values from Fig. 6-11 and attendant q_h based on exposure defined in 6.5.6.
7. If a parapet equal to or higher than 3 ft (0.9m) is provided around the perimeter of the roof with $\theta \leq 10^\circ$, Zone 3 shall be treated as Zone 2.
8. Notation:
 - a : 10 percent of least horizontal dimension, but not less than 3 ft (0.9 m).
 - h : Mean roof height, in feet (meters), except that eave height shall be used for $\theta \leq 10^\circ$.
 - z : height above ground, in feet (meters).
 - θ : Angle of plane of roof from horizontal, in degrees.

Main Wind Force Resisting System		$0.25 \leq h/L \leq 1.0$
Figure 6-18A	Net Pressure Coefficient, C_N	Monoslope Free Roofs $q \leq 45^\circ, \gamma = 0^\circ, 180^\circ$
Open Buildings		

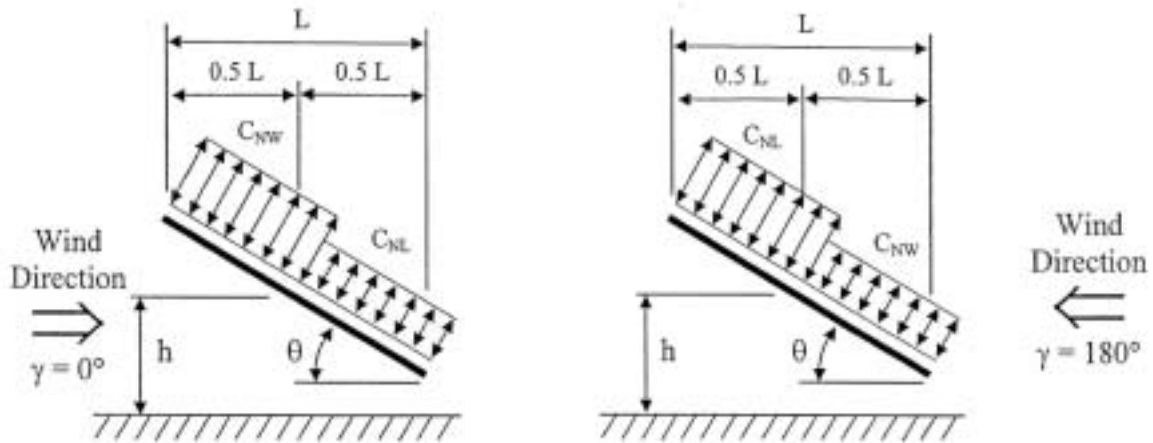

Roof Angle θ	Load Case	Wind Direction, $\gamma = 0^\circ$				Wind Direction, $\gamma = 180^\circ$			
		Clear Wind Flow		Obstructed Wind Flow		Clear Wind Flow		Obstructed Wind Flow	
		C_{NW}	C_{NL}	C_{NW}	C_{NL}	C_{NW}	C_{NL}	C_{NW}	C_{NL}
0°	A	1.2	0.3	-0.5	-1.2	1.2	0.3	-0.5	-1.2
	B	-1.1	-0.1	-1.1	-0.6	-1.1	-0.1	-1.1	-0.6
7.5°	A	-0.6	-1	-1	-1.5	0.9	1.5	-0.2	-1.2
	B	-1.4	0	-1.7	-0.8	1.6	0.3	0.8	-0.3
15°	A	-0.9	-1.3	-1.1	-1.5	1.3	1.6	0.4	-1.1
	B	-1.9	0	-2.1	-0.6	1.8	0.6	1.2	-0.3
22.5°	A	-1.5	-1.6	-1.5	-1.7	1.7	1.8	0.5	-1
	B	-2.4	-0.3	-2.3	-0.9	2.2	0.7	1.3	0
30°	A	-1.8	-1.8	-1.5	-1.8	2.1	2.1	0.6	-1
	B	-2.5	-0.5	-2.3	-1.1	2.6	1	1.6	0.1
37.5°	A	-1.8	-1.8	-1.5	-1.8	2.1	2.2	0.7	-0.9
	B	-2.4	-0.6	-2.2	-1.1	2.7	1.1	1.9	0.3
45°	A	-1.6	-1.8	-1.3	-1.8	2.2	2.5	0.8	-0.9
	B	-2.3	-0.7	-1.9	-1.2	2.6	1.4	2.1	0.4

Notes:

- C_{NW} and C_{NL} denote net pressures (contributions from top and bottom surfaces) for windward and leeward half of roof surfaces, respectively.
- Clear wind flow denotes relatively unobstructed wind flow with blockage less than or equal to 50%. Obstructed wind flow denotes objects below roof inhibiting wind flow (>50% blockage).
- For values of θ between 7.5° and 45° , linear interpolation is permitted. For values of θ less than 7.5° , use load coefficients for 0° .
- Plus and minus signs signify pressures acting towards and away from the top roof surface, respectively.
- All load cases shown for each roof angle shall be investigated.
- Notation:
 L : horizontal dimension of roof, measured in the along wind direction, ft. (m)
 h : mean roof height, ft. (m)
 γ : direction of wind, degrees
 θ : angle of plane of roof from horizontal, degrees

Main Wind Force Resisting System		$0.25 \leq h/L \leq 1.0$
Figure 6-18B	Net Pressure Coefficient, C_N	Pitched Free Roofs $\theta \leq 45^\circ, \gamma = 0^\circ, 180^\circ$
Open Buildings		

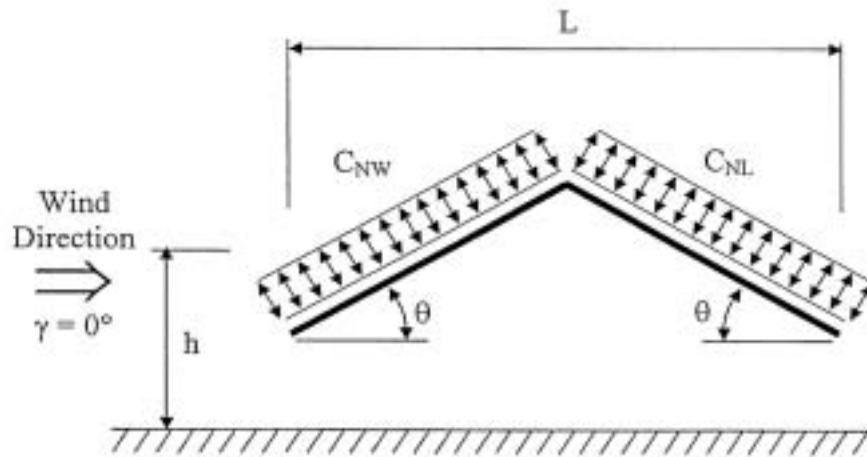

Roof Angle, θ	Load Case	Wind Direction, $g = 0^\circ, 180^\circ$			
		Clear Wind Flow		Obstructed Wind Flow	
		C_{NW}	C_{NL}	C_{NW}	C_{NL}
7.5°	A	1.1	-0.3	-1.6	-1
	B	0.2	-1.2	-0.9	-1.7
15°	A	1.1	-0.4	-1.2	-1
	B	0.1	-1.1	-0.6	-1.6
22.5°	A	1.1	0.1	-1.2	-1.2
	B	-0.1	-0.8	-0.8	-1.7
30°	A	1.3	0.3	-0.7	-0.7
	B	-0.1	-0.9	-0.2	-1.1
37.5°	A	1.3	0.6	-0.6	-0.6
	B	-0.2	-0.6	-0.3	-0.9
45°	A	1.1	0.9	-0.5	-0.5
	B	-0.3	-0.5	-0.3	-0.7

Notes:

- C_{NW} and C_{NL} denote net pressures (contributions from top and bottom surfaces) for windward and leeward half of roof surfaces, respectively.
- Clear wind flow denotes relatively unobstructed wind flow with blockage less than or equal to 50%. Obstructed wind flow denotes objects below roof inhibiting wind flow (>50% blockage).
- For values of θ between 7.5° and 45°, linear interpolation is permitted. For values of θ less than 7.5°, use monoslope roof load coefficients.
- Plus and minus signs signify pressures acting towards and away from the top roof surface, respectively.
- All load cases shown for each roof angle shall be investigated.
- Notation:
 L : horizontal dimension of roof, measured in the along wind direction, ft. (m)
 h : mean roof height, ft. (m)
 γ : direction of wind, degrees
 θ : angle of plane of roof from horizontal, degrees

Main Wind Force Resisting System		$0.25 \leq h/L \leq 1.0$
Figure 6-18C	Net Pressure Coefficient, C_N	Troughed Free Roofs $\theta \leq 45^\circ, \gamma = 0^\circ, 180^\circ$
Open Buildings		

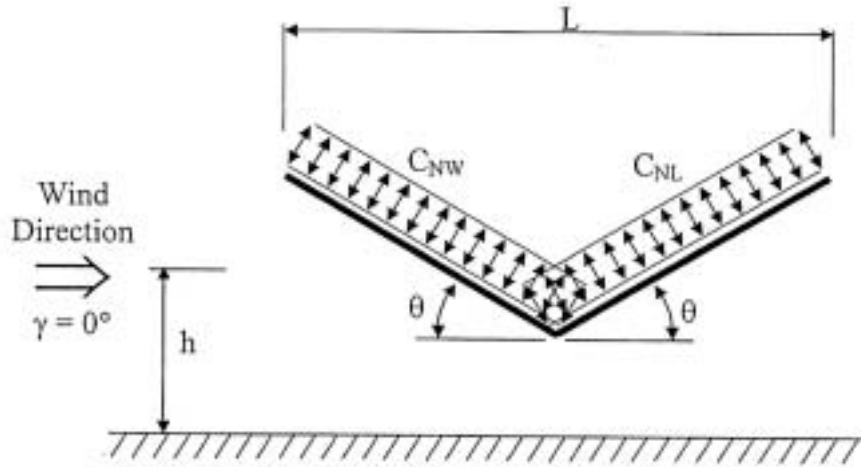

Roof Angle θ	Load Case	Wind Direction, $\gamma = 0^\circ, 180^\circ$			
		Clear Wind Flow		Obstructed Wind Flow	
		C_{NW}	C_{NL}	C_{NW}	C_{NL}
7.5°	A	-1.1	0.3	-1.6	-0.5
	B	-0.2	1.2	-0.9	-0.8
15°	A	-1.1	0.4	-1.2	-0.5
	B	0.1	1.1	-0.6	-0.8
22.5°	A	-1.1	-0.1	-1.2	-0.6
	B	-0.1	0.8	-0.8	-0.8
30°	A	-1.3	-0.3	-1.4	-0.4
	B	-0.1	0.9	-0.2	-0.5
37.5°	A	-1.3	-0.6	-1.4	-0.3
	B	0.2	0.6	-0.3	-0.4
45°	A	-1.1	-0.9	-1.2	-0.3
	B	0.3	0.5	-0.3	-0.4

Notes:

- C_{NW} and C_{NL} denote net pressures (contributions from top and bottom surfaces) for windward and leeward half of roof surfaces, respectively.
- Clear wind flow denotes relatively unobstructed wind flow with blockage less than or equal to 50%. Obstructed wind flow denotes objects below roof inhibiting wind flow (>50% blockage).
- For values of θ between 7.5° and 45°, linear interpolation is permitted. For values of θ less than 7.5°, use monoslope roof load coefficients.
- Plus and minus signs signify pressures acting towards and away from the top roof surface, respectively.
- All load cases shown for each roof angle shall be investigated.
- Notation:
 - L : horizontal dimension of roof, measured in the along wind direction, ft. (m)
 - h : mean roof height, ft. (m)
 - γ : direction of wind, degrees
 - θ : angle of plane of roof from horizontal, degrees

Main Wind Force Resisting System		$0.25 \leq h/L \leq 1.0$
Figure 6-18D	Net Pressure Coefficient, C_N	Troughed Free Roofs $\theta \leq 45^\circ, \lambda = 0^\circ, 180^\circ$
Open Buildings		

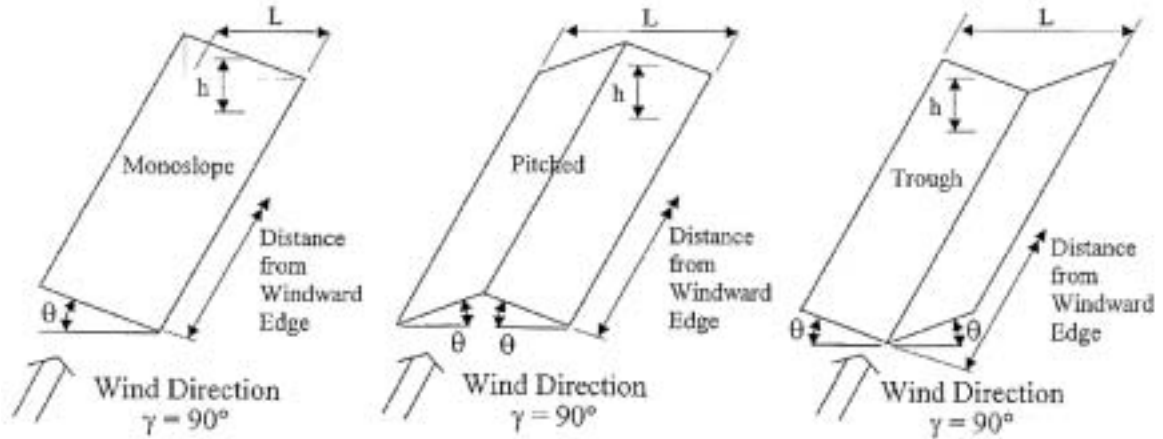

Horizontal Distance from Windward Edge	Roof Angle θ	Load Case	Clear Wind Flow	Obstructed Wind Flow
			C_N	C_N
$\leq h$	All Shapes	A	-0.8	-1.2
	$\theta \leq 45^\circ$	B	0.8	0.5
$> h, \leq 2h$	All Shapes	A	-0.6	-0.9
	$\theta \leq 45^\circ$	B	0.5	0.5
$> 2h$	All Shapes	A	-0.3	-0.6
	$\theta \leq 45^\circ$	B	0.3	0.3

Notes:

- C_N denotes net pressures (contributions from top and bottom surfaces).
- Clear wind flow denotes relatively unobstructed wind flow with blockage less than or equal to 50%. Obstructed wind flow denotes objects below roof inhibiting wind flow (>50% blockage).
- Plus and minus signs signify pressures acting towards and away from the top roof surface, respectively.
- All load cases shown for each roof angle shall be investigated.
- For monoslope roofs with theta less than 5 degrees, C_n values shown apply also for cases where gamma = 0 degrees and 0.05 less than or equal to h/L less than or equal to 0.25. See Figure 6-18A for other h/L values.

6. Notation:

- L : horizontal dimension of roof, measured in the along wind direction, ft. (m)
- h : mean roof height, ft. (m)
- γ : direction of wind, degrees
- θ : angle of plane of roof from horizontal, degrees

Components and Cladding		$0.25 \leq h/L \leq 1.0$
Figure 6-19A	Net Pressure Coefficient, C_N	Monoslope Free Roofs
Open Buildings		$\theta \leq 45^\circ$

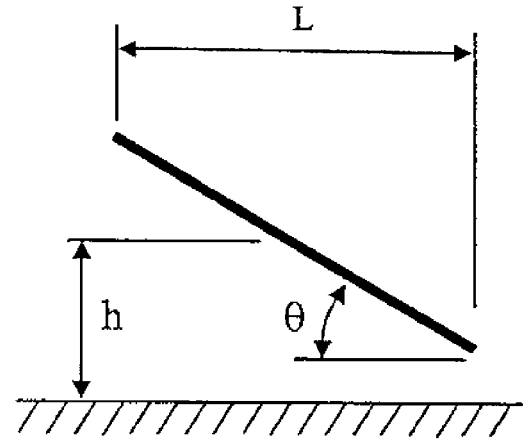
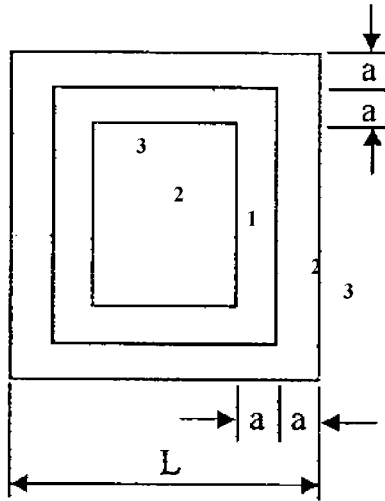

Roof Angle θ	Effective Wind Area	C_N											
		Clear Wind Flow						Obstructed Wind Flow					
		Zone 3		Zone 2		Zone 1		Zone 3		Zone 2		Zone 1	
0°	$\leq a^2$	2.4	-3.3	1.8	-1.7	1.2	-1.1	1	-3.6	0.8	-1.8	0.5	-1.2
	$> a^2, \leq 4.0a^2$	1.8	-1.7	1.8	-1.7	1.2	-1.1	0.8	-1.8	0.8	-1.8	0.5	-1.2
	$> 4.0a^2$	1.2	-1.1	1.2	-1.1	1.2	-1.1	0.5	-1.2	0.5	-1.2	0.5	-1.2
7.5°	$\leq a^2$	3.2	-4.2	2.4	-2.1	1.6	-1.4	1.6	-5.1	1.2	-2.6	0.8	-1.7
	$> a^2, \leq 4.0a^2$	2.4	-2.1	2.4	-2.1	1.6	-1.4	1.2	-2.6	1.2	-2.6	0.8	-1.7
	$> 4.0a^2$	1.6	-1.4	1.6	-1.4	1.6	-1.4	0.8	-1.7	0.8	-1.7	0.8	-1.7
15°	$\leq a^2$	3.6	-3.8	2.7	-2.9	1.8	-1.9	2.4	-4.2	1.8	-3.2	1.2	-2.1
	$> a^2, \leq 4.0a^2$	2.7	-2.9	2.7	-2.9	1.8	-1.9	1.8	-3.2	1.8	-3.2	1.2	-2.1
	$> 4.0a^2$	1.8	-1.9	1.8	-1.9	1.8	-1.9	1.2	-2.1	1.2	-2.1	1.2	-2.1
30°	$\leq a^2$	5.2	-5	3.9	-3.8	2.6	-2.5	3.2	-4.6	2.4	-3.5	1.6	-2.3
	$> a^2, \leq 4.0a^2$	3.9	-3.8	3.9	-3.8	2.6	-2.5	2.4	-3.5	2.4	-3.5	1.6	-2.3
	$> 4.0a^2$	2.6	-2.5	2.6	-2.5	2.6	-2.5	1.6	-2.3	1.6	-2.3	1.6	-2.3
45°	$\leq a^2$	5.2	-4.6	3.9	-3.5	2.6	-2.3	4.2	-3.8	3.2	-2.9	2.1	-1.9
	$> a^2, \leq 4.0a^2$	3.9	-3.5	3.9	-3.5	2.6	-2.3	3.2	-2.9	3.2	-2.9	2.1	-1.9
	$> 4.0a^2$	2.6	-2.3	2.6	-2.3	2.6	-2.3	2.1	-1.9	2.1	-1.9	2.1	-1.9

Notes:

- C_N denotes net pressures (contributions from top and bottom surfaces).
- Clear wind flow denotes relatively unobstructed wind flow with blockage less than or equal to 50%. Obstructed wind flow denotes objects below roof inhibiting wind flow (>50% blockage).
- For values of θ other than those shown, linear interpolation is permitted.
- Plus and minus signs signify pressures acting towards and away from the top roof surface, respectively.
- Components and cladding elements shall be designed for positive and negative pressure coefficients shown.
- Notation:

a : 10% of least horizontal dimension or 0.4h, whichever is smaller but not less than 4% of least horizontal dimension or 3 ft. (0.9 m)

h : mean roof height, ft. (m)

L : horizontal dimension of building, measured in along wind direction, ft. (m)

θ : angle of plane of roof from horizontal, degrees

Components and Cladding		$0.25 \leq h/L \leq 1.0$
Figure 6-19B	Net Pressure Coefficient, C_N	Monoslope Free Roofs
Open Buildings		$\theta \leq 45^\circ$

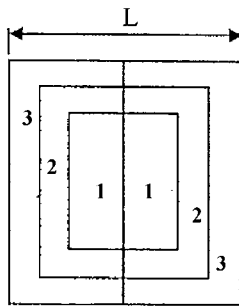

$\theta < 10^\circ$

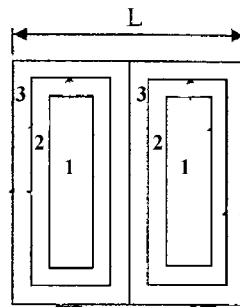

$\theta \geq 10^\circ$

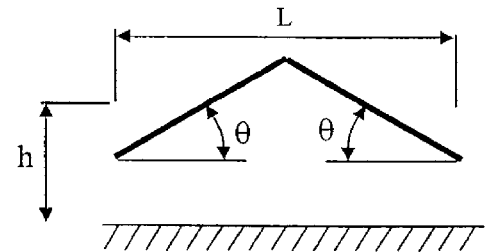

Roof Angle θ	Effective Wind Area	C_N											
		Clear Wind Flow						Obstructed Wind Flow					
		Zone 3		Zone 2		Zone 1		Zone 3		Zone 2		Zone 1	
0°	$\leq a^2$	2.4	-3.3	1.8	-1.7	1.2	-1.1	1	-3.6	0.8	-1.8	0.5	-1.2
	$> a^2, \leq 4.0a^2$	1.8	-1.7	1.8	-1.7	1.2	-1.1	0.8	-1.8	0.8	-1.8	0.5	-1.2
	$> 4.0a^2$	1.2	-1.1	1.2	-1.1	1.2	-1.1	0.5	-1.2	0.5	-1.2	0.5	-1.2
7.5°	$\leq a^2$	2.2	-3.6	1.7	-1.8	1.1	-1.2	1	-5.1	0.8	-2.6	0.5	-1.7
	$> a^2, \leq 4.0a^2$	1.7	-1.8	1.7	-1.8	1.1	-1.2	0.8	-2.6	0.8	-2.6	0.5	-1.7
	$> 4.0a^2$	1.1	-1.2	1.1	-1.2	1.1	-1.2	0.5	-1.7	0.5	-1.7	0.5	-1.7
15°	$\leq a^2$	2.2	-2.2	1.7	-1.7	1.1	-1.1	1	-3.2	0.8	-2.4	0.5	-1.6
	$> a^2, \leq 4.0a^2$	1.7	-1.7	1.7	-1.7	1.1	-1.1	0.8	-2.4	0.8	-2.4	0.5	-1.6
	$> 4.0a^2$	1.1	-1.1	1.1	-1.1	1.1	-1.1	0.5	-1.6	0.5	-1.6	0.5	-1.6
30°	$\leq a^2$	2.6	-1.8	2	-1.4	1.3	-0.9	1	-2.4	0.8	-1.8	0.5	-1.2
	$> a^2, \leq 4.0a^2$	2	-1.4	2	-1.4	1.3	-0.9	0.8	-1.8	0.8	-1.8	0.5	-1.2
	$> 4.0a^2$	1.3	-0.9	1.3	-0.9	1.3	-0.9	0.5	-1.2	0.5	-1.2	0.5	-1.2
45°	$\leq a^2$	2.2	-1.6	1.7	-1.2	1.1	-0.8	1	-2.4	0.8	-1.8	0.5	-1.2
	$> a^2, \leq 4.0a^2$	1.7	-1.2	1.7	-1.2	1.1	-0.8	0.8	-1.8	0.8	-1.8	0.5	-1.2
	$> 4.0a^2$	1.1	-0.8	1.1	-0.8	1.1	-0.8	0.5	-1.2	0.5	-1.2	0.5	-1.2

Notes:

- C_N denotes net pressures (contributions from top and bottom surfaces).
- Clear wind flow denotes relatively unobstructed wind flow with blockage less than or equal to 50%. Obstructed wind flow denotes objects below roof inhibiting wind flow (>50% blockage).
- For values of θ other than those shown, linear interpolation is permitted.
- Plus and minus signs signify pressures acting towards and away from the top roof surface, respectively.
- Components and cladding elements shall be designed for positive and negative pressure coefficients shown.
- Notation:
 - a : 10% of least horizontal dimension or 0.4h, whichever is smaller but not less than 4% of least horizontal dimension or 3 ft. (0.9 m)
 - h : mean roof height, ft. (m)
 - L : horizontal dimension of building, measured in along wind direction, ft. (m)
 - θ : angle of plane of roof from horizontal, degrees

Components and Cladding		$0.25 \leq h/L \leq 1.0$
Figure 6-19C	Net Pressure Coefficient, C_N	Troughed Free Roofs
Open Buildings		$\theta \leq 45^\circ$

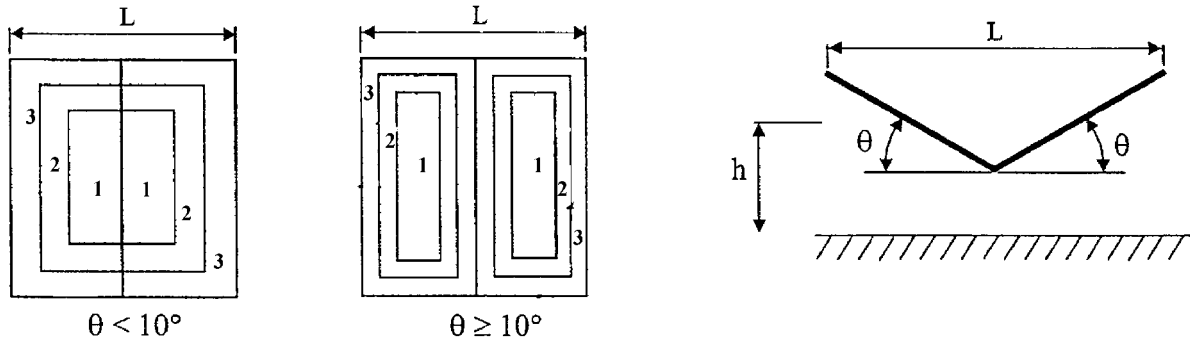

Roof Angle θ	Effective Wind Area	C_N											
		Clear Wind Flow						Obstructed Wind Flow					
		Zone 3		Zone 2		Zone 1		Zone 3		Zone 2		Zone 1	
0°	$\leq a^2$	2.4	-3.3	1.8	-1.7	1.2	-1.1	1	-3.6	0.8	-1.8	0.5	-1.2
	$> a^2, \leq 4.0a^2$	1.8	-1.7	1.8	-1.7	1.2	-1.1	0.8	-1.8	0.8	-1.8	0.5	-1.2
	$> 4.0a^2$	1.2	-1.1	1.2	-1.1	1.2	-1.1	0.5	-1.2	0.5	-1.2	0.5	-1.2
7.5°	$\leq a^2$	2.4	-3.3	1.8	-1.7	1.2	-1.1	1	-4.8	0.8	-2.4	0.5	-1.6
	$> a^2, \leq 4.0a^2$	1.8	-1.7	1.8	-1.7	1.2	-1.1	0.8	-2.4	0.8	-2.4	0.5	-1.6
	$> 4.0a^2$	1.2	-1.1	1.2	-1.1	1.2	-1.1	0.5	-1.6	0.5	-1.6	0.5	-1.6
15°	$\leq a^2$	2.2	-2.2	1.7	-1.7	1.1	-1.1	1	-2.4	0.8	-1.8	0.5	-1.2
	$> a^2, \leq 4.0a^2$	1.7	-1.7	1.7	-1.7	1.1	-1.1	0.8	-1.8	0.8	-1.8	0.5	-1.2
	$> 4.0a^2$	1.1	-1.1	1.1	-1.1	1.1	-1.1	0.5	-1.2	0.5	-1.2	0.5	-1.2
30°	$\leq a^2$	1.8	-2.6	1.4	-2	0.9	-1.3	1	-2.8	0.8	-2.1	0.5	-1.4
	$> a^2, \leq 4.0a^2$	1.4	-2	1.4	-2	0.9	-1.3	0.8	-2.1	0.8	-2.1	0.5	-1.4
	$> 4.0a^2$	0.9	-1.3	1.9	-1.3	0.9	-1.3	0.5	-1.4	0.5	-1.4	0.5	-1.4
45°	$\leq a^2$	1.6	-2.2	1.2	-1.7	0.8	-1.1	1	-2.4	0.8	-1.8	0.5	-1.2
	$> a^2, \leq 4.0a^2$	1.2	-1.7	1.2	-1.7	0.8	-1.1	0.8	-1.8	0.8	-1.8	0.5	-1.2
	$> 4.0a^2$	0.8	-1.1	1.8	-1.1	0.8	-1.1	0.5	-1.2	0.5	-1.2	0.5	-1.2

Notes:

- C_N denotes net pressures (contributions from top and bottom surfaces).
- Clear wind flow denotes relatively unobstructed wind flow with blockage less than or equal to 50%. Obstructed wind flow denotes objects below roof inhibiting wind flow (>50% blockage).
- For values of θ other than those shown, linear interpolation is permitted.
- Plus and minus signs signify pressures acting towards and away from the top roof surface, respectively.
- Components and cladding elements shall be designed for positive and negative pressure coefficients shown.

Notation:

- a : 10% of least horizontal dimension or $0.4h$, whichever is smaller but not less than 4% of least horizontal dimension or 3 ft. (0.9 m)
- h : mean roof height, ft. (m)
- L : horizontal dimension of building, measured in along wind direction, ft. (m)
- θ : angle of plane of roof from horizontal, degrees

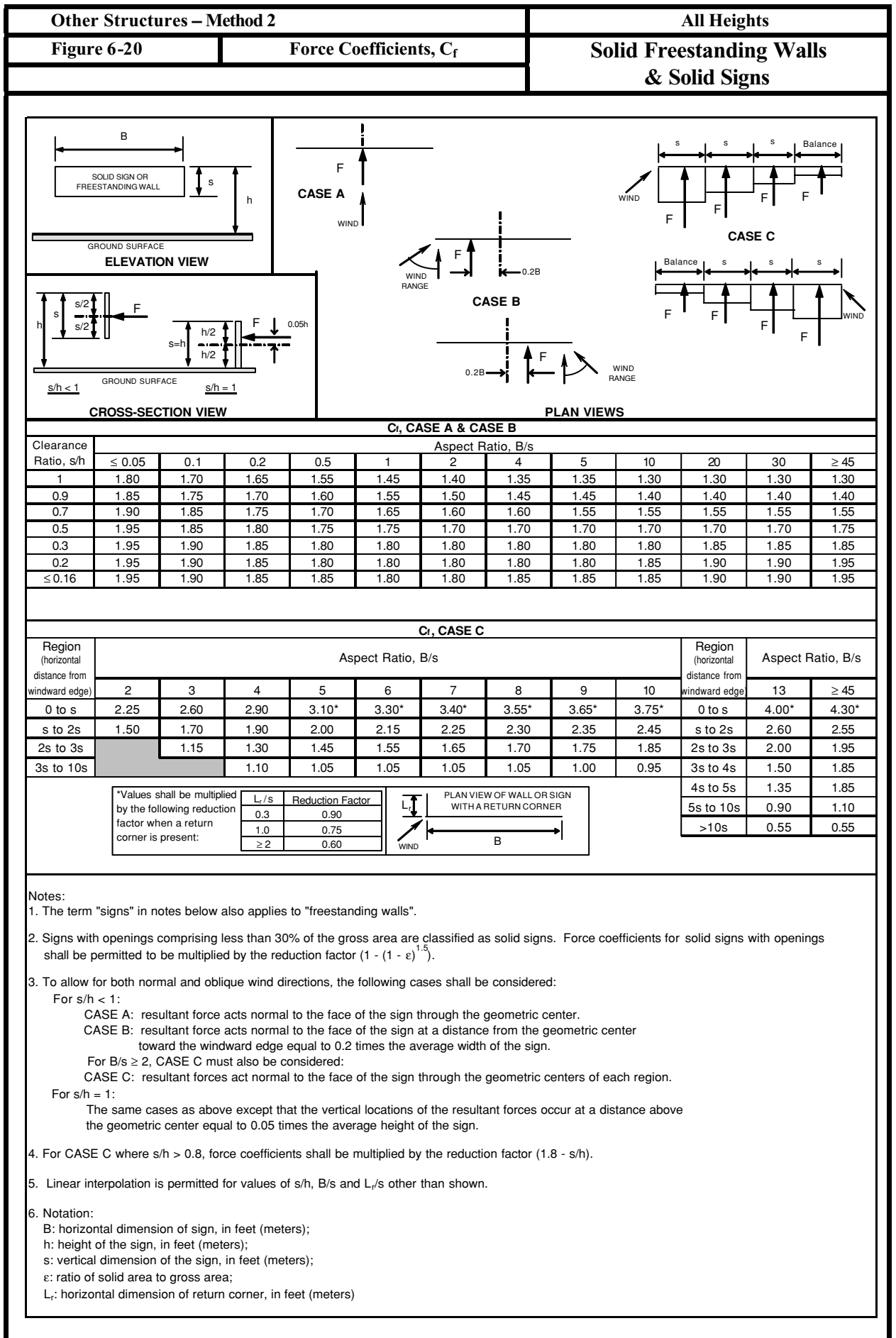

Other Structures – Method 2		All Heights
Figure 6-21	Force Coefficients, C_f	Chimneys, Tanks, Rooftop Equipment, & Similar Structures

Cross-Section	Type of Surface	h/D		
		1	7	25
Square (wind normal to face)	All	1.3	1.4	2.0
Square (wind along diagonal)	All	1.0	1.1	1.5
Hexagonal or octagonal	All	1.0	1.2	1.4
Round ($D\sqrt{q_z} > 2.5$) ($D\sqrt{q_z} > 5.3$, D in m, q_z in N/m^2)	Moderately smooth	0.5	0.6	0.7
	Rough ($D'/D = 0.02$)	0.7	0.8	0.9
	Very rough ($D'/D = 0.08$)	0.8	1.0	0.2
Round ($D\sqrt{q_z} \leq 2.5$) ($D\sqrt{q_z} \leq 5.3$, D in m, q_z in N/m^2)	All	0.7	0.8	1.2

Notes:

- The design wind force shall be calculated based on the area of the structure projected on a plane normal to the wind direction. The force shall be assumed to act parallel to the wind direction.
- Linear interpolation is permitted for h/D values other than shown.
- Notation:
 - D : diameter of circular cross-section and least horizontal dimension of square, hexagonal or octagonal cross-sections at elevation under consideration, in feet (meters);
 - D' : depth of protruding elements such as ribs and spoilers, in feet (meters); and
 - h : height of structure, in feet (meters); and
 - q_z : velocity pressure evaluated at height z above ground, in pounds per square foot (N/m^2).

Other Structures – Method 2		All Heights																			
Figure 6-22	Force Coefficients, C_f	Open Signs & Lattice Frameworks																			
<table border="1"> <thead> <tr> <th rowspan="2">ϵ</th> <th rowspan="2">Flat-Sided Members</th> <th colspan="2">Rounded Members</th> </tr> <tr> <th>$D\sqrt{q_z} \leq 2.5$ ($D\sqrt{q_z} \leq 5.3$)</th> <th>$D\sqrt{q_z} > 2.5$ ($D\sqrt{q_z} > 5.3$)</th> </tr> </thead> <tbody> <tr> <td>< 0.1</td> <td>2.0</td> <td>1.2</td> <td>0.8</td> </tr> <tr> <td>0.1 to 0.29</td> <td>1.8</td> <td>1.3</td> <td>0.9</td> </tr> <tr> <td>0.3 to 0.7</td> <td>1.6</td> <td>1.5</td> <td>1.1</td> </tr> </tbody> </table>				ϵ	Flat-Sided Members	Rounded Members		$D\sqrt{q_z} \leq 2.5$ ($D\sqrt{q_z} \leq 5.3$)	$D\sqrt{q_z} > 2.5$ ($D\sqrt{q_z} > 5.3$)	< 0.1	2.0	1.2	0.8	0.1 to 0.29	1.8	1.3	0.9	0.3 to 0.7	1.6	1.5	1.1
ϵ	Flat-Sided Members	Rounded Members																			
		$D\sqrt{q_z} \leq 2.5$ ($D\sqrt{q_z} \leq 5.3$)	$D\sqrt{q_z} > 2.5$ ($D\sqrt{q_z} > 5.3$)																		
< 0.1	2.0	1.2	0.8																		
0.1 to 0.29	1.8	1.3	0.9																		
0.3 to 0.7	1.6	1.5	1.1																		
<p>Notes:</p> <ol style="list-style-type: none"> Signs with openings comprising 30% or more of the gross area are classified as open signs. The calculation of the design wind forces shall be based on the area of all exposed members and elements projected on a plane normal to the wind direction. Forces shall be assumed to act parallel to the wind direction. The area A_f consistent with these force coefficients is the solid area projected normal to the wind direction. Notation: <ul style="list-style-type: none"> ϵ: ratio of solid area to gross area; D: diameter of a typical round member, in feet (meters); q_z: velocity pressure evaluated at height z above ground in pounds per square foot (N/m^2). 																					

Other Structures – Method 2		All Heights
Figure 6-23	Force Coefficients, C_f	Trussed Towers
Open Structures		

Tower Cross Section	C_f
Square	$4.0 \epsilon^2 - 5.9 \epsilon + 4.0$
Triangle	$3.4 \epsilon^2 - 4.7 \epsilon + 3.4$

Notes:

1. For all wind directions considered, the area A_f consistent with the specified force coefficients shall be the solid area of a tower face projected on the plane of that face for the tower segment under consideration.
2. The specified force coefficients are for towers with structural angles or similar flat-sided members.
3. For towers containing rounded members, it is acceptable to multiply the specified force coefficients by the following factor when determining wind forces on such members:
 $0.51 \epsilon^2 + 0.57$, but not > 1.0
4. Wind forces shall be applied in the directions resulting in maximum member forces and reactions. For towers with square cross-sections, wind forces shall be multiplied by the following factor when the wind is directed along a tower diagonal:
 $1 + 0.75 \epsilon$, but not > 1.2
5. Wind forces on tower appurtenances such as ladders, conduits, lights, elevators, etc., shall be calculated using appropriate force coefficients for these elements.
6. Loads due to ice accretion as described in Section 11 shall be accounted for.
7. Notation:
 ϵ : ratio of solid area to gross area of one tower face for the segment under consideration.

Importance Factor, I (Wind Loads)**Table 6-1**

Category	Non-Hurricane Prone Regions and Hurricane Prone Regions with V = 85-100 mph and Alaska	Hurricane Prone Regions with V > 100 mph
I	0.87	0.77
II	1.00	1.00
III	1.15	1.15
IV	1.15	1.15

Note:

1. The building and structure classification categories are listed in Table 1-1.

Terrain Exposure Constants

Table 6-2

Exposure	α	z_g (ft)	\hat{a}	\hat{b}	$\bar{\alpha}$	\bar{b}	c	ℓ (ft)	$\bar{\epsilon}$	z_{min} (ft)*
B	7.0	1200	1/7	0.84	1/4.0	0.45	0.30	320	1/3.0	30
C	9.5	900	1/9.5	1.00	1/6.5	0.65	0.20	500	1/5.0	15
D	11.5	700	1/11.5	1.07	1/9.0	0.80	0.15	650	1/8.0	7

* z_{min} = minimum height used to ensure that the equivalent height \bar{z} is greater of $0.6h$ or z_{min} .
 For buildings with $h \leq z_{min}$, \bar{z} shall be taken as z_{min} .

In metric

Exposure	α	z_g (m)	\hat{a}	\hat{b}	$\bar{\alpha}$	\bar{b}	c	ℓ (m)	$\bar{\epsilon}$	z_{min} (m)*
B	7.0	365.76	1/7	0.84	1/4.0	0.45	0.30	97.54	1/3.0	9.14
C	9.5	274.32	1/9.5	1.00	1/6.5	0.65	0.20	152.4	1/5.0	4.57
D	11.5	213.36	1/11.5	1.07	1/9.0	0.80	0.15	198.12	1/8.0	2.13

* z_{min} = minimum height used to ensure that the equivalent height \bar{z} is greater of $0.6h$ or z_{min} .
 For buildings with $h \leq z_{min}$, \bar{z} shall be taken as z_{min} .

Velocity Pressure Exposure Coefficients, K_h and K_z

Table 6-3

Height above ground level, z		Exposure (Note 1)			
		B		C	D
ft	(m)	Case 1	Case 2	Cases 1 & 2	Cases 1 & 2
0-15	(0-4.6)	0.70	0.57	0.85	1.03
20	(6.1)	0.70	0.62	0.90	1.08
25	(7.6)	0.70	0.66	0.94	1.12
30	(9.1)	0.70	0.70	0.98	1.16
40	(12.2)	0.76	0.76	1.04	1.22
50	(15.2)	0.81	0.81	1.09	1.27
60	(18)	0.85	0.85	1.13	1.31
70	(21.3)	0.89	0.89	1.17	1.34
80	(24.4)	0.93	0.93	1.21	1.38
90	(27.4)	0.96	0.96	1.24	1.40
100	(30.5)	0.99	0.99	1.26	1.43
120	(36.6)	1.04	1.04	1.31	1.48
140	(42.7)	1.09	1.09	1.36	1.52
160	(48.8)	1.13	1.13	1.39	1.55
180	(54.9)	1.17	1.17	1.43	1.58
200	(61.0)	1.20	1.20	1.46	1.61
250	(76.2)	1.28	1.28	1.53	1.68
300	(91.4)	1.35	1.35	1.59	1.73
350	(106.7)	1.41	1.41	1.64	1.78
400	(121.9)	1.47	1.47	1.69	1.82
450	(137.2)	1.52	1.52	1.73	1.86
500	(152.4)	1.56	1.56	1.77	1.89

Notes:

- Case 1:**

 - All components and cladding.
 - Main wind force resisting system in low-rise buildings designed using Figure 6-10.

Case 2:

 - All main wind force resisting systems in buildings except those in low-rise buildings designed using Figure 6-10.
 - All main wind force resisting systems in other structures.
- The velocity pressure exposure coefficient K_z may be determined from the following formula:

For $15 \text{ ft.} \leq z \leq z_g$	For $z < 15 \text{ ft.}$
$K_z = 2.01 (z/z_g)^{2/\alpha}$	$K_z = 2.01 (15/z_g)^{2/\alpha}$

Note: z shall not be taken less than 30 feet for Case 1 in exposure B.
- α and z_g are tabulated in Table 6-2.
- Linear interpolation for intermediate values of height z is acceptable.
- Exposure categories are defined in 6.5.6.

Wind Directionality Factor, K_d **Table 6-4**

Structure Type	Directionality Factor K_d*
Buildings	
Main Wind Force Resisting System	0.85
Components and Cladding	0.85
Arched Roofs	0.85
Chimneys, Tanks, and Similar Structures	
Square	0.90
Hexagonal	0.95
Round	0.95
Solid Signs	0.85
Open Signs and Lattice Framework	0.85
Trussed Towers	
Triangular, square, rectangular	0.85
All other cross sections	0.95

*Directionality Factor K_d has been calibrated with combinations of loads specified in Section 2. This factor shall only be applied when used in conjunction with load combinations specified in 2.3 and 2.4.