

Main Wind Force Resisting System – Part 1		$0.25 \leq h/L \leq 1.0$
Figure 27.4-5	Net Pressure Coefficient, $C_N$	Pitched Free Roofs $\theta \leq 45^\circ, \gamma = 0^\circ, 180^\circ$
Open Buildings		

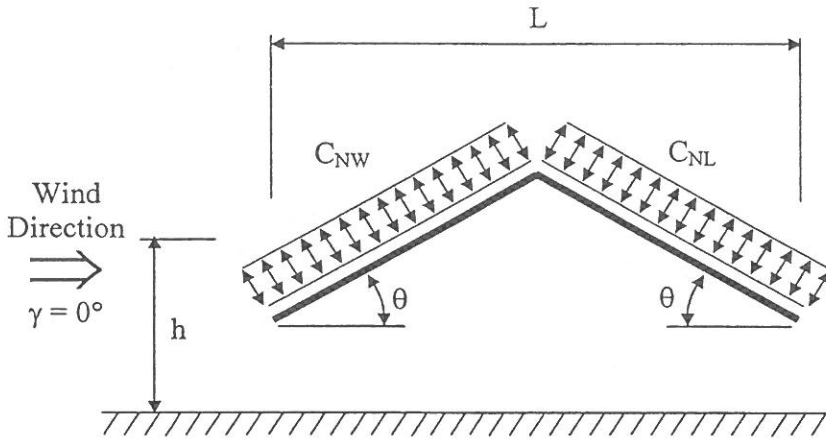

Roof Angle, $\theta$	Load Case	Wind Direction, $\gamma = 0^\circ, 180^\circ$			
		Clear Wind Flow		Obstructed Wind Flow	
		$C_{NW}$	$C_{NL}$	$C_{NW}$	$C_{NL}$
7.5°	A	1.1	-0.3	-1.6	-1
	B	0.2	-1.2	-0.9	-1.7
15°	A	1.1	-0.4	-1.2	-1
	B	0.1	-1.1	-0.6	-1.6
22.5°	A	1.1	0.1	-1.2	-1.2
	B	-0.1	-0.8	-0.8	-1.7
30°	A	1.3	0.3	-0.7	-0.7
	B	-0.1	-0.9	-0.2	-1.1
37.5°	A	1.3	0.6	-0.6	-0.6
	B	-0.2	-0.6	-0.3	-0.9
45°	A	1.1	0.9	-0.5	-0.5
	B	-0.3	-0.5	-0.3	-0.7

**Notes:**

- $C_{NW}$  and  $C_{NL}$  denote net pressures (contributions from top and bottom surfaces) for windward and leeward half of roof surfaces, respectively.
- Clear wind flow denotes relatively unobstructed wind flow with blockage less than or equal to 50%. Obstructed wind flow denotes objects below roof inhibiting wind flow (>50% blockage).
- For values of  $\theta$  between 7.5° and 45°, linear interpolation is permitted. For values of  $\theta$  less than 7.5°, use monoslope roof load coefficients.
- Plus and minus signs signify pressures acting towards and away from the top roof surface, respectively.
- All load cases shown for each roof angle shall be investigated.
- Notation:
  - $L$  : horizontal dimension of roof, measured in the along wind direction, ft. (m)
  - $h$  : mean roof height, ft. (m)
  - $\gamma$  : direction of wind, degrees
  - $\theta$  : angle of plane of roof from horizontal, degrees