

CHAPTER 34

THERMAL STORAGE

Sensible Thermal Storage Technology	34.4	Other Design Considerations	34.25
Heat Storage Technology	34.11	Cost Considerations	34.27
Sizing Cool Storage Systems	34.17	Maintenance Considerations	34.27
Application of Thermal Storage Systems	34.19	Commissioning	34.28
Operation and Control	34.23	Good Practices	34.30

THERMAL storage systems remove heat from or add heat to a storage medium for use at another time. Thermal energy storage for HVAC applications can involve various temperatures associated with heating or cooling. High-temperature storage is typically associated with solar energy or high-temperature heating, and cool storage with air-conditioning, refrigeration, or cryogenic-temperature processes. Energy may be charged, stored, and discharged daily, weekly, annually, or in seasonal or rapid batch process cycles. Currently, most use of thermal storage is cool storage for comfort and process cooling applications as a way to reduce the total utility bill and/or size of cooling equipment, and much of the discussion in this chapter pertains specifically to cool storage. The *Design Guide for Cool Thermal Storage* (Dorgan and Elleson 1993) covers cool storage issues and design parameters in detail.

A properly designed and installed thermal storage system can

- Reduce operating or initial costs
- Reduce size of electric service and cooling or heating equipment
- Increase operating flexibility
- Provide back-up capacity
- Extend the capacity of an existing system

Benefits are discussed further in the Benefits of Thermal Storage section.

Thermal storage may be a particularly attractive approach to meeting heating or cooling loads if one or more of the following conditions apply:

- Loads are of short duration
- Loads occur infrequently
- Loads are cyclical
- Loads are not coincident with energy source availability
- Energy costs are time-dependent (e.g., time-of-use energy rates)
- Charges for peak power demand are high
- Utility rebates, tax credits, or other economic incentives are provided for using load-shifting equipment
- Energy supply is limited, thus limiting or preventing the use of full-size nonstorage systems
- Facility expansion is planned, and the existing heating or cooling equipment is insufficient to meet the new peak load but has spare nonpeak capacity
- Interruption in cooling water cannot be tolerated by a mission-critical operation

Terminology

Charging. Storing cooling capacity by removing heat from a cool storage device, or storing heating capacity by adding heat to a heat storage device.

Chiller priority. Control strategy for partial storage systems that uses the chiller to directly meet as much of the load as possible, normally by operating at full capacity most of the time. Thermal

storage is used to supplement chiller operation only when the load exceeds the chiller capacity.

Cool storage. As used in this chapter, storage of cooling capacity in a storage medium at temperatures below the nominal temperature of the space or process.

Demand limiting. A partial storage operating strategy that limits capacity of refrigeration equipment during the on-peak period. Refrigeration equipment capacity may be limited based on its cooling capacity, its electric demand, or the facility demand.

Design load profile. Calculated or measured hour-by-hour cooling loads over a complete cooling cycle that are considered to be the desired total cooling load that must be met by mechanical refrigeration and capacity from a cool thermal storage system.

Design operating profile. Equipment hour-by-hour operation, including mechanical refrigeration equipment, the thermal storage system's charge or discharge rate, and temperatures over the entire cooling system operating period.

Discharging. Using stored cooling capacity by adding thermal energy to a cool storage device or removing thermal energy from a heat storage device.

Encapsulated storage. A latent storage technology that consists of plastic containers of water or other phase-change material that are alternately frozen and melted by the influence of glycol or other secondary coolant medium in which they are immersed.

Full storage. A cool storage sizing strategy that meets the entire cooling load with discharge from the thermal storage system for some period, typically hours when loads are high and electric power is expensive.

Fully charged condition. State of a cool thermal storage system at which, according to design, no more heat is to be removed from the storage device. This state is generally reached when the control system stops the charge cycle as part of its normal control sequence, or when the maximum allowable charging period has elapsed.

Fully discharged condition. State of a cool thermal storage system at which no more usable cooling capacity can be delivered from the storage device.

Heat storage. As used in this chapter, storage of thermal energy at temperatures above the nominal temperature of the space or process.

Ice harvester. Machine that cyclically forms a layer of ice on a smooth cooling surface, using refrigerant inside the heat exchanger, then delivers it to a storage container by heating the surface of the cooling plate, normally by reversing the refrigeration process and delivering hot gases inside the heat exchanger.

Ice-on-coil (ice-on-pipe). Ice storage technology that forms and stores ice on the outside of tubes or pipes submerged in an insulated water tank.

Ice-on-coil, external melt. Ice storage technology in which tubes or pipes (coil) are immersed in water and ice is formed on the outside of the tubes or pipes by circulating colder secondary medium or refrigerant inside the tubing or pipes, and is melted externally by circulating unfrozen water outside the tubes or pipes to the load.

The preparation of this chapter is assigned to TC 6.9, Thermal Storage.

Ice-on-coil, internal melt. Ice storage technology in which tubes or pipes (coil) are immersed in water and ice is formed on the outside of the tubes or pipes by circulating colder secondary medium or refrigerant inside the tubing or pipes, and is melted internally by circulating the same secondary coolant or refrigerant to the load.

Latent energy storage (latent heat storage). A thermal storage technology in which energy is stored within a medium, normally associated with a phase change (usually between solid and liquid states), for use in cooling or heating the secondary liquid being circulated through the system.

Load leveling. A partial storage sizing strategy that minimizes storage equipment size and storage capacity. The system operates with refrigeration equipment running at full capacity for 24 h to meet the normal cooling minimum load profile and, when load is less than the chiller output, excess cooling is stored. When load exceeds chiller capacity, the additional cooling requirement is obtained from the thermal storage.

Load profile. Compilation of instantaneous thermal loads over a period of time, normally 24 h.

Mass storage. Storage of energy, in the form of sensible heat, in building materials, interior equipment, and furnishings.

Maximum usable cooling supply temperature. Maximum fluid supply temperature at which the cooling load can be met. This is generally determined by the requirements of the air-side distribution system or the process.

Maximum usable discharge temperature. Highest temperature at which beneficial cooling can be obtained from the thermal storage device.

Nominal chiller capacity. (1) Chiller capacity at standard Air-Conditioning and Refrigeration Institute (ARI) rating conditions. (2) Chiller capacity at a given operating condition selected for the purpose of quick chiller sizing selections.

Partial storage. A cool storage sizing strategy in which only a portion of the on-peak cooling load is met from thermal storage, with the rest being met by operating the chilling equipment.

Phase-change material (PCM). A substance that undergoes a change of state, normally from solid to liquid or liquid to solid, while absorbing or rejecting thermal energy at a constant temperature.

Pulldown load. Unmet cooling or heating load that accumulates during a period when a cooling or heating system has not operated, or operated in a thermostat setback mode, and which must be met on system start-up before comfort conditions can be achieved. Maximum pulldown load generally occurs on a Monday morning or following an extended shutdown.

Sensible energy storage (sensible heat storage). A heating or cooling thermal storage technology in which all energy stored is in the form of a measurable temperature difference between the hot or chilled water circulating through the system and the storage medium.

Storage cycle. A period in which a complete charge and discharge of a thermal storage device has occurred, beginning and ending at the same state.

Storage inventory. Amount of usable heating or cooling capacity remaining in a thermal storage device.

Storage priority. A control strategy that uses stored cooling to meet as much of the load as possible. Chillers operate only if the load exceeds the storage system's available cooling capacity.

Stratified chilled-water storage. A method of sensible cool thermal energy storage that achieves and maintains an acceptable separation between warm (discharged) and cool (charged) water by forming a thermocline by density differences alone, and not by mechanical separation.

Thermal storage capacity. A value indicating the maximum amount of cooling (or heating) that can be achieved by the stored medium in the thermal storage device.

Discharge capacity. The maximum rate at which cooling can be supplied from a cool storage device.

Nominal storage capacity. A theoretical capacity of the thermal storage device. In many cases, this may be greater than the usable storage capacity. This measure should not be used to compare usable capacities of alternative storage systems.

System capacity. Maximum amount of cooling that can be supplied by the entire cooling system, which may include chillers and thermal storage.

Usable storage capacity. Total amount of beneficial cooling able to be discharged from a thermal storage device. (This may be less than the nominal storage capacity because the distribution header piping may not allow discharging the entire cooling capacity of the thermal storage device.)

Thermal storage device. A container plus all its contents used for storing heating or cooling energy. The heat transfer fluid and accessories, such as heat exchangers, agitators, circulating pumps, flow-switching devices, valves, and baffles that are integral with the container, are considered a part of the thermal storage device.

Thermocline. Thermal layer of water in a chilled-water thermal storage tank, separating warmer water at the top and cooler water at the bottom. The depth of this layer depends on the effectiveness and efficiency of the upper and lower diffusers, which are designed to supply and discharge water with minimal mixing. The typical thermocline is 18 to 24 in., and rises and falls when charging and discharging the storage tank.

Total cooling load. Integrated thermal load that must be met by the cooling plant over a given period of time.

Usable cooling. Amount of energy that can actually be delivered to the system or process to meet cooling requirements. Normally, this is the total value of the energy retrieved by supplying the medium at or below the maximum beneficial cooling temperature.

Classification of Systems

Thermal storage systems can be classified according to the type of thermal storage medium, whether they store primarily sensible or latent energy, or the way the storage medium is used. Cool storage media include chilled water, aqueous or nonaqueous fluids, ice, and phase-change materials. Heat storage media include water, brick, stone, and ceramic materials. These media differ in their heat storage capacities, the temperatures at which energy is stored, and physical requirements of storing energy in the media. Types of cool storage systems include chilled-water storage, chilled-fluid storage, ice harvesting, internal- and external-melt ice-on-coil, encapsulated ice, ice slurry, and phase-change material systems. Types of heat storage systems include brick storage heaters, water storage heaters, and radiant floor heating systems, as well as solar space and water heating and thermally charged water storage tanks.

Storage Media

A wide range of materials can be used as thermal storage media. Materials used for thermal storage should be

- Commonly available
- Low cost
- Environmentally benign
- Nonflammable
- Nonexplosive
- Nontoxic
- Compatible with common HVAC equipment construction materials
- Noncorrosive
- Inert

An ideal thermal storage medium should also have

- Well-documented physical properties
- High density

- High specific heat (for sensible heat storage)
- High heat of fusion (for latent heat storage)
- Good heat transfer characteristics
- Stable properties that do not change over many thermal cycles

Common storage media for sensible energy storage include water, fluid, soil, rock, brick, ceramics, concrete, and various portions of the building structure (or process fluid) being heated or cooled. In HVAC applications, such as air conditioning, space heating, and water heating, water is often the chosen sensible storage medium because it provides many of these desirable characteristics when kept between its freezing and boiling points. For high-temperature energy storage, the storage medium is often rock, brick, or ceramic materials for residential or small commercial applications; oil, oil/rock combinations, or molten salt are often used for large industrial or solar energy power plant applications. Using the building structure itself as passive thermal storage offers advantages under some circumstances (Morris et al. 1994).

Common storage media for latent energy storage include ice, aqueous brine/ice solutions, and other PCMs such as hydrated salts and polymers. Carbon dioxide and paraffin waxes are among the alternative storage media used for latent energy storage at various temperatures. For air-conditioning applications, ice is the most common latent storage medium, because it provides many of the previously listed desirable characteristics.

Basic Thermal Storage Concepts

The fundamental characteristic of thermal storage systems is that they separate the time(s) of generation of heating or cooling from the time(s) of its use. This separation allows thermal storage systems to generate heating or cooling during periods when conditions are most favorable (e.g., the primary energy source is more available or less expensive), which can be independent of the instantaneous thermal load.

A thermal storage system can meet the same total heating or cooling load as a nonstorage system over a given period of time with smaller primary equipment. The total capacity distributed over the period is matched more closely to the total load encountered in the same period. The reduced size and cost of heating or cooling equipment can partially or completely offset the cost of the storage equipment.

Benefits of Thermal Storage

Properly designed, installed, and operated thermal storage systems offer the following benefits for heating and cooling systems.

Energy Cost Savings. The primary benefit of thermal storage is its ability to substantially reduce total operating costs, particularly for systems using electricity as the primary energy source. Thermal storage systems reduce the demand for expensive on-peak electric power, substituting less expensive nighttime power to do the same job. In addition, in many cases thermal energy storage systems actually consume less energy to deliver the same amount of cooling, primarily because of more efficient use of cooling equipment and the constant temperature of the delivered medium.

Reduced Equipment Size. Heating or cooling equipment can be sized to meet the average load rather than the peak load, and the thermal storage system can be sized to pick up the difference in the load.

Capital Cost Savings. The capital savings from downsizing cooling equipment can more than offset the added cost of the storage system (Andrepoint 2005). Cool storage integrated with low-temperature air and water distribution systems can also provide an initial cost savings by using smaller chillers, pumps, piping, ducts, and fans. Smaller cooling equipment often allows designers to downsize the transformers and electrical distribution systems that supply power for cooling. This economic benefit can be significant, both in new construction, and in existing facilities where electrical

systems are at or near their full capacity. In some areas, government or utility company incentives are available that can further reduce capital costs.

Energy Savings. Although thermal storage systems are generally designed primarily to shift energy use rather than to conserve energy, they can fill both roles. Cool storage systems allow chillers to operate more at night, when lower condensing temperatures improve equipment efficiency. In addition, thermal storage allows operation of equipment at full load, avoiding inefficient part-load performance. Documented examples include chilled-water storage installations that reduce annual energy consumption on a ton-hour basis for air conditioning by up to 12% (Bahnfleth and Joyce 1994; Fiorino 1994). Heat recovery from chiller condensers can also reduce, or even eliminate, the need for heating equipment and associated energy use by combining cooling thermal storage with heating thermal storage (Goss et al. 1996).

Improved HVAC Operation. Thermal storage allows the thermal load profile to be decoupled from operation of the heating or cooling equipment. This decoupling enables plants to use the optimum combination of primary equipment and storage at any given time, providing increased flexibility, reliability, and efficiency in all seasons.

Back-Up Capacity. Cool storage can substantially reduce the installed cost for back-up or emergency cooling systems by reducing the need for redundant electrical and mechanical equipment. Back-up cooling for critical areas (e.g., computer rooms, hospital operating rooms) can be immediately available from the storage reservoir.

Extending Existing Systems' Capacity. The apparent capacity of existing systems can often be increased by installing cool storage at less cost than adding conventional nonstorage equipment. A chilled-water storage tank adds cooling capacity to an existing system and may avoid the high expense of installing new chillers. With this form of thermal storage, existing chillers can now operate during normally off hours to generate the additional cooling needed. The cooling capability of existing ductwork and piping can also be increased by using cool storage. Supplying chilled water and air at lower temperatures allows existing distribution systems to meet substantially higher loads and reduces pump or fan energy consumption.

Other Benefits. Thermal storage can bring about other beneficial synergies. As already noted, cool storage can be integrated with cold-air distribution. A chilled-water storage tank can serve double duty by providing a fire protection water supply at a much lower cost than installing separate systems (Holness 1992; Hussain and Peters 1992; Meckler 1992). Some cool storage systems can be configured for charging with free cooling. Thermal storage can also be used to recover waste energy from base-loaded steam plants by storing chilled water produced by an absorption chiller for later use on demand.

Design Considerations

Thermal storage systems must be designed to meet the total integrated load as well as the peak hourly load. To properly size a thermal storage system, a designer must calculate an accurate load profile and analyze the thermal performance of the storage equipment over the entire storage cycle. Proper sizing is essential. An undersized thermal storage system is limited in its ability to recover when the load exceeds its capacity. On the other hand, excessive oversizing quickly diminishes the economic benefits of thermal storage. Load calculations and system sizing are discussed in Dorgan and Elleson (1993).

Thermal performance of a thermal storage device varies, depending on the current inventory of stored energy and rate of discharge. Therefore, the total capacity of a given thermal storage device depends on the load profile to which it is subjected. There is no standard method for rating cool storage capacity, so performance

specifications must detail the required thermal performance for each hour of the storage cycle. Thermal performance specifications for cool storage systems are discussed in ASHRAE *Guideline 4*.

A thermal storage system must be controlled according to two separate time schedules. Generation of heating or cooling is controlled on a different schedule from the distribution and utilization.

Thermal storage offers the flexibility to supply heating or cooling from storage, from primary equipment, or from both. With this flexibility comes the need to define how the system will be controlled at any given time. The intended strategy for operation and control must be defined as part of the design procedure, as described in Dorgan and Elleson (1993).

SENSIBLE THERMAL STORAGE TECHNOLOGY

Sensible Energy Storage

Water is well suited for both hot and cold sensible energy storage applications and is the most common sensible storage medium, in part because it has the highest specific heat (1 Btu/lb·°F) of all common materials. ASHRAE *Standard 94.3* covers procedures for measuring thermal performance of sensible heat storage. Tanks are available in many shapes; however, vertical cylinders are the most common. Tanks can be located above ground, partially buried, or completely buried. They can also be incorporated into the building structure. For economic reasons, they usually operate at atmospheric pressure and may have clear-span dome roofs, column-supported shallow cone roofs, or column-supported flat roofs. Sensible thermal storage vessels must separate the cooler and warmer volumes of storage medium. This section focuses on chilled-water thermal energy storage because it is the most common system type. However, similar techniques apply to hot-water sensible energy storage for heating systems and to aqueous and nonaqueous stratification fluids for cool storage.

Temperature Range and Storage Size

The cooling capacity of a chilled-water storage vessel is proportional to the volume of water stored and the temperature differential (Δt) between the stored cool water and returning warm water. There is a direct relationship between Δt and the size of sensible storage system components. For economical storage, therefore, the cooling loads served by the system should provide as large a Δt as practical. Many chilled-water systems are designed to operate with a Δt between supply and return of 12 to 16°F. Designing for an achievable 20 to 24°F Δt has the potential to decrease storage vessel size by as much as 50% relative to this typical range. The cost of the extra coil surface required to provide this larger Δt can be more than offset by cost reductions of a smaller tank, reduced pipe and insulation size, and significantly reduced pumping energy. Storage is likely to be uneconomical if the Δt is less than about 10°F because the tank must be so large (Caldwell and Bahnfleth 1997). Typical design and operating conditions result in a storage density of approximately 100 gal/ton-h. Maintaining a Δt as large as possible is very important in achieving the intended beneficial performance of the system. The total performance depends on the behavior of connected loads and needs to be addressed as a system issue.

The initial cost of chilled-water cool storage benefits from a dramatic economy of scale; that is, large installations can be much less expensive per amount of discharge than equivalent nonstorage chilled-water plants (Andrepoint 1992, 2005; Andrepoint and Kohlenberg 2005; Andrepoint and Rice 2002).

Techniques for Thermal Separation in Sensible Storage Devices

The following methods have been applied in chilled-water storage. Thermal stratification has become the dominant method

because of its simplicity, reliability, efficiency, and low cost. The other methods are described only for reference.

Thermal Stratification. In stratified cool storage, warmer, less dense return water floats on top of denser chilled water. Cool water from storage is supplied and withdrawn at low velocity, in essentially horizontal flow, so buoyancy forces dominate inertial effects. Pure water is most dense at 39.2°F; therefore, colder water introduced into the bottom of a stratified tank tends to mix to this temperature with warmer water in the tank. However, low-temperature fluids (LTFs), typically water with various admixtures, can be used to achieve lower delivery temperatures, larger temperature differences, and thus smaller storage volumes per ton-hour (Andrepoint 2000; Borer and Schwartz 2005).

When the stratified storage tank is charged, chilled supply water, typically between 38 and 44°F, enters through the diffuser at the bottom of the tank (Figure 1), and the warmer return water exits to the chiller through the diffuser at the top of the tank. Typically, incoming water mixes with water in the tank to form a 1 to 2 ft thick thermocline, which is a region with sharp vertical temperature and density gradients (Figure 2). The thermocline minimizes further mixing of the water above it with that below it. The thermocline rises as charging continues and subsequently falls during discharging. It may thicken somewhat during charging and discharging because of heat conduction through the water and heat transfer to and from the walls of the tank. The storage tank may have any cross section, but the walls are usually vertical. Horizontal cylindrical tanks are generally not good candidates for stratified storage, because of the ratio of the volume of water within and outside the thermocline.

Flexible Diaphragm. A flexible barrier, normally made from a rubber composition material, installed horizontally inside the water storage tank, separates the colder and warmer water. The diaphragm must be sized to float from the top of the tank to the bottom as the tank is fully charged to fully discharged. Potential for the diaphragm to hang up during travel through the tank and lost volume at the top and bottom of its travel reduce the effectiveness of this method.

Multiple Compartments or Multiple Tanks. Multiple compartments in a single tank or a series of two or more tanks can also be used for chilled-water storage. Water may flow through compartments in series, with opposite flow directions during charging and discharging. In empty tank systems, there is one more compartment than required to contain the full stored volume. During charging and discharging, one of the full compartments is emptied while the empty compartment is filled. This is done sequentially until charging or discharging is complete. Consequently, warmer and cooler water never occupy a tank at the same time. This procedure allows using horizontal or vertical tanks of any configuration and size; drawbacks are the complexity of controls and the need to have an empty tank.

Labyrinth Tank. This storage tank has both horizontal and vertical traverses. The design commonly takes the form of successive

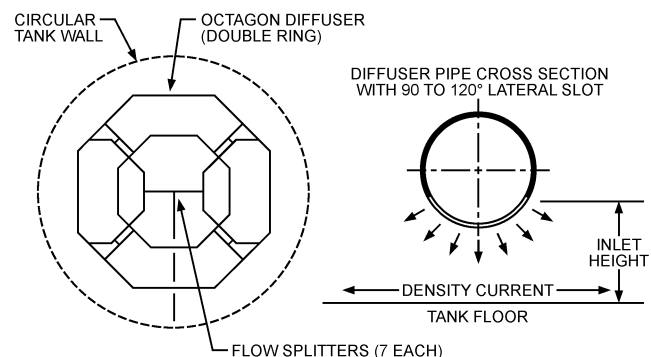

Fig. 1 Typical Two-Ring Octagonal Slotted Pipe Diffuser

cubicles with high and low ports, requiring the water to move from a high to a low port as the storage tank is being charged and the opposite as the tank is being discharged. Strings of cylindrical tanks and tanks with successive vertical weirs may also be used for this technique.

Performance of Chilled-Water Storage Systems

A perfect sensible storage device would deliver water at the same temperature at which it was initially stored. This would also require that water returning to storage neither mix with nor exchange heat with stored water in the tank or the surroundings of the tank. In practice, however, all three types of heat exchange occur.

Typical temperature profiles of water entering and leaving a storage tank are shown in Figure 3. Tran et al. (1989) tested several large chilled-water storage systems and developed the **figure of merit (FOM)**, which is used as a measure of the amount of cooling available from the storage tank.

$$FOM = \frac{\text{Area between A and C}}{\text{Area between A and D}} \times 100 \quad (1)$$

Well-designed storage tanks have figures of merit of 90% or higher for daily complete charge/discharge cycles.

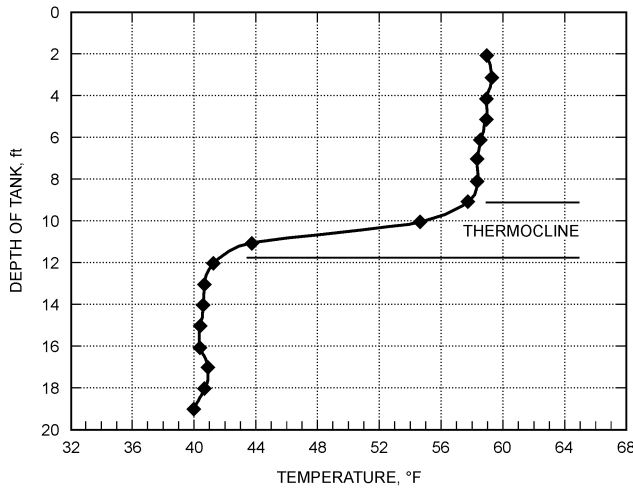

Fig. 2 Typical Temperature Stratification Profile in Storage Tank

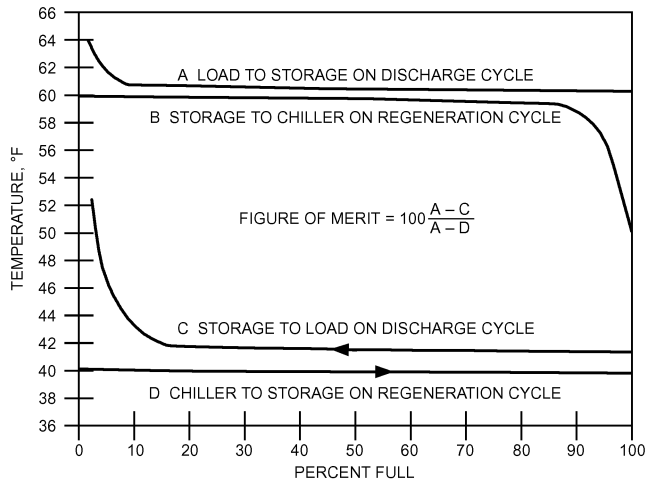

Fig. 3 Typical Chilled-Water Storage Profiles

Design of Stratification Diffusers

Diffusers must be designed and constructed to produce and maintain stratification at the maximum expected flow rate through storage. Two main styles are in widespread use today: the octagonal pipe diffuser (see Figure 1) and the radial disk diffuser (Figure 4). Inlet and outlet streams must be kept at sufficiently low velocities, so buoyancy predominates over inertia to produce a gravity current (density current) across the bottom or top of the tank.

The inlet Froude number *Fr* is defined as

$$Fr = \frac{Q}{\sqrt{gh^3(\Delta\rho/\rho)}} \quad (2)$$

where

- Q* = volume flow rate per unit length of diffuser, ft³/s·ft
- g* = gravitational acceleration, ft/s²
- h* = inlet opening height, ft
- ρ = inlet water density, lb/ft³
- $\Delta\rho$ = difference in density between stored water and incoming or outflowing water, lb/ft³

The density difference $\Delta\rho$ can be obtained from Table 1. The inlet Reynolds number *Re* is defined as follows:

$$Re = Q/\nu \quad (3)$$

where ν = kinematic viscosity, ft²/s.

Designers typically select values for *Re*, which determines the diffuser length, then select a value for the diffuser height to create an inlet Froude number of 1.0 or less. However, values up to 2.0 have been successfully applied (Yoo et al. 1986). Some experimental evidence indicates that the intensity of mixing near the inlet diffuser is influenced by the inlet Reynolds number [Equation (3)].

Wildin and Truman (1989), observing results from a 15 ft deep, 20 ft diameter vertical cylindrical tank, found that reduction of the inlet Reynolds number from 850 (using a radial disk diffuser) to 240 (using a diffuser comprised of pipes in an octagonal array) reduced mixing to negligible proportions. This is consistent with subsequent results obtained by Wildin (1991, 1996) in a 3 ft deep scale model

Table 1 Chilled-Water Density Table

°F	lb/ft ³	°F	lb/ft ³	°F	lb/ft ³
32	62.419	44	62.424	58	62.378
34	62.424	46	62.421	60	62.368
36	62.426	48	62.417	62	62.357
38	62.427	50	62.411	64	62.344
39	62.428	52	62.404	66	62.331
40	62.427	54	62.396	68	62.316
42	62.426	56	62.387		

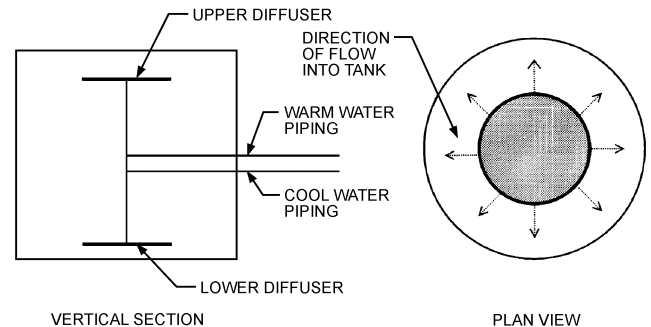

Fig. 4 Radial Disk Diffuser

tank, which indicated negligible mixing at Reynolds numbers below approximately 450, with the best performance achieved during testing at a Reynolds number of 250.

Bahnfleth and Joyce (1994), Musser and Bahnfleth (1998, 1999), and Stewart (2001) documented successful operation of tanks with water depths greater than 45 ft for design inlet Reynolds numbers as high as 10,000, although thermal performance of these systems improved at lower inlet Reynolds numbers.

A parametric study of radial diffusers by Musser and Bahnfleth (2001) found that using Froude numbers less than 1.0 significantly improved performance. Their work, based on field measurements and simulation, confirmed that the Froude number is a parameter of first-order significance for radial diffuser inlet thermal performance, but did not indicate strong effects of varying the Re . They found that parameters relating diffuser and tank dimensions (i.e., ratio of diffuser diameter to diffuser height and ratio of diffuser diameter to tank diameter) had a stronger effect on performance and could explain some of the behavior attributed to Re by earlier research. A similar study of octagonal diffusers by Bahnfleth et al. (2003a) also indicated that diffuser/tank parameters not previously used in design could be of greater significance than Re . They also concluded that diffuser/tank interaction parameters could be important factors in octagonal diffuser performance, and that radial and pipe diffusers are not well described by a single design method.

Because a chilled-water system may experience severe pressure spikes (water hammer), such as during rapid closing of control or isolation valves, the structural design of diffusers should consider this potential event. In addition, the diffusers themselves can also be subjected to buoyancy effects in the rare instance where air entrained in the chilled-water system becomes trapped in the piping and flows to the diffuser. Design considerations should be made to allow any trapped air to escape from the diffuser piping with little or no effect on diffuser performance.

Storage Tank Insulation

Exposed tank surfaces should be well insulated to help maintain the temperature differential in the tank. Insulation is especially important for smaller storage tanks because the ratio of surface area to stored volume is relatively high. Heat transfer between the stored water and tank contact surfaces (including divider walls) is a primary source of capacity loss. In addition to heat losses or gains by conduction through the floor and wall, heat flows vertically along the tank walls from the warmer to the cooler region. Exterior insulation of the tank walls does not totally inhibit this heat transfer.

The contents of chilled-water storage tanks are typically colder than the ambient dew-point temperature, so it is important that the insulation system use a high-integrity exterior vapor barrier to minimize ingress of moisture and condensation into the insulation system.

Other Factors

The cost of chemicals for water treatment may be significant, especially if the tank is filled more than once during its life. A filter system helps keep stored water clean. Exposure of stored water to the atmosphere may require the occasional addition of biocides. Although tanks should be designed to prohibit leakage, the designer should understand the potential effect of leakage on the selection of chemical water treatment. Water treatment based on requirements for a truly open system such as a condenser water system may be excessive, because water in a stratified tank is not aerated and is exposed to the atmosphere only through a small vent at the top of the storage tank. Owners should be careful to consider all factors involved when implementing a water treatment plan. The water treatment should be flexible based on the quantity of makeup water added to the system. See the Water Treatment section for more information.

The storage circulating pumps should be installed below the minimum operating water level of the lowest tank to ensure a

continuously pressurized flooded suction. The required net positive suction head (NPSH) must be maintained to avoid cavitation of the pumps.

Chilled-Water Storage Tanks

Chilled-water storage systems are typically of large capacity and volume. As a result, many stratified chilled-water storage systems are located outdoors (e.g., in industrial plants or suburban campus locations). A tall tank is desirable for stratification, but a buried tank may be required for architectural, aesthetic, or zoning reasons. Tanks are typically constructed of steel or prestressed concrete to specifications used for municipal water storage tanks. Prestressed concrete tanks can be partially or completely buried below grade. For tanks that are completely buried, the tank roof can be free-standing dome type construction, or column-supported for heavy roof loads such as parking lots, tennis courts, or parks.

Low-Temperature Fluid Sensible Energy Storage

Low-temperature fluids (LTFs) may be used as a sensible cool storage medium instead of water. Using an LTF can allow sensible energy thermal storage at temperatures below 39.2°F, the temperature at which the maximum density of plain water occurs. Thus, LTFs can allow lower-temperature applications of sensible energy storage, such as for low-temperature air conditioning and some food processing applications. LTFs can be either aqueous solutions containing a chemical additive, or nonaqueous chemicals. A number of potential LTFs have been identified by Stewart (2000). One LTF has been in continuous commercial service in a stratified thermal storage tank in a very large district cooling system since 1994, and has exhibited good corrosion inhibition and microbiological control properties (Andrepoint 2000, 2006).

Storage in Aquifers

Aquifers are underground, water-yielding geological formations, either unconsolidated (gravel and sand) or consolidated (rocks), that can be used to store large quantities of thermal energy. In general, the natural aquifer water temperature is slightly warmer than the local mean annual air temperature. Aquifer thermal energy storage has been used for process cooling, space cooling, space heating, and ventilation air preheating (Jenne 1992). Aquifers can be used as heat pump sinks or sources and to store energy from ambient winter air, waste heat, and renewable sources. For more information, see [Chapter 32](#).

The thickness and porosity of the aquifer determine the storage volume. Two separate wells are normally used to charge and discharge aquifer storage. A well pair may be pumped either (1) constantly in one direction or (2) alternately from one well to the other, especially when both heating and cooling are provided. Backflushing is recommended to maintain good well efficiency.

The length of storage depends on the local climate and the type of building or process being supplied with cooling or heating. Aquifer thermal energy storage may be used on a short- or long-term basis, as the sole source of energy or as partial storage, and at a temperature useful for direct application or needing augmentation by boilers or chillers. It may also be used in combination with a dehumidification system, such as desiccant cooling. The cost effectiveness of aquifer thermal energy storage is based on the avoidance of equipment capital cost and on lower operating cost.

Aquifer thermal energy storage may be incorporated into a building system in a variety of ways, depending on the other components present and the intentions of the designer (CSA 1993; Hall 1993). Control is simplified by separate hot and cold wells that operate on the basis that the last water in is the first water out. This principle ensures that the hottest or coldest water is always available when needed.

Seasonal storage has a large savings potential and began as an environmentally sensitive improvement on the large-scale mining

of groundwater (Hall 1993). The current method reinjects all pumped water to attempt annual thermal balancing (Morofsky 1994; Public Works Canada 1991, 1992; Snijders 1992). Rock caverns have also been used successfully in a manner similar to aquifers to store energy. For example, Oulu, Finland, stores hot water in a cavern for district heating.

Latent Cool Storage Technology

Latent cool storage systems achieve most of their capacity from the latent heat of fusion of a phase-change material, although sensible heat contributes significantly to many designs. The high energy density of latent storage systems allows compact installations and makes factory-manufactured components and systems practical. Latent storage devices are available in a wide variety of distinct technologies that sometimes defy accurate classification. Current categories include internal-melt ice-on-coil, external-melt ice-on-coil, encapsulated, ice harvester, and ice slurry technologies.

A challenge common to all latent energy storage methods is to find an efficient and economical means of achieving the heat transfer necessary to alternately freeze and melt the storage medium. Various methods have been developed to limit or deal with the heat transfer approach temperatures associated with freezing and melting; however, leaving fluid temperatures (from storage during melting) must be higher than the freezing point, and entering fluid temperatures (to storage during freezing) must be lower than the freezing point. Ice storage can provide leaving temperatures well below those normally used for comfort and nonstorage air-conditioning applications. However, entering temperatures are also much lower than normal. Some PCM storage systems can be charged using temperatures near those for comfort cooling, but they produce warmer leaving temperatures.

Water as Phase-Change Thermal Storage Medium

An overwhelming majority of latent storage systems use plain water as the storage medium. A number of other materials have been developed over the years and are sometimes used in unique applications. However, water's combination of reliability, stability, insignificant cost, high latent heat capacity of 144 Btu/lb, high specific heat, high density, safety, and appropriate fusion temperature have proven desirable for many typical HVAC cooling applications.

Water has a very stable melting point of 32°F at sea level. Under some conditions, supercooling can depress the initial freezing point by 2 to 5°F, but impurities found in potable water, random disturbances, minor vibrations, surface interactions, or intentional agitation are generally sufficient to initiate nucleation of ice crystals. Supercooling most often occurs during an initial reduction of the liquid water temperature below 32°F. Residual ice reduces or eliminates the supercooling tendency for subsequent ice-making periods. The amount of supercooling, if experienced at all, is typically 2 or 3°F, and the phase-change temperature rapidly returns to 32°F immediately after this initial nucleation period. With relatively pure water that is isolated from any external influence, a proprietary agent may be used to induce nucleation.

Water slightly decreases in density below 39°F and expands by about 9% on freezing. This expansion is often used as an indicator of ice inventory where the ice remains completely submerged, such as with the ice-on-coil systems or ice-harvesting systems. If the ice is allowed to float in liquid water, the liquid level will remain constant as ice is frozen or melted. Ice slightly increases in density below the freezing temperature, but this is of little interest in storage systems, which all operate close to the phase-change temperature, and the variation is minor.

Many ice storage technologies use secondary coolants for heat transfer. This allows use of standard chillers, including centrifugals, for ice building and simplifies the application of the technology to typical chilled-water cooling systems. Common secondary coolants have well-documented properties and provide reliable freeze and corrosion protection when properly maintained and installed. The

proper concentration for the coolant is selected to provide a freeze point well below the lowest expected coolant temperature. This temperature is determined by the heat transfer characteristics of the storage device, flow rates, and chiller capacity.

Internal Melt Ice-On-Coil

Internal-melt ice-on-coil thermal storage devices circulate a secondary coolant or refrigerant through a tubular heat exchanger that is submersed in a cylindrical or rectangular tank of water. The phase-change water remains in the tank; both charging (ice making) and discharging (ice melting) are accomplished by circulating the secondary heat transfer fluid. Ice forms on the heat exchanger tubes during charging, and melts from the inside out (hence the term internal-melt) during discharging.

Internal-melt storage devices may be provided as complete, modular, factory-assembled units, or may consist of field-erected tanks equipped with prefabricated heat exchangers. Most current designs use secondary coolants (e.g., 25% ethylene glycol/75% water) as the heat transfer fluid.

Storage devices using refrigerant as the heat transfer fluid have also been developed for applications typically served by direct expansion equipment, such as residential and small commercial installations. However, these devices have not achieved wide commercial acceptance to date.

Storage device manufacturers typically provide performance data, including at least the average and final charging temperatures as a function of charging rate and flow. The average temperature is useful for selecting chiller capacity and estimating energy consumption. The lowest anticipated temperature is needed to establish chiller protection settings, specify coolant freeze protection requirements, and verify the capabilities of chiller selections, which is particularly important for centrifugal chillers. Glycols are currently the most commonly used secondary coolants, and design practices are conventional, with no exceptional material limitations other than the exclusion of galvanized steel for surfaces in contact with the heat transfer fluid. Proper application of some secondary coolants is addressed in Chapter 4 of the 2006 *ASHRAE Handbook—Refrigeration*.

The tubular heat exchanger is typically constructed of polyethylene or polypropylene plastic, or galvanized steel. Refrigerant-based systems may use copper. The heat exchanger typically occupies about 10% of the tank volume. Tube spacing is generally closer than in external-melt heat exchangers to compensate for the indirect heat exchange and the gradual development of a liquid annulus in the discharge mode. There is no need to maintain a liquid channel between individual tubes. The entire water volume between heat exchanger tubes is frozen. Approximately 9% of the tank volume, all above the heat exchanger, is reserved for expansion of the water as it freezes. Heat exchange surface does not usually extend into this expansion volume. If water is frozen in this area of the tank, subsequent melting may result in ice remaining in the expansion area, with voids forming around the heat exchange surfaces below. Some manufacturers provide means to prevent this possibility. Because the heat exchanger is prevented from floating, structurally or by its own weight, the rise in water level is proportional to the ice inventory. Level sensors can provide inventory information to the automatic control and/or energy management systems.

Several combinations of tanks and heat exchangers are available for secondary coolant systems. Cylindrical plastic tanks provide a combination of structure, water containment, and corrosion protection, and use a polyolefin heat exchanger, typically formed into a spiral configuration to conform to the tank shape. Structural steel tanks are usually rectangular; water containment can be achieved with either a metal or flexible liner. Steel tanks are often hot-dip galvanized for corrosion protection, and can use either galvanized steel or polyolefin heat exchangers.

Some care is required in the design of external piping because these are often modular systems, sometimes with large numbers of individual tanks arrayed in a variety of patterns. Reverse-return piping is often used to simplify balancing.

An important characteristic of the internal-melt design is the relationship between the charging and discharging processes (Figure 5). During discharge, ice in contact with the heat exchanger is melted first. Initial discharge rates can be very high, and initial available temperatures approach the phase-change temperature. However, as ice melts, an annulus of water develops between the heat exchanger and ice surfaces. This results in variable performance for the internal-melt design. Manufacturers have developed various methods of incorporating the effect of ice inventory levels in product performance descriptions. The temperature of coolant leaving the storage device varies with flow rate, supply temperature, and ice inventory. A mixing or diverting valve is often included to automatically adjust flow through the storage device, controlling both the leaving temperature and discharge rate. Because the storage flow can be completely independent of the chiller flow, cooling load can be imposed on either component in any desired proportion, allowing the designer to optimize discharge of storage for a particular utility rate and building load.

When the internal-melt system returns to ice-making (charging) mode, ice first forms directly on the heat exchanger surface and gradually accumulates, perhaps to a point where it joins with ice remaining from previous charges. Chilled-coolant temperatures are always at their most efficient levels for every ice-building period, and every charge can be carried to completion without penalty. There is usually no benefit to limiting the amount of ice produced, so the storage can be fully charged every night. Because the internal storage temperature is always at the phase-change temperature, standby losses are virtually independent of ice inventory. This simplifies control logic, maximizes efficiency, and eliminates the potential liabilities of predicting the next day's required storage. The close tube spacing needed for good discharge performance provides excellent ice-making performance, because the thermal conductivity of ice is about 3.5 times greater than that of liquid water. Although coolant temperatures depend on many factors, a typical charge cycle begins with coolant temperatures of 26°F entering storage and leaving near 32°F. For most of the charge period, the coolant temperatures are fairly stable, gradually diminishing but with an average supply temperature of approximately 24°F. As the end of the charge mode nears, temperatures decrease at much faster rates to perhaps a minimum supply temperature of 22°F. The rapid temperature decrease at the end of the charge cycle is caused by the exhaustion of latent heat and the lower specific heat of ice compared to liquid water. Depending on system type, a full charge may be indicated by an inventory measurement or a final leaving temperature. The ice-making chiller or compressor is generally fully loaded throughout the ice-making period. Once the ice inventory is

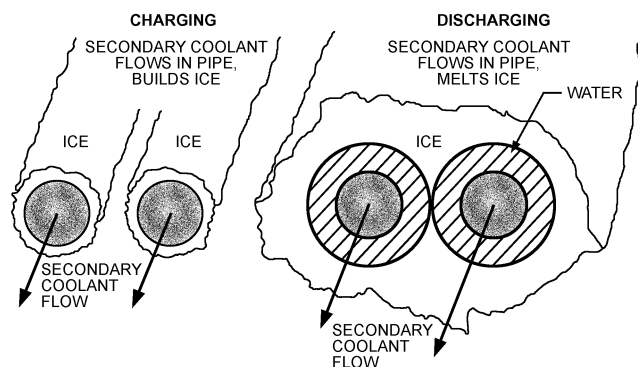

Fig. 5 Charge and Discharge of Internal-Melt Ice Storage

completely restored, ice-making chiller operation is terminated to prevent cycling the chiller in the ice-making mode.

External-Melt Ice-On-Coil

External-melt ice-on-coil thermal storage devices also consist of a tubular heat exchanger submersed in a cylindrical or rectangular tank of water. However, these devices circulate a secondary coolant through the tubes only for charging. Discharging is accomplished by circulating the water surrounding the heat exchanger. Ice melts from the outside in (Figure 6).

Traditional external-melt storage devices build ice by circulating cold liquid refrigerant through the heat exchangers. Although this approach is still commonly used in industrial applications, most external-melt systems for HVAC applications currently use glycol secondary coolants for charging. Water surrounding the heat exchanger is both the phase-change material and the heat transfer fluid for the discharge mode.

The charging heat transfer fluid is contained in a separate circuit from the water in the storage tank. Typically, a heat exchanger is installed between the two circuits to allow the same chiller to charge storage and help meet the cooling load directly. Some designs use separate chillers, or two separate evaporators served by the same compressor, to fulfill these functions. It is also possible to simply continue to circulate the heat transfer fluid through the storage heat exchanger to assist in direct cooling, but this approach requires that the refrigeration equipment continuously operate at subfreezing temperatures, incurring substantial capacity and efficiency penalties.

The individual galvanized steel heat exchangers or coils are assembled from a number of separate tubing circuits, and are usually stacked into large, site-fabricated concrete tanks. The tanks operate at atmospheric pressure, and additional measures may be needed to accommodate pressurized systems or elevation differences. The heat exchanger tube cross section can be circular or elliptical. Many different coil lengths, widths, and heights are available to conform to tank dimensions while simplifying coil connections, providing desired flow and pressure drop, and minimizing shipping costs.

Some form of agitation is needed to promote even ice building and melting, although continuous agitation may not be necessary during charging. Agitation is usually provided by distributing compressed air through plastic pipes under of each stack of heat exchangers.

The annular thickness of ice formed on the heat exchanger can vary widely, but an average of about 1.4 in. is a typical dimension used in published ratings. Proper ice-making control is particularly important for external melt systems. Ice-making temperatures are driven lower by excessive ice thickness. Because any new ice must be formed on the surface of existing ice, there is a benefit to limiting the ice thickness to what is needed for the following discharge period, while still ensuring an adequate storage inventory. Also, ice bridging must be prevented. A flow passage of liquid water must be

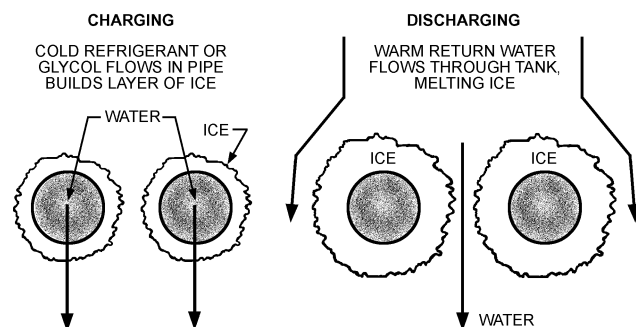

Fig. 6 Charge and Discharge of External-Melt Ice Storage

preserved between adjacent circuits of ice-building coils. Once flow is stopped or restricted, the ability to melt any ice can be significantly limited. Maintaining minimum ice inventory levels discourages ice bridging and promotes efficiency. Ice thickness controllers that sense a change in electrical conductivity are commonly used to control ice building, but other types are available. Manufacturers specify the number and location of thickness controllers. Continuous inventory measurement can be obtained by load cells or strain gages that measure the weight of the ice and steel coils, multiple thickness sensors, or by the change in water level, compensating for compressed air introduced into the tank.

Because the storage tank is at atmospheric pressure, some method may be needed to connect to a higher-pressure distribution water loop. The simplest methods are locating the tank at the highest elevation or adding a chilled-water heat exchanger. Adding pressure-sustaining valves on the tank return or regenerative turbine pumping are other possibilities.

The wider coil spacing typical of external-melt heat exchangers results in lower ice-making temperatures than in internal-melt systems. However, the direct-contact heat exchange in melting provides consistently low chilled-water temperatures of approximately 34°F and high discharge rate capacity. Separate flow circuits for the chiller and storage provide flexibility in assigning cooling load to each device in any desired proportion.

Encapsulated Ice

Encapsulated storage systems use a phase-change material, usually water, contained in relatively small polymeric vessels. A large number of these primary containers are placed in one or more tanks through which a secondary coolant circulates, alternately freezing and melting the water in the smaller containers. Standard chillers are typically used for ice production.

Currently available shapes are basically spherical and are factory-filled with water and a nucleating agent. The sealed containers are shipped to the installation site, where they are placed into the insulated tank, occupying perhaps 60% of the internal tank volume. There is usually no attempt to position the containers in their most compact configuration, instead relying on simple random packing. Some designs have additional surface features. One product uses a 4 in. diameter sphere with deformable depressions or concave hollows arrayed around the surface (Figure 7). Liquid water fills virtually the entire internal volume with the hollows in a depressed position. As water is frozen and expands, the depressions shift from concave to convex. They return to the original shape as the water

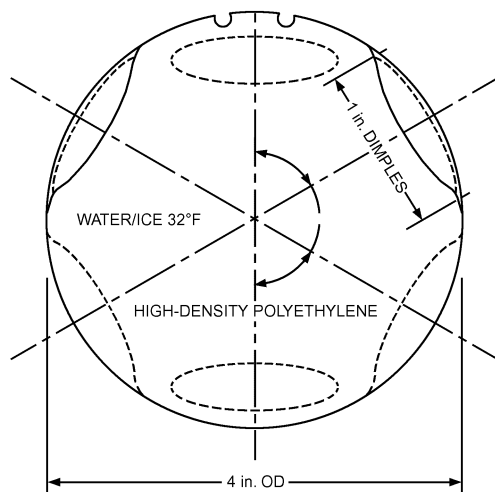

Fig. 7 Encapsulated Ice: Spherical Container
(Courtesy Cryogel)

melts. Besides accommodating water expansion, the variable-volume shape displaces the surrounding coolant. Displaced coolant can be used to measure ice inventory. For pressurized tanks, an additional expansion tank is included for this purpose; atmospheric tanks use the change in the coolant level for the primary tank as an inventory indicator. Other products use a more rigid shape and accommodate water expansion by leaving a void space within the container. Systems with rigid spheres use an energy balance method for inventory determination. Spheres with base diameters of 3 to 4 in. are available. The spheres are buoyant when surrounded by the secondary coolant. A third method, recently introduced, uses an internal collapsible chamber in a 5.4 in. sphere to accommodate expansion.

A wide variety of vertical and horizontal tanks, both pressurized and atmospheric, can be used. Internal headers are designed to distribute flow evenly throughout the storage volume. Some tanks can be completely buried. Atmospheric tanks must have a grid near the top of the tank to prevent flotation of the buoyant water-filled spheres. Although requiring more heat transfer fluid, the large cross-sectional flow area results in low pressure drops of approximately 7 to 9 feet.

Charging and discharging are similar to internal-melt ice-on-coil systems, using similar secondary coolants (e.g., 25% ethylene glycol/75% water). Flow typically proceeds through the tank from bottom to top. As with internal-melt systems, the temperature of coolant leaving the storage device varies with flow rate, supply temperature, and ice inventory. Because the shape and volume of the storage tanks varies over a wide range, manufacturers often provide performance data on a per-ton-hour basis.

Ice Harvesters

Ice-harvesting systems separate the formation of ice from its storage. Ice is generated by circulating 32°F water from the storage tank over the surfaces of plate or cylindrical evaporators arranged in vertical banks above the storage tank. Ice is typically formed to a thickness between 0.25 and 0.40 in. over a 10 to 30 min build cycle. The ice is harvested by a hot-gas defrost cycle, which melts the bond between the ice and the evaporator surface and allows the ice to drop into the storage tank below. Other types of ice harvesters separate ice from the evaporator surface mechanically.

Typically, the evaporators are grouped in sections that are defrosted individually so that the heat of rejection from active sections provides the energy for defrost. Tests done by Stovall (1991) indicate that, for a four-section plate ice harvester, the total heat of rejection is introduced into the evaporator during the defrost cycle. To maximize efficiency and ice production capacity, harvest time should be kept to a minimum.

Figure 8 shows an ice-harvesting schematic. Chilled water is pumped from the storage tank to the load and returned to the ice generator. A low-pressure recirculation pump is used to provide minimum flow for wetting the evaporator in ice-making mode. This system may be applied to load-leveling or load-shifting applications.

In load-leveling applications, ice is generated and the storage tank charged when there is little or no building load. When a building load is present, the return chilled water flows directly over the evaporator surface, and the ice generator functions either as a chiller or as both an ice generator and a chiller. The defrost cycle is energized if the return water temperature is low enough that the exit water from the evaporator is within a few degrees of freezing. When operated as a chiller only, maximum capacity and efficiency are obtained with minimum water flow and highest entering water temperature. In load-shifting applications, the compressors are turned off during the utility company's on-peak period, and ice water from the tank is circulated to the building load.

During the first part of the charge cycle, ice floats in the tank with about 10% of its volume above the water, and the water level remains constant. As ice continues to build, the ice comes to rest on

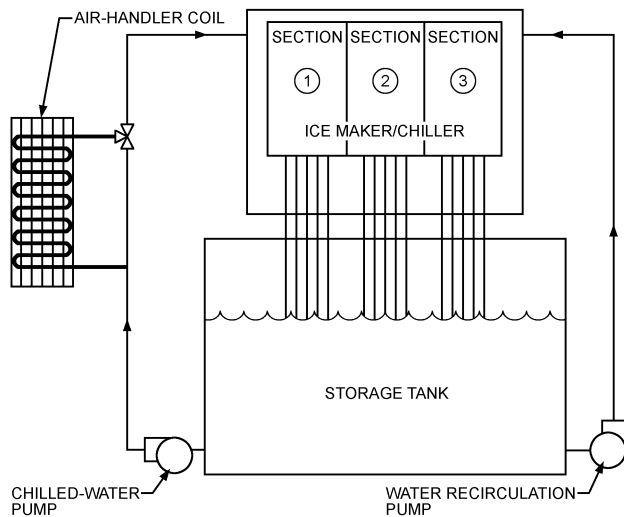

Fig. 8 Ice-Harvesting Schematic
(Courtesy Paul Mueller Company)

the bottom of the tank and builds up above the water level. The ice generation mode is terminated when the ice reaches the high ice level, as determined by a mechanical, optical, or electronic high-level sensor.

Because the ice is free to float in the tank, ice inventory cannot be determined by measuring the water level. Ice inventory may be tracked by maintaining a running energy balance calculation that monitors cooling discharged from and stored in the tank. The amount of cooling discharged can be determined by measuring chilled-water flow rate and supply and return temperatures. Cooling stored in the tank can be measured as the difference between the energy input to the compressor and the heat rejection from the condenser, or estimated based on compressor performance data and operating conditions. Ice inventory may also be tracked by measuring changes in water conductivity as the ice freezes and melts.

Although tank water level cannot be used to indicate the ice inventory during the storage cycle, the water level at the end of charging is a good indicator of system conditions. In systems with no gain or loss of water, the shutdown level should be consistent, and can be used as a back-up to determine when the tank is full for shutdown requirements. Conversely, a change in level at shutdown can indicate a water gain or loss.

Ice harvester systems usually use positive-displacement compressors with saturated suction temperatures usually between 18 and 22°F. The condensing temperature should be kept as low as possible to reduce energy consumption. The minimum allowable condensing temperature depends on the type of refrigeration used and the system's defrost characteristics. Several systems operating with evaporatively cooled condensers have operated with a compressor specific power consumption of 0.9 to 1.0 kW/ton (Knebel 1986, 1988; Knebel and Houston 1989).

Ice-harvesting systems can discharge stored cooling very quickly. Individual ice fragments are characteristically less than 6 by 6 by 0.25 in. and provide a large surface area per ton-hour of ice stored. When properly wetted, a 24 h charge of ice can be melted in less than 30 min for emergency cooling demands.

Ice harvesters typically use field-built concrete tanks or prefabricated steel tanks. The thermal storage capacity of usable ice that can be stored in a tank depends on its shape, location of the ice entrance to the tank, angle of repose of the ice (between 15 and 30°, depending on the shape of ice fragments), and water level in the tank. If the water level is high, voids occur under the water because of the ice's buoyancy. The ice harvester manufacturer may assist in tank design and piping distribution in the tank. Gute et al. (1995)

and Stewart et al. (1995a, 1995b) describe models for determining the amount of ice that can be stored in rectangular tanks and the discharge characteristics of various tank configurations. Dorgan and Elleson (1993) provide further information.

The tank may be completely or partially buried or installed above ground. A minimum of 2 in. of closed-cell insulation should be applied to the external surface. Because shifting ice creates strong dynamic forces, internal insulation should not be used except on the underside of the tank cover, and only very rugged components should be placed inside the tank. Exiting water distribution headers should be constructed of stainless steel or rugged plastic suitable for the cold temperatures encountered. PVC is not an acceptable material because of its extreme brittleness at the ice-water temperature.

As with field-built concrete tanks for other storage applications, close attention to design and construction is important to prevent leakage. An engineer familiar with concrete construction requirements should monitor each pour and check all water stops and pipe seals. Unlined tanks that do not leak can be built. If liners are used, the ice equipment suppliers will provide assistance in determining a suitable type, and the liner should be installed only by a qualified installer trained by the liner manufacturer.

The sizing and location of the ice openings are critical; all framed openings must be verified against the certified drawings before the concrete is poured.

An ice harvester is generally installed by setting in place a pre-packaged unit that includes the ice-making surface, refrigerant piping, refrigeration equipment, and, in some cases, heat rejection equipment and prewired controls. To ensure proper ice harvesting, the unit must be properly positioned relative to the ice drop opening. The internal piping is not normally insulated, so the drop opening should extend under the piping so condensate drops directly into the tank. A grating below the piping is desirable. To prevent air or water leakage, gasketing and caulking must be installed in accordance with the manufacturer's instructions. External piping and power and control wiring are required to complete the installation.

Ice Slurry Systems

Ice slurry is a suspension of ice crystals in liquid. An ice slurry system has the advantage of separating production of ice from its storage without the control complexity and efficiency losses associated with the ice harvester's defrost cycle. Slurries also offer the possibility of increased energy transport density by circulating the slurry itself, rather than just the circulating secondary liquid. However, a heat exchanger is usually used to separate the storage tank flow from the cooling load distribution loop. Like harvesters, slurry systems have very high discharge rates and provide coolant consistently close to the phase-change temperature.

In general, the working fluid's liquid state consists of a solvent (water) and a solute such as glycol, sodium chloride, or calcium carbonate. Depending on the specific slurry technology, the initial solute concentration varies from 2% to over 10%, by mass. The solute depresses the freezing point of the water and buffers the production of ice crystals. Slurry generation begins by lowering the temperature of the working fluid to its initial freezing point. Upon further cooling, water begins to freeze out of the solution. As freezing progresses, the concentration of solute increases and the freezing point at which ice crystals are produced decreases. Ice/water slurries have been reported to have a porosity of 0.50 and typical storage densities of 2.92 ft³/ton-hour (Gute et al. 1995).

One design uses a 7% solution of propylene glycol that provides an initial freezing temperature of about 28°F. A final freezing point of 25°F indicates that a full charge has been reached and about 50% of the volume has been frozen. Ice is formed near the inside surfaces of multiple cylinders of the orbital rod evaporator. Rotating rods travel along the inner evaporator surfaces, creating an agitated flow that enhances heat transfer and prevents adhesion of ice crystals. The compliant method of connecting the rod prevents damage in the

event of evaporator freeze-up. This arrangement reduces or eliminates the need for a defrost cycle, but adds mechanical components. The evaporators are typically arranged in vertical banks above the storage tank, and the slurry can also be pumped into an adjoining tank.

Other Phase-Change Materials

Water now dominates the market as the storage material for HVAC applications, but industrial or commercial processes sometimes require coolant temperatures that are not possible using plain water. A substantial amount of effort has been invested in the development of materials that would freeze above 32°F and still provide appropriate temperatures in the discharge mode. There are currently no commercially available systems using these materials. Phase-change materials with fusion temperatures above 32°F were usually inorganic salt hydrates that had high anhydrous salt fractions and limited latent heat capacities.

Materials with fusion temperatures below 32°F are more practical to develop and apply. These are often true salt eutectics and typically require lower percentages of the anhydrous components than materials with fusion temperatures above 32°F. Container geometry, or some chemical or mechanical means, prevents eventual stratification of components. Because these materials have salt constituents, they are more corrosive than plain water and are currently only available in encapsulated or all-plastic internal-melt ice-on-coil devices. The latent heat capacities for these materials are usually close to the volumetric heat capacities available from plain water. Supercooling is frequently associated with eutectics and hydrates and appropriate nucleating agents are often added to the material.

Unfortunately, storage at subfreezing temperatures cannot be achieved by adding a freeze depressant, such as ethylene glycol, to water. Unless the additive exists at a eutectic concentration, only the initial freezing point is affected, with the temperature gradually decreasing as the freezing process continues (see the section on Ice Slurry Systems). In most cases, the loss in volumetric heat capacity for a useful range of storage charge and discharge temperatures makes this an impractical solution.

HEAT STORAGE TECHNOLOGY

The most common current application of heat storage is in electrically charged, thermally discharged storage devices used for service water heating and space heating. Thermal storage systems for space heating can be classified as brick storage heaters (electric thermal storage or ETS heaters), water storage heaters, or radiant floor heating systems. Other applications include solar space and water heating, and thermally charged water storage tanks.

The choice of storage medium generally depends on the type of heating system. Air heaters use brick as the storage medium, whereas water heaters may use water or a PCM. Combination brick and hydronic systems use brick for the storage medium and transfer the heat to water as needed.

Solar space and water heating systems use rock beds, water tanks, or PCMs to store heat. Various applications are described in Chapter 33 of the 2004 *ASHRAE Handbook—HVAC Systems and Equipment*.

Thermally charged hot-water storage tanks are similar in design to the cool storage tanks described in the section on Storage of Heat in Cool Storage Units. Many are also used for cooling. Unlike off-peak cooling, off-peak heating seldom reduces the size of the heating plant or the utility bill (except in the case of collecting waste heat, such as applications associated with industrial processes or a turbine generator). The size of a storage tank used for both heating and cooling is based more on cooling than on heating for lowest life-cycle cost, except in some residential applications.

Sizing Heat Storage Systems

For electrically charged devices that use a solid mass as the storage medium, equipment size is typically specified by the nominal power rating (to the nearest kilowatt) of the internal heating elements. The nominal storage capacity is taken as the amount of energy supplied during an 8 h charge. For example, a 5 kW heater would have a nominal storage capacity of 40 kWh. ASHRAE *Standard 94.2* describes methods for testing these devices. If multiple charge/off-peak periods are available during a 24 h period, an alternative method that considers not only the nominal power rating, but also fan discharge rate and storage capacity, yields a more accurate estimate of equipment size. Consult the equipment manufacturer for more information on calculating the capacity of these devices.

A rational design procedure requires an hourly simulation of the design heat load and a known discharge capacity of the storage device. The first criterion for satisfactory performance is that the discharge rate must be no less than the design heating load at any hour. During the off-peak period, energy is added to storage at the rate determined by the connected load of the resistance elements less the design heating load. The second criterion for satisfactory performance is that energy added to storage during one day's off-peak period is sufficient to meet the total load for the entire 24 h.

A simplified procedure is recommended by Hersh et al. (1982) for typical residential designs. For each zone of the building, the design heat loss is calculated in the usual manner and multiplied by the selected sizing factor. The resulting value (rounded to the next kilowatt) is the required storage heater capacity. Sizing factors in the United States range from 2.0 to 2.5 for an 8 h charge period and from 1.6 to 2.0 for a 10 h charge period. If multiple off-peak periods occur during a 24 h period, this method may not accurately reflect equipment sizing. The designer should consult the manufacturer for specific sizing information based on on-peak and off-peak hours available. [Figure 9](#) shows a typical sizing factor selection graph for an application that has a single charging time block per day.

Service Water Heating

The tank-equipped service water heater, which is the standard residential water heater in North America, is a thermal storage device, and some electric utilities provide incentives for off-peak water heating. To meet that requirement, the heater is equipped with

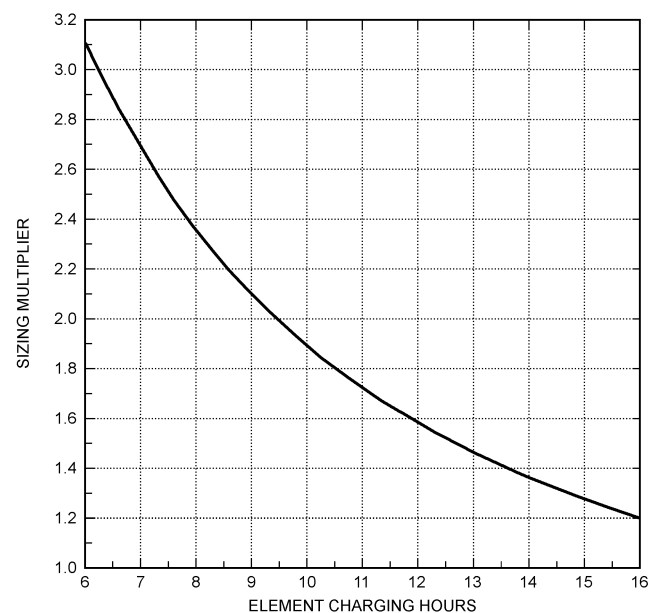

Fig. 9 Representative Sizing Factor Selection Graph for Residential Storage Heaters

a control system that is activated by a clock or by a signal directly from the electric utility to curtail power use during peak demand. An off-peak water heater generally requires a larger tank than a conventional water heater.

An alternative system of off-peak water heating consists of two tanks connected in series, with the hot-water outlet of the first tank supplying water to the second tank (ORNL 1985). This arrangement minimizes mixing of hot and cold water in the second tank. Tests performed on this configuration show that it can supply 80 to 85% of rated capacity at suitable thermal temperatures, compared to 70% for a single-tank configuration. The wiring for the heating elements in the two tanks may have to be modified to accommodate the dual-tank configuration.

Brick Storage (ETS) Heaters

Brick storage heaters [commonly called electric thermal storage heaters (ETS)] are electrically charged and store heat during off-peak times. In this storage device, air circulates through a hot brick cavity and then discharges into the area in which heat is desired. The ceramic brick has a very dense magnetite or magnesite composition. The brick’s high density and ability to store heat at a high temperature gives the heater a larger thermal storage capacity. Ceramic brick can be heated to approximately 1400°F during off-peak hours by resistance heating elements. Space requirements for brick storage heaters are usually much less than for other heat storage media.

Figure 10 shows the operating characteristics of an electrically charged room storage heater. Curve 1 represents theoretical performance with no discharge. In reality, radiation and convection from the exterior surface of the device continually supplies heat to the room during charging as well. Curve 2 shows this static discharge. When the thermostat calls for heat, the internal fan operates. The resulting faster dynamic discharge corresponds to curves 3 and 4. Because the heating elements of electrically charged room storage heaters are energized only during off-peak periods, they must store the total daily heating requirement during this period. The dynamic and static charging and discharging rates vary by equipment manufacturer.

The four types of brick storage heaters currently available are room storage heaters (room units), heat pump boosters, central furnaces, and radiant hydronic (brick to water).

Room Storage Heaters (Room Units). Room storage heaters (commonly called room units) have magnetite or magnesite brick cores encased in shallow metal cabinets (Figure 11). The core can be heated to 1400°F during off-peak hours by resistance heating elements located throughout the cabinet. Room units are generally small heaters that are placed in a particular area or room. These heaters have well-insulated storage cavities, which help retain the heat in

the brick cavity. Although the brick inside the units gets very hot, the outside of the heater is relatively cool, with surface temperatures generally below 165°F. Storage heaters are discharged by natural convection, radiation, and conduction (static heaters) or, more commonly, by a fan. Air flowing through the core is mixed with room air to limit the outlet air temperature to a comfortable range.

Storage capacities range from 13.5 to 60 kWh. Inputs range from 0.8 to 10.8 kW. In the United States, 120, 208, 240, and 277 V units are commonly available. The 120 V model is useful for heating smaller areas or in geographical areas with moderate heating days. Room storage heaters are used in residential and commercial applications, including motels, hotels, apartments, churches, courthouses, and offices. Systems are used for both new construction and retrofit applications. A common commercial application is replacement of an aging boiler or hot-water heating system.

Operation is relatively simple. When a room thermostat calls for heat, fans in the lower section of the room unit discharge air through the ceramic brick core and into the room. Depending on the charge level of the brick core, a small amount of radiant heat may also be delivered from the surface of the unit. The amount of heat stored in the brick core of the unit can be regulated either manually or automatically in relation to the outside temperature or the known or estimated space requirements.

These units fully charge in about 7 h (Figure 12), and they can be fully depleted in as little as 5 h. The equipment retains heat for up to 72 h, if it has no fan discharge (Figure 13).

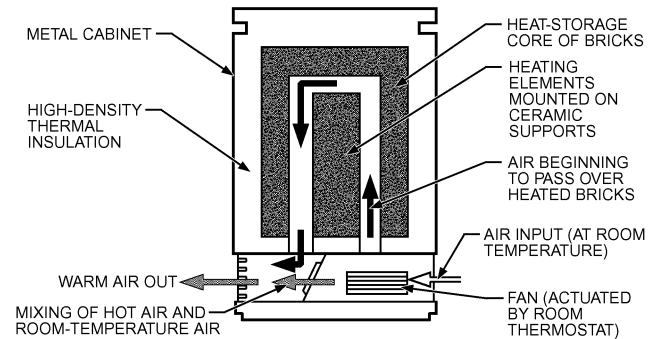

Fig. 11 Room Storage Heater
(Courtesy Steffes Corporation)

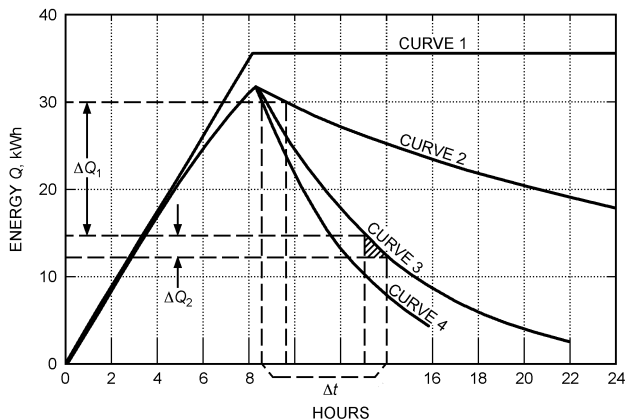

Fig. 10 Typical Storage Heater Performance Characteristics
(Hersh et al. 1982)

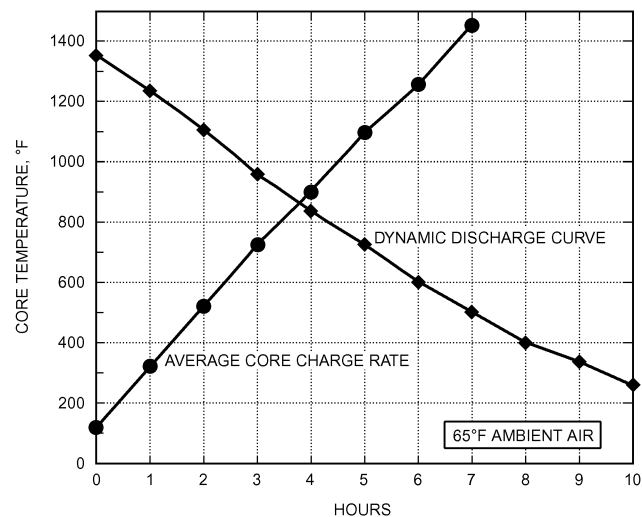

Fig. 12 Room Storage Heater Dynamic Discharge and Charge Curves

Choosing the appropriate size of room unit(s) depends on the length of the applicable on-peak and off-peak periods, local climate, and heat loss of the area or space. The designer must follow generally accepted practices for calculating design load or heat loss rate to ensure a properly functioning system that delivers satisfactory results. This equipment is generally configured according to one of the following two concepts:

Whole-House Concept. Under this strategy, room units are placed throughout the home. Units are sized according to a room-by-room heat loss calculation. This method is used in areas with long on-peak periods, generally 12 h or more.

Warm-Room Concept. Under this strategy, one or two room units are used as the primary heating source during on-peak periods. Units are placed in the area most often occupied (main area). Adjacent areas generally are kept cooler and have no operable heating source during the on-peak period; however, some heat migrates from the warmer main area.

When determining the heat loss of the main area, an additional sizing factor of approximately 25% should be added to allow for migration of heat to adjacent areas. Under the warm-room concept, sizing factors vary, depending on the rate structure of the power company and equipment performance under those conditions. Consult the equipment manufacturer for specific sizing information.

The warm-room concept is the most common method used by power companies for their load management and off-peak marketing programs. It is successful in areas that have a small number of consecutive hours of control (generally less than 12 h of on-peak time), or have a midday block of off-peak time during which the equipment can recharge. The advantage of the warm-room concept is that it requires smaller equipment and fewer heating units than the whole-house concept, thereby reducing system cost.

Heat Pump Boosters. Air-to-air heat pumps generally perform well when outside temperatures are relatively warm; however, as the outside temperature decreases, the efficiency, output capacity, and supply air temperature from a heat pump also decline. When the output of the heat pump drops below the heat loss of the structure, supplemental heat, typically from an electric resistance unit, must be added to maintain comfort. To eliminate the use of direct electric resistance heat during on-peak periods, storage heaters, such as the heat pump boosters (HPBs), can supplement the output of a heat pump. Additionally, the HPB monitors supply air temperatures and adds heat to the supply air as needed to maintain comfortable delivery air temperature at all times. The HPB can also be used as a

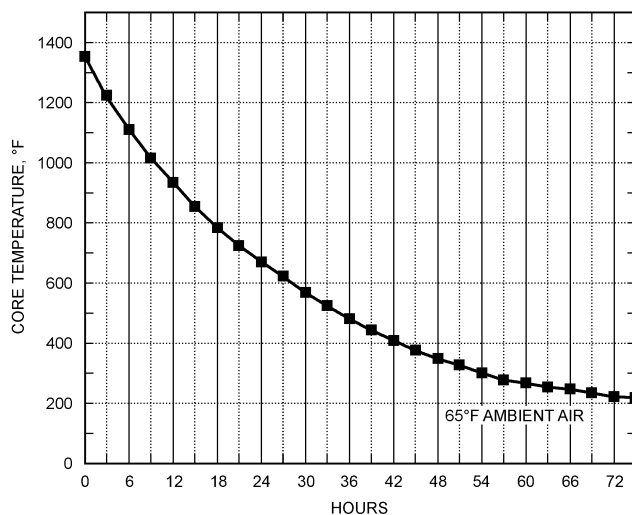

Fig. 13 Static Discharge from Room Storage Heater

booster for stand-alone forced-air furnaces or to back up electric or fossil fuel equipment in dual-fuel programs.

Core charging of the HPB is regulated automatically based on outdoor temperature. The brick storage core is well insulated so radiant or static heat discharge is minimal. Common residential equipment input power ratings range from 14 to 46 kW. Storage capacities range from 86 to 240 kWh. Larger commercial and industrial sizes have input ratings of 53 to 160 kW and storage capacities of up to 960 kWh.

Central Furnace. A central storage furnace is a forced-air heat storage product for residential, commercial, and industrial applications. These units are available with input ratings ranging from 14 to 46 kW. Storage capacities range from 86 to 960 kWh.

Radiant Hydronic Heaters. A ceramic brick storage system is available that uses an air-to-water heat exchanger to transfer heat from the storage system to a water loop. The off-peak heated water can be used in conventional hot-water systems, including floor warming (radiant floors), hydronic baseboards, hot-water radiators, indirect domestic hot-water heating, etc. An air handler can be added to these systems to achieve hydronic and forced-air heating from the same unit. In commercial and industrial applications, these systems can be used to preheat incoming fresh air in makeup air systems. These units are available in input ratings ranging from 20 to 46 kW with storage capacities from 120 to 240 kWh.

Pressurized Water Storage Heaters

This storage device consists of an insulated cylindrical steel tank containing immersion electrical resistance elements near the bottom of the tank and a water-to-water heat exchanger near the top (Figure 14). During off-peak periods, the resistance elements are sequentially energized until the storage water reaches a maximum temperature of 280°F, corresponding to 50 psig. The ASME Boiler Code considers such vessels unfired pressure vessels, so they are not required to meet the provisions for fired vessels. The heaters are controlled by a pressure sensor, which minimizes problems that could be caused by unequal temperature distribution. A thermal controller gives high-limit temperature protection. Heat is withdrawn from storage by running service water through the heat exchangers and a tempering device that controls the output temperature to a predetermined level. The storage capacity of the device is the sensible heat of water between 10°F above the desired output water temperature and 280°F. The output water can be used for space heating or service hot water. The water in the storage tank is permanently treated and sealed, requires no makeup, and does not interact with the service water.

In most applications, electrically charged pressurized water storage tanks must be able to be recharged during the off-peak period to meet the full daily heating requirement, while supplying heat to

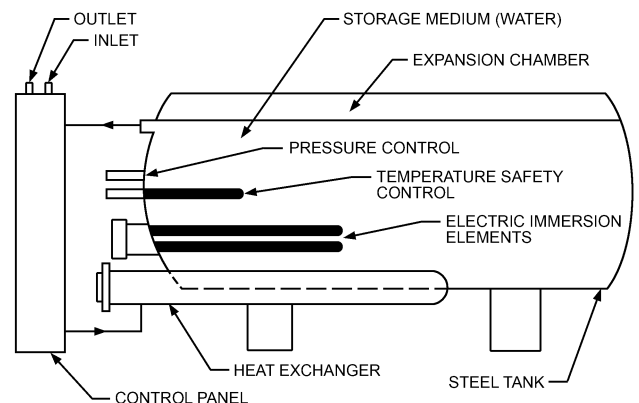

Fig. 14 Pressurized Water Heater

meet the load during the on-peak period. The heat exchanger design allows a constant discharge rate, which does not decrease near the end of the cycle.

Underfloor Heat Storage

This storage method typically uses electric resistance cables or hydronic tubing buried in a bed of sand 1 to 3 ft below the concrete floor of a building. Underfloor heat storage is suitable for single-story buildings, such as residences, churches, offices, factories, and warehouses. An underfloor storage heater acts as a flywheel. Although the unit is charged only during the nightly off-peak period, it maintains the top of the floor slab at a constant temperature slightly higher than the desired space temperature. Because the cables spread heat in all directions, they do not have to cover the entire slab area. For most buildings, a cable or tube location of 18 in. below the floor elevation is optimum. The sand bed should be insulated along its perimeter with 2 in. of rigid, closed-cell foam insulation, to a depth of 4 ft (Figure 15). Even with a well-designed and well-constructed underfloor storage, 10% or more of the input heat may be lost to the ground.

Building Mass Thermal Storage

The thermal storage capabilities inherent in the mass of a building structure can have a significant effect on the temperature in the space as well as on the performance and operation of the HVAC system. Effective use of structural mass for thermal storage reduces building energy consumption and reduces and delays peak heating and cooling loads (Braun 1990). In some cases, it improves comfort (Morris et al. 1994; Simmonds 1991). Perhaps the best-known use of thermal mass to reduce energy consumption is in buildings that include passive solar techniques (Balcomb 1983).

Cooling energy can be reduced by precooling the structure at night using ventilation air. Andresen and Brandemuehl (1992), Braun (1990), and Ruud et al. (1990) suggested that mechanical precooling of a building can reduce and delay peak cooling demand; Simmonds (1991) suggested that the correct building configuration may even eliminate the need for a cooling plant. Mechanical precooling may require more energy use; however, the reduction in electrical demand costs may give lower overall energy costs. Moreover, the installed capacity of air-conditioning equipment may also be reduced, providing lower installation costs. Braun (2003) provided an overview of related research, and found that (1) there is a tremendous opportunity for reductions in on-peak energy and peak

demand, and (2) the savings potential is very sensitive to the utility rates, building and plant characteristics, weather conditions, and occupancy schedule.

The potential energy cost savings from precooling depends on the control strategies used to charge and discharge the building thermal mass. Several studies of building pre-cooling controls have been reported (Braun 1990; Braun et al. 2001; Conniff 1991; Keeney and Braun 1996; Morgan and Krarti 2006; Morris et al. 1994; Rabl and Norford 1991; and Ruud et al. 1990). Precooling’s potential in reducing electric energy costs is generally well documented. Reported investigations have shown that energy costs have been reduced by 10 to 50% under dynamic rates, and on-peak demand reduced by 10 to 35%, just by precooling building thermal mass.

In particular, Morgan and Krarti (2006) performed both simulation analyses and field testing to evaluate various precooling strategies. They found that the energy cost savings associated with precooling thermal mass depend on several factors, including thermal mass level, climate, and utility rate. For time-of-use utility rates, they found that energy cost savings are affected by the ratio of on-peak to off-peak demand charges R_d , as well as ratio of on-peak to off-peak energy charges R_e . Figures 16 and 17 show the variation of the annual energy cost savings from 4 h precooling an office building with heavy mass as a function of R_d and R_e , respectively.

Henze et al. (2004, 2005) and Kintner-Meyer and Emery (1995) evaluated the combined use of both building thermal mass (passive TES) and ice or chilled-water storage tanks (active TES), a load management strategy to shift on-peak building HVAC cooling load to off-peak time. Thermal mass use can be considered incidental and not be considered in the heating or cooling design, or it may be intentional and form an integral part of the design. Effective use of building structural mass for thermal energy storage depends on factors such as (1) physical characteristics of the structure, (2) dynamic

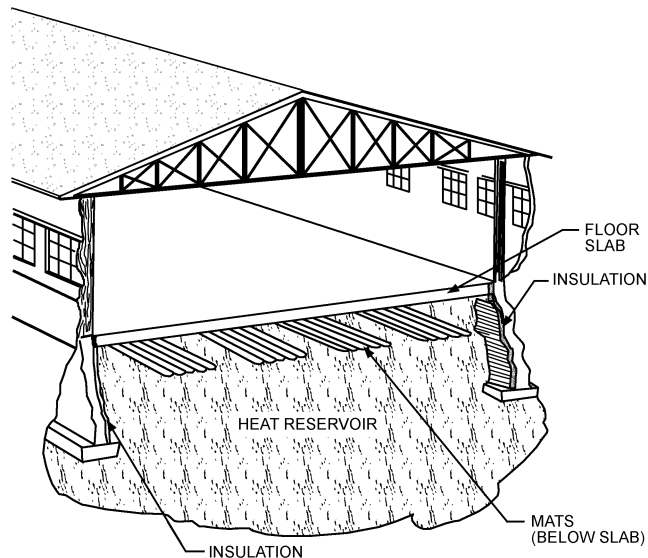

Fig. 15 Underfloor Heat Storage

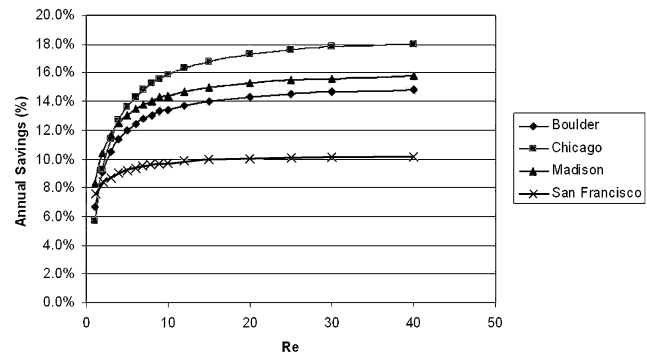

Fig. 16 Annual Energy Cost Savings from Precooling, Relative to Conventional Controls, as Function of R_e

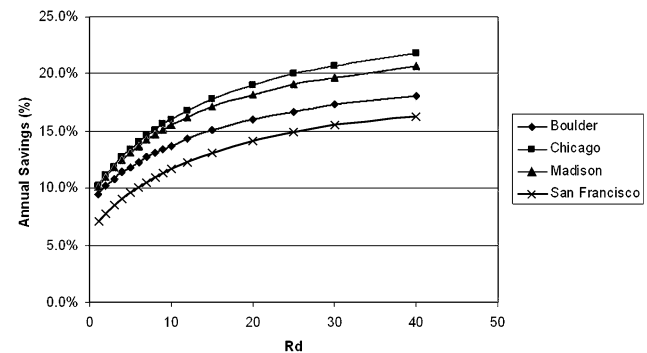

Fig. 17 Annual Energy Cost Savings from Precooling, Relative to Conventional Controls, as Function of R_d

nature of the building loads, (3) coupling between the building mass and zone air (Akbari et al. 1986), and (4) strategies for charging and discharging the stored thermal energy. Some buildings, such as frame buildings with no interior mass, are inappropriate for this type of thermal storage. Many other physical characteristics of a building or an individual zone, such as carpeting, ceiling plenums, interior partitions, and furnishings, affect the quantity of thermal storage and the coupling of the building mass with zone air.

Incidental Thermal Mass Effects. A greater amount of thermal energy is required to bring a room in a heavyweight building to a suitable condition before occupancy than for a similarly sized lightweight building. Therefore, the system must either start conditioning the spaces earlier or operate at a greater-capacity output. During the occupied period, a heavyweight building requires a smaller output, because a larger proportion of heat gains or losses is absorbed by the thermal mass.

Advantage can be taken of these effects if low-cost electrical energy is available during the night and the air-conditioning system can be operated during this period to precool the building mass. This can reduce both the peak electric demand and total energy required during the following day (Braun 1990; Morgan and Krarti 2006), but it may not always be energy efficient.

Intentional Thermal Mass Effects. To make best use of thermal mass, the building should be designed with this objective in mind. Intentional use of the thermal mass can be either passive or active. Passive solar heating is a common application that uses the thermal mass of the building to provide warmth outside the sunlit period. This effect is discussed in further detail in [Chapter 33](#). Passive cooling applies the same principles to limit the temperature rise during the day. In some climate zones, the spaces can be naturally ventilated overnight to remove surplus heat from the building mass. This technique works well in moderate climates with a wide diurnal temperature swing and low relative humidity, but it is limited by the lack of control over the cooling rate.

Active systems overcome some of the disadvantages of passive systems by using (1) mechanical power to help heat and cool the building and (2) appropriate controls to limit output during the release or discharge period.

Storage Charging and Discharging

The building mass can be charged (cooled or warmed) either indirectly or directly. Indirect charging is usually accomplished by heating or cooling either the bounded space or an adjacent void. Almost all passive and some active cooling systems are charged by cooling the space overnight (Arnold 1978). Most indirect active systems charge by ventilating the void beneath a raised floor (Crane 1991; Herman 1980). Where this is an intermediate floor, cooling can be radiated into the space below and convected from the floor void the following day. By varying the rate of ventilation through the floor void, the rate of storage discharge can be controlled. Proprietary floor slabs commonly have hollow cores (Anderson et al. 1979; Willis and Wilkins 1993). The cores are continuous, but when used for thermal storage, they are plugged at each end, and holes are drilled to provide the proper airflow. Charging is carried out by circulating cool or warm air through the hollow cores and exhausting it into the room. Fan discharge air can be controlled by a ducted switching unit that directs air through the slab or directly into the space.

A directly charged slab, used commonly for heating and occasionally for cooling, can be constructed with an embedded hydronic coil. Refer to Chapter 6 in the 2004 *ASHRAE Handbook—HVAC Systems and Equipment* for design details. The temperature of the slab is only cycled 3 to 5°F to either side of the daily mean temperature of the slab. Consequently, the technique can use very-low-grade free cooling (approximately 66°F) (Meierhans 1993) or low-grade heat (approximately 82°F) rejected from condensers. In cooling applications the slab is used as a cool radiant ceiling, and for

warming it is usually a heated floor. Little control is necessary because of the small temperature differences and the high heat storage capacity of the slab.

The amount of heat stored in a slab equals the product of mass, specific heat, and temperature rise. The amount of heat available to the space depends on the rate at which heat can be transferred between the slab and the surrounding spaces. The combined radiant/convective heat transfer coefficient is generally quite low; for example, a typical value for room surfaces is 1.4 Btu/h·ft²·°F.

Design Considerations

Many factors must be considered when an energy source is time dependent. The minimum temperature occurs just before dawn, which may be at the end of the off-peak period, and the optimum charge period may run into the working day. Beginning the charge earlier may be less expensive but also less energy efficient. In addition, energy stored in the building mass is neither isolated nor insulated, so some energy is lost during charging, and the amount of available free energy (cooler outside air when suitable and available) varies and must be balanced against the energy cost of mechanical power. As a result, there is a tradeoff that varies with time between the amount of free energy that can be stored and the power necessary for charging.

The cooling capacity is, in effect, embedded in the building thermal mass; therefore conventional techniques of assessing the peak load cannot be used. Detailed weather records that show peaks over several 3 to 5 day periods, as well as data on either side of the peaks, should be examined to ensure that (1) the temperature at which the building fabric is assumed to be before the peak period is realistic and (2) the consequences of running with exhausted storage after the peak period are considered. This level of analysis can only be carried out effectively using a dynamic simulation program. Experience has shown that these programs should be used with a degree of caution, and the results should be compared with both experience and intuition.

Factors Favoring Thermal Storage

Thermal storage is particularly attractive in situations where one or more of the following conditions are present:

New Investment in Chiller Plant Required. A key factor favoring thermal storage is whether the owner must invest in a conventional chiller system (new or an expansion) if thermal storage is not used. This typically occurs during (1) new construction, (2) facility expansions, and (3) chiller plant expansions and rehabs.

Thermal storage systems generally require smaller refrigerating equipment than nonstorage systems. Air and water distribution equipment may also be smaller, and electrical primary power distribution requirements may be significantly smaller. In many situations, the reduced cost of this equipment can partially, completely, or more than completely offset the cost of the thermal storage equipment (Andrepoint 2005; Andrepoint and Rice 2002), and the operating cost benefits of thermal storage are thereby achieved at a lower cost. For an existing plant that is to be expanded, the additional loads can often be met by thermal storage at a lower cost than adding new chillers, pumps, cooling towers, and mechanical room space (Andrepoint and Kohlenberg 2005).

Peak Load Higher Than Average Load. Because thermal storage systems are generally sized for the average expected load, they can provide significant equipment size reductions and cost savings for applications with high peak load spikes. Buildings such as churches, entertainment and sports facilities, convention centers, and some industrial processes can achieve particular benefits. In addition, most commercial and educational facilities also have load profiles conducive to thermal storage.

Favorable Utility Rates. Utility rates often include on-peak and off-peak schedules. On-peak demand and energy charges are higher than off-peak charges, reflecting the utility company's increased

cost of meeting high daytime power demands. Some rate schedules include a ratcheted demand charge, which normally bases the demand charge for the current month on the highest demand incurred during any of the previous 12 months. High demand charges and ratcheted rates, as well as large differences between on-peak and off-peak energy charges, favor the use of cool storage to reduce operating costs.

Real-time pricing structures, which substitute time-varying energy charges for the more prevalent demand/energy structure, are becoming more common. Real-time pricing structures that feature high daily price spikes of relatively short duration also favor the use of cool storage.

Owners with cool storage systems can sometimes negotiate more favorable electric rates from their energy suppliers based on their capability to reduce their electric load during certain peak electric demand periods.

In areas where the electricity supply is limited, thermal storage is attractive because it allows a building to be conditioned with a much lower electrical peak demand.

Back-Up or Redundant Cooling Desirable. A properly designed thermal storage system can easily be maintained over long periods and discharged quickly when needed.

Thermal storage can provide cooling if the emergency back-up power supply is sized to run just the pumps. Thermal storage can also reduce the size of a full back-up power supply, because of the reduced power of the thermal storage system compared to a traditional full chiller system.

Thermal storage in combination with conventional chiller(s) can provide a larger portion of the daytime cooling required if one chiller goes down. For example, in a typical traditional system with two chillers, each is sized for 50% of the load. In a thermal storage system with two chillers, with each sized for 25% of the peak load, and thermal storage, if one chiller breaks down there will be 25% capacity from the chiller plus 50% capacity from the thermal storage, for a total of 75% of full capacity. If the chiller remains out of service for an extended period of time, the one chiller can typically recharge more than half the thermal storage so the capacity available is always above 50%. In the nonstorage system, there would only be 50% capacity available.

Cold-Air Distribution Desirable. Cold-air distribution, with supply air temperatures below the traditional 55°F, allows smaller fans and ducts to cool the spaces, and the system can maintain a lower space humidity (Kirkpatrick and Elleson 1997). Thermal storage and cold-air distribution should be considered for applications that have limited space for fans and ducts, require increased capacity from existing fans and ducts, or require (or could benefit from) lower space relative humidity.

Storage for Fire Protection Beneficial. Chilled-water thermal storage can be configured to provide a fire-protection water supply at a much lower cost than installing separate systems by equipping the storage tank with fire nozzles (Holness 1992; Hussain and Peters 1992; Meckler 1992).

Environmental Benefits Sought. Thermal storage can provide environmental benefits related to reduced source energy use, decreased refrigerant charge, and improved efficiency of the energy supply.

Thermal storage systems can operate with lower energy use than comparable nonstorage systems for several reasons. Cool storage systems benefit from operating chillers at lower condensing temperatures during nighttime operation. Thermal storage provides the opportunity to run a heating or cooling plant at its peak efficiency during 100% of its operating period, for a much higher dynamic operating efficiency. Because equipment in a nonstorage system has to follow the building load profile, the majority of its operation is at part-load conditions, which, for most systems, is much less efficient. Thermal energy storage also enables the practical incorporation of other high-efficiency technologies such as cold-air

distribution and nighttime heat recovery. Several facilities have demonstrated site energy reductions with the application of thermal energy storage (Bahnfleth and Joyce 1994; Fiorino 1994; Goss et al. 1996).

Most thermal energy storage systems reduce the size of refrigerating equipment needed. Reduced refrigeration equipment size means less on-site refrigerant usage and lower probability of environmental problems caused by a leak.

In addition to the potential reduction in energy use at the building site, thermal storage systems can reduce source energy use and emissions at the generating plant. Typically, the base-load power generating equipment that generates most off-peak electricity is more efficient and less polluting than the peaking plants that are used to meet high daytime demand. Transmission and distribution losses are also lower when the supply networks are more lightly loaded and when ambient temperatures are lower. Because thermal storage systems shift the site energy use from on-peak to off-peak periods, the total source energy and power plant emissions required to deliver cooling to the facility will be lower (Gansler et al. 2001; Reindl et al. 1995). In addition, by reducing peak demand, thermal storage helps prevent or delay the need to construct additional power generation and transmission equipment.

Thermal storage also has beneficial effects on combined heat and power systems by matching the thermal and electric load profiles.

The U.S. Green Building Council's (USGBC) Leadership in Energy and Environmental Design (LEED) rating system seeks to encourage sustainable design. The system awards points for various sustainable design features, including reductions in annual energy cost compared to a standard reference building. Thermal storage is a good way for a building to reduce energy cost and comply with the LEED rating system, and has been used in many buildings that have received LEED certification.

Factors Discouraging Thermal Storage

Thermal storage may be difficult to justify economically if

- Cooling load profile is flat, with very little difference between the peak and average loads
- Available utility rates do not differ between night and day electrical costs
- Space is not available indoors or outdoors for thermal storage tank(s)

Note that even when one or more of these conditions are true, thermal storage may still be justified by the factors favoring thermal storage. In addition, thermal storage should be integrated into the initial cooling system design for it to achieve the greatest economic benefit for the owner and operator.

Typical Applications

Few applications are not suited to thermal storage. Particularly well suited to thermal storage are sports and entertainment facilities, convention centers, churches, airports, schools and universities, military bases, and office buildings, because they have widely varying loads. The average cooling load for these buildings is much lower than the peak load. In addition, using high temperature differentials for chilled-water and air distribution can significantly reduce construction costs, and decrease utility bills.

Health care facilities, data centers, and hotels having loads with only a slight variation between day and night may also be suited for thermal storage. Normally, the thermal storage should be sized to handle the variation in load, not the total load. Thermal storage can provide a steady supply temperature when rapid changes in operating or meeting room temperatures are required. High temperature differentials for chilled-water and air distribution can significantly reduce construction costs, and the lower electrical demand can also reduce the size of emergency back-up generators.

District Cooling Systems. District cooling systems benefit from thermal storage in several ways. The cost of the distribution system in district cooling applications is a large percentage of the total system cost. As a result, when higher temperature differentials available from thermal storage media are used, life-cycle costs can be lower by using smaller pipes, valves, pumps, heat exchangers, motors, starters, etc. Energy costs of chilled-water distribution are thereby reduced. Thermal storage can provide a steady supply temperature when rapid changes in load occur. The lower electrical demand may reduce the size of emergency back-up generators.

Furthermore, thermal storage may be used to increase the available cooling capacity of an existing chilled-water distribution system by providing cooler supply water. This modification has little effect on the distribution system itself (i.e., pumping and piping) during peak load, because the existing system flow rates and pressure drops do not change. During off-peak cooling load conditions, pumping energy costs can be greatly reduced, because the flow rate can be reduced proportionate to the reduced load.

Most storage tanks are open, so attention should be given to system hydraulics when connecting several plants to a common distribution network where storage tank water levels are at different elevations. Chapter 11 of the 2004 *ASHRAE Handbook—HVAC Systems and Equipment* has additional information on district systems and related topics.

Industrial/Process Cooling. Industrial refrigeration and process cooling typically require lower temperatures than environmental air conditioning. Applications such as vegetable hydrocooling, milk cooling, carcass spray-cooling, and storage room dehumidification can use cold water from an ice storage system. Lower temperatures for freezing food, storing frozen food, and so forth can be obtained by using a low-temperature sensible energy storage fluid, a low-temperature hydrated salt PCM charged and discharged by a secondary coolant, or a nonaqueous PCM such as CO₂.

Some of the advantages of cool storage may be particularly important for industrial refrigeration and process cooling applications. Cool storage can provide a steady supply temperature regardless of large, rapid changes in cooling load or return temperature. Charging equipment and discharging pumps can be placed on separate electrical service to economically provide cooling during a power failure or to take advantage of low, interruptible electric rates. Storage tanks can also be oversized to provide water for emergency cooling or fire fighting. Cooling can be extracted very quickly from a thermal storage system to satisfy a very large load and then be recharged slowly, using a small charging system. System design may be simplified when the load profile is determined by production scheduling rather than occupancy and outdoor temperatures.

Combustion Turbine Inlet Air Cooling. Cool storage can increase the capacity and efficiency of combustion turbines by precooling the inlet air. Oil- or gas-fired combustion turbines typically generate full rated output at an inlet air temperature of 59°F, and above rated output below 59°F. At higher inlet air temperatures, the density and thus the mass flow of air is reduced, decreasing the shaft power and fuel efficiency. Capacity and efficiency can be increased by precooling inlet combustion air with chilled-water coils or direct-contact cooling. The optimum inlet air temperature is typically in the range of 40 to 50°F, depending on the turbine model.

On a 100°F summer day, a combustion turbine driving a generator may lose up to 25% of its rated output. This drop in generator output occurs at the most inopportune time, when an electrical utility or industrial user is most in need of the additional electrical output available from combined cycle or peaking turbines. This lost capacity can be regained if the inlet air is artificially cooled (Andrepoint 1994; Ebeling et al. 1994; MacCracken 1994; Mackie 1994). Cool storage systems using chilled water or ice are well suited to this application because the cooling is generated and stored during off-peak periods, when demand for the generator output is lower, and the maximum net increase in generator capacity is

obtained by turning off the refrigeration compressor during peak demand periods, providing the added generator capacity at the time it is needed most (Andrepoint 2001; Cross et al. 1995; Liebendorfer and Andrepoint 2005). Some parasitic power is required to operate water pumps to use the stored cooling energy.

Although instantaneous cooling can also be used for inlet air precooling, this refrigeration equipment often uses 25 to 50% of the increased turbine power output. It is especially taxing because the maximum need occurs during times of highest cost for energy and lowest output of the direct cooling compressor, because of the higher ambient temperature. Cool storage systems can meet all or part of the load requirements for inlet air precooling. Evaporative coolers are also a simple and well-established technology for inlet air precooling, but they cannot deliver the low air temperatures available from refrigeration systems. Additional information can be found in the *Design Guide for Combustion Turbine Inlet Air Cooling Systems* (Stewart 1999).

Mission-Critical Operations. Thermal storage systems can be used for emergency back-up cooling during unplanned downtime of the chillers that serve mission-critical operations such as data processing centers. Such operations cannot tolerate even short periods of cooling interruptions. If a chiller serving one of these areas unexpectedly goes off-line, it will take at least 20 min to restart the chiller, during which time some kind of back-up cooling is required. Providing emergency back-up cooling with cool storage is typically more economical to install and operate than a redundant air-conditioning system.

SIZING COOL STORAGE SYSTEMS

A first step in sizing a cool storage system is to determine the amount of the design load to be met from storage. Proper sizing requires calculating a design load profile and determining the required chiller and storage capacity to meet the load profile.

Sizing Strategies

Cool storage systems can be sized for full or partial storage operation on the design day. A full storage, or load-shifting system, meets the entire design day on-peak cooling load from storage. A partial storage system meets a portion of the design day on-peak cooling load from storage, with the remainder of the load met by operating the chilling equipment. A load-leveling design is a partial storage approach that minimizes equipment size and storage capacity. The system operates with refrigeration equipment running at full capacity for 24 h to meet the design load profile. When the load is less than the chiller output, the excess cooling is stored. When the load exceeds the chiller capacity, the additional requirement is discharged from storage.

Calculating Load Profiles

An accurate calculation of the design load profile is important to the success of a cool storage design, for several reasons, such as the following:

- To determine the amount of storage capacity required, the total integrated cooling load must be known.
- To ensure that the storage capacity is available when it is needed, the timing of the loads must be known.
- To ensure that cool storage suppliers provide equipment with the appropriate performance, the load profile must be specified.

Knowledge of the cooling load is required for each hour of the storage cycle, which, for most systems, is a 24 h design day. A cool storage system based on an erroneous load calculation may be undersized and unable to meet the full load, or it may be oversized and unnecessarily expensive and inefficient. Note, however, that in some cases designers may intentionally specify excess capacity to provide for future load increases.

The shape of the load profile also affects the performance characteristics of storage systems. For example, many cool storage systems respond differently to a constant load than to a load that increases to a peak and then decreases to a lower level. Therefore, it is important to accurately calculate the load for each hour of the storage and discharge cycles to allow designing to the proper total and instantaneous capacities.

Calculating loads for storage systems is similar to that for nonstorage designs, except that all heat gains for the entire design day, on an hourly basis, must be considered.

Select design temperatures with care, based on the allowable number of hours that the load may exceed the system capacity. Note that system performance is dependent on the sequence of weather conditions as well as the peak daily condition. Colliver et al. (1998) developed design weather profiles for locations across North America, with design weather conditions for one, three, five, and seven consecutive days.

Establish accurate schedules of occupancy, lighting, and equipment use. For example, if equipment, such as computers, operates continuously, heat gains during unoccupied periods are significant. The schedules should account for any changes to occur in the foreseeable future.

Include all sources of heat in the conditioned space. Nearly all electric input to the building, as well as external heat gains from conduction and solar radiation, will eventually become a load on the cool storage system. Include reheat load when reheat is to be used and include heat gains from the surroundings to the storage tank. Gatley and Riticher (1985) present detailed lists of often-overlooked heat sources that can significantly affect the load profile.

Consider any pull-down loads, which accumulate when systems are shut down during unoccupied periods, and must be met during the first minutes or hours of system operation.

Use the expected relative humidity in the building to calculate latent heat gains from infiltration, especially if supply air temperatures are to be reduced.

Note that there are two types of design days for cool storage applications: the day with the maximum 1 h cooling load for the year, and the day with the maximum integrated load over a 24 h period. In some buildings, these two types of peaks will not occur on the same day. Systems must be sized to provide sufficient cooling capacity on the day with the highest integrated cooling load as well as the day with the highest hourly load.

Recognize that the calculated building load does not represent the chilled-water load on the central plant. To obtain the load profile for the cooling plant, the designer must consider the operation of the air and water distribution systems that are used to meet the loads. This analysis should include

- Control sequences for chilled water coils and space temperatures, including set points and throttling ranges
- Fan and duct heat gains
- Pump and piping heat gains
- Heat gains to the storage system from external conduction to the storage tank

Load calculations for cool storage systems are discussed further in the *Design Guide for Cool Thermal Storage* (Dorgan and Elleson 1993). General air-conditioning cooling load calculations are discussed in detail in Chapter 30 of the 2005 ASHRAE *Handbook—Fundamentals*.

When cool storage is to be installed in an existing facility, determining loads by direct measurement may be preferable to estimating the loads. Load data may be available from logs collected by the building automation system, from chiller logs maintained by operating personnel, or from on-site measurements made over a period of design or near-design weather conditions. Field measurements should be verified by comparison with reference instruments of known accuracy, energy balance calculations, or some other external

verification. Note that, if the load on an existing system exceeds the capacity of the existing equipment, measured loads will be limited by the equipment capacity and may not reflect the actual loads.

Sizing Equipment

Quick sizing formulas are available to estimate the chiller and storage capacities necessary to meet a given load profile. However, accurate evaluation of chiller performance and storage at the appropriate conditions for each hour of the design cooling cycle is required for proper sizing of equipment.

Unlike most air-conditioning and refrigeration equipment, cool storage devices have no sustained, steady-state operating condition at which equipment performance can be characterized using standard parameters. The *usable* storage capacity of a cool storage device may vary appreciably depending on the application (ARI *Guideline T*).

Usable capacity depends on the load profile and temperature requirements that the cool storage equipment must meet. Net usable capacity is typically not equal to, and in fact is nearly always less than, the nominal capacity. The designer must carry out an hourly analysis to determine the nominal storage capacity and discharging capacity required to meet a given load profile. Hourly analysis is also necessary to specify the thermal performance that cool storage equipment must provide.

Specifications for cool storage equipment must include the operating profile that the equipment is required to meet. (Omitting the operating profile from the cool storage specification is comparable to omitting the design chilled-water and condenser water temperatures from a chiller specification.) The design team must prepare an hourly operating profile to select the appropriate chiller and storage capacities to meet the load. The operating profile defines the system operating conditions each hour of the complete storage cycle. Most cool storage systems are designed for a one-day storage cycle, and the operating profile includes data for a 24 h period.

In addition to determining capacity requirements, designers use the hourly operating profile to

- Develop control sequences
- Define performance requirements that suppliers of storage equipment must meet and against which commissioners must validate actual performance
- Determine requirements for components such as pumps and heat exchangers
- Evaluate system performance after it is installed

The operating profile must include the following information for each hour of the storage cycle:

- Ambient dry- and wet-bulb temperatures
- Total system load
- Load met by chiller(s)
- Load met by storage equipment
- Fluid temperature(s) entering chiller(s)
- Fluid temperature(s) leaving chiller(s)
- Fluid flow rate to chiller(s)
- Fluid temperature(s) entering storage
- Fluid temperature(s) leaving storage
- Fluid flow rate to storage (charging mode)
- Fluid flow rate leaving storage (discharging mode)
- Fluid pressure drop through storage, chiller and piping system
- Total capacity (ton-hours) of usable stored cooling
- Maximum cooling capacity or electric demand for chilling equipment

The hourly operating profile should be developed using manufacturers' performance data for specific chiller and storage selections. Typically, designers must iterate between chiller data and storage data to determine the balance between the components. For example, the storage performance characteristics determine the

temperatures required to charge storage with a given chiller capacity. Chiller capacity varies with fluid flow rate and temperature entering the evaporator, and with condensing temperature.

The capacity and performance of existing chillers and cooling towers may not be equal to the original ratings, because of fouling or other deterioration. Performance ratings also need to be adjusted to account for the new anticipated operating conditions. Capacity of the existing chillers should be verified by test before completing the sizing of the storage system.

ARI *Guideline T* defines the minimum information to be provided by prospective users when specifying performance requirements for cool storage equipment, and the minimum information to be provided by suppliers about their equipment's thermal performance. The hourly operating profile as described previously includes user-specified data requirements from *Guideline T*, as well as additional information useful for design.

The project specification should require that submittals for cool storage equipment provide all supplier-specified information required by *Guideline T*. The project specification should also require that the equipment be guaranteed to perform as represented by the submittal data when tested according to a specified procedure. Test methods are discussed in ASHRAE *Standards* 94.2 and 94.3.

The capacity of chilling equipment is an important aspect of sizing a cool storage system. ARI *Standard 550* allows actual capacities to deviate by approximately $\pm 5\%$ from the manufacturer's ratings. A 5% shortfall in chiller capacity, accumulated over one or more storage cycles, can result in a significant shortage of cooling capacity, which may make it impossible to meet the design cooling loads.

Designers may wish to include a requirement for zero negative capacity tolerance in chiller specifications. Such a requirement should also include provisions for factory testing and certification of the actual chiller's capacity. This may be a consultant- and/or customer-witnessed test. Some designers may elect to include a safety factor of 5 to 10% in the chiller capacity specification. This can be accomplished, for example, by specifying a chiller capable of cooling 105% of the design flow rate at the design temperatures (Dorgan and Elleson 1993).

Judicious use of safety factors is good engineering practice. However, the economics of cool storage are particularly sensitive to misapplication of safety factors. Safety factors should not be used as a substitute for sound engineering principles. The most successful systems are designed with modest safety factors for chiller and storage capacity.

Successful systems are also designed with flexibility to change operating strategies if operating requirements change or if loads increase. In cases with a high probability of increased future loads, designs should include provisions for adding capacity. Operating strategies should, as a minimum, be designed to ensure that excess capacity is used to full advantage, if actual loads are lower than projected. This further reduces operating costs.

APPLICATION OF THERMAL STORAGE SYSTEMS

Chilled-Water Storage Systems

Sensible storage may be applied to any cooling load within its application temperature range. Stratified chilled-water storage systems have been successfully applied in hospitals, schools, industrial facilities, campus and district cooling systems, power generation (combustion turbine inlet air cooling), emergency cooling systems, and others. Sensible storage tends to be the most competitive in large applications (above 3000 ton-hours or millions of gallons of storage medium) because of the low cost per ton-hour of large storage volumes. However, smaller systems are installed occasionally for a variety of reasons. For example, emergency cooling systems that may be required to discharge for only 10 or 20 min may be quite

small relative to typical load-shifting systems. Various thermal storage project delivery methods are possible. Numerous manufacturers produce turnkey storage tanks, and they may team with engineering and construction firms in a design/build relationship. At the other extreme, many systems have been designed successfully by mechanical engineering firms using generic water storage tanks, possibly with the assistance of a specialty consultant to design diffusers and advise on interface design and, possibly, the controls. It is particularly important that the storage design be such that the storage system will be properly integrated with the existing system, so the storage system designer must be expert in chilled-water system design generally.

Sensible storage vessels can be connected to chilled-water systems in a variety of ways. One common approach is to associate the storage system with the chilled-water plant so it functions as an alternative source of capacity but has no effect on distribution of flow to end users. Sensible storage can also be located remotely from the chilled-water plant, in which case it functions like a satellite plant. This approach has been used in systems that were experiencing distribution system capacity limitations (Andrepoint and Kohlenberg 2005; Borer and Schwartz 2005). Storage can be charged when loads are low, and used to backfeed the distribution system during peak periods. Examples of several Australian systems with satellite storage are described by Bahnfleth et al. (2003b).

A typical inside-the-plant connection scheme for a stratified sensible storage system serving a primary/secondary chilled-water system is shown in [Figure 18](#). As indicated by flow arrows, the direction of flow between the storage tank and the system must reverse between the charge and discharge modes. The storage vessel is connected to the system by a transfer pumping interface, which controls the direction of flow between the tank and the system and accommodates pressure differences between the system and the tank. This is necessary in stratified tanks (typically open to the atmosphere) only when the tank water level is below the highest point in the chilled-water system. Under such conditions, an interface is needed to exchange thermal energy with the system while preventing the elevated system water from draining into the tank and overflowing.

The transfer pumping interface in [Figure 18](#) may have several configurations, the two most common of which are shown in [Figures 19](#) to [22](#). These figures are schematic. They do not show pump trim items such as check valves and strainers. One pump is shown, but multiple pumps in parallel are used in many systems. Likewise, parallel control valves may be specified in some systems to provide the required rangeability.

[Figure 19](#) shows a direct interface, which allows water to flow between the tank and the system while maintaining tank and system pressure levels by using modulating pressure-sustaining valves. The example shown has four two-position valves and two pressure-sustaining valves. It is configured so the pump always pumps out of

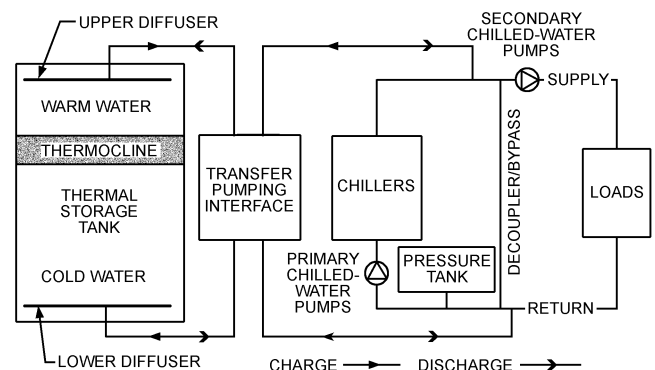

Fig. 18 Typical Sensible Storage Connection Scheme

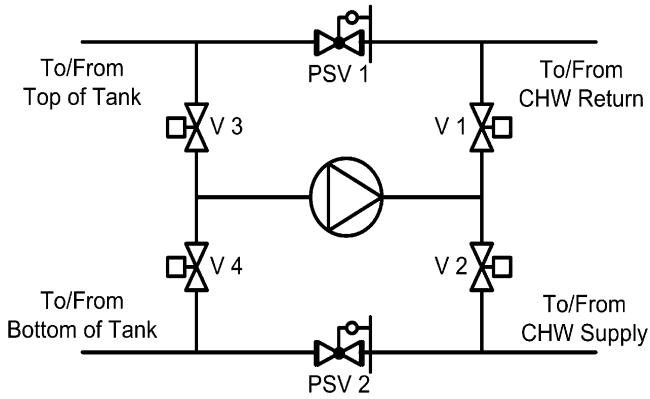

Fig. 19 Direct Transfer Pumping Interface

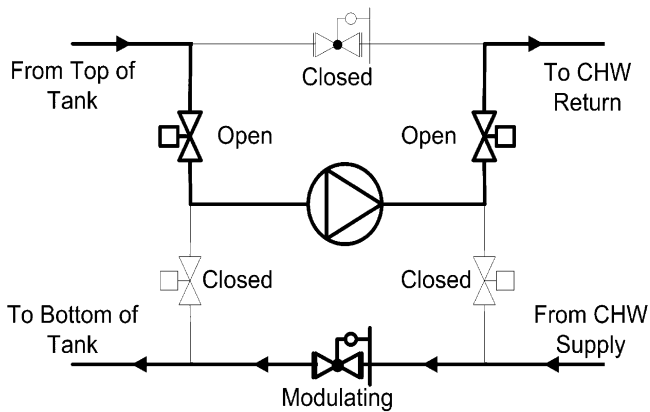

Fig. 20 Charge Mode Status of Direct Transfer Pumping Interface

the tank into the system (i.e., from the lower-pressure zone to the higher-pressure zone). Figure 20 illustrates valve status and flow paths for charge mode. One pair of two-position valves is open and the other pair is closed, and one pressure-sustaining valve modulates and the other is closed. The status of all valves is reversed during discharge mode.

If the water level in the storage tank is at or above the water level in the tallest building or highest air handler or piping run, pressure-sustaining valves are unnecessary. In this case, the only valves required would be to change flow direction when the system is switched from the charge mode to the discharge mode and vice versa. In some cases (see Figure 23), no valves are needed to change the direction of flow.

Figure 21 is an example of an indirect interface that connects the thermal storage system and the chilled-water system through a heat exchanger, which is typically a plate-and-frame heat exchanger with a 2 to 3°F maximum approach temperature. Figure 22 illustrates valve status and flow paths for charge mode. The advantage of this approach over the direct interface is that it eliminates the pressure control problem, and may save pumping energy if there is a large static pressure difference between the tank and the system. However, the added installation and energy cost of this scheme is significant, because of the number of additional components and unavoidable loss of storage capacity caused by the temperature differences (4 to 6°F) across the heat exchanger during charging and discharging. This loss of differential temperature causes a major penalty in pumping energy consumption.

For example, suppose that the chilled-water system in Figure 18 has a supply (and charging) temperature of 40°F and a return temperature of 60°F. If the heat exchanger in an indirect interface

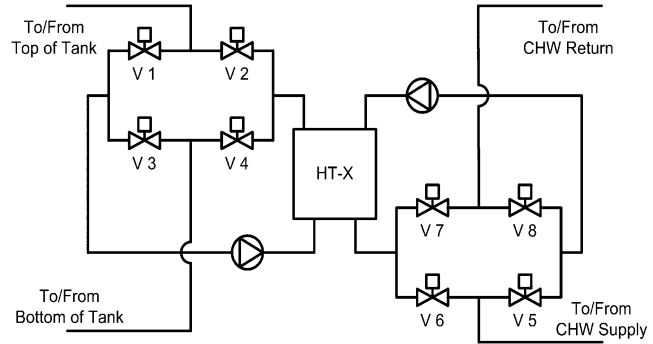

Fig. 21 Indirect Transfer Pumping Interface

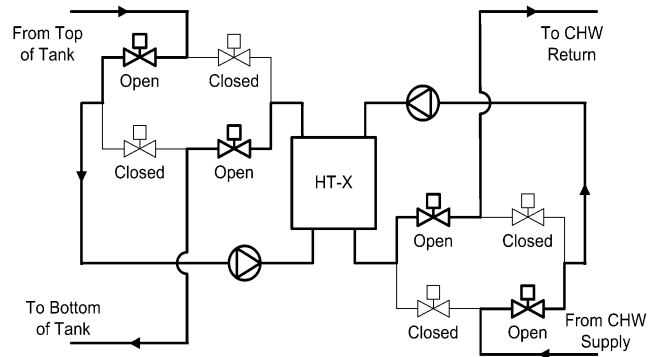

Fig. 22 Charge Mode Status of Indirect Transfer Pumping Interface

has a 2°F approach, the temperature of water in the charged tank will be 42°F and after complete discharge it will be 58°F. Consequently, the maximum temperature difference to which the storage medium is subjected is 16°F, rather than the 20°F that could be achieved with a direct interface. To have the same capacity as a direct interface system, the tank of the indirect interface system needs to be 25% larger.

Bahnfleth and Kirchner (1999) performed a parametric study of transfer pumping interface economics for direct and indirect interfaces as well as direct interfaces with hydraulic energy recovery. Considering the increased cost of the storage tank to achieve equal storage capacity when an indirect interface is used, this study concluded that, until static pressure differential reaches several hundred feet of water, the life-cycle cost of a direct interface is much more acceptable than for an indirect interface system.

An alternative to the centralized indirect interface shown in Figures 18 and 21 is to isolate loads that are at higher elevation than the tank water level. This may result in lower system cost than a central heat exchanger, and significantly lower pumping energy consumption than a direct interface system. An analysis must be made to determine the total cost and energy consumption of the distributed pump/pressure-sustaining valve approach relative to centrally located valves at the storage tank to ensure that the proper scheme is being specified.

When it is possible to design the thermal storage tank surface to be the high water level in the system, it can function as the expansion tank and possibly provide a much simpler system design. One particularly attractive arrangement is to use the thermal storage tank as the decoupler in a primary/secondary system, as shown in Figure 23. In this system, if the flow demanded by the secondary pump exceeds the flow provided by the primary pump serving the chiller, the difference is withdrawn from the bottom of the tank and replaced by return water at the top. During charging, any surplus flow available from the chiller after the system load is met enters the

bottom of the tank, displacing warm water, which flows from the top of the tank to the chiller.

Figure 23 also represents a possible configuration for a stratified emergency cooling system of the type used in some data centers and other critical loads to cover transitions to emergency systems during an equipment failure. These systems may discharge at a very high rate for a period of only a few minutes. A piping and control configuration that allows stored capacity to be available instantly, without any valve repositioning, is required.

Ice (and PCM) Storage Systems

Partial storage applications present the greatest challenge in allocating the relative contributions of chiller and storage to the cooling load. The goal is to minimize energy cost while preventing premature exhaustion of the storage capacity. Storage devices have a finite total capacity in ton-hours and an instantaneous capacity (tons) that may vary with storage inventory and coolant temperature. Ice storage systems that use secondary coolants incorporate most of the essential design elements, and the following discussion assumes this type of storage system. Note that, even on the design day, there are hours that are less than peak load. A conventional-system chiller would unload during these hours, but partial storage sizing often takes advantage of the fact that the chiller can be fully loaded throughout the design day, minimizing the investment in equipment and maximizing the efficiency of chiller operation.

On the design day, the operating logic is usually predetermined and obvious. The challenge in maximizing energy and demand savings usually occurs on days with reduced load, which, of course, comprises most of the operating hours. Control schemes can be as simple or as complex as desired, consistent with the utility rate; building load patterns; and the training, experience, and commitment of the system operators. Very effective control schemes have been as straightforward as hot day/mild day/cool day. The chiller is fully loaded on a hot day, half-loaded on a mild day, and off on a cool day. An increased level of complexity might attempt to limit demand for each billing period. There is a minimum chiller demand that can be predicted for any billing period, either by analysis of cooling loads, from experience, or established by a demand ratchet from a previous month.

Because there is no avoidable demand penalty (kilowatts) for chiller operation up to this level, the cost of energy (kilowatt-hours) becomes the dominant influence when lower-load days are addressed. If there is a significant difference in on-peak and off-peak rates, further reduction in the hours of on-peak chiller operation is

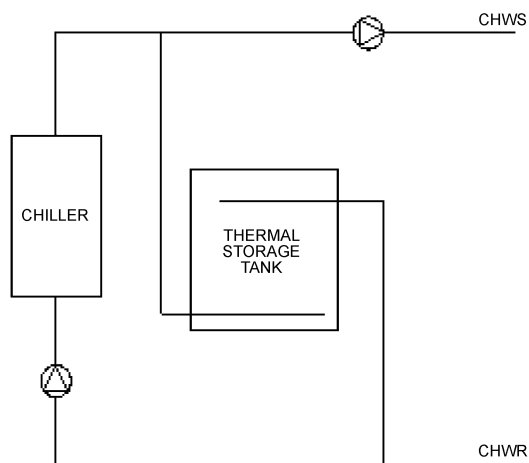

Fig. 23 Primary/Secondary Chilled-Water Plant with Stratified Storage Tank as Decoupler

warranted, if practical. If the rates are approximately equal, chiller operation up to this preestablished limit carries no penalty. In either case, demand savings are maximized. Even more complex methods are available that track storage inventory, cooling load, outdoor conditions, etc., and then modulate chiller loading to maximize savings under specific utility rates. In most cases, simple control schemes are very effective and more long-lasting with the operators.

The three-way storage valve (V1 in Figures 24 to 26) responds to two separate system characteristics: (1) the variation in the required contribution from storage as the building load ramps up and down and as the chiller capacity varies, and (2) the storage system's variable performance.

The temperature of coolant exiting the storage device is a function of flow, inlet temperature, and ice inventory. The temperature-modulating valve automatically compensates for all of these effects, in addition to providing isolation of storage when necessary.

Ice Making. Each system depicted in Figures 24 to 26 includes a temperature-blending valve (V1) around the storage module. This valve is simply driven to direct all flow through the storage device during the ice-making period. Termination of ice making may be indicated by an inventory measurement or by the attainment of a specific coolant temperature. The chiller is typically fully loaded for the duration of ice making. Once a full charge is reached, further ice-making operation is prevented until the next scheduled ice-making period.

It is often necessary to serve a cooling load during the charging mode. The ability to efficiently meet small night loads is a major advantage of storage systems. The temperature of coolant circulating in the primary loop during charge mode is below 32°F and considerably lower than that normally delivered to the secondary load loop. Although a separate chiller operating at a higher temperature can be used to meet night loads, an additional three-way valve (V2) and bypass (illustrated in Figures 24 to 26) is often placed in the secondary loop so warm return fluid can temper the coolant delivered to the load from the ice-making primary loop. This is critical when pure water load loops are served through a heat exchanger. If a night load is present after charging is completed, valve V1 can be positioned to bypass storage, and the chiller can be operated at standard daytime temperatures. If no night loads (i.e., during ice-making) are anticipated, this valve and bypass can be eliminated, because all daytime temperature control can be accomplished with the chiller or storage three-way valve.

Series Configuration. A common piping scheme is to place the chiller and storage in series. This arrangement provides several advantages. It does not require a change in flow path during charging when both storage and chiller must be in series. A parallel arrangement usually necessitates a change in flow path as the system cycles between charge and discharge. Simple control mechanisms can be used to vary the contribution of each component to the cooling load. All modes of operation (chiller only, ice only, or any ratio of chiller and ice) are easily implemented. Also, the manufacturer may recommend that flow through the storage equipment be in the same direction for charge and discharge. The series arrangement automatically accomplishes this.

Partial storage systems use on-peak chiller capacities that typically vary from 40 to 70% of the peak load. Because it would be difficult to direct full system flow through the smaller chiller and storage at the common 10 or 12°F temperature range, series systems often use a wider differential Δt in supply and return temperatures. Ranges of 14 to 16°F are fairly common, with up to 20°F occasionally used. Flow rates are consequently lowered to levels compatible with the equipment, and pumping energy can be reduced throughout the system. For the series flow examples, 42°F supply and 58°F return at peak load are assumed.

Series Flow, Chiller Upstream. In the upstream position (Figure 24), the chiller often operates at higher daytime evaporator

temperatures than it would have in the conventional system, although there may be a negative effect on total storage capacity.

If the maximum on-peak chiller capacity is half of the on-peak load, the chiller reduces the return temperature by half the design Δt , to 50°F at peak load. However, if the chiller leaving chilled-water temperature (LCWT) is simply set to 50°F, the chiller will unload any time the load is less than peak, as the return temperature decreases. This may shift cooling load to storage that should have been served by the chiller, resulting in premature depletion of storage capacity and the inability to meet the cooling load later in the day. Alternatively, by setting the chiller LCWT at 42°F, the chiller meets all cooling loads up to its full capacity, before any load is imposed on storage. In some cases, this can be the extent of the discharge control logic. In fact, through simple adjustment of the chiller supply water temperature set point or chiller demand limits, cooling load can be shifted between chiller and storage in any desired proportion to best exploit the electric rate in response to daily or seasonal load changes. As the load fluctuates and the related chiller contribution varies, the storage three-way modulating valve automatically directs sufficient flow through the storage system to maintain 42°F coolant delivered to the load.

Series Flow, Chiller Downstream. Reversing the arrangement retains all of the control flexibility, because the storage modulating valve can be used to manage the relative contributions of storage and chiller (Figure 25). Storage capacity is maximized at the expense of some chiller efficiency, which in many cases is minimal. At peak load, the storage blending valve is set to 50°F, and the chiller will be fully loaded as it further reduces the temperature to 42°F. Maintaining this storage temperature set point keeps the chiller fully loaded throughout the day, minimizing use of storage capacity. On cooler days, the storage blended outlet temperature can be reduced. Chiller capacity and electric demand are also reduced. Alternatively, chiller demand limiting can be used and the storage blending valve temperature sensor can be located downstream of the chiller. The storage automatically meets any load in excess of the chiller limit to maintain the desired supply water temperature.

In either the chiller upstream or downstream arrangement, simple temperature control or chiller demand limiting can easily manipulate the cooling loads imposed on either storage or the chiller system.

Parallel Flow. There are times when a parallel flow configuration is preferred, perhaps to address a retrofit application with a fixed-distribution Δt . Chillers in parallel load and unload in response to cooling needs. In storage applications, it is essential that storage is not simultaneously unloaded as the chiller is unloaded.

There are many variations on the parallel flow theme. Referring to the simplified schematic of Figure 26, a two position, three-way valve (V3) at the chiller outlet is included to redirect flow for the charge and discharge modes. This example assumes that the chiller meets 60% of the daytime peak load.

During discharge, in parallel, the same return-temperature fluid enters both the chiller and storage. With no control other than a fixed leaving temperature for both storage and chiller, the contributions of storage and chiller vary in a constant ratio as the return temperature varies. Because even on a design day, the return temperature may be reduced during much of the day, it is apparent that the chiller will unload. If the original selection assumed full capacity from the chiller during all hours, the system would then be undersized.

To avoid this problem, chiller temperature can be allowed to drop to maintain full load, and the storage blending valve sensor can be repositioned to sense the chiller/storage combined flow temperature. Variable-speed pumping of the storage loop is also possible, to maintain a fully loaded chiller at a constant chiller leaving temperature. Storage systems typically have a broad range of acceptable flow rates.

Further complications arise when chillers are demand-limited to optimize utility cost. In a constant-flow chiller loop, the chiller leaving temperature generally rises when the chiller is unloaded, necessitating a drop in storage temperature to compensate. The storage system may not have been selected to operate at the lower temperature. Variable chiller flow can provide a full system Δt at reduced capacity. In any case, it becomes more awkward to optimize load sharing between the chiller and the storage. The best approach is, regardless of system configuration, to calculate flows and temperatures resulting from the proposed control logic at a variety of cooling loads, and ensure that results are consistent with the assumptions made during equipment selection.

A versatile storage design allows the system to shift load between chiller and storage to best exploit the utility rate, thereby optimizing the total utility bill. Accompanying this versatility is the responsibility to ensure that loads are properly shared by chiller and storage under all conditions.

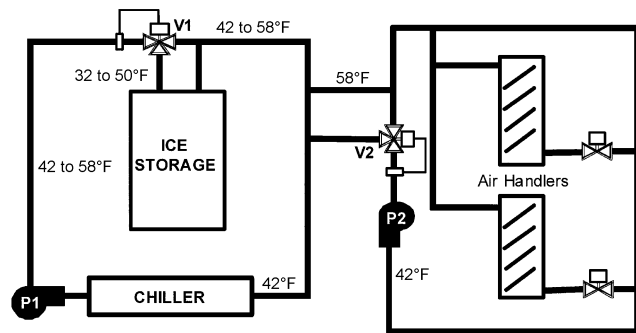

Fig. 25 Series Flow, Chiller Downstream

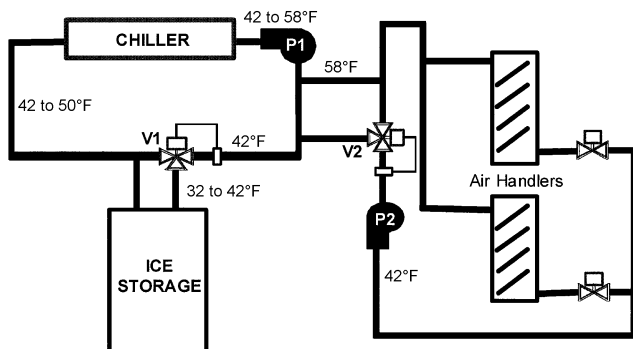

Fig. 24 Series Flow, Chiller Upstream

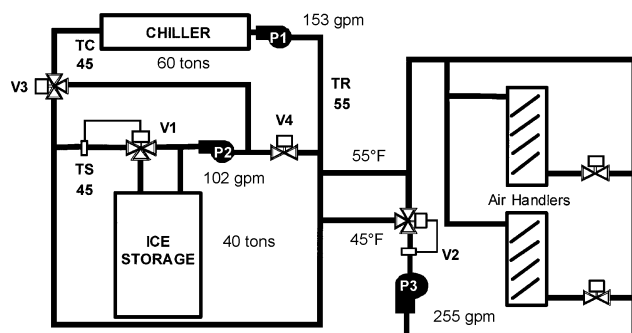

Fig. 26 Parallel Flow for Chiller and Storage

OPERATION AND CONTROL

Thermal storage operation and control is generally more schedule-dependent than that of instantaneous systems. Because thermal storage systems separate the generation of heating and cooling from its use, control of each of these functions must be considered individually. Many thermal storage systems also offer the ability to provide heating or cooling either directly or from storage. This flexibility makes it necessary to define how loads will be met at any time under various scenarios.

ASHRAE Research Project RP-1054 (Dorgan et al. 1999, 2001) developed a framework for describing and characterizing the many methods for controlling thermal storage systems. The methods were defined in terms of the following levels of control:

- Available **operating modes**. A thermal storage operating mode describes which of several possible functions the system is performing at a given time (e.g., charging storage, meeting load directly without storage, meeting load from discharging storage, etc.).
- **Control strategies** used to implement the operating modes. A thermal storage control strategy is the sequence of operating modes implemented under specific conditions of load, weather, season, etc. For example, different control strategies might be implemented on a design day in the summer, a cool day in the summer, and a winter day.
- The **operating strategy** that defines the overall method of control for the thermal storage system to achieve the design intent. The operating strategy provides the logic used to determine when the various operating modes and control strategies are selected. A system designed to minimize on-peak demand uses a different operating strategy than one designed to minimize use of on-peak energy or installed equipment capacity.

The design of a thermal storage system should include a detailed description of the intended operating strategy and its associated control strategies and operating modes. Dorgan et al. (1999, 2001) provides specific recommendations for documenting each of these elements of operation and control. The researchers also recommend that graphical illustrations be used to describe each operating mode and the logic used to select each mode. The documentation should address control for the complete storage cycle under full- and part-load operation, including variations related to seasonal conditions.

The operating mode, control strategy, and operating strategy framework is useful for describing the operation and control of sophisticated thermal storage systems, and for comparing the operation and control of multiple systems. Many systems use a limited number of operating modes and control strategies. For example, a simple storage system may have a single control strategy with just two modes of operation: charging and discharging (meeting load). Although the complete framework is not necessary to describe the control of such a system, it is still important for the designer to recognize and document how a system is intended to be controlled under all conditions.

Design documentation should also include the basic parameters that helped determine the operating strategy, sizing strategy (full or partial storage), the energy cost structure and the general design intent.

Operating Modes

The five most common thermal storage operating modes are described in [Table 2](#). The operating modes used in each individual thermal storage system design vary. Some systems may use fewer modes; for example, the option to meet a building load while charging may not be available for a specific system design, when there is no cooling load during the time the system is being charged. Many systems operate under only two modes of operation: daytime and nighttime.

Table 2 Common Thermal Storage Operating Modes

Operating Mode	Heat Storage	Cool Storage
Charging storage	Operating heating equipment to add heat to storage	Operating cooling equipment to remove heat from storage
Charging storage while meeting loads	Operating heating equipment to add heat to storage <i>and</i> meet loads	Operating cooling equipment to remove heat from storage <i>and</i> meet loads
Meeting loads from storage only	Discharging (removing heat from) storage to meet loads without operating heating equipment	Discharging (adding heat to) storage to meet loads without operating cooling equipment
Meeting loads from storage and direct equipment operation	Discharging (removing heat from) storage <i>and</i> operating heating equipment to meet loads	Discharging (adding heat to) storage <i>and</i> operating cooling equipment to meet loads
Meeting loads from direct equipment operation only	Operating heating equipment to meet loads (no fluid flow to or from storage)	Operating cooling equipment to meet loads (no fluid flow to or from storage)

Many systems also include additional operating modes, such as

- Charging cool storage from free cooling (hydronic economizer)
- Charging cool storage while recovering condenser heat
- Charging heat storage with recovered condenser heat
- Discharging at distinct supply temperatures
- Discharging in conjunction with various combinations of equipment

In general, the control system selects the current operating mode based on the time of day and day of the week. Other factors that may be considered in this selection include outdoor air temperature, current system load, total facility utility demand at the billing meter, and amount of storage available compared to the storage system capacity. The logic for mode selection is defined as part of the operating strategy.

In some cases, particularly for large cool storage systems with multiple chillers and multiple loads, different operating modes or control strategies may be applied to different parts of the system at one time. For example, one chiller may operate in charging-only mode, while another chiller may operate only to meet a building load.

An operating mode is defined by its control sequence, or sequence of operation. The specified control sequence defines the specifics of what equipment is to be operated, the values of the control system set points, the function of each control valve and other control device, and any other function necessary to achieve the design intent for that operating mode. These all result in a description of individual control loops and their responses to changes in loads or other variables.

Charging Storage with No Load. Control sequences for the storage charging-only mode are generally easily defined. Typically, the generation equipment (e.g., chillers or boilers) operates at full capacity with a constant supply temperature set point and constant flow through the storage system. Charging begins at a specified time and continues until the storage is considered fully charged or the period available for charging has ended. Under this scenario, all equipment designated as being available for charging is operated for storage purposes.

Charging Storage While Meeting the Load. This mode is more complex than the charging-only mode, but is necessary in systems that must meet loads during the charging period, such as in hospitals, data centers, etc. Control sequences for this mode generally operate all designated generation equipment at its maximum capacity. Capacity that is not needed to meet the load is diverted to

charging storage. Depending on the system design, the load may be piped in series or in parallel with the storage tank. Some systems may have unique requirements in this mode to allow both charging storage and distribution of capacity to meet the load. For example, for an ice storage system using a heat exchanger between a glycol/water mixture and chilled-water loop, the designer may need to address freeze protection on the chilled-water loop side of the heat exchanger.

Meeting Load from Discharging Only. A control sequence for the discharging-only mode (full storage or load shifting) is generally straightforward. The generating equipment is not operated and the entire load is met from the storage system.

Meeting Load from Discharging and Direct Equipment Operation. Control sequences for this mode, used in partial storage operation, must regulate the portion of the load at any time that will be met from storage and the proportion that will be met from direct generation. These control sequences are typically more complex, because more variables come into play in selecting what equipment to operate and at which capacity. These sequences have generally been applied to cool storage systems, although they could be equally applied to heat storage systems. The discussion here is based on cool storage applications. There are three common control sequences used for this mode: chiller-priority, storage-priority, and constant-proportion control.

Chiller-priority control includes operating the chilling equipment, up to the designated available capacity, to meet loads. Cooling loads in excess of this capacity are then met by the storage system. If a demand limit is in place, either on the facility, cooling plant, or individual chilling equipment, the available chilling equipment capacity can be less than the maximum system capacity.

Chiller-priority control can be implemented with any storage configuration; however, it is most commonly applied with the refrigeration equipment in series with and upstream of the storage components. A simple implementation method is to set both the chiller and storage discharge temperature set points equal to the desired system supply water temperature. When the load is less than that available from the cooling equipment, the equipment operates as required to maintain the set point. When the system load exceeds the available cooling equipment capacity, the supply temperature increases above its set point, which requires some flow to be diverted through the storage system to satisfy the load. It is important to note that sensing errors in downstream temperature measurement may cause the unintentional use of storage before the available equipment capacity has been fully used. When premature depletion happens, the usable storage capacity is not available when it was intended and originally scheduled, thereby resulting in a demand penalty, which will show up on the utility bill.

Storage-priority control meets the load from storage up to its available maximum discharge rate. When the load exceeds this discharge rate, the cooling equipment must operate to meet the remaining load. A storage-priority control sequence must ensure that the storage system is not depleted prematurely during the discharge cycle. Failure to properly control or limit the maximum discharge rate could result in loss of control of the cooling load, unexpected demand charges, or both. Load forecasting is required to optimize the benefits of this control method. [Chapter 41](#) describes a method for forecasting diurnal energy requirements. Simpler storage-priority control sequences have also been used that include using constant system discharge rates, predetermined system discharge rate schedules, or other load predictive and control methodologies.

Constant-proportion control or **proportional control** sequences divide the load between cooling equipment and storage. The load may be divided equally or in some other specific proportion that can then be changed in response to changing conditions. Limits on the storage system discharge rate or a demand-limiting requirement on the cooling equipment, plant or facility wide, may be applied in determining these proportions.

Demand-limiting control may be applied to any of the aforementioned sequences. This control method attempts to limit the facility or cooling plant demand by either setting a maximum capacity above which the cooling equipment cannot operate or by adjusting the cooling equipment discharge temperature set point. Because chiller demand can be a significant portion of overall system demand, large demand savings are possible with this control sequence. The demand limit may be a fixed value or may change in response to predefined changes in specific conditions. Demand limiting is generally most effective when chiller capacity is controlled in response to the total demand for a facility at its billing meter. A simpler approach, which generally results in reduced demand savings, is to limit chiller capacity based on its electric demand without consideration of the facility's demand.

The storage system discharge rate may also be limited, similar to the approach taken with chiller demand limiting. Such a limit is typically used with storage priority control to ensure that sufficient capacity is available for the entire discharge cycle. The discharge rate limit may change with time based on changing conditions. The discharge rate limit can be defined as the maximum instantaneous cooling capacity supplied from the storage system. Alternatively, it may be expressed as the maximum discharge flow rate through the storage system or the minimum mixed-fluid temperature in the common discharge of the storage system and the associated bypass.

Operating strategies that continually seek to optimize system operation frequently recalculate the demand and discharge limits during the discharge period.

Nearly all partial-storage system sequences can be described by indicating (1) whether chiller-priority, storage-priority, or proportional control is to be used; and (2) by specifying the applicable cooling equipment demand limit and storage system discharge rate limit.

Applicable utility rates and system efficiency in the various operating modes ultimately determine the selection of the preferred control sequences. If on-peak energy cost is significantly higher than off-peak energy cost, use of stored energy should be maximized during on-peak period(s), and a storage-priority sequence is appropriate. If on-peak energy cost is not significantly more than off-peak energy cost, a chiller-priority sequence is appropriate. When demand charges are high, some type of demand-limiting control scheme should be implemented.

Control Strategies

A thermal storage **control strategy** is the sequence of operating modes implemented under specific conditions of load, weather, season, etc. For example, a control strategy for a summer design day might specify a discharging mode, using storage-priority control during daytime on-peak hours to minimize or eliminate on-peak chiller operation. A winter day control strategy for the same system might use a chiller-priority discharge mode to minimize the storage system operation, because the utility rates are normally close to the same value day and night, thereby negating much of the benefit of thermal storage.

Operating Strategies

It is important to distinguish between the operating strategy, which defines the higher-level logic by which the system operates, and the various control strategies, which implement the specific operating modes. The operating strategy outlines the overall method of control of the thermal storage system necessary to meet the design intent. The operating strategy determines the logic that dictates when each operating mode is to be energized, as well as the control strategy that is implemented in each mode.

Dorgan and Elleson (1993) used the term "operating strategy" to refer to full-storage and partial-storage operation. That discussion focused on design-day operation and did not discuss operation

Table 3 Recommended Accuracies of Instrumentation for Measurement of Cool Storage Capacity

	Temperature, °F	Temperature Differential, °F	Flow Rate, % of reading
Accuracy	±0.3	±0.2	±5%
Precision	±0.2	±0.15	±2%
Resolution	±0.1	±0.1	±0.1%

Notes: Accuracy is an instrument's ability to repeatedly indicate the true value of the measured quantity. Precision is closeness of agreement among repeated measurements of the same variable. Resolution is the smallest repeatable increment in the value of a measured variable that can be accurately measured and reported by an instrument. Values stated are maximum acceptable deviations of sensed and transmitted value from actual value, as measured by a sensor meeting industry standard for testing instrumentation and that is certified periodically to ensure its own accuracy. See Chapter 14 of the 2005 ASHRAE Handbook—Fundamentals for more information on instrumentation and measurement principles.

under all conditions. For example, a system designed for partial-storage operation on the design day may operate under a full-storage strategy during other times of the year.

Operating strategies that use sophisticated control routines to optimize the use of storage have been investigated (Drees 1994; Henze et al. 2005). The cost savings benefits of such optimal strategies are often small in comparison to well-designed basic strategies that rely on simpler control routines.

Instrumentation Requirements

The control system for a thermal storage system must include at least measurement points for the following fluid temperatures:

- Entering and leaving chiller(s)
- Entering and leaving storage
- To and from load

In addition, the system should include the ability to measure flow rates at the chiller(s), storage, and load, as well as electric power to the chiller(s) and auxiliaries. Some method of measuring the current storage inventory is also necessary.

Systems with control strategies that rely on measurement of load and capacity may require flow and temperature sensors of higher quality than those normally provided with HVAC control systems. The more accurate instruments are readily available, the cost above standard sensors is nominal compared to the overall cost of the total control system, and the benefits realized are extremely valuable over the life of the system. The accuracy requirements must be included in the specifications to ensure that appropriate instrumentation is provided. Field validation is recommended.

For most applications, the recommended sensor accuracies listed in Table 3 provide an uncertainty of under ±10% in cool storage capacity measurements. When accuracy requirements are critical, the design team should carry out an uncertainty analysis to determine the required accuracy of individual sensors. Note that the accuracy of the system for transmitting and reporting the measured quantities must also be considered. It is not wise to assume that all systems provide the same level of accuracy, regardless of the cost of the system or the components.

If the control system is to be used for performance monitoring, it should be selected for its ability to

- Collect and store required amount of trend log data without interfering with system control functions
- Report averages of measured quantities over a selected interval
- Calculate amount of cooling supplied to or from load, chillers, and storage
- Provide trend log reports in custom formats to fit users' needs
- Provide maximum daily cooling water temperature provided to load, and time of occurrence
- Provide maximum daily water temperature provided from storage to load, and time of occurrence

OTHER DESIGN CONSIDERATIONS

Hydronic System Design for Open Systems

For reasons of cost and ease of construction, large ice storage and chilled-water storage tanks are typically vented to the atmosphere. When, as frequently occurs, the fluid level in a storage tank is not the highest point in the system, special attention must be paid to pumping system design to ensure that the different pressure levels are maintained and the tank does not overflow. The overview of possible transfer pumping interfaces presented in this chapter identifies the main issues requiring attention in open-system design and some ways they have been successfully addressed in chilled-water storage systems installed to date. The design guide of Gatley and Mackie (1995) provides a comprehensive discussion of open systems.

Cold-Air Distribution

The low cooling supply temperatures available from ice storage and some other cool storage media allow the use of lower supply air temperatures, which permits decreased supply air volume and smaller air distribution equipment. This approach leads to the following benefits:

- **Reduced mechanical system costs**, particularly for fans and ductwork. The cost for electrical distribution to fans may also be reduced.
- **Reduction of 30 to 40% in fan electrical demand and energy consumption.**
- **Reduced space requirement for fans and ductwork.** In some cases, this can reduce the required floor-to-floor height, with significant savings in structural, envelope, and other building systems costs. In this case, if the building is being built in an area with strict height limitations, additional floor(s) may be possible, thereby greatly increasing the value of the building.
- **Improved comfort with lower space relative humidity.** Laboratory research has shown that people feel cooler and more comfortable at lower relative humidities, and air is judged to be fresher with a more acceptable air quality, as experienced with cold-air distribution systems.
- **Increased cooling capacity for existing distribution systems.** By reducing supply air temperatures, owners can avoid the expense of replacing or supplementing existing air distribution equipment.

The cost reduction enabled by cold-air distribution can make thermal storage systems competitive with nonstorage systems on an initial-cost basis (Landry and Noble 1991; Nelson 2000).

Lower supply temperatures provide greater benefits from reduced size and energy use; however, this technology involves greater departure from standard engineering practice and requires increased attention to condensation control and other critical considerations. Nominal supply air temperatures as low as 42°F can be achieved with 36°F fluid, which can be supplied from ice storage; however, 45°F supply air is a more efficient target. Supply air temperatures of 48 to 50°F can be achieved with minimal departure from standard practice and still provide significant cost reductions. The optimum supply air temperature should be determined through an analysis of initial and operating costs for the various design options.

The minimum achievable supply air temperature is determined by the chilled-fluid temperature and temperature rise between the cooling plant and terminal units. With ice storage systems, in which the cooling fluid temperature rises during discharge, the design fluid supply temperature should be based on the flow-temperature profiles of the secondary fluid and the characteristics of the selected storage device.

A heat exchanger, which is sometimes required with storage devices that operate at atmospheric pressure or between a secondary coolant and chilled-water system, adds at least 2°F to the final

chilled-fluid supply temperature above the generated temperature. The temperature difference between supply fluid entering the cooling coil and air leaving the coil is generally 6 to 10°F. A closer approach (smaller temperature differential) can be achieved with more rows or a larger face area on the cooling coil, but extra heat transfer surface to provide a closer approach is often uneconomical. A 3°F temperature rise in the air between the coil discharge and supply to the space can be assumed for preliminary design analysis. This is from heat gain in the duct between the cooling coil and terminal units. With careful design and adequate insulation, this rise can be reduced to as little as 1°F.

For a given supply air volume, the desired face velocity determines the size of the coil. Coil size determines the size of the air-handling unit. A lower face velocity achieves a lower supply air temperature, whereas a higher face velocity results in smaller equipment and lower first costs. Face velocity is limited by the possibility of moisture carryover from the coil. For cold-air distribution, the face velocity should be 350 to 450 fpm, with an upper limit of 550 fpm.

Cold primary air can be tempered with room air or plenum return air using fan-powered mixing boxes or induction boxes. The energy use of fan-powered mixing boxes is significant and negates much of the savings from downsizing central supply fans (Elleson 1993; Hittle and Smith 1994). Diffusers designed with a high ratio of induced room air to supply air can provide supply air directly to the space without drafts, thereby eliminating the need for fan-powered boxes.

If the supply airflow rate to occupied spaces is expected to be below 0.4 cfm/ft², fan-powered or induction boxes should be used to boost the air circulation rate. At supply airflow rates of 0.4 to 0.6 cfm/ft², a diffuser with a high ratio of induced room air to supply air should be used to ensure adequate dispersion of ventilation air throughout the space. A diffuser that relies on turbulent mixing rather than induction to temper the primary air may not be effective at this flow rate.

Cold-air distribution systems normally maintain space relative humidity between 30 and 45%, as opposed to the 50 to 60% rh generally maintained by other systems. At this lower relative humidity level, equivalent comfort conditions are provided at a higher dry-bulb temperature. The increased dry-bulb set point generally results in decreased energy consumption.

In most buildings using cold-air distribution, relative humidity is reduced throughout the building. At these low dew-point conditions, the potential for condensation is no greater than in a higher-humidity space with higher supply air temperatures. However, spaces that may be subject to infiltration of humid outside air (e.g., entryways) may need tempered supply air to avoid condensation.

Surfaces of any equipment that may be cooled below the ambient dew point, including air-handling units, ducts, and terminal boxes, should be adequately insulated. All vapor barrier penetrations should be sealed to prevent migration of moisture into the insulation. Prefabricated, insulated round ducts should be insulated externally at joints where internal insulation is not continuous. Access doors should also be well insulated.

Duct leakage is undesirable because it represents cooling capacity that is not being delivered to the conditioned space. In cold-air distribution systems, leaking air can cool nearby surfaces to the point that condensation forms, which can lead to many other problems. Designers should specify acceptable methods of sealing ducts and air-handling units, and establish allowable leakage rates and test procedures. During construction, appropriate supervision and inspection personnel should ensure that these specifications are being followed.

The same indoor air quality considerations must be applied to a cold-air distribution design as for a higher-temperature design. The required volume of outdoor ventilation air is normally the same, although the percentage is higher for cold-air distribution systems, because the total air volume is lower. As with any design, systems

servicing multiple spaces with different occupant densities may require special attention to ensure adequate outside air is delivered to each space.

Designs using reheat should incorporate strategies to reset the supply air temperature at low cooling loads, to avoid increased energy use associated with reheating minimum supply air quantities.

Storage of Heat in Cool Storage Units

Some cool storage installations may be used to provide storage for heating duty and/or heat reclaim. Many commercial buildings have areas that require cooling even during the winter, and the refrigeration plant must, therefore, be in operation year-round. When cool storage is charged during the off-peak period, the rejected heat may be directed to the heating system or to storage rather than to a cooling tower. Depending on the building loads, the chilled water or ice could be considered a by-product of heating. One potential use of the heat is to provide morning warm-up on the following day.

Heating, in conjunction with a cool storage system, can be achieved using heat pumps or heat reclaim equipment, such as double-bundle condensers, two condensers in series on the refrigeration side, or a heat exchanger in the condenser water circuit. Cooling is withdrawn from storage as needed; when heat is required, the cool storage is recharged and used as the heat source for the heat pump. If needed, additional heat must be obtained from another source because this type of system can supply usable heating energy only when the heat pump or heat recovery equipment is running. Possible secondary heat sources include a heat storage system, solar collectors, or waste heat recovery from exhaust air. When more cooling than heating is required, excess energy can be rejected through a cooling tower.

Individual storage units may be alternated between heat storage and cool storage service. Stored heat can be used to meet the building's heating requirements, which may include morning warm-up and/or evening heating, and stored cooling can provide midday cooling. If both the chiller and the storage are large enough, all compressor and boiler operation during the on-peak period can be avoided, and the heating or cooling requirements can be satisfied from storage. This method of operation replaces the air-side economizer cycle that uses outside air to cool the building when the enthalpy of outside air is lower than that of return air.

The extra cost of equipping a chilled-water storage facility for heat storage is small. Necessary plant additions may include a partition in the storage tank to convert a portion to warm-water storage, some additional controls, and a chiller equipped for heat reclaim. The additional cost may be offset by savings in heating energy. In fact, adding heat storage may increase the economic advantage of installing cool storage.

Care should be taken to avoid thermal shock when using cast-in-place concrete tanks, one specific type of concrete tank. Tamblyn (1985) showed that the seasonal change from heat storage to cool storage caused sizable leaks to develop if the cooldown period was fewer than five days. Raising the temperature of a cast-in-place concrete tank causes no problems because it generates compressive stresses, which concrete can sustain. Cooldown, on the other hand, causes tensile stresses, under which cast-in-place concrete has low strength and, therefore, is more prone to failure. However, precast prestressed concrete tanks are not prone to this type of failure because the walls of the tank are in constant compression from the prestressing wires that are in tension and encircle the exterior of the tank walls.

System Interface

Open Systems. Chilled-water, salt and polymeric PCMs, external-melt ice-on-coil, and ice-harvesting systems are all open (vented to the atmosphere) systems. Draindown of water from the

higher-pressure system back into the storage tank(s) must be prevented by isolation valves, pressure-sustaining valves, or heat exchangers. Because of the potential for draindown, the open nature of the system, and the fact that the water being pumped may be saturated with air, the construction contractor must follow the piping details carefully to prevent pumping or piping problems.

Closed Systems. Closed systems normally circulate an aqueous secondary coolant (25 to 30% glycol solution) either directly from the storage circuit to the cooling coils or to a heat exchanger interfaced with the chilled-water system. A domestic water makeup system should not be the automatic makeup to the secondary coolant system. An automatic makeup unit that pumps a premixed solution into the system is recommended, along with an alarm signal to the building automation system to indicate makeup operation. The secondary coolant must be an industrial solution (not automotive antifreeze) with inhibitors to protect the steel and copper found in the piping. The water should be deionized; portable deionizers can be rented and the solution can be mixed on site. A calculation, backed up by metering the water as it is charged into the piping system for flushing, is needed to determine the specified concentration. Premixed coolant made with deionized water is also available, and tank truck delivery with direct pumping into the system is recommended on large systems. An accurate estimate of volume is required.

Insulation

Because the chilled-water, secondary coolant, or refrigerant temperatures are generally 10 to 20°F below those found in nonstorage systems, special care must be taken to prevent damage. Although fiberglass or other open-cell insulation is theoretically suitable when supplied with an adequate vapor barrier, experience has shown that its success is highly dependent on workmanship. Therefore, a two-layer, closed-cell material with staggered, carefully sealed joints is recommended. A thickness of 1.5 to 2 in. is normally adequate to prevent condensation in a normal room. Provisions should be made to ensure that the relative humidity in the equipment room is less than 80%, either by heating or by cooling and dehumidification.

Special attention must be paid to pump and heat exchanger insulation covers. Valve stem, gage, and thermometer penetrations and extensions should be carefully sealed and insulated to prevent condensation. PVC covering over all insulation in the mechanical room improves appearance, provides limited protection, and is easily replaced if damaged. Insulation located outdoors should be protected by an aluminum jacket.

COST CONSIDERATIONS

Cool storage system operating costs are lower in general than those of nonstorage systems. On-peak demand charges are reduced, and energy use is shifted from expensive on-peak periods to less expensive off-peak times.

Operating cost estimates can be developed to varying levels of detail and accuracy. In some cases, simple estimates based on peak demand savings may be adequate. At the other extreme, an hour-by-hour analysis, including energy consumption of chillers, pumps, and air-handler fans, may be desirable.

In many applications, most of the operating cost savings come from reductions in demand charges. Demand savings for each month of the year are calculated based on estimates or calculations of load variations throughout the year and on knowledge of system control strategies during nonpeak months. It is generally straightforward to calculate annual demand savings by repeating the design-day analysis with appropriate load profiles and rate structures for each month.

For some applications, particularly where there is a large differential between on- and off-peak energy costs, chiller energy savings

are significant. For many cool storage designs, pumping energy savings are also important. Added savings in fan energy should also be considered if cold-air distribution is used.

Annual energy savings can be estimated using energy modeling programs. However, programs currently available typically do not model the unique performance characteristics of the various storage technologies. Most programs do not consider the interaction between chiller and storage performance; the effects of chiller-upstream or chiller-downstream configuration; or the performance impacts of chiller-priority, storage-priority, and demand-limiting control strategies. In some cases, these shortcomings may offset the benefits of performing a detailed computer simulation. Additional information on calculating annual energy use is given in Dorgan and Elleson (1993) and Elleson (1997).

MAINTENANCE CONSIDERATIONS

Following the manufacturer's maintenance recommendations is essential to satisfactory long-term operation. These recommendations vary, but their objective is to maintain the refrigeration equipment, refrigeration charge, coolant circulation equipment, ice builder surface, water distribution equipment, water treatment, and controls so they continue to perform at or near the same level as they did when the system was commissioned. The control systems must be kept in calibration, water and heat transfer fluids must be treated regularly, and any valves or pumps must be maintained per manufacturer's instructions. Monitoring ongoing performance against commissioned kilowatt-hours per ton-hour of cooling capacity delivered gives a continuing report of the system's dynamic performance.

The heat transfer fluid vendor should be consulted for information on treating the heat transfer fluid. Most heat transfer fluids are supplied with required additives by the manufacturer and require annual analysis.

History of previously constructed systems indicates the importance of careful observance to the following items:

- Start-up in accordance with manufacturer's directions
- Introduction of additives in accordance with manufacturer's directions
- Regular inspections (confined-space entry program should be reviewed and in place): visual periodic electronic monitors and/or divers
- Older systems: as applicable, review for upgrade modifications to (1) diffuser system and (2) control system
- Interior and exterior materials (corrosive and noncorrosive) (piping, fasteners, supports, etc.): check for container wall under-cover insulation corrosion; repair damaged insulation
- Appurtenances (vents, ladders, overflows, temperature sensors): all well secured and sensors calibrated
- Electrical systems: well secured and connections secure

Water Treatment

Water treatment for thermal storage systems is not fundamentally different from water treatment for nonstorage systems, except that there is generally a greater volume of water to be treated. Although water close to freezing has very low corrosion, treatment for biological matter, scale, and corrosion must be used. Initially, many water treatment representatives felt the systems required far more chemical treatment than actually required. This was evidently because they were considering the "open" nature of the system to be a large surface area, with the associated large volume of chemical evaporation. Ahlgren (1987, 1989) provides details on water treatment for thermal storage systems. For further information, see [Chapter 48](#).

Cleaning. Starting with a clean system at start-up minimizes problems throughout the life of the system. Ahlgren (1987) provides the following list of major steps in preoperational cleaning:

1. Remove all extraneous loose debris, construction material, trash, and dirt from tanks, piping, filters, etc., before the system is filled. Removing as much dry material as possible prevents transfer to hard-to-reach portions of the system.
2. Flush the fill water pipeline separately to drain. If a new water line has been installed, be sure that rust and debris from it is not washed into the thermal storage system.
3. Fill the system with soft, clean, fresh water. Open all system valves and lines to get thorough, high-velocity recirculation.
4. Add prescribed cleaning chemicals to circulating water. Most cleaners are a blend of alkaline detergents, wetting agents, and dispersants. Be sure cleaning chemical is dissolved and distributed thoroughly so it does not settle out in one part of the system.
5. Circulate cleaning solution for manufacturer's recommended time, frequently 8 to 24 h. Check during recirculation for any plugging of filters, strainers, etc.
6. While water is recirculating at a high rate, open drain valves at the lowest points in the system and drain cleaning solution as rapidly as possible. Draining while under recirculation prevents settling of solids in remote portions of the system.
7. Open and inspect system for thoroughness of cleaning. Refill with water and start rinse recirculation. If significant amounts of contaminants are still present, repeat cleaning and draining procedure until clean.
8. When cleaning has been thoroughly accomplished, refill system with fresh water for recirculation rinse. Drain rinse water and add fresh makeup, repeating the process until all signs of cleaning chemicals have been removed.
9. System is now in a clean, unprotected state. Fill with makeup water and proceed with passivating to develop protective films on all metallic surfaces.

Caution: (1) Water containing any contaminants, detergent, or disinfectant must be drained to an appropriate site. Check with local authorities before draining the system. (2) Water should be treated as soon as possible after cleaning the system. Cleaning removes any protective films from equipment surfaces, leaving them susceptible to corrosion. Especially when there is an extended period between cleaning and system start-up, corrosion and biofouling can become significant problems if water treatment is not initiated promptly.

Open Systems. Water treatment must be given close scrutiny in open systems. Although the evaporation and concentration of solids associated with cooling towers does not occur, the water may be saturated with air, so the corrosion potential is greater than in a closed system. Treatment against algae, scale, and corrosion must be provided. Water treatment must be operational immediately after cleaning. Corrosion coupon assemblies should be included to monitor treatment effectiveness. Water testing and service should be performed at least once a month, preferably weekly immediately following initial start-up, by the water treatment supplier.

Systems open to the atmosphere require periodic applications of a biocide. Potable water is usually of acceptable quality for storage tanks that are filled at the installation site. Where the water is in contact with either a metallic heat exchanger or tank, additional treatment may be needed to regulate pH, chlorides, or other water quality parameters.

Closed Systems. The secondary coolant should be pretreated by the supplier. A complete analysis should be done annually. Monthly checks on the solution concentration should be made using a refractive indicator. (Automotive-type testers are not suitable.) For normal use, the solution should be good for many years without adding new inhibitors. However, provision should be made for injection of new inhibitors through a shot feeder if recommended by the manufacturer. The need for filtering, whether by including a filtering system or filtering the water or solution before it enters the system, should be carefully considered. Combination filter/feeders

and corrosion coupon assemblies may be needed to monitor the effect of the solution on the copper and steel in the system.

COMMISSIONING

Commissioning is a process whereby all of the subsystems and components of the system are incorporated into a whole system that functions according to the design intent. The complete commissioning process, as outlined in ASHRAE *Guideline 1*, begins in the program phase and lasts through training of the building operators and the first year of operation of the building. Commissioning strives for improved communication among parties to the design procedure, providing for clear definition of the functional needs of the HVAC system, and documentation of design criteria, assumptions, and decisions.

Cool storage systems can especially benefit from commissioning. Some storage systems, particularly partial-storage systems, may have less reserve cooling capacity than nonstorage systems. A nonstorage system has excess capacity in every hour that is not a design hour. Storage systems benefit from the use of stored cooling to achieve a closer match of total capacity to total load. These benefits are achieved at the price of some additional complexity to control the inventory of stored cooling, and a reduced safety factor. Therefore, there is a need for increased care in design, installation, and operation, which the commissioning process helps to ensure.

Commissioning should also provide documentation of actual system capacities, which allows control strategies to be optimized to take full advantage of system capabilities.

Additional information on the commissioning process is given in [Chapter 42](#), and detailed information on commissioning and performance testing for cool storage systems is provided in ASHRAE *Guideline 1* and *Standard 150*, and by Elleson (1997).

Statement of Design Intent

The statement of design intent defines in detail the performance requirements of the cool storage system. It is the master reference document that shapes all future work and is the benchmark by which success of the project is judged. The process of defining the design intent should begin as early as possible in the program phase, and continue throughout the design phase.

The initial statement of design intent is prepared from information developed in the owner's program and the results of the feasibility study. It describes the facility's functional needs, as well as the owner's requirements for environmental control and system performance. These items include

- Temperature and relative humidity requirements
- Cooling load parameters
- Acceptable hours (if any) that loads may exceed system capacity
- Occupancy schedules
- Reliability or redundancy requirements
- Needs for operational flexibility
- Financial criteria
- Energy performance criteria
- Demand shift

During the design phase, the following items are added:

- Narrative description of the system
- Performance goals for energy consumption and electric demand
- Hourly operating profile for design day and minimum-load day
- Schematic diagram of piping system, including cool storage system
- Description of control strategies for all possible modes and conditions

As the design develops, these items are refined and expanded, so the final statement of design intent provides a detailed description of the intended configuration, operation, and control of the system.

Commissioning Specification

The commissioning specification defines the contractual relationships by which the final system is brought into conformance with the design intent. It delineates the responsibilities of each party; specifies the requirements for construction observation, start-up, and acceptance testing; and defines the criteria by which the performance of the system is evaluated.

ASHRAE *Guideline* 1 provides additional details on and a sample of a commissioning specification.

Required Information

Certain system-specific design information must be assembled before running performance tests. These data are required to determine the test conditions and requirements for a specific system. The following information must be supplied:

- Load profile against which storage device or system is to be tested
- Tests to be performed; users may elect to perform one or more individual tests
- Boundary of system or portion of system to be tested by system capacity test
- Components with energy inputs to be included in system efficiency test
- System parameters, such as
 - Maximum usable discharge temperature
 - Maximum usable cooling supply temperature
 - Criteria for determining fully charged and fully discharged conditions
 - Maximum amount of time available for charging storage

Much of this information is normally defined in the statement of design intent.

Performance Verification

Before performance testing, verification should confirm that each component has been installed properly and that all individual components, equipment, and systems actually function in accordance with the contract documents and with the manufacturers' specifications. This verification should include items such as the following:

- Chillers maintain correct set points for each operating mode.
- Chiller capacity is within specified tolerances.
- Pumps, valves, and chillers sequence correctly in each operating mode and when changing between modes.
- Glycol concentration is as specified.
- Storage tank inlet and outlet temperatures are correct during both charging and discharging modes.
- Controllers and control valves and dampers maintain temperature set points.
- Flow switches function correctly.
- Flow rates are as reported in testing, adjusting, and balancing (TAB) report.
- Flow meters and temperature sensors report accurate measurements.
- Pressure-sustaining valve maintains correct pressure.
- Heat exchangers provide and maintain specified differential temperatures.
- Freeze protection sequence operates correctly.

Functional performance testing demonstrates that performance of the system as a whole satisfies the statement of design intent and contract documents. The functional performance test determines whether all components of the system function together, as designed, to meet the cooling load while satisfying the targets for electric demand and energy consumption. Functional performance testing is intended to answer basic questions such as the following:

- Does system function according to statement of design intent?

- Does system meet each hour's instantaneous load, at required fluid temperature?
- What is usable storage capacity of the storage tanks?
- What is available system capacity to meet the load, instantaneous and average for the day?
- What is system's efficiency in meeting the load, instantaneous and average for the day?
- What is daily tank standby loss?
- What is chiller capacity in charge mode and in direct cooling mode?

Functional performance testing also helps establish the final operating set points for control parameters such as chiller demand limit, ice-making cutout temperature, etc.

Because the performance of a cool storage system depends on the load to which it is subjected, the system must be tested with a design cooling load profile, or an equivalent profile.

ASHRAE *Standard* 150 provides detailed test methods for accurately determining a system's ability to meet a given cooling load. The standard requires some documentation before a performance test is carried out, including the design load profile, criteria for determining the fully charged and fully discharged conditions, and a schematic diagram of the system illustrating intended measuring points. This standard defines procedures for determining the charge and discharge capacities of a storage device and the total capacity and efficiency of the entire system. The starting and ending points for the performance tests are defined in terms of two distinctive states of charge: fully charged and fully discharged.

The **fully charged** condition is the state at which, according to the design, no more heat is to be removed from the tank. This state is generally reached when the control system stops the charge cycle as part of its normal control sequence, or when the maximum allowable charging period has elapsed.

The **fully discharged** condition is the state at which no more usable cooling capacity can be recovered from the tank. This condition is reached when the fluid temperature leaving the tank rises above the maximum usable chilled-water supply temperature.

Performance testing of cool storage systems tends to be more susceptible to sensor errors than testing of nonstorage systems, because data must be collected and accumulated over an extended time. Sensor accuracy should be verified in the field, particularly when the results of performance tests will have contractual or financial implications. Elleson et al. (2002) discuss verifying sensor accuracy.

Sample Commissioning Plan Outline for Chilled-Water Plants with Thermal Storage Systems

The following is an outline of a generic commissioning plan for cool storage systems.

- A. Identify owner project requirements (OPR).
 1. Site objectives.
 2. Functional uses and operational capabilities.
 3. Indoor environmental requirements.
 4. Environmental and utility cost, and energy and demand savings goals.
 5. Level of control desired.
 6. Training expectations.
 7. Expected/current capabilities of owner's O&M staff.
 8. Include specific measurement performance criteria, such as discharge rate, daily cooling capacity available from storage, capacity shifted from peak to off-peak, and average daily plant performance (be explicit as to what equipment is to be included).
 9. If project is a retrofit, identify current systems and their operating schedules.

- B. Identify economic assumptions; perform economic feasibility analysis.
- C. Identify approximate schedule of operation.
- D. Define expected scope of commissioning services, systems, and equipment included, as well as commissioning team members.
- E. Conduct commissioning kick-off meeting: establish schedule for future meeting; discuss how performance criteria are to be verified, monitored, and maintained.
- F. Develop design intent document (OPR).
- G. Conduct design review: focus on adherence to OPR, and efficacy of design parameters, including design load profile, clarity of control sequence descriptions, and maintainability of design.
- H. Develop/review commissioning related specifications: include project-specific training requirements and required programming of operational block trends.
- I. Conduct prebid meeting: identify commissioning requirements and expectations with potential bidders.
- J. Review submittal for adherence to specification and OPR.
- K. Negotiate desired exceptions to specification.
- L. Prepare site specific checks and test procedures. Potential checks and tests to consider include
 1. Verify proper placement and calibration of critical sensors.
 2. Verify proper setup of valve and damper actuators.
 3. Verify proper programming of schedules, set points, key sequences of control, and graphics. Verify proper implementation of sensor calibration parameters and PID loop tuning parameters.
 4. Verify communication speeds, system response times, and maximum trending capability.
 5. Use operational trends to verify proper operation of economizers, set points, schedules, and staging.
 6. Specialized checks and tests include
 - Verify proper concentration of secondary coolant
 - Restart after power outage
 - Chiller capacity
 - Cooling capacity available from storage
 - Daily plant performance
- M. Review operational block trend data. Program new trends as necessary. Conduct installation checks and functional testing. Develop summary of activities and key findings in problem log format. Discuss results with client and contractor. After contractor has made necessary corrections, review corrections and retest as necessary. Note that costs for retesting should be obligation of contractor.
- N. Review as-builts and O&M documentation: be sure that clear operating plan is developed and available to operating staff.
- O. Conduct/participate in/verify/document facilities staff and user training.
- P. Prepare commissioning report: identify unresolved issues.
- Q. Prepare systems manual.
- R. Complete off-season testing and update systems manual with relevant operation and maintenance information as required.
- S. Conduct one-year warranty review.
- T. Conduct project wrap-up meeting. Finalize accountability requirements for maintaining performance.

GOOD PRACTICES

Elleson (1997) explored factors determining the success of cool storage systems and identified the following actions that contribute to successful systems:

- Calculating an accurate load profile
 - Using an hourly operating profile to size and select equipment
 - Developing a detailed description of the control strategy
 - Producing a schematic diagram
 - Producing a statement of design intent
 - Using safety factors with care
- Planning for performance monitoring
 - Producing complete design documents
 - Retaining an experienced cool storage engineer to review the design before bidding the project

A number of pitfalls were also identified that can jeopardize success:

- Owner not willing to commit resources to support high-quality design process
- Owner does not identify and communicate all requirements for cooling system early in project
- Economic value of project not presented in appropriate financial terms; project goes unfunded
- Project justified on basis of incomplete or inaccurate feasibility study
- Assumptions made in feasibility study not documented and not verified in design phase
- Design intent for system not updated as design progresses, or recorded in contract documents
- System design based on estimates and assumptions rather than on engineering analysis
- Design not reviewed by qualified, independent reviewer
- Complete description of intended control strategies is not included in specifications
- Performance testing not required in contract documents, or test requirements not adequately defined
- Equipment submittals not reviewed for required conformance with specifications, or inadequate equipment substituted to reduce costs
- Operation and maintenance personnel not included in design process, or operator training is neglected
- Owner not willing to complete acceptable level of commissioning before accepting system for day-to-day use
- Owner not willing to support qualified, well-trained staff to achieve optimum performance

REFERENCES

- Akbari, H., D. Samano, A. Mertol, F. Bauman, and R. Kammerud. 1986. The effect of variations in convection coefficients on thermal energy storage in buildings: Part 1—Interior partition walls. *Energy and Buildings* 9:195-211.
- Ahlgren, R.M. 1987. *Water treatment technologies for thermal storage systems*. EPRI EM-5545. Electric Power Research Institute, Palo Alto, CA.
- Ahlgren, R.M. 1989. Overview of water treatment practices in thermal storage systems. *ASHRAE Transactions* 95(2):963-968.
- Anderson, L.O., K.G. Bernander, E. Isfalt, and A.H. Rosenfeld. 1979. Storage of heat and cooling in hollow-core concrete slabs: Swedish experience and application to large, American style building. 2nd International Conference on Energy Use Management, Los Angeles.
- Andrepoint, J.S. 1992. Central chilled water plant expansions and the CFC refrigerant issue—Case studies of chilled-water storage. *Proceedings of the Association of Higher Education Facilities Officers 79th Annual Meeting*, Indianapolis, IN.
- Andrepoint, J.S. 1994. Performance and economics of CT inlet air cooling using chilled water storage. *ASHRAE Transactions* 100(1):587.
- Andrepoint, J.S. 2000. Long-term performance of a low temperature fluid in thermal storage and distribution applications. *Proceedings of the 13th Annual College/University Conference of the International District Energy Association*.
- Andrepoint, J.S. 2001. Combustion turbine inlet air cooling (CTIAC): Benefits and technology options in district energy applications. *ASHRAE Transactions* 107(1).
- Andrepoint, J.S. 2005. Developments in thermal energy storage: Large applications, low temps, high efficiency, and capital savings. *Proceedings of Association of Energy Engineers (AEE) World Energy Engineering Congress*, September.
- Andrepoint, J.S. 2006. Stratified low-temperature fluid thermal energy storage (TES) in a major convention district—Aging gracefully, as fine wine. *ASHRAE Transactions* 112(2).

- Andrepoint, J.S. and M.W. Kohlenberg. 2005. A campus district cooling system expansion: Capturing millions of dollars in net present value using thermal energy storage. *Proceedings of International District Energy Association (IDEA) 18th Annual Campus Energy Conference*, March.
- Andrepoint, J.S. and K.C. Rice. 2002. A case study of innovation and success: A 15 MW demand-side peaking power system. *Proceedings of POWER-GEN International*, December.
- Andresen, I. and M.J. Brandemuehl. 1992. Heat storage in building thermal mass: A parametric study. *ASHRAE Transactions* 98(1):910-918.
- ARI. 2002. Specifying the thermal performance of cool storage equipment. *Guideline T-2002*. Air-Conditioning and Refrigeration Institute, Arlington, VA.
- ARI. 2003. Performance rating of water-chilling packages using the vapor compression cycle. *Standard 550/590-2003*. Air-Conditioning and Refrigeration Institute, Arlington, VA.
- Arnold, D. 1978. Comfort air conditioning and the need for refrigeration. *ASHRAE Transactions* 84(2):293-303.
- ASHRAE. 1996. The HVAC commissioning process. *Guideline 1-1996*.
- ASHRAE. 1993. Preparation of operating and maintenance documentation for building systems. *Guideline 4-1993*.
- ASHRAE. 1981. Methods of testing thermal storage devices with electrical input and thermal output based on thermal performance. ANSI/ASHRAE *Standard 94.2-1981* (RA 96).
- ASHRAE. 1986. Methods of testing active sensible thermal energy storage devices based on thermal performance. ANSI/ASHRAE *Standard 94.3-1986* (RA 96).
- ASHRAE. 2000. Method of testing the performance of cool storage systems. ANSI/ASHRAE *Standard 150-2000* (RA 2004).
- ASME. Annual. *Boiler and pressure vessel codes*. American Society of Mechanical Engineers, New York.
- Bahnfleth, W.P. and W.S. Joyce. 1994. Energy use in a district cooling system with stratified chilled-water storage. *ASHRAE Transactions* 100(1):1767-1778.
- Bahnfleth, W. and C. Kirchner. 1999. Analysis of transfer pumping interfaces for stratified chilled-water thermal storage systems—Part 2: Parametric study. *ASHRAE Transactions* 105(1):19-40.
- Bahnfleth, W., J. Song, and J. Climbala. 2003a. Thermal performance of single pipe diffusers in stratified chilled-water storage tanks (RP-1185). ASHRAE Research Project, *Final Report*.
- Bahnfleth, W., G. McLeod, and S. Bowins. 2003b. Chilled-water storage in western Australia. *ASHRAE Transactions* 109(1):617-625.
- Balcomb, J.D. 1983. *Heat storage and distribution inside passive solar buildings*. Los Alamos National Laboratory, Los Alamos, NM.
- Borer, E. and J. Schwartz. 2005. High marks for chilled-water system: Princeton upgrades and expands. *District Energy* 91(1):14-18.
- Braun, J.E. 1990. Reducing energy costs and peak electrical demand through optimal control of building thermal storage. *ASHRAE Transactions* 96(2):876-888.
- Braun, J.E. 2003. Load control using building thermal mass. *ASME Journal of Solar Energy Engineering* 125:292-301.
- Braun, J.E., K.W. Montgomery, and N. Chaturvedi. 2001. Evaluating the performance of building thermal mass control strategies. *International Journal of HVAC&R* (now *HVAC&R Research*) 7(4):403-428.
- Caldwell, J. and W. Bahnfleth. 1997. Chilled-water storage feasibility without electric rate incentives or rebates. *ASCE Journal of Architectural Engineering* 3(3):133-140.
- Colliver, D.G., R.S. Gates, H. Zhang, and T. Priddy. 1998. Sequences of extreme temperature and humidity for design calculations (RP-828). *ASHRAE Transactions* 104(1):133-144.
- Conniff, J.P. 1991. Strategies for reducing peak air conditioning loads by using heat storage in the building structure. *ASHRAE Transactions* 97(1):704-709.
- Crane, J.M. 1991. The Consumer Research Association new office/laboratory complex, Milton Keynes: Strategy for environmental services. *CIBSE National Conference*, Canterbury, pp. 2-29.
- Cross, J.K., W. Beckman, J. Mitchell, D. Reindl, and D. Knebel. 1995. Modeling of hybrid combustion turbine inlet air cooling systems. *ASHRAE Transactions* 101(2):1335-1341.
- CSA. 1993. Design and construction of earth energy heat pump systems for commercial and institutional buildings. *Standard C447-93*. Canadian Standards Association, Rexdale, Ontario.
- Dorgan, C.E. and J.S. Elleson. 1993. *Design guide for cool thermal storage*. ASHRAE.
- Dorgan, C.B., C.E. Dorgan, and I.B.D. McIntosh. 1999. Cool storage operating and control strategies (RP-1054). ASHRAE Research Project, *Final Report*.
- Dorgan, C.B., C.E. Dorgan, and I.B.D. McIntosh. 2001. A descriptive framework for cool storage operating and control strategies (RP-1045). *ASHRAE Transactions* 107(1):93-101.
- Drees, K.H. 1994. *Modeling and control of area constrained ice storage systems*. M.S. thesis, Purdue University, West Lafayette, IN.
- Ebeling, J.A., L. Beaty, and S.K. Blanchard. 1994. Combustion turbine inlet air cooling using ammonia-based refrigeration for capacity enhancement. *ASHRAE Transactions* 100(1):583-586.
- Elleson, J.S. 1993. Energy use of fan-powered mixing boxes with cold air distribution. *ASHRAE Transactions* 99(1):1349-1358.
- Elleson, J.S. 1997. *Successful cool storage projects: From planning to operation*. ASHRAE.
- Elleson, J.S., J.S. Haberl, and T.A. Reddy. 2002. Field monitoring and data validation for evaluating the performance of cool storage systems. *ASHRAE Transactions* 108(1):1072-1084.
- Fiorino, D.P. 1994. Energy conservation with thermally stratified chilled-water storage. *ASHRAE Transactions* 100(1):1754-1766.
- Gansler, R.A., D.T. Reindl, and T.B. Jekel. 2001. Simulation of source energy utilization and emissions for HVAC systems. *ASHRAE Transactions* 107(1):39-51.
- Gatley, D.P. and Mackie, E.I. 1995. *Cool storage open hydronic systems design guide*. EPRI TR 104906. Electric Power Research Institute, Palo Alto, CA.
- Gatley, D.P. and J.J. Riticher. 1985. Successful thermal storage. *ASHRAE Transactions* 91(1B):843-855.
- Goss, J.O., L. Hyman, and J. Corbett. 1996. Integrated heating, cooling thermal energy storage with heat pump provides economic and environmental solutions at California State University, Fullerton. *EPRI International Conference on Sustainable Thermal Energy Storage*, pp. 163-167.
- Gute, G.D., W.E. Stewart, Jr., and J. Chandrasekharan. 1995. Modeling the ice-filling process of rectangular thermal energy storage tanks with multiple ice makers. *ASHRAE Transactions* 101(1):56-65.
- Hall, S.H. 1993. *Feasibility studies for aquifer thermal energy storage*. PNL-8364. Pacific Northwest Laboratory, Richland, WA.
- Henze, G.P., F. Clemens, and G. Knabe. 2004. Evaluation of optimal control for active and passive building thermal storage. *International Journal of Thermal Sciences* 43:173-181.
- Henze, G.P., D. Kalz, S. Liu, and C. Felsmann. 2005. Experimental analysis of model based predictive optimal control for active and passive building thermal storage inventory. *International Journal of HVAC&R Research* (now *HVAC&R Research*) 11(2):189-214.
- Herman, A.F.E. 1980. Underfloor, structural storage air-conditioning systems. *FRIGAIR '80 Proceedings*, Paper 7. Pretoria, South Africa.
- Hersh, H., G. Mirchandani, and R. Rowe. 1982. *Evaluation and assessment of thermal energy storage for residential heating*. ANL SPG-23. Argonne National Laboratory, Argonne, IL.
- Hittle, D.C. and T.R. Smith. 1994. Control strategies and energy consumption for ice storage systems using heat recovery and cold air distribution. *ASHRAE Transactions* 100(1):1221-1229.
- Holness, G.V.R. 1992. Case study of combined chilled water thermal energy storage and fire protection storage. *ASHRAE Transactions* 98(1):1119-1122.
- Hussain, M.A. and D.C.J. Peters. 1992. Retrofit integration of fire protection storage as chilled-water storage—A case study. *ASHRAE Transactions* 98(1):1123-1132.
- Jenne, E.A. 1992. Aquifer thermal energy (heat and chill) storage. Paper presented at the 1992 Intersociety Energy Conversion Engineering Conference, PNL-8381. Pacific Northwest Laboratory, Richland, WA.
- Keeney, K.R. and J.E. Braun. 1996. A simplified method for determining optimal cooling control strategies for thermal storage in building mass. *International Journal of HVAC&R Research* (now *HVAC&R Research*) 2(1):59-78.
- Kintner-Meyer, M. and A.F. Emery. 1995. Optimal control of an HVAC system using cold storage and building thermal capacitance. *Energy and Buildings* 23(1):19-31.
- Kirkpatrick, A.T. and J.S. Elleson. 1997. *Cold air distribution system design guide*. ASHRAE.
- Knebel, D.E. 1986. Thermal storage—A showcase on cost savings. *ASHRAE Journal* 28(5):28-31.

- Knebel, D.E. 1988. Economics of harvesting thermal storage systems: A case study of a merchandise distribution center. *ASHRAE Transactions* 94(1):1894-1904. Reprinted in *ASHRAE Technical Data Bulletin* 5(3): 35-39, 1989.
- Knebel, D.E. and S. Houston. 1989. Case study on thermal energy storage—The Worthington Hotel. *ASHRAE Journal* 31(5):34-42.
- Landry, C.M. and C.D. Noble. 1991. Case study of cost-effective low-temperature air distribution, ice thermal storage. *ASHRAE Transactions* 97(1):854-862.
- Liebendorfer, K.M. and J.S. Andrepont. 2005. Cooling the hot desert wind: Turbine inlet cooling with thermal energy storage (TES) increases net power plant output 30%. *ASHRAE Transactions* 111(2):545-550.
- MacCracken, C.D. 1994. An overview of the progress and the potential of thermal storage in off-peak turbine inlet cooling. *ASHRAE Transactions* 100(1):569-571.
- Mackie, E.I. 1994. Inlet air cooling for a combustion turbine using thermal storage. *ASHRAE Transactions* 100(1):572-582.
- Meckler, M. 1992. Design of integrated fire sprinkler piping and thermal storage systems: Benefits and challenges. *ASHRAE Transactions* 98(1): 1140-1148.
- Meierhans, R.A. 1993. Slab cooling and earth coupling. *ASHRAE Transactions* 99(2):511-518.
- Morgan, S. and M. Krarti. 2006. Impact of electricity rate structures on energy cost savings of pre-cooling controls for office buildings. *Energy and Buildings* 38.
- Morofsky, E. 1994. *Procedures for the environmental impact assessment of aquifer thermal energy storage*. PWC/RDD/106E. Environment Canada and Public Works and Government Canada, Ottawa.
- Morris, F.B., J.E. Braun, and S.J. Treado. 1994. Experimental and simulated performance of optimal control of building thermal storage. *ASHRAE Transactions* 100(1):402-414.
- Musser, A. and W. Bahnfleth. 1998. Evolution of temperature distributions in a full-scale stratified chilled-water storage tank. *ASHRAE Transactions* 104(1):55-67.
- Musser, A. and W. Bahnfleth. 1999. Field-measured performance of four full-scale cylindrical stratified chilled-water thermal storage tanks. *ASHRAE Transactions* 105(2):218-230.
- Musser, A. and W. Bahnfleth. 2001. Parametric study of charging inlet diffuser performance in stratified chilled-water storage tanks with radial diffusers: Part 2—Dimensional analysis, parametric simulations and simplified model development. *ASHRAE Transactions* 107(2):41-58.
- Nelson, K.P. 2000. Dynamic ice, low-cost alternative for new construction. *ASHRAE Transactions* 106(2):920-926.
- ORNL. 1985. *Field performance of residential thermal storage systems*. EPRI EM 4041. Oak Ridge National Laboratories.
- Public Works Canada. 1991. Workshop on generic configurations of seasonal cold storage applications. International Energy Agency, Energy Conservation Through Energy Storage Implementing Agreement (Annex 7). PWC/RDD/89E (September). Public Works Canada, Ottawa.
- Public Works Canada. 1992. *Innovative and cost-effective seasonal cold storage applications: Summary of national state-of-the-art reviews*. International Energy Agency, Energy Conservation Through Energy Storage Implementing Agreement (Annex 7). PWC/RDD/96E (June). Public Works Canada, Ottawa.
- Rabl, A. and L.K. Norford. 1991. Peak load reduction by preconditioning buildings at night. *International Journal of Energy Research* 15:781-798.
- Reindl, D.T., D.E. Knebel, and R.A. Gansler. 1995. Characterizing the marginal basis source energy and emissions associated with comfort cooling systems. *ASHRAE Transactions* 101(1):1353-1363.
- Ruud, M.D., J.W. Mitchell, and S.A. Klein. 1990. Use of building thermal mass to offset cooling loads. *ASHRAE Transactions* 96(2):820-828.
- Simmonds, P. 1991. The utilization and optimization of a building's thermal inertia in minimizing the overall energy use. *ASHRAE Transactions* 97(2):1031-1042.
- Snijders, A.L. 1992. Aquifer seasonal cold storage for space conditioning: Some cost-effective applications. *ASHRAE Transactions* 98(1):1015-1022.
- Stewart, W.E., G.D. Gute, J. Chandrasekharan, and C.K. Saunders. 1995a. Modeling of the melting process of ice stores in rectangular thermal energy storage tanks with multiple ice openings. *ASHRAE Transactions* 101(1):56-65.
- Stewart, W.E., G.D. Gute, and C.K. Saunders. 1995b. Ice melting and melt water discharge temperature characteristics of packed ice beds for rectangular storage tanks. *ASHRAE Transactions* 101(1):79-89.
- Stewart, W.E. 1999. *Design guide for combustion turbine inlet air cooling systems*. ASHRAE.
- Stewart, W.E. 2000. Improved fluids for naturally stratified chilled-water storage systems. *ASHRAE Transactions* 106(1).
- Stewart, W.E. 2001. Operating characteristics of five stratified chilled-water thermal storage tanks. *ASHRAE Transactions* 107(2):12-21.
- Stovall, T.K. 1991. *Turbo Refrigerating Company ice storage test report*. ORNL/TM-11657. Oak Ridge National Laboratory, Oak Ridge, TN.
- Tamblyn, R.T. 1985. College Park thermal storage experience. *ASHRAE Transactions* 91(1B):947-951.
- Tran, N., J.F. Kreider, and P. Brothers. 1989. Field measurements of chilled-water storage thermal performance. *ASHRAE Transactions*. 95(1):1106-1112.
- Wildin, M.W. 1991. *Flow near the inlet and design parameters for stratified chilled-water storage*. ASME 91-HT-27. American Society of Mechanical Engineers, New York.
- Wildin, M.W. 1996. Experimental results from single-pipe diffusers for stratified thermal energy storage. *ASHRAE Transactions* 102(2): 123-132.
- Wildin, M.W. and C.R. Truman. 1989. Performance of stratified vertical cylindrical thermal storage tanks—Part 1: Scale model tank. *ASHRAE Transactions* 95(1):1086-1095.
- Willis, S. and J. Wilkins. 1993. Mass appeal. *Building Services Journal* 15(1):25-27.
- Yoo, J., M. Wildin, and C.W. Truman. 1986. Initial formation of a thermocline in stratified thermal storage tanks. *ASHRAE Transactions* 92(2A): 280-290.

BIBLIOGRAPHY

- Arnold, D. 1999. Building mass cooling—Case study of alternative slab cooling strategies. *Engineering in the 21st Century—The Changing World*, CIBSE National Conference, Harrogate, pp. 136-144.
- Arnold, D. 2000. Thermal storage case study: Combined building mass and cooling pond. *ASHRAE Transactions* 106(1):819-827.
- ASHRAE. 2000. Specifying direct digital control systems. *Guideline* 13-2000.
- ASHRAE. 2004. Safety standard for mechanical refrigeration. ANSI/ASHRAE Standard 15-2004.
- Athienitis, A.K. and T.Y. Chen. 1993. Experimental and theoretical investigation of floor heating with thermal storage. *ASHRAE Transactions* 99(1):1049-1060.
- Bellecci, C. and M. Conti. 1993. Transient behaviour analysis of a latent heat thermal storage module. *International Journal of Heat and Mass Transfer* 36(15):38-51.
- Benjamin, C.S. 1994. Chilled-water storage at Washington State University: A case study. *Proceedings of the Eighty-Fifth Annual Conference of the International District Heating and Cooling Association*, pp. 330-341.
- Berglund, L.G. 1991. Comfort benefits for summer air conditioning with ice storage. *ASHRAE Transactions* 97(1):843-847.
- Bhansali, A. and D.C. Hittle. 1990. Estimated energy consumption and operating cost for ice storage systems with cold air distribution. *ASHRAE Transactions* 96(1):418-427.
- Brady, T.W. 1994. Achieving energy conservation with ice-based thermal storage. *ASHRAE Transactions* 100(1):1735-1745.
- Cai, L., W.E. Stewart, Jr., and C.W. Sohn. 1993. Turbulent buoyant flows into a two-dimensional storage tank. *International Journal of Heat and Mass Transfer* 36(17):4247-4256.
- Cao, Y. and A. Faghri. 1992. A study of thermal energy storage systems with conjugate turbulent forced convection. *Journal of Heat Transfer* 114(4): 10-19.
- Dorgan, C.E. and C.B. Dorgan. 1995. *Cold air distribution design guide*. TR-105604. Electric Power Research Institute, Palo Alto, CA.
- Ebeling, J.A., L. Beaty, and S.K. Blanchard. 1994. Combustion turbine inlet air cooling using ammonia-based refrigeration for capacity enhancement. *ASHRAE Transactions* 100(1):583-586.
- Fiorino, D.P. 1991. Case study of a large, naturally stratified, chilled-water thermal energy storage system. *ASHRAE Transactions* 97(2):1161-1169.
- Fiorino, D.P. 1992. Thermal energy storage program for the 1990s. *Energy Engineering* 89(4):23-33.
- Gallagher, M.W. 1991. Integrated thermal storage/life safety systems in tall buildings. *ASHRAE Transactions* 97(1):833-838.
- Gateley, D.P. 1992. *Cool storage ethylene glycol design guide*. TR-100945. Electric Power Research Institute, Palo Alto, CA.

- Gillespe, K.L., S.L. Blanc, and S. Parker. 1999. Performance of a hotel chilled water plant with cool storage. *ASHRAE Transactions* 99(2):SE-99-18-01.
- Goncalves, L.C.C. and S.D. Probert. 1993. Thermal energy storage: Dynamic performance characteristics of cans each containing a phase-change material, assembled as a packed bed. *Applied Energy* 45(2):117.
- Gretarsson, S.P., C.O. Pedersen, and R.K. Strand. 1994. Development of a fundamentally based stratified thermal storage tank model for energy analysis calculations. *ASHRAE Transactions* 100(1):1213-1220.
- Guven, H. and J. Flynn. 1992. Commissioning TES systems. *Heating/Piping/Air Conditioning* (January):82-84.
- Hall, S.H. 1993. *Environmental risk assessment for aquifer thermal energy storage*. PNL-8365. Pacific Northwest Laboratory, Richland, WA.
- Harmon, J.J. and H.C. Yu. 1989. Design considerations for low-temperature air distribution systems. *ASHRAE Transactions* 95(1):1295-1299.
- Harmon, J.J. and H.C. Yu. 1991. Centrifugal chillers and glycol ice thermal storage units. *ASHRAE Journal* 33(12):25-31.
- Hensel, E.C. Jr., N.L. Robinson, J. Buntain, J.W. Glover, B.D. Birdsell, and C.W. Sohn. 1991. Chilled-water thermal storage system performance monitoring. *ASHRAE Transactions* 97(2):1151-1160.
- Henze, G.V.R., M. Krarti, and M.J. Brandemuehl. 2003. Guidelines for improved performance of ice storage systems. *Energy and Buildings* 35(2):111-127.
- Ihm, P., M. Krarti, and G.P. Henze. 2004. Development of a thermal energy storage model for EnergyPlus. *Energy and Buildings*, 36(8):807-808.
- Jekel, T.B., J.W. Mitchell, and S.A. Klein. 1993. Modeling of ice-storage tanks. *ASHRAE Transactions* 99(1):1016-1024.
- Kamel, A.A., M.V. Swami, S. Chandra, and C.W. Sohn. 1991. An experimental study of building-integrated off-peak cooling using thermal and moisture (enthalpy) storage systems. *ASHRAE Transactions* 97(2):240-244.
- Kirshenbaum, M.S. 1991. Chilled water production in ice-based thermal storage systems. *ASHRAE Transactions* 97(2):422-427.
- Kleinbach, E., W. Beckman, and S. Klein. 1993. Performance study of one-dimensional models for stratified thermal storage tanks. *Solar Energy* 50(2):155.
- Knebel, D.E. 1988. Optimal control of harvesting ice thermal storage systems. *AICE Proceedings*, 1990, pp. 209-214.
- Knebel, D.E. 1991. *Optimal design and control of ice harvesting thermal energy storage systems*. ASME 91-HT-28. American Society of Mechanical Engineers, New York.
- MacCracken, M.M. 2003. Thermal energy storage myths. *ASHRAE Journal* 45(9):36-43.
- Mirth, D.R., S. Ramadhyani, and D.C. Hittle. 1993. Thermal performance of chilled water cooling coils operating at low water velocities. *ASHRAE Transactions* 99(1):43-53.
- Molson, J.W., E.O. Frind, and C.D. Palmer. 1992. Thermal energy storage in an unconfined aquifer—II: Model development, validation, and application. *Water Resources Research* 28(10):28-57.
- Potter, R.A., D.R. Weitzel, D.J. King, and D.D. Boettner. 1995. Study of operational experience with thermal storage systems (RP-766). *ASHRAE Transactions* 101(2):549-557.
- Prusa, J., G.M. Maxwell, and K.J. Timmer. 1991. A mathematical model for a phase-change, thermal energy storage system using rectangular containers. *ASHRAE Transactions* 97(2):245-261.
- Rogers, E.C. and B.A. Stefl. 1993. Ethylene glycol: Its use in thermal storage and its impact on the environment. *ASHRAE Transactions* 99(1):941-949.
- Ruchti, T.L., K.H. Drees, and G.M. Decious. 1996. Near optimal ice storage system controller. *EPRI international Conference on Sustainable Thermal Energy Storage*, pp. 92-98.
- Rudd, A.F. 1993. Phase-change material wallboard for distributed thermal storage in buildings. *ASHRAE Transactions* 99(2):339-346.
- Rumbaugh, J., M. Blaha, W. Premerlani, F. Eddy, and W. Lorenzen. 1991. *Object-oriented modeling and design*. Prentice Hall, Englewood Cliffs, NJ.
- Silvetti, B. 2002. Application fundamentals of ice-based thermal storage. *ASHRAE Journal* 44(2):30-35.
- Simmonds, P. 1994. A comparison of energy consumption for storage-priority and chiller-priority for ice-based thermal storage systems. *ASHRAE Transactions* 100(1):1746-1753.
- Slabodkin, A.L. 1992. Integrating an off-peak cooling system with a fire suppression system in an existing high-rise office building. *ASHRAE Transactions* 98(1):1133-1139.
- Snyder, M.E. and T.A. Newell. 1990. Cooling cost minimization using building mass for thermal storage. *ASHRAE Transactions* 96(2):830-838.
- Sohn, C.W., D.M. Underwood, and M. Lin. 2006. An ice-ball storage cooling system for laboratory complex. *ASHRAE Transactions* 112(2).
- Sohn, C.W. and J. Nixon. 2001. A long-term experience with an external-melt ice-on-coil storage cooling system. *ASHRAE Transactions* 107(1):532-537.
- Sohn, C.W., J. Fuchs, and M. Gruber. 1999. Chilled-water storage cooling system for an Army installation. *ASHRAE Transactions*. 105(2):1126-1133.
- Sohn, M.S., J. Kaur, and R.L. Sawhney. 1992. Effect of storage on thermal performance of a building. *International Journal of Energy Research* 16(8):697.
- Somasundaram, S., D. Brown, and K. Drost. 1992. Cost evaluation of diurnal thermal energy storage for cogeneration applications. *Energy Engineering* 89(4):8.
- Sozen, M., K. Vafai, and L.A. Kennedy. 1992. Thermal charging and discharging of sensible and latent heat storage packed beds. *Journal of Thermophysics and Heat Transfer* 5(4):623.
- Stovall, T.K. 1991. *Baltimore Aircoil Company (BAC) ice storage test report*. ORNL/TM-11342. Oak Ridge National Laboratory, Oak Ridge, TN.
- Stovall, T.K. 1991. *CALMAC ice storage test report*. ORNL/TM-11582. Oak Ridge National Laboratory, Oak Ridge, TN.
- Strand, R.K., C.O. Pedersen, and G.N. Coleman. 1994. Development of direct and indirect ice-storage models for energy analysis calculations. *ASHRAE Transactions* 100(1):1230-1244.
- Tamblyn, R.T. 1985. Control concepts for thermal storage. *ASHRAE Transactions* 91(1B):5-11. Reprinted in *ASHRAE Technical Data Bulletin: Thermal Storage* 1985 (January):1-6. Also reprinted in *ASHRAE Journal* 27(5):31-34.
- Tamblyn, R.T. 1990. Optimizing storage savings. *Heating/Piping/Air Conditioning* (August):43-46.
- Wildin, M.W., E.I. Mackie, and W.E. Harrison. 1990. Thermal storage forum—Stratified thermal storage: A new/old technology. *ASHRAE Journal* 32(4):29-39.
- Wildin, M.W. 1990. Diffuser design for naturally stratified thermal storage. *ASHRAE Transactions* 96(1):1094-1102.

[Related Commercial Resources](#)