

CHAPTER 44

BUILDING AIR INTAKE AND EXHAUST DESIGN

[Exhaust Stack and Air Intake Design Strategies](#)..... 44.1
[Geometric Method for Estimating Stack Height](#)..... 44.5
[Exhaust-To-Intake Dilution Calculations](#)..... 44.6

FRESH air enters a building through its air intake. Likewise, building exhausts remove air contaminants from a building so wind can dilute the emissions. If the intake or exhaust system is not well designed, contaminants from nearby outside sources (e.g., vehicle exhaust) or from the building itself (e.g., laboratory fume hood exhaust) can enter the building with insufficient dilution. Poorly diluted contaminants may cause odors, health impacts, and reduced indoor air quality. This chapter discusses proper design of exhaust stacks and placement of air intakes to avoid adverse air quality impacts. Chapter 16 of the 2005 ASHRAE Handbook—Fundamentals more fully describes wind and airflow patterns around buildings. Related information can also be found in Chapters 7, 15, 30, 31, and 32 of this volume, Chapters 12 and 13 of the 2005 ASHRAE Handbook—Fundamentals, and Chapters 24, 25, and 30 of the 2004 ASHRAE Handbook—HVAC Systems and Equipment.

EXHAUST STACK AND AIR INTAKE DESIGN STRATEGIES

Stack Design Strategies

The dilution a stack exhaust can provide is limited by the dispersion capability of the atmosphere. Before discharge, exhaust contamination should be reduced by filters, collectors, and scrubbers.

Central exhausts that combine flows from many collecting stations should always be used where safe and practical. By combining several exhaust streams, central systems dilute intermittent bursts of contamination from a single station. Also, the combined flow forms an exhaust plume that rises a greater distance above the emitting building. Additional air volume can be added to the exhaust near the exit with a makeup air unit to increase initial dilution and exhaust plume rise. This added air volume does not need heating or cooling, saving on energy costs.

In some cases, separate exhaust systems are mandatory. The nature of the contaminants to be combined, recommended industrial hygiene practice, and applicable safety codes need to be considered. Separate exhaust stacks could be grouped in a tight cluster to take advantage of the larger plume rise of the resulting combined jet. Also, a single stack location for a central exhaust system or a tight cluster of stacks allows building air intakes to be positioned as far as possible from the exhaust. For a tight cluster to be considered as a single stack in dilution calculations, the stacks must be uncapped, have approximately the same exhaust velocities, and all lie within a two-stack diameter radius of the middle of the group. Stacks lined up in a row do not act as a single stack (Gregoric et al. 1982).

As shown in Figure 1, stack height h_s is measured above the roof level on which the air intake is located. Wilson and Winkel (1982) demonstrated that stacks terminating below the level of adjacent walls and architectural enclosures frequently do not effectively reduce roof-level exhaust contamination. To take full advantage of their height, stacks should be located on the highest roof of a building.

Architectural screens used to mask rooftop equipment adversely affect exhaust dilution, depending on porosity, relative height, and

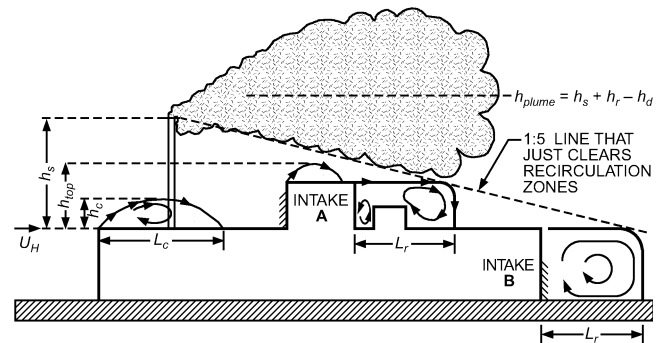

Fig. 1 Flow Recirculation Regions and Exhaust Parameters (Wilson 1982)

distance from the stack. Petersen et al. (1999) found that exhaust dispersion improves with increased screen porosity.

Large buildings, structures, and terrain close to the emitting building can adversely affect stack exhaust dilution, because the emitting building can be within the recirculation flow zones downwind of these nearby flow obstacles (Wilson et al. 1998a). In addition, an air intake located on a nearby taller building can be contaminated by exhausts from the shorter building. Wherever possible, facilities emitting toxic or highly odorous contaminants should not be located near taller buildings or at the base of steep terrain.

As shown in Figure 2, stacks should be vertically directed and uncapped. Stack caps that deflect the exhaust jet have a detrimental effect on exhaust plume rise. Small conical stack caps often do not completely exclude rain, because rain does not usually fall straight down; periods of heavy rainfall are often accompanied by high winds that deflect raindrops under the cap and into the stack (Changnon 1966). A stack exhaust velocity V_e of about 2500 fpm prevents condensed moisture from draining down the stack and keeps rain from entering the stack. For intermittently operated systems, protection from rain and snow should be provided by stack drains, as shown in Figure 2F to 2J, rather than stack caps.

Recommended Stack Exhaust Velocity

High stack exhaust velocity and temperatures increase plume rise, which tends to reduce intake contamination. Exhaust velocity V_e should be maintained above 2000 fpm (even with drains in the stack) to provide adequate plume rise and jet dilution. Velocities above 2000 fpm provide still more plume rise and dilution, but above 3000 to 4000 fpm, noise and vibration from exhaust fans become an important concern. An exit nozzle (Figure 2B) can be used to increase exhaust velocity and plume rise. Many laboratory fume hood systems use variable-volume fans that reduce flow from hoods when they are closed. Stack exhaust velocity calculation must be based on the minimum total flow rate from the system, not the maximum.

An exception to these exhaust velocity recommendations may be when corrosive condensate droplets are discharged. In this case, a velocity of 1000 fpm in the stack and a condensate drain are recommended to reduce droplet emission. At this low exhaust velocity, a

The preparation of this chapter is assigned to TC 4.3, Ventilation Requirements and Infiltration.

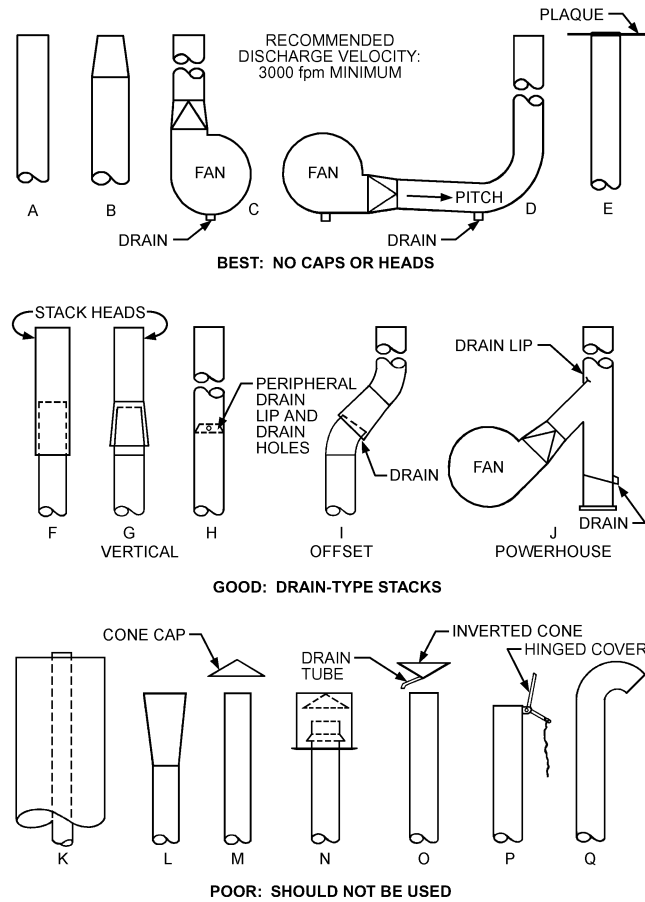

Fig. 2 Stack Designs Providing Vertical Discharge and Rain Protection

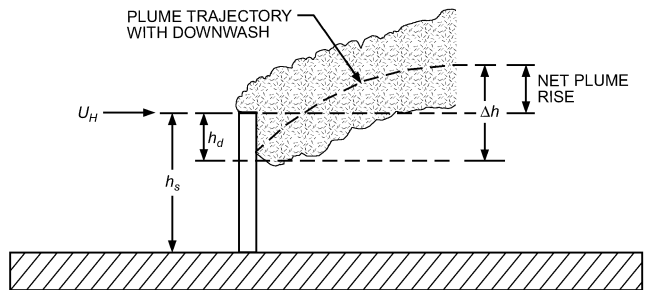

Fig. 3 Reduction of Effective Stack Height by Stack Wake Downwash

taller stack may be needed to counteract downwash caused by low exit velocity.

Stack wake downwash occurs where low-velocity exhausts are pulled downward by negative pressures immediately downwind of the stack, as shown in [Figure 3](#). V_e should be at least 1.5 times the design speed U_H at roof height in the approach wind to avoid stack wake downwash. A meteorological station design wind speed U_{met} that is exceeded less than 1% of the time can be used. This value can be obtained from Chapter 28 of the 2005 *ASHRAE Handbook—Fundamentals*, or estimated by applying Table 2 of Chapter 16 of that volume to annual average wind speed. Because wind speed increases with height, a correction for roof height should be applied for buildings significantly higher than 30 ft, using Equation (4) and Table 1 of Chapter 16 of the 2005 *ASHRAE Handbook—Fundamentals*.

Other Stack Design Standards

Minimum heights for chimneys and other flues are discussed in the *International Building Code (ICC 2006)*. For laboratory fume hood exhausts, American Industrial Hygiene Association (AIHA) *Standard Z9.5* recommends a minimum stack height of 10 ft above the adjacent roof line, an exhaust velocity V_e of 3000 fpm, and a stack height extending one stack diameter above any architectural screen; National Fire Protection Association (NFPA) *Standard 45* specifies a minimum stack height of 10 ft to protect rooftop workers. Toxic chemical emissions may also be regulated by federal, state, and local air quality agencies.

Air Intake Locations to Minimize Contamination

Carefully placed outside air intakes can reduce stack height requirements and help maintain acceptable indoor air quality. Rock and Moylan (1999) review recent literature on air intake locations and design. Petersen and LeCompte (2002) also showed the benefit of placing air intakes on building sidewalls.

ASHRAE *Standard 62.1-2004* highlights the need to locate makeup air inlets and exhaust outlets to avoid contamination.

Outside contamination sources to consider include the following:

Toxic Stack Exhausts. Boilers, emergency generators, and laboratory fume hoods are some sources that can seriously affect building indoor air quality because of toxic air pollutants. These sources, especially diesel-fueled emergency generators, can also produce strong odors that may require administrative measures, such as generator testing during low building occupancy or temporarily closing the intakes.

Automobile and Truck Traffic. Heavily traveled roads and parking garages emit carbon monoxide, dust, and other pollutants. Diesel trucks and ambulances are common sources of odor complaints (Smeaton et al. 1991). Intakes near vehicle loading zones should be avoided. Overhead canopies on vehicle docks do not prevent hot vehicle exhaust from rising to intakes above the canopy. When the loading zone is in the flow recirculation region downwind from the building, vehicle exhaust may spread upwind over large sections of the building surface (Ratcliff et al. 1994). Garbage containers may also be a source of odors, and garbage trucks may emit diesel exhaust with strong odors.

Kitchen Cooking Hoods. Kitchen exhaust can be a source of odors and cause plugging and corrosion of heat exchangers. Grease hoods have stronger odors than other general kitchen exhausts. Grease and odor removal equipment beyond that for code requirements may be needed if air intakes cannot be placed far away.

Evaporative Cooling Towers. Outbreaks of Legionnaires' disease have been linked to bacteria in cooling tower drift droplets being drawn into the building through air intakes (Puckorius 1999). ASHRAE *Guideline 12* gives advice on cooling tower maintenance for minimizing the risk of Legionnaires' disease, and suggests keeping cooling towers as far away as possible from intakes, operable windows, and outside public areas. No specific minimum separation distance is provided or available. Prevailing wind directions should also be considered to minimize risk. Evaporative cooling towers can have several other effects: water vapor can increase air-conditioning loads, condensing and freezing water vapor can damage equipment, and ice can block intake grilles and filters. Chemicals added to retard scaling and biological contamination may be emitted from the cooling tower, creating odors or health effects, as discussed by Vanderheyden and Schuyler (1994).

Building General Exhaust Air. General indoor air that is exhausted will normally contain elevated concentrations of carbon dioxide, dust, copier toner, off-gassing from materials, cleaning agents, and body odors. General exhaust air should not be allowed to reenter the building without sufficient dilution.

Stagnant Water Bodies, Snow, and Leaves. Stagnant water bodies can be sources of objectionable odors and potentially harmful organisms. Poor drainage should be avoided on the roof or ground near the intake. Restricted airflow from snow drifts, fallen leaves, and other debris can be avoided in the design stage with elevated louvers above ground or roof level.

Rain and Fog. Direct intake of rain and fog can increase growth of microorganisms in the building. AMCA (2003) recommends selecting louvers and grilles with low rain penetration and installing drains just inside the louvers and grilles. In locations with chronic fog, some outside air treatment is recommended. One approach is to recirculate some part of the indoor air to evaporate entrained water droplets, even during full air-side economizer operation (maximum outside air use).

Environmental Tobacco Smoke. Outside air intakes should not be placed close to outside smoking areas.

Plumbing Vents. Codes frequently require a minimum distance between plumbing vents and intakes to avoid odors.

Smoke from Fires. Smoke from fires is a significant safety hazard because of its direct health effects and from reduced visibility during evacuation. NFPA *Standard 92A* discusses the need for good air intake placement relative to smoke exhaust points.

Construction. Construction dust and equipment exhaust can be a significant nuisance over a long period. Temporary preconditioning of outside air is necessary in such situations, but is rarely provided. A simple solution is to provide room and access to the outside air duct for adding temporary air treatment filters or other devices, or a sufficient length of duct so that such equipment could be added when needed. Intake louvers and outside air ducts also require more frequent inspections and cleaning when construction occurs nearby.

Vandalism and Terrorism. Acts of vandalism and terrorism are of increasing concern. Louvers and grilles are potential points of illegal access to buildings, so their placement and construction are important. Intentional introduction of offensive or potentially harmful gaseous substances is also of concern. Some prudent initial design considerations might be elevating grilles and louvers away from easy pedestrian access and specifying security bars and other devices. Also, unlocked stair tower doors required for roof access during emergency evacuations may limit use of rooftop air intakes in sensitive applications because individuals would have ready access to the louvers. For more information, see ASHRAE's (2003) *Risk Management Guidance for Health, Safety, and Environmental Security under Extraordinary Incidents*.

General Guidance on Intake Placement

Experience provides some general guidelines on air intake placement. As a rule, intakes should never be located in the same architectural screen enclosure as contaminated exhaust outlets, especially low-momentum exhausts (which tend to be trapped in the wind recirculation zone within the screen). For more information, see the section on Influence of Architectural Screens on Exhaust Dilution.

If exhaust is discharged from several locations on a roof, intakes should be sited to minimize contamination. Typically, this means maximizing separation distance. Where all exhausts of concern are emitted from a single, relatively tall stack or tight cluster of stacks, a possible intake location might be close to the base of this tall stack, if this location is not adversely affected by other exhaust locations, or is not influenced by tall adjacent structures creating downwash. However, contaminant leakage from the side of the stack has been observed in positively pressurized areas between the exhaust fans and stack exit (Hitchings 1997; Knutson 1997), so air intakes should not be placed very close to highly toxic or odorous exhaust stacks regardless of stack height.

Intakes near vehicle loading zones should be avoided. Overhead canopies on vehicle docks do not effectively protect air intakes, and vehicle exhaust may spread over large sections of the building surface. Loading zones also may have garbage and solid waste

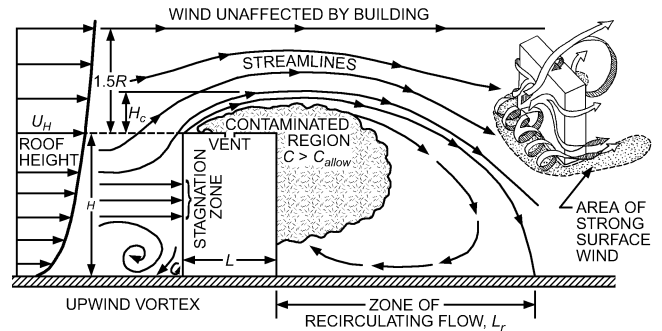

Fig. 4 Flow Patterns Around Rectangular Building

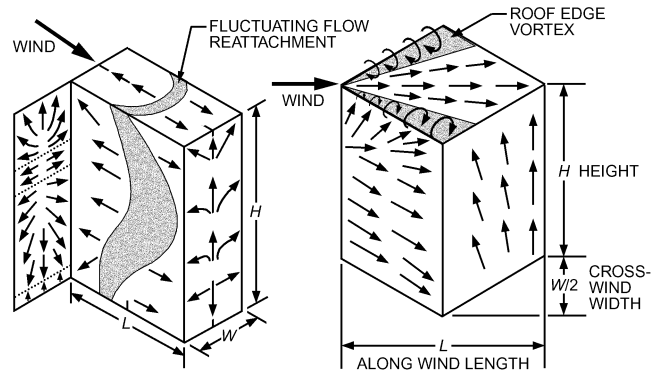

Fig. 5 Surface Flow Patterns and Building Dimensions

receptacles that create odors; trucks that serve the receptacles also produce odors. Air intakes should also not be placed near traffic or truck waiting areas. General building exhausts should also not be placed near outside contamination sources because flow reversal and ingestion of air through exhaust outlets can occur under some conditions (Seem et al. 1998).

Examining airflow around a building can help determine air intake placement. When wind is perpendicular to the upwind wall, air flows up and down the wall, dividing at about two-thirds up the wall (Figures 4 and 5). The downward flow creates ground-level swirl (shown in Figure 4) that stirs up dust and debris. To take advantage of the natural separation of wind over the upper and lower half of a building, toxic or nuisance exhausts should be located on the roof and intakes located on the lower one-third of the building, but high enough to avoid wind-blown dust, debris, and vehicle exhaust. If ground-level sources (e.g., wind-blown dust and vehicle exhaust) are major sources of contamination, rooftop intake is desirable.

Code Requirements for Air Intakes

Many model building codes exist, and local governments adopt and amend codes as needed. Architects and building systems designers need to be familiar with local and national codes applicable to each project. Mechanical and plumbing codes typically give minimum required separation distances for some situations. However, maintaining these separation distances does not necessarily guarantee that intake contamination will not occur.

One example of a model building code is the *Uniform Mechanical Code (UMC)* (IAPMO 1997a), which has been widely adopted in the United States. The UMC requires that exhausts be at least 3 ft from property lines and 3 ft from openings into buildings. Makeup air intakes should be placed to avoid recirculation. Grease and explosives-bearing ducts, combustion vents, and refrigeration equipment have special requirements: intakes should be at least 10 ft from combustion vents, plumbing vents, and exhaust air out-

lets, and be at least 10 ft above a road. Cooling towers should be 5 ft above or 20 ft away from intakes.

The *Uniform Plumbing Code* (UPC) (IAPMO 1997b), requires that exhaust vents from domestic water heaters be 3 ft or more above air inlets. Sanitary vents must be 10 ft or more from or 3 ft above air intakes. When UPC and UMC requirements conflict, the UPC provisions govern. However, local jurisdictions may modify codes, so the adopted versions may have significantly different requirements than the model codes.

Treatment and Control Strategies

When available intake/exhaust separation does not provide the desired dilution factor, or intakes must be placed in undesirable locations, ventilation air requires some degree of treatment, as discussed in Section 6.1.1 of ASHRAE *Standard* 62.1. Fibrous media, inertial collectors, and electrostatic air cleaners, if properly selected, installed, and maintained, can effectively treat airborne particles. Reducing gaseous pollutants requires scrubbing, adsorptive, adsorptive, or incinerating techniques. Biological hazards require special methods such as using high-efficiency particulate air (HEPA) filters and ultraviolet light. Chapters 24 and 25 of the 2004 ASHRAE *Handbook—HVAC Systems and Equipment* describe these treatments in detail. One control approach that should be used with care is selective operation of intakes. If a sensor in the intake airstream detects an unacceptable level of some substance, the outside air dampers are closed until the condition passes. This strategy has been used for helicopter landing pads at hospitals and during emergency generator testing. The drawbacks are that pressurization is lost and ventilation air is not provided unless the recirculated air is heavily treated. In areas of chronically poor outside air quality, such as large urban areas with stagnant air, extensive and typically costly treatment of recirculated air may be the only effective option when outside air dampers are closed for extended periods.

Intake Locations for Heat-Rejection Devices

Cooling towers and similar heat-rejection devices are very sensitive to airflow around buildings. This equipment is frequently roof-mounted, with equipment intakes close to the roof where air can be considerably hotter and at a higher wet-bulb temperature than air that is not affected by the roof. This can reduce the capacity of cooling towers and air-cooled condensers.

Heat exchangers often take in air on one side and discharge heated, moist air horizontally from the other side. Obstructions immediately adjacent to these horizontal-flow cooling towers can drastically reduce equipment performance by reducing airflow. Exhaust-to-intake recirculation can be a serious problem for equipment that has an intake and exhaust on the same housing. Recirculation is even more serious than reduction in airflow rate for these devices. Recirculation of warm, moist exhaust raises the inlet wet-bulb temperature, which reduces performance. Recirculation can be caused by adverse wind direction, local disturbance of the airflow by an upwind obstruction, or by a close downwind obstruction. Vertical exhaust ducts may need to be extended to reduce recirculation and improve equipment effectiveness.

Wind Recirculation Zones on Flat-Roofed Buildings

Stack height design must begin by considering the wind recirculation regions (Figure 6). To avoid exhaust reentry, the stack plume must avoid rooftop air intakes and wind recirculation regions on the roof and in the wake downwind of the building. Where stacks or exhaust vents discharge within this region, gases rapidly diffuse to the roof and may enter ventilation intakes or other openings. Figures 4 and 6 show that exhaust gas from an improperly designed stack is entrained into the recirculating flow zone behind the downwind face and is brought back into contact with the building.

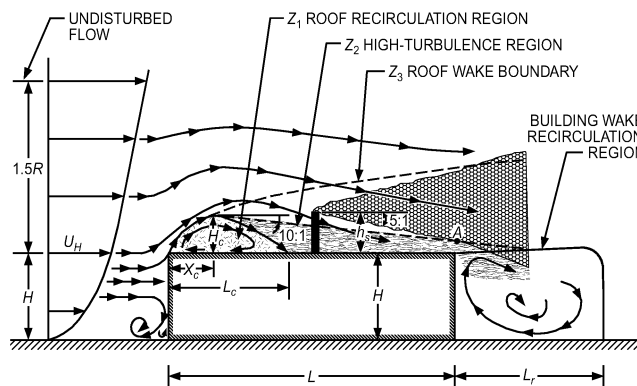

Fig. 6 Design Procedure for Required Stack Height to Avoid Contamination
(Wilson 1979)

Wilson (1979) found that, for a flat-roofed building, the upwind roof edge recirculation region height H_c at location X_c and its recirculation length L_c (shown in Figures 1 and 6) are proportional to the building size scale R :

$$H_c = 0.22R \quad (1)$$

$$X_c = 0.5R \quad (2)$$

$$L_c = 0.9R \quad (3)$$

and the wind recirculation cavity length L_r on the downwind side of the building is approximately

$$L_r = R \quad (4)$$

where R is the building scaling length:

$$R = B_s^{0.67} B_L^{0.33} \quad (5)$$

where B_s is the smaller of the building upwind face dimensions (height or width) and B_L is the larger. These equations are approximate but are recommended for use. The dimensions of flow recirculating zones depend on the amount of turbulence in the approaching wind. High levels of turbulence from upwind obstacles can decrease the coefficients in Equations (1) to (4) by up to a factor of two. Turbulence in the recirculation region and in the approaching wind also causes considerable fluctuation in the position of flow reattachment locations (Figures 5 and 6).

Rooftop obstacles such as penthouses, equipment housings, and architectural screens are accounted for in stack design by calculating the scale length R for each of these rooftop obstacles from Equation (5) using the upwind face dimensions of the obstacle. The recirculation regions for each obstacle are then calculated from Equations (1) to (4). When a rooftop obstacle is close to the upwind edge of a roof or another obstacle, the flow recirculation zones interact. Wilson (1979) gives methods for dealing with these situations.

Building-generated turbulence is confined to the roof wake region, whose upper boundary Z_3 in Figure 6 is

$$Z_3/R = 0.28(x/R)^{0.33} \quad (6)$$

where x is the distance from the upwind roof edge where the recirculation region forms. Building-generated turbulence decreases with increasing height above roof level. At the edge of rooftop wake boundary Z_3 , turbulence intensity is close to the background level in the approach wind. The high levels of turbulence in the air below the

boundary Z_2 in [Figure 6](#) rapidly diffuse exhaust gases downward to contaminate roof-level intakes. As shown in [Figure 6](#), the boundary Z_2 of this high-turbulence region downwind of a wind recirculation region is approximated by a straight line sloping at 10:1 downward from the top of the wind recirculation zone to the roof. The stack in [Figure 6](#) may be inadequate because at point A the plume intersects the high turbulence boundary Z_2 . The geometric method for stack height is discussed in more detail in the next section.

GEOMETRIC METHOD FOR ESTIMATING STACK HEIGHT

This section presents a method of specifying stack height h_s so that the lower edge of the exhaust plume lies above air intakes and wind recirculation zones on the roof and downwind of the emitting building, based on flow visualization studies (Wilson 1979). This method does not calculate exhaust dilution in the plume; instead, it estimates the size of recirculation and high turbulence zones, and the stack height to avoid contamination is calculated from the shape of the exhaust plume. High vertical exhaust velocity is accounted for with a plume rise calculation that shifts the plume upward. Low vertical exhaust velocity that allows stack wake downwash of the plume (see [Figure 3](#)) is accounted for by reducing the effective stack height.

This stack height should prevent reentry of exhaust gas into the emitting building most of the time, provided no large buildings, structures, or terrain are nearby to disturb the approaching wind. The geometric method considers only intakes on the emitting building. Additional stack height or an exhaust-to-intake roof-level dilution calculation is often required if the exhaust plume can impinge on a nearby building (Wilson et al. 1998b). Dilution calculations should be used if this method produces an unsatisfactorily high stack, or if exhaust gases are highly toxic releases from fume hood exhaust.

Rooftop obstacles can significantly alter dispersion from exhaust stacks immediately downwind of the obstacles and of similar height to the obstacles (Saathoff et al. 2002). The goal of the geometric stack method is to ensure that the exhaust plume is well above the recirculation zones associated with these obstacles.

Step 1. Use Equations (1) to (5) to calculate the height and location of flow recirculation zones 1 and 2 and the recirculation zone downwind of the building (see [Figure 6](#)). All zones associated with rooftop obstacles up- and downwind of the stack location should be included. Note that zone 3 is not used in the geometric design method.

Step 2. Draw the recirculation regions on the top and downwind sides of penthouses, equipment housings, architectural screens, and other rooftop obstacles up- and downwind of the stack location. If there are intakes on the downwind wall of the building, include the building recirculation region L_r on this wall. Now, calculate the height h_{sc} of a stack with a rain cap (i.e., no plume rise), draw a line sloping down at 1:5 in the wind direction above the roof. Slide this line down toward the building as shown in [Figure 1](#) until it contacts any one of the recirculation zones on any obstacle up- or downwind of the stack (or until the line contacts any portion of the building if there are no rooftop zones or sidewall intakes). With the line in this position, its height at the stack location is the smallest allowable plume height h_{sc} for that wind direction. Repeat for other wind directions to find the worst-case (highest) required plume height.

This estimated h_{sc} is based on an assumption that the plume spreads up and down from h_{sc} with a 1:5 slope (11.3°), as shown in [Figure 6](#). (This slope represents a downward spread of approximately two standard deviations of a bell-curve Gaussian plume concentration distribution in the vertical direction.)

Step 3. Reduce the stack height to give credit for plume rise from uncapped stacks. Only jet momentum rise is used; buoyancy rise is considered as a safety factor. For an uncapped stack of diameter d_e , plume rise h_r from the vertical jet momentum of the exhaust is estimated from Briggs (1984) as

$$h_r = 3.0\beta d_e(V_e/U_H) \quad (7)$$

where

$$d_e = \sqrt{4A_e/\pi} \quad (8)$$

For an uncapped stack, the capping factor is $\beta = 1.0$. For a capped stack, $\beta = 0$, so $h_r = 0$, and no credit is given for plume rise. U_H is the maximum design wind speed at roof height for which air intake contamination must be avoided. This maximum design speed must be at least as large as the hourly wind speed exceeded 1% of the time. This 1% design speed is listed for many cities in Chapter 28 of the 2005 *ASHRAE Handbook—Fundamentals*. For cities not on this list, set U_H equal to 2.5 times the annual average hourly wind speed as recommended in Table 2 of Chapter 16 of the 2005 *ASHRAE Handbook—Fundamentals*.

The plume rise of Equation (7) is a final plume height that occurs some distance downwind. In reality, the plume gradually rises until reaching this height. Accounting for gradual plume rise is beyond the scope of this chapter. The plume rise of Equation (7) plus the physical stack height should not be considered equivalent to an effective stack height. A real stack of that height has better performance for two reasons: the effective height is achieved immediately instead of somewhere downstream, and the plume is higher than the effective height because of exhaust momentum. Stack height plus plume rise are additive in the geometric method as a simplification, but there are other conservatism built into the geometric method to offset this approach.

Step 4. Increase stack height, if necessary, to account for stack wake downwash caused by low exhaust velocity, as described in the section on Recommended Stack Exhaust Velocity. For a vertically directed jet from an uncapped stack ($\beta = 1.0$), Wilson et al. (1998b) recommend a stack wake downwash adjustment h_d of

$$h_d = d_e(3.0 - \beta V_e/U_H) \quad (9)$$

for $V_e/U_H < 3.0$. For $V_e/U_H > 3.0$, there is no downwash and $h_d = 0$. Rain caps and louvers are frequently used on stacks of gas- and oil-fired furnaces and packaged ventilation units, for which $\beta = 0$ and $h_d = 3.0d_e$.

The final adjusted stack height h_s recommended is

$$h_s = h_{sc} - h_r + h_d \quad (10)$$

The advantage of using an uncapped stack instead of a capped stack is considerable. If the minimum recommended exhaust velocity V_e of $1.5U_H$ is maintained for an uncapped stack ($\beta = 1.0$), plume downwash $h_d = 1.5d_e$ and $h_r = 4.5d_e$. For a capped stack ($\beta = 0$), $h_d = 3.0d_e$ and $h_r = 0$. Using these values in Equation (10), an uncapped stack can be made $6.0d_e$ shorter than a capped stack.

Example 1. The stack height h_s of the uncapped vertical exhaust on the building in [Figure 1](#) must be specified to avoid excessive contamination of intakes A and B by stack gases. The stack has a diameter d_e of 1.64 ft and an exhaust velocity V_e of 1770 fpm. It is located 52.5 ft from the upwind edge of the roof. The penthouse's upwind wall (with intake A) is located 98.4 ft from the upwind edge of the roof, 13.1 ft high, and 23.0 ft long in the wind direction. The top of intake A is 6.56 ft below the penthouse roof. The building has a height H of 49.2 ft and a length of 203 ft. The top of intake B is 19.7 ft below roof level. The width (measured into the page) of the building is 164 ft, and the penthouse is 29.5 ft wide. The annual average hourly wind speed is 7.95 mph at a nearby airport with an anemometer height H_{met} of 32.8 ft. The building is in suburban terrain (Category 2 in Table 1 of Chapter 16 of the 2005 *ASHRAE Handbook—Fundamentals*). Calculate the required stack height h_s by the geometrical method using the lowest allowable design wind speed.

Solution: The first step is to set the height h_{sc} of a capped stack by projecting lines with 1:5 slopes so that recirculation zones are covered, as shown in [Figure 1](#). The only influence of intake location is that the

downwind recirculation zone must be considered if there is an intake on the downwind wall, which is true for intake B in this example.

First, check the rooftop recirculation zone associated with the penthouse. To find the height of this recirculation zone, use Equation (5):

$$R = (13.1)^{0.67} (29.5)^{0.33} = 17.1 \text{ ft}$$

Then use Equations (1) and (2):

$$H_c = (0.22)(17.1) = 3.76 \text{ ft}$$

$$X_c = (0.5)(17.1) = 8.55 \text{ ft}$$

With the 1:5 slope of the lower plume boundary shown in Figure 6, the capped stack height in Figure 1 (measured from the main roof) must be

$$h_{sc} = 0.2(98.4 - 52.5 + 8.55) + 3.76 + 13.1 = 27.8 \text{ ft}$$

to avoid the recirculation zone above the penthouse.

Next, check the building wake recirculation zone downwind of the building. The plume must also avoid this region because intake B is located there. The length of this recirculation region is found using Equation (4):

$$L_r = (49.2)^{0.67} (164)^{0.33} = 73.2 \text{ ft}$$

Projecting the downwind corner of this recirculation region upwind with a 1:5 slope to the stack location gives the required height of a no-downwash capped stack above the main roof level as

$$h_{sc} = 0.2(203 + 73.2 - 52.5) = 44.7 \text{ ft}$$

for the plume to avoid the recirculation zone on the downwind side of the building.

The design stack height is set by the condition of avoiding contamination of the building wake, because avoiding the penthouse roof recirculation requires only a 27.8 ft capped stack. Credit for plume rise h_r from the uncapped stack requires calculation of the building wind speed U_H at $H = 49.2$ ft. The minimum allowable design wind speed is the speed that is exceeded 1% of the time at the meteorological station. From Table 2 in Chapter 16 of the 2005 ASHRAE Handbook—Fundamentals, this is found by multiplying the hourly average wind speed by a factor of 2.5. In this case, for $H_{met} = 32.8$ ft at the airport meteorological station, this 1% wind speed is $U_{met} = 2.5(7.95) = 19.9$ mph = 1751 fpm. With the airport in open terrain (Category 3 of Table 1 of Chapter 16 of the 2005 ASHRAE Handbook—Fundamentals), and the building in urban terrain (Category 2), the wind speed adjustment parameters are $a_{met} = 0.14$ and $\delta_{met} = 900$ ft at the airport, and $a = 0.22$ and $\delta = 1200$ ft at the building. Using Equation (4) in Chapter 16 of the 2005 ASHRAE Handbook—Fundamentals, with building height $H = 49.2$ ft,

$$U_H = 1751 \left(\frac{900}{32.8} \right)^{0.14} \left(\frac{49.2}{1200} \right)^{0.22} = 1379 \text{ fpm}$$

Because $V_e/U_H = 1770/1379 = 1.28$ is less than 3.0, there is some plume downwash as shown in Figure 3. From Equation (9),

$$h_d = 1.64[3 - 1.0(1.28)] = 2.8 \text{ ft}$$

Then, using Equation (7), the plume rise at design wind speed is

$$h_r = 3.0(1.64)(1.28) = 6.3 \text{ ft}$$

Using these values in Equation (10), the uncapped height h_{sc} is, with the height reduction credit for the 6.3 ft rise and the height addition to account for the 2.8 ft downwash,

$$h_s = 44.7 - 6.3 + 2.8 = 41.2 \text{ ft}$$

As shown in Figure 1, this stack height is measured above the main roof. If stack height is higher than desirable, an alternative is to use dilution calculations. The geometric method does not directly account for dilution within the plume.

EXHAUST-TO-INTAKE DILUTION CALCULATIONS

Worst-Case Critical Dilution

This section describes a method for computing outside dilution of exhausts emitted from a rooftop stack. The resulting dilution can

be converted to contaminant concentration for comparison to odor thresholds or health limits. The results and equations given were obtained from wind tunnel studies of simple building shapes.

Dispersion of pollutants from building exhaust depends on the combined effect of atmospheric turbulence in the wind approaching the building and turbulence generated by the building itself. This building-generated turbulence is most intense in and near the flow recirculation zones that occur on the upwind edges of the building (Figures 1 and 5). Dilution of exhaust gas is estimated using design procedures developed for tall isolated stacks (EPA 1995), with modifications to include the high turbulence levels experienced by a plume diffusing over a building roof in an urban area. Halitsky (1982), Hosker (1984), Meroney (1982), and Wilson and Britter (1982) review gas diffusion near buildings.

The geometric stack design procedure does not give a quantitative estimate of the worst-case critical dilution factor D_{crit} at an air intake. If a required dilution can be specified with known stack emissions and required health limits, odor thresholds, or air quality regulations, computing critical dilutions can be an alternative for specifying stack heights. Petersen and Ratcliff (1991) and Smeaton et al. (1991) discuss use of emission information and formulation of dilution requirements in more detail. Exhaust from a single-source dedicated stack may require more atmospheric dilution than a single stack with the same exhausts combined because emissions are diluted in the exhaust manifold.

Dilution and Concentration Definitions

A building exhaust system releases a mixture of building air and pollutant gas at concentration C_e (mass of pollutant per volume of air) into the atmosphere through a stack or vent on the building. The exhaust mixes with atmospheric air to produce a pollutant concentration C , which may contaminate an air intake or receptor if the concentration is larger than some specified allowable value C_{allow} (see Figure 4). The dilution factor D between source and receptor mass concentrations is defined as

$$D = C_e/C \quad (11)$$

where

$$C_e = \text{contaminant mass concentration in exhaust, lb/ft}^3$$

$$C = \text{contaminant mass concentration at receptor, lb/ft}^3$$

The dilution increases with distance from the source, starting from its initial value of unity. If C is replaced by C_{allow} in Equation (11), the atmospheric dilution D_{req} required to meet the allowable concentration at the intake (receptor) is

$$D_{req} = C_e/C_{allow} \quad (12)$$

The exhaust (source) concentration is given by

$$C_e = \dot{m}/Q_e = \dot{m}/(A_e V_e) \quad (13)$$

where

$$\dot{m} = \text{contaminant mass release rate, lb/s}$$

$$Q_e = A_e V_e = \text{total exhaust volumetric flow rate, ft}^3/\text{s}$$

$$A_e = \text{exhaust face area, ft}^2$$

$$V_e = \text{exhaust face velocity, ft/s}$$

The concentration units of mass per mixture volume are appropriate for gaseous pollutants, aerosols, dusts, and vapors. The concentration of gaseous pollutants is usually stated as a volume fraction f (contaminant volume/mixture volume), or as ppm (parts per million) if the volume fraction is multiplied by 10^6 . The pollutant volume fraction f_e in the exhaust is

$$f_e = Q/Q_e \quad (14)$$

where Q is the volumetric release rate of the contaminant gas. Both Q and Q_e are calculated at exhaust temperature T_e .

The volume concentration dilution factor D_v is

$$D_v = f_e / f \quad (15)$$

where f is the contaminant volume fraction at the receptor. If the exhaust gas mixture has a relative molecular mass close to that of air, D_v may be calculated from the mass concentration dilution D by

$$D_v = (T_e / T_a) D \quad (16)$$

where

T_e = exhaust air absolute temperature, °R

T_a = outside ambient air absolute temperature, °R

Many building exhausts are close enough to ambient temperature that volume fraction and mass concentration dilutions D_v and D are equal.

Gaussian Plume Equations for Roof-Level Dilution

This section presents equations for predicting worst-case roof-level dilution of exhaust from a vertical stack on a roof. The equations assume a bell-shaped Gaussian concentration profile in both the vertical and cross-wind horizontal directions. Gaussian profiles have been used in many atmospheric dispersion models, such as those used by the U.S. Environmental Protection Agency. Considering their simplicity, bell-shaped Gaussian concentration profiles in the cross-wind y and vertical z directions at a given horizontal distance x represent atmospheric dispersion remarkably well (Brown et al. 1993).

The dilution equations predict the roof-level dilution D_r , which is the ratio of contaminant concentration C_e at the exit point of the exhaust to the maximum concentration C_r on the plume centerline at roof level, giving $D_r = C_e / C_r$. The centerline of the plume is defined in the x direction, with y the lateral (cross-wind) distance off the plume centerline (axis), and z the vertical. Dilution is affected by three processes:

- Wind carries the plume downwind. The higher the wind speed, the greater the dilution on the plume axis. Wind speed U_H carrying the plume is the wind speed in the undisturbed flow approaching the top of the building.
- Wind turbulence spreads the plume vertically and laterally (cross-wind). Plume spreads in the cross-wind y direction and the vertical z direction are σ_y and σ_z . These plume spreads increase with downwind distance.
- The plume is carried vertically by the initial buoyancy and vertical momentum of the exhaust at the stack exit. The higher the plume, the greater the dilution at the roof surface. The stronger the wind, the less the plume rises, which may produce less dilution.

Thus, wind speed has two influences: (1) at very low wind speed, the exhaust jet from an uncapped stack rises high above roof level, producing a large exhaust dilution D_r at a given intake location; and (2) at high wind speed, the dilution is also large because of longitudinal stretching of the plume by the wind. Between these extremes is the critical wind speed $U_{H,crit}$, at which the smallest amount of dilution occurs for a given exhaust and intake location.

Before performing Gaussian dilution calculations on a rooftop, the effect of rooftop obstacles, wind recirculation zones, and intake location(s) must be considered. Dilution depends on the vertical separation ζ between the plume centerline h_{plume} and h_{top} , defined as the highest of the intake, all active obstacles (discussed later), and recirculation zones defined in Equation (1). Vertical separation ζ is defined as

$$\begin{aligned} \zeta &= h_{plume} - h_{top} \\ &= 0 \text{ if } h_{plume} < h_{top} \end{aligned} \quad (17)$$

Plume centerline h_{plume} is defined as

$$h_{plume} = h_s + h_r - h_d \quad (18)$$

where h_s is the physical stack height above the roof, h_r is the plume rise defined in Equation (7), and h_d is the stack wake downwash defined in Equation (9) (see Figure 1). Close to the stack, the value of ζ must be limited to avoid overprediction of the dilution, as discussed in the section on Limiting Contribution of Plume Rise to D_r Near Stacks.

To determine which rooftop obstacles are considered active in defining h_{top} , start by drawing a line in plan view through the stack location and the intake of interest. All obstacles along this line or one obstacle width laterally (y -direction) from the line are considered active. Obstacles and recirculation zones upstream of the stack and downstream of the intake should also be considered. The value of h_{top} is the higher of the active obstacles, recirculation zones (including zones on top of active obstacles) defined in Equation (1), and the height of the intakes. All of these heights should be referenced to the same roof level used to determine h_s . Once h_{top} is defined and ζ is calculated, dilution at the intake is calculated from

$$D_r = 4 \frac{U_H}{V_e} \times \frac{\sigma_y}{d_e} \times \frac{\sigma_z}{d_e} \exp\left(-\frac{\zeta^2}{2\sigma_z^2}\right) \quad (19)$$

When plume height is less than the height of intakes, active obstacles, and recirculation zones (i.e., $h_{plume} < h_{top}$), then $\zeta = 0$ and dilution should be calculated using Equation (23).

If exhaust gases are hot, buoyancy increases the rise of the exhaust gas mixture and produces lower concentrations (higher dilutions) at roof level. For all exhausts except very hot flue gases from combustion appliances, it is recommended that plume rise from buoyancy be neglected in dilution calculations and stack design on buildings. By neglecting buoyant plume rise, the predicted dilution has an inherent safety factor, particularly at low wind speed, where buoyancy rise is significant.

Limiting Contribution of Plume Rise to D_r Near Stacks

Close to the stack, the ratio $\zeta^2/2\sigma_z^2$ in Equation (19) becomes very large, causing the exponential term to overpredict roof-level dilution D_r . Preventing this requires that $\zeta^2/2\sigma_z^2$ not be allowed to exceed 7.0. Maintaining $\zeta^2/2\sigma_z^2 < 7.0$ limits the amount of dilution allowed by plume rise to $\exp(7.0) = 1100$ near the stack. Limiting $\zeta^2/2\sigma_z^2$ to 7.0 means $\zeta = 3.74\sigma_z$. In effect, this limits Equation (19) to an effective plume height no more than 3.74 vertical plume standard deviations σ_z above the $h_s = 0$ plane.

Cross-Wind and Vertical Plume Spreads for Dilution Calculations

Equations for vertical and cross-wind spread were developed for nonbuoyant exhaust jets from rooftop stacks on flat-roofed buildings (Wilson et al. 1998a). In the first 1000 ft downwind from the stack, both cross-wind plume spread σ_y and vertical plume spread σ_z increase almost linearly with distance X . The recommended equations for plume spreads are based on full-scale atmospheric measurements by McElroy and Pooler (1968) in an urban area, as used in the EPA (1995) model ISCST. The urban ISCST equations are adjusted here from the 60 min measured averaging time to 2 min averages with the 0.2 power law applied to both vertical and cross-wind spreads. Then, the vertical spread over a building roof is assumed to remain constant at the 2 min averaging time value for longer averaging times. The plume equations are as follows:

$$\frac{\sigma_y}{d_e} = 0.071 \left(\frac{t_{avg}}{2.0} \right)^{0.2} \frac{X}{d_e} + \frac{\sigma_o}{d_e} \quad (20)$$

$$\frac{\sigma_z}{d_e} = 0.071 \frac{X}{d_e} + \frac{\sigma_o}{d_e} \quad (21)$$

where t_{avg} is the concentration averaging time in minutes, X is the distance downwind from the stack, and σ_o is the initial source size that accounts for stack diameter and for dilution jet entrainment during plume rise.

The dependence of initial spread σ_o on exit velocity to wind speed ratio V_e/U_H is

$$\frac{\sigma_o}{d_e} = \left[0.125\beta \frac{V_e}{U_H} + 0.911\beta \left(\frac{V_e}{U_H} \right)^2 + 0.250 \right]^{0.5} \quad (22)$$

where β is the rain cap factor: $\beta = 1$ for no rain cap, and $\beta = 0$ if there is a rain cap. For $\beta = 0$, there is still an effective source size σ_o equal to half the diameter d_e of the stack.

The averaging time over which exhaust gas concentration exposures are measured is important in determining roof-level dilution. As averaging time increases, the exhaust gas plume meanders more from side to side, reducing the time-averaged concentration (and increasing the dilution) observed at an air intake location. The effect of changing the averaging time over a range of about 2 to 180 min can be estimated by adjusting the 2 min value of the cross-wind spread σ_y by the 0.2 power of the averaging time t_{avg} (Wollenweber and Panofsky 1989). This averaging time adjustment appears directly in Equation (20). If the exhaust and intake are both located in the same flow recirculation region, dilution is less sensitive to averaging time than predicted by the 0.2 power law. For the case of both stack tip and air intake in the same wind recirculation zone, assume the D_r values for 2 min averages also apply for all averaging times from 2 to 60 min.

Equations (17), (18), (19), and (20) imply that dilution does not depend on the location of either the exhaust or intake, only on the horizontal distance X between them and the vertical separation ζ . This is reasonable when both exhaust and intake locations are on the same building wall or on the roof. Dilution can increase if the intake is below roof level on the sidewall of a building and the exhaust stack is located on the roof; however, at present there are no reliable estimates for this effect on stack exhaust.

Stack Design Using Dilution Calculations and Charts for Critical Wind Speed

Starting with the volume flow rate Q_e and exit diameter d_e of an exhaust stack, dilution calculations can be used to select the design stack height h_s required to produce a specified minimum exhaust-to-intake criteria dilution D at horizontal distance X from the stack. First, the exhaust velocity at the stack tip is calculated from $Q_e = \pi V_e d_e^2/4$. Next, an initial stack height h_s above the roof is selected. Determining final stack height is a trial-and-error procedure in which a first guess is made for the stack height and dilution is calculated for several wind speeds to determine the worst-case critical wind speed $U_{H,crit}$ at which the minimum dilution D_{crit} occurs. Starting with a high U_H (e.g., the speed exceeded less than 1% of the time), a spreadsheet is used to calculate the plume rise h_p from Equation (7), downwash h_d from Equation (9), and plume spreads σ_o , σ_y , and σ_z from Equations (20), (21), and (22). Using the first guess for stack height h_s , Equation (18) is used to calculate plume height h_{plume} . Next, h_{top} is determined and Equation (17) used to calculate the vertical separation ζ . If $\zeta > 0$, Equation (19) is used to calculate the roof-level dilution at the air intake; otherwise, Equation (23) is used. Note that when $\zeta^2/2\sigma_z^2$ is calculated, it must be limited to a maximum of 7.0 in Equation (19). D_r is then recalculated for a range of U_H to determine the critical wind speed at which minimum dilution D_{crit} occurs. If D_{crit} is too high or too low, h_s is

adjusted and the dilution calculations repeated to find a new critical wind speed and dilution.

The charts for four different heights of uncapped stacks (Figure 7) can be used to speed up calculation of h_s . To use the charts, h_s should be referenced above an actual or fictitious h_{top} (i.e., when final h_s is determined from the charts, it is added to h_{top} to determine the final stack height above the roof). Once an initial h_s is selected, the ratios of stack height to inside diameter (h_s/d_e) and of the exhaust-to-intake distance to stack height (X/h_s) are calculated. The two charts with h_s/d_e ratios higher and lower than this first guess are used to read up to the lowest V_e/U_H curve at that X/h_s to find the minimum dilution D_{crit} and critical exhaust velocity ratio $V_e/U_{H,crit}$. Linear interpolation using h_s/d_e between values from the two charts is used to find the D_{crit} and $V_e/U_{H,crit}$ for the first-guess stack height. If this critical dilution is too low or too high, the stack height is adjusted for the second guess and the procedure is repeated until the desired stack height is found.

Figure 8 is a design chart for dilution from capped stacks ($\beta = 0$) with no plume rise. For capped stacks, the critical wind speed for minimum dilution at an intake is related to increased plume spread observed at low wind speeds rather than the competing effects of plume rise versus wind dilution. After making a first guess for stack height, the minimum critical dilution for capped stacks can be calculated directly using the a value $U_{H,crit} = 400$ fpm. This is based on the observation that, for wind speeds less than 400 fpm at roof height, the atmosphere tends to develop high levels of turbulence that cause plume meandering and increase exhaust-to-intake dilution.

Example 2. Using the same building geometry as in Example 1, calculate the dilution for a shorter stack with $h_s = 27.9$ ft above the main roof. The stack has a diameter d_e of 1.64 ft and an exhaust velocity V_e of 1770 fpm. The stack gas concentration must be diluted by 1800:1 to be considered safe for 2 min exposures at intakes A and B. (This required dilution is determined from occupational health standards and estimated emission rates.) Using the dilution charts, calculate the critical roof-level dilution factor D_{crit} and critical wind speed $U_{H,crit}$ for contamination for intakes A and B. Is the stack height of 27.9 ft sufficient to handle this toxic substance?

Solution:

Intake A. In this example, intake A is some height above the main rooftop on the side of the penthouse. There are no recirculation zones or obstructions between the stack and the intake. The penthouse is 13.1 ft above the roof and downwind of the stack, and the peak of the building recirculation zone is upwind of the stack. Thus, $h_{top} = 13.1$ ft. For intake A with this configuration, it is recommended to use the portion of h_s above h_{top} when using the charts: $27.9 - 13.1 = 14.8$ ft. The horizontal distance from the stack to the intake is $X = 45.9$ ft. The stack height ratio is $h_s/d_e = 14.8/1.64 = 9.0$, and the exhaust-to-intake distance ratio $X/h_s = 45.9/14.8 = 3.10$. Then, using Figure 7C for $h_s/d_e = 10$, the critical minimum dilution is 3000, at a critical exhaust velocity to wind speed ratio of about 0.5. Repeating this using Figure 7B for $h_s/d_e = 5$ yields a critical dilution of 250 and a critical exhaust velocity to wind speed ratio of 0.5. Then, interpolating linearly on the height ratio h_s/d_e ,

$$D_{crit} = 3000 - \frac{(10 - 9.0)}{(10 - 5)}(3000 - 250) = 2450$$

Because D_{crit} occurred at $V_e/U_H = 0.5$ on both charts, no interpolation is required and $V_e/U_{H,crit} = 0.5$.

From this velocity ratio, the critical wind speed at roof height is $U_{H,crit} = 1770/0.5 = 2240$ fpm (25.4 mph) for intake A. This high wind speed is likely to occur very rarely. (In Example 1, the hourly average wind speed $U_H = 1379$ fpm or 15.7 mph is exceeded only 1% of the time.) With a predicted dilution of 2450:1, the dilution target of 1800:1 is met at intake A.

Intake B. For intake B, the penthouse for intake A now lies downwind of the stack and upwind of the intake. From Example 1, the recirculation zone on top of the penthouse is 3.8 ft tall. For this example, h_{top} is equal to the height of this penthouse recirculation zone above the roof: $h_{top} = 13.1 + 3.8 = 16.9$ ft. Thus, to use the charts, the height h_s

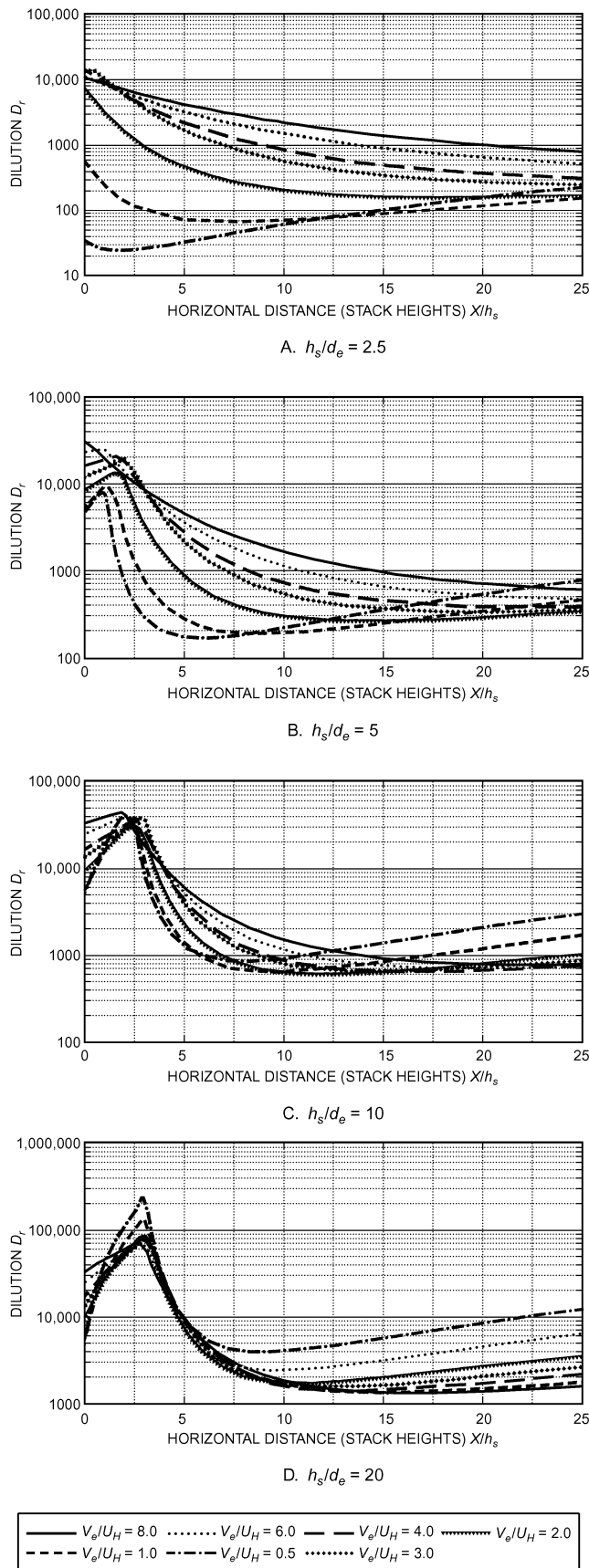

Fig. 7 Dilution Versus Distance for Uncapped Stacks

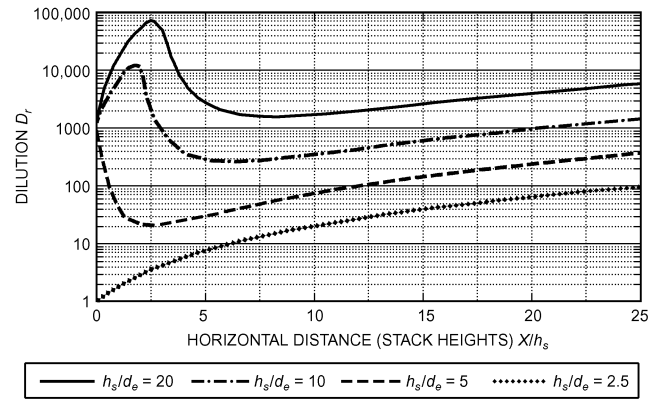

Fig. 8 Dilution Versus Distance for Capped Stack

above h_{top} must be used: $h_s = 27.9 - 16.9 = 11$ ft. The horizontal distance from stack to intake is $X = 150.3$ ft. Then, the stack height ratio is $h_s/d_e = 11/1.64 = 6.7$, and the exhaust-to-intake distance ratio $X/h_s = 150.3/11 = 13.7$. Then, using Figure 7C for $h_s/d_e = 10$, the critical minimum dilution is 600, at a critical exhaust velocity to wind speed ratio of about 2.0. Repeating this using Figure 7B for $h_s/d_e = 5$ yields a critical dilution of 230 and a critical exhaust velocity to wind speed ratio of 1.0. Then, interpolating linearly on the height ratio h_s/d_e ,

$$D_{crit} = 600 - \frac{(10 - 6.7)}{(10 - 5)} (600 - 230) = 356$$

$$\frac{V_e}{U_{H,crit}} = 2 - \frac{(10 - 6.7)}{(10 - 5)} (2 - 1.0) = 1.3$$

From this velocity ratio the critical wind speed at roof height is $U_{H,crit} = 1770/1.3 = 1362$ fpm (15.5 mph) for intake B. As with intake A, this speed occurs less than 1% of the time.

In summary, intake A with a critical dilution of 2450 met the health and safety requirement of providing a minimum exhaust-to-intake dilution of at least 1800, whereas intake B with a dilution of 356:1 did not.

Dilution from Flush Exhaust Vents with No Stack

For exhaust grilles and louvers on the roof or walls of a building or penthouse, vertical separation $\zeta = 0$ in Equation (19). Combining Equations (19), (20), and (21) gives

$$D_s = 4 \frac{U_H}{V_e} \left[0.071 \left(\frac{t_{avg}}{2.0} \right)^{0.2} \frac{S}{d_e} + \frac{\sigma_o}{d_e} \right] \left(0.071 \frac{S}{d_e} + \frac{\sigma_o}{d_e} \right) \quad (23)$$

where the stretched-string distance S between the nearest edge of the exhaust to the nearest edge of the intake replaces horizontal distance X in the cross-wind and vertical plume spreads σ_y and σ_z in Equations (20) and (21). The concentration averaging time t_{avg} at the intake is in minutes, for the reference averaging time of 2.0 min. The subscript s in the dilution D_s from a surface exhaust distinguishes it from the roof-level dilution D_r from a stack [Equation (19)]. The initial dilution in the flush-vent exhaust plume can be approximated by an uncapped jet with $\beta = 1.0$ in Equation (22) to calculate the effective source spread σ_o that generates the self-dilution by jet entrainment.

Minimum critical dilutions for flush exhausts can be calculated using the approximate value $U_{H,crit} = 400$ fpm based on the observation that, for wind speeds less than 400 fpm at roof height, the atmosphere tends to develop high levels of turbulence that increase exhaust-to-intake dilution. For flush roof exhausts with no stack, and for wall intakes, the experiments of Li and Meroney (1983) suggest that D_s at the intake is about a factor of 4 larger than the dilution at a roof-level intake the same stretched-string distance S from the stack.

Example 3. The exhaust flow of $Q_e = 3740$ cfm in Example 1 comes from a louvered grille at location A. The exhaust grille is 2.3 ft high and 2.3 ft wide. What is the critical exhaust-to-intake dilution factor at intake B on the downwind wall of the building for averaging times of 2 min and 60 min?

Solution: Exhaust grille A has a face area of $A_e = 5.29$ ft² and an exhaust velocity V_e of 707 fpm. From Equation (8), the effective exhaust diameter is $d_e = [(4)(5.29)/\pi]^{0.5} = 2.60$ ft. The stretched-string distance S from exhaust A to intake B is the sum of the 6.56 ft from the top of A to the top of the penthouse, plus the 23 ft length of the penthouse, plus the sloped line of horizontal length 81.6 ft from the downwind edge of the penthouse roof, and a vertical drop of 13.1 ft to the roof, plus the 19.7 ft to intake B:

$$S = 6.56 + 23.0 + \sqrt{81.6^2 + (13.1 + 19.7)^2} = 117.5 \text{ ft}$$

so that $S/d_e = 117.5/2.60 = 45.2$ ft. The critical wind speed is approximately $U_{H,crit} = 400$ fpm for capped stacks and flush vents. The initial plume spread σ_o is calculated from Equation (22) with $V_e/U_H = 707/400 = 1.77$ ft, and an uncapped exhaust, $\beta = 1.0$,

$$\frac{\sigma_o}{d_e} = \sqrt{0.125(1.0)(1.77) + 0.911(1.0)(1.77)^2 + 0.250} = 1.82$$

The critical dilution of exhaust from A at intake B is calculated from Equation (23):

$$D_{s,crit} = 4 \left(\frac{400}{707} \right) \left[0.071 \left(\frac{t_{avg}}{2.0} \right)^{0.2} (45.2) + 1.82 \right] \left[0.071(45.2) + (1.82) \right]$$

For an averaging time $t_{avg} = 2$ min, the critical dilution is 57, and 93 for a 60 min averaging time. Because the plume from A passes around the edge of the roof to reach intake B, dilution can be increased by a factor of 4 (Li and Meroney 1983) to obtain $D_{s,crit} = 57(4) = 228$ for 2 min and $D_{s,crit} = 93(4) = 372$ for 60 min. These are conservative estimates because they represent the dilution at a low critical wind speed of 400 fpm, which is 4.5 mph. Using the method in Example 1, the annual average hourly wind speed at roof height is 6.3 mph.

Annual Hours of Occurrence of Highest Intake Contamination

To assess the severity of the hazard caused by intake contamination, it is useful to know the number of hours per year that exhaust-to-intake dilution is likely to be no more than a factor of two higher than the worst-case minimum dilution D_{crit} calculated at $U_{H,crit}$. The first step in making a frequency-of-occurrence estimate for the number of low-dilution hours is to use the dilution charts in Figures 2 and 8 to find the range of wind speeds U_H over which the dilution D_r is within a factor of two of D_{crit} . The upper and lower limits of this range are then converted to the upper and lower limits of the meteorological station wind speed U_{met} . Weather data are then used to calculate the number of hours per year that wind speeds fall in this range. This number of hours is multiplied by the fraction of time the local wind direction lies in a sector 22.5° on each side of the line joining the exhaust and intake location.

Combined Exhausts and Ganged Stacks

When exhaust from several collecting stations is combined in a single vent or in a tight cluster of stacks (as recommended in the section on Exhaust Stack and Air Intake Design Strategies), the exhaust concentration C_e of each contaminant stream decreases by mixing with other exhaust streams, and the plume rise increases due to the higher mass flow in the combined jet. Combined exhaust streams significantly lower roof-level intake concentration C_r compared to that from separate exhausts. Where possible, exhausts should be combined before release to take advantage of this increase in overall dilution.

Influence of Architectural Screens on Exhaust Dilution

Architectural screens are often placed around rooftop equipment to reduce noise or hide equipment. Unfortunately, these screens interact with windflow patterns on the roof and can adversely affect exhaust dilution and thermal efficiency of equipment inside the screen. This section describes a method to account for these screens by modifying the physical stack height h . Architectural screens generate flow recirculation regions similar to those shown downwind of the building and penthouse in Figure 1. These screens are often made of porous materials with mesh or louvers, which influence the height of the recirculation cavity above the screens.

To incorporate the effect of architectural screens into existing dilution prediction equations, a stack height reduction factor F_h is introduced. Using the equation developed by Petersen et al. (1999), stack height h_s above the roof must be multiplied by F_h when the stack is enclosed within a screen. Effective stack height $h_{s,eff}$ measured above roof level is

$$h_{s,eff} = F_h h_s \quad (24)$$

The stack height reduction factor F_h is directly related to screen porosity P_s . For stack heights above the top of the screen that are less than 2.5 times the height of the screen,

$$F_h = 0.81P_s + 0.20 \quad (25)$$

where porosity is

$$P_s = \frac{\text{Open area}}{\text{Total area}} \quad (26)$$

F_h is applied directly to h_s after the required stack height has been calculated, and should be included where the physical stack height is less than 2.5 times the height of the architectural screen.

Example 4. Calculate the required stack height for an uncapped stack with a height of 15.5 ft above roof level, surrounded by a 10 ft high, 50% porous architectural screen.

Solution: To determine the effect of the 50% porous screen, use Equation (25) with $P_s = 0.5$

$$F_h = 0.81(0.5) + 0.2 = 0.605$$

The screen has reduced the effective stack height from its actual height of 15.5 ft to

$$h_{s,eff} = 0.605(15.5) = 9.38 \text{ ft}$$

When the effect of the 50% porous screen is added, the 15.5 ft stack height is found to behave like a 9.38 ft stack. The actual stack height h_s must be increased to account for the screen's effect. This is most easily done by dividing h_s by the stack height reduction factor:

$$h_{s,corrected} = \frac{h_s}{F_h} = \frac{15.5}{0.605} = 25.6 \text{ ft}$$

The corrected 25.6 ft high stack effectively behaves like a 15.5 ft tall stack, and should produce the same dilution at downwind air intakes.

Scale Model Simulation and Testing

For many routine design applications, exhaust dilution can be estimated using the data and equations presented in this chapter, which are based on scale modeling of simple building shapes. However, in critical applications, such as where health and safety or energy costs are of concern, or for complicated building configurations, physical modeling or full-scale field evaluations may be required to obtain more accurate estimates. Measurements on small-scale models in wind tunnels or water channels can provide the required design information. Scale modeling is discussed in Chapter 16 of the 2005 ASHRAE Handbook—Fundamentals.

SYMBOLS

A_e = stack or exhaust exit face area, ft²
 B_L = larger of two upwind building face dimensions H and W , ft
 B_s = smaller of two upwind building face dimensions H and W , ft
 C = contaminant mass concentration at receptor at ambient air temperature T_e , Equation (11), lb/ft³
 C_{allow} = allowable concentration of contaminant at receptor, Equation (12)
 C_e = contaminant mass concentration in exhaust at exhaust temperature T_e , Equation (11), lb/ft³
 D = dilution factor between source and receptor mass concentrations, Equation (11)
 D_{crit} = critical dilution factor at roof level for uncapped vertical exhaust at critical wind speed $U_{H,crit}$ that produces smallest value of D_r for given exhaust-to-intake distance S and stack height h_s
 \hat{d}_e = effective exhaust stack diameter, Equation (8), ft
 D_r = roof-level dilution factor D at given wind speed for all exhaust locations at same fixed distance S from intake, Equation (19)
 D_{req} = atmospheric dilution required to meet allowable concentration of contaminant C_{allow} , Equation (12)
 D_S = dilution at a wall or roof intake from a flush exhaust grille or louvered exhaust, Equation (23)
 D_v = dilution factor between source and receptor using volume fraction concentrations, Equation (15)
 f = contaminant volume concentration fraction at receptor; ratio of contaminant gas volume to total mixture volume, Equation (15), ppm $\times 10^{-6}$
 f_e = contaminant volume concentration fraction in exhaust gas; ratio of contaminant gas volume to total mixture volume, Equation (14), ppm $\times 10^{-6}$
 F_h = stack height adjustment factor to adjust existing stack height above screen for influence of screen of exhaust gas dilution, Equation (25)
 H_c = maximum height above roof level of upwind roof edge flow recirculation zone, Equation (1), ft
 h_{crit} = height of plume above roof level with plume rise and downwash calculated at the critical wind speed U_{crit} , ft
 h_d = downwash correction to be subtracted from stack height, Equation (9), ft
 H_{met} = anemometer height, ft
 h_{plume} = final plume height, Equation (18), ft
 h_r = plume rise of uncapped vertical exhaust jet, Equation (7), ft
 h_s = physical exhaust stack height (typically above roof unless otherwise specified), ft
 h_{sc} = required height of capped exhaust stack to avoid excessive intake contamination, Equation (10), ft
 $h_{s,eff}$ = effective exhaust stack height above roof on which it is located, corrected for an architectural screen surrounding the stack, Equation (24), ft
 h_{top} = height of highest of intake, active obstacle, or recirculation zone on a rooftop between the stack and intake, Equation (17), ft
 L = length of building in wind direction, Figure 5, ft
 L_c = length of upwind roof edge recirculation zone, Equation (3), ft
 L_r = length of flow recirculation zone behind rooftop obstacle or building, Equation (4), ft
 \dot{m} = contaminant mass release rate, Equation (13), lb/s
 P_s = porosity of an architectural screen near a stack, Equation (26)
 Q = contaminant volumetric release rate, Equation (14), ft³/s
 Q_e = total exhaust volumetric flow rate, Equation (13), ft³/s
 R = scaling length for roof flow patterns, Equation (5), ft
 S = stretched-string distance; shortest distance from exhaust to intake over obstacles and along building surface, Equation (23), ft
 T_a = outdoor ambient air absolute temperature, Equation (16), °R
 t_{avg} = time interval over which receptor (intake) concentrations are averaged in computing dilution, Equation (20), min
 T_e = exhaust air mixture absolute temperature, Equation (16), °R
 U_H = mean wind speed at height H of upwind wall in undisturbed flow approaching building, Equation (7), ft/s
 $U_{H,crit}$ = critical wind speed that produces smallest roof-level dilution factor D_{crit} for uncapped vertical exhaust at given X and h_s , ft/s
 V_e = exhaust gas velocity, Equation (13), ft/s
 W = width of upwind building face, ft

x = horizontal distance from upwind roof edge where recirculation region forms in direction of wind, ft
 X = downwind horizontal distance from center of stack, Equations (20) and (21), ft
 X_c = distance from upwind roof edge to H_c , Equation (2), ft
 y = cross-wind distance off the plume centerline, ft
 z = vertical distance, ft
 Z_1 = height of flow recirculation zone boundary above roof, Figure 6, ft
 Z_2 = height of high turbulence zone boundary above roof, Figure 6, ft
 Z_3 = height of roof edge wake boundary above the roof, Equation (6) and Figure 6, ft

Greek

β = capping factor; 1.0 for vertical uncapped roof exhaust; 0 for capped, louvered, or downward-facing exhaust
 ζ = vertical separation above h_{top} , Equation (17), ft
 σ_o = standard deviation of initial plume spread at the exhaust used to account for initial dilution, Equation (20), ft
 σ_y = standard deviation of cross-wind plume spread, Equation (20), ft
 σ_z = standard deviation of vertical plume spread, Equation (21), ft

REFERENCES

- AIHA. 2003. Laboratory ventilation. ANSI/AIHA *Standard Z9.5-2003*. American Industrial Hygiene Association, Fairfax, VA.
 AMCA. 2003. Application manual for air louvers. AMCA *Publication 501-03*. Air Movement and Control Association, Arlington Heights, IL.
 ASHRAE. 2000. Minimizing the risk of Legionellosis associated with building water systems. ASHRAE *Guideline 12-2000*.
 ASHRAE. 2003. *Risk management guidance for health, safety, and environmental security under extraordinary incidents*.
 ASHRAE. 2004. Ventilation for acceptable indoor air quality. ANSI/ASHRAE *Standard 62.1-2004*.
 Briggs, G.A. 1984. Plume rise and buoyancy effects. In *Atmospheric Science and Power Production*, D. Randerson, ed. U.S. Department of Energy DOE/TIC-27601 (DE 84005177), Washington, D.C.
 Brown, M., S.P. Arya, and W.H. Snyder. 1993. Vertical dispersion from surface and elevated releases: An investigation of a non-Gaussian plume model. *Journal of Applied Meteorology* 32:490-505.
 Changnon, S.A. 1966. Selected rain-wind relations applicable to stack design. *Heating, Piping, and Air Conditioning* 38(3):93.
 EPA. 1995. *User's guide for the Industrial Source Complex (ISC3) dispersion models*, vol. 2: *Description of model algorithms*. EPA-454/B-95-003B. U.S. Environmental Protection Agency, Research Triangle Park, NC.
 Gregoric, M., L.R. Davis, and D.J. Bushnell. 1982. An experimental investigation of merging buoyant jets in a crossflow. *Journal of Heat Transfer, Transactions of ASME* 104:236-240.
 Halitsky, J. 1982. Atmospheric dilution of fume hood exhaust gases. *American Industrial Hygiene Association Journal* 43(3):185-189.
 Hitchings, D.T. 1997. Laboratory fume hood and exhaust fan penthouse exposure risk analysis using the ANSI/ASHRAE *Standard 110-1995* and other tracer gas methods. ASHRAE *Transactions* 103(2).
 Hosker, R.P. 1984. Flow and diffusion near obstacles. In *Atmospheric Science and Power Production*, D. Randerson, ed. U.S. Department of Energy DOE/TIC-27601 (DE 84005177).
 IAPMO. 1997a. *Uniform mechanical code*. International Association of Plumbing and Mechanical Officials, Ontario, California.
 IAPMO. 1997b. *Uniform plumbing code*. International Association of Plumbing and Mechanical Officials, Ontario, California.
 ICC. 2006. *International building code*. International Code Council, Falls Church, VA.
 Knutson, G.W. 1997. Potential exposure to airborne contamination in fan penthouses. ASHRAE *Transactions* 103(2).
 Li, W.W. and R.N. Meroney. 1983. Gas dispersion near a cubical building. *Journal of Wind Engineering and Industrial Aerodynamics* 12:15-33.
 McElroy, J.L. and F. Pooler. 1968. *The St. Louis dispersion study*. U.S. Public Health Service, National Air Pollution Control Administration.
 Meroney, R.N. 1982. Turbulent diffusion near buildings. *Engineering Meteorology* 48:525.
 NFPA. 2004. Fire protection for laboratories using chemicals. ANSI/NFPA *Standard 45-04*. National Fire Protection Association, Quincy, MA.
 NFPA. 2006. Recommended practice for smoke-control systems. NFPA *Standard 92A-2006*. National Fire Protection Association, Quincy, MA.

- Petersen, R.L. and J.W. LeCompte. 2002. Exhaust contamination of hidden versus visible air intakes. *Final Report*, ASHRAE RP-1168.
- Petersen, R.L. and M.A. Ratcliff. 1991. An objective approach to laboratory stack design. *ASHRAE Transactions* 97(2):553-562.
- Petersen, R.L., M.A. Ratcliff, and J.J. Carter. 1999. Influence of architectural screens on rooftop concentrations due to effluent from short stacks. *ASHRAE Transactions* 105(1).
- Puckorius, P.R. 1999. Update on Legionnaires' disease and cooling systems: Case history reviews—What happened/what to do and current guidelines. *ASHRAE Transactions* 105(2).
- Ratcliff, M.A., R.L. Petersen, and B.C. Cochran. 1994. Wind tunnel modeling of diesel motors for fresh air intake design. *ASHRAE Transactions* 100(2):603-611.
- Rock, B.A. and K.A. Moylan. 1999. Placement of ventilation air intakes for improved IAQ. *ASHRAE Transactions* 105(1).
- Saathoff, P., L. Lazure, T. Stathopoulos, and H. Peperkamp. 2002. The influence of a rooftop structure on the dispersion of exhaust from a rooftop stack. Presented at the 2002 ASHRAE Meeting, Honolulu.
- Seem, J.E., J.M. House, and C.J. Klaassen. 1998. Volume matching control: Leave the outside air damper wide open. *ASHRAE Journal* 40(2): 58-60.
- Smeaton, W.H., M.F. Lepage, and G.D. Schuyler. 1991. Using wind tunnel data and other criteria to judge acceptability of exhaust stacks. *ASHRAE Transactions* 97(2):583-588.
- Vanderheyden, M.D. and G.D. Schuyler. 1994. Evaluation and quantification of the impact of cooling tower emissions on indoor air quality. *ASHRAE Transactions* 100(2):612-620.
- Wilson, D.J. 1979. Flow patterns over flat roofed buildings and application to exhaust stack design. *ASHRAE Transactions* 85:284-295.
- Wilson, D.J. 1982. Critical wind speeds for maximum exhaust gas reentry from flush vents at roof level intakes. *ASHRAE Transactions* 88(1):503-513.
- Wilson, D.J. and R.E. Britter. 1982. Estimates of building surface concentrations from nearby point sources. *Atmospheric Environment* 16: 2631-2646.
- Wilson, D.J. and G. Winkel. 1982. The effect of varying exhaust stack height on contaminant concentration at roof level. *ASHRAE Transactions* 88(1):513-533.
- Wilson, D.J., I. Fabris, and M.Y. Ackerman. 1998a. Measuring adjacent building effects on laboratory exhaust stack design. *ASHRAE Transactions* 104(2):1012-1028.
- Wilson, D.J., I. Fabris, J. Chen, and M.Y. Ackerman. 1998b. Adjacent building effects on laboratory fume hood exhaust stack design. *Final Report*, ASHRAE RP-897.
- Wollenweber, G.C. and H.A. Panofsky. 1989. Dependence of velocity variance on sampling time. *Boundary Layer Meteorology* 47:205-215.

BIBLIOGRAPHY

- Chui, E.H. and D.J. Wilson. 1988. Effects of varying wind direction on exhaust gas dilution. *Journal of Wind Engineering and Industrial Aerodynamics* 31:87-104.
- Petersen, R.L., B.C. Cochran, and J.J. Carter. 2002. Specifying exhaust and intake systems. *ASHRAE Journal* 44(8):30-35.

[Related Commercial Resources](#)