

CHAPTER 50

SNOW MELTING AND FREEZE PROTECTION

[HYDRONIC AND ELECTRIC SNOW-MELTING SYSTEMS](#)..... 50.1
[Snow-Melting Heat Flux Requirement](#)..... 50.1
[Slab Design](#) 50.8
[Control](#) 50.10
[Hydronic System Design](#) 50.10
[Electric System Design](#)..... 50.13
[Freeze Protection Systems](#) 50.17

THE practicality of melting snow or ice by supplying heat to the exposed surface has been demonstrated in many installations, including sidewalks, roadways, ramps, bridges, access ramps, and parking spaces for the handicapped, and runways. Melting eliminates the need for snow removal by chemical means, provides greater safety for pedestrians and vehicles, and reduces the labor and cost of slush removal. Other advantages include eliminating piled snow, reducing liability, and reducing health risks of manual and mechanized shoveling.

This chapter covers three types of snow-melting and freeze protection systems:

1. Hot fluid circulated in slab-embedded pipes (**hydronic**)
2. Embedded **electric** heater cables or wire
3. Overhead high-intensity **infrared** radiant heating

Detailed information about slab heating can be found in Chapter 6 of the 2004 *ASHRAE Handbook—HVAC Systems and Equipment*. More information about infrared heating can be found in Chapter 15 of the same volume.

Components of the system design include (1) heat requirement, (2) slab design, (3) control, and (4) hydronic or electric system design.

HYDRONIC AND ELECTRIC SNOW-MELTING SYSTEMS

SNOW-MELTING HEAT FLUX REQUIREMENT

The heat required for snow melting depends on five atmospheric factors: (1) rate of snowfall, (2) snowfall-coincident air dry-bulb temperature, (3) humidity, (4) wind speed near the heated surface, and (5) apparent sky temperature. The dimensions of the snow-melting slab affect heat and mass transfer rates at the surface. Other factors such as back and edge heat losses must be considered in the complete design.

Heat Balance

The processes that establish the heat requirement at the snow-melting surface can be described by terms in the following equation, which is the steady-state energy balance for required total heat flux (heat flow rate per unit surface area) q_o at the upper surface of a snow-melting slab during snowfall.

$$q_o = q_s + q_m + A_r(q_h + q_e) \tag{1}$$

where

- q_o = heat flux required at snow-melting surface, Btu/h·ft²
- q_s = sensible heat flux, Btu/h·ft²

- q_m = latent heat flux, Btu/h·ft²
- A_r = snow-free area ratio, dimensionless
- q_h = convective and radiative heat flux from snow-free surface, Btu/h·ft²
- q_e = heat flux of evaporation, Btu/h·ft²

Sensible and Latent Heat Fluxes. The sensible heat flux q_s is the heat flux required to raise the temperature of snow falling on the slab to the melting temperature plus, after the snow has melted, to raise the temperature of the liquid to the assigned temperature t_f of the liquid film. The snow is assumed to fall at air temperature t_a . The latent heat flux q_m is the heat flux required to melt the snow. Under steady-state conditions, both q_s and q_m are directly proportional to the snowfall rate s .

Snow-Free Area Ratio. Sensible and latent (melting) heat fluxes occur on the entire slab during snowfall. On the other hand, heat and mass transfer at the slab surface depend on whether there is a snow layer on the surface. Any snow accumulation on the slab acts to partially insulate the surface from heat losses and evaporation. The insulating effect of partial snow cover can be large. Because snow may cover a portion of the slab area, it is convenient to think of the insulating effect in terms of an effective or equivalent snow-covered area A_s , which is perfectly insulated and from which no evaporation and heat transfer occurs. The balance is then considered to be the equivalent snow-free area A_f . This area is assumed to be completely covered with a thin liquid film; therefore, both heat and mass transfer occur at the maximum rates for the existing environmental conditions. It is convenient to define a dimensionless **snow-free area ratio** A_r :

$$A_r = \frac{A_f}{A_t} \tag{2}$$

where

- A_f = equivalent snow-free area, ft²
- A_s = equivalent snow-covered area, ft²
- $A_t = A_f + A_s$ = total area, ft²

Therefore,

$$0 \leq A_r \leq 1$$

To satisfy $A_r = 1$, the system must melt snow rapidly enough that no accumulation occurs. For $A_r = 0$, the surface is covered with snow of sufficient thickness to prevent heat and evaporation losses. Practical snow-melting systems operate between these limits. Earlier studies indicate that sufficient snow-melting system design information is obtained by considering three values of the free area ratio: 0, 0.5, and 1.0 (Chapman 1952).

Heat Flux because of Surface Convection, Radiation, and Evaporation. Using the snow-free area ratio, appropriate heat and mass transfer relations can be written for the snow-free fraction of the slab A_r . These appear as the third and fourth terms on the right-hand side of Equation (1). On the snow-free surface, maintained at

The preparation of this chapter is assigned to TC 6.5, Radiant and Convective Space Heating and Cooling.

film temperature t_f , heat is transferred to the surroundings and mass is transferred from the evaporating liquid film. Heat flux q_h includes convective losses to the ambient air at temperature t_a and radiative losses to the surroundings, which are at mean radiant temperature T_{MR} . The convection heat transfer coefficient is a function of wind speed and a characteristic dimension of the snow-melting surface. This heat transfer coefficient is also a function of the thermodynamic properties of the air, which vary slightly over the temperature range for various snowfall events. The mean radiant temperature depends on air temperature, relative humidity, cloudiness, cloud altitude, and whether snow is falling.

The heat flux q_e from surface film evaporation is equal to the evaporation rate multiplied by the heat of vaporization. The evaporation rate is driven by the difference in vapor pressure between the wet surface of the snow-melting slab and the ambient air. The evaporation rate is a function of wind speed, a characteristic dimension of the slab, and the thermodynamic properties of the ambient air.

Heat Flux Equations

Sensible Heat Flux. The sensible heat flux q_s is given by the following equation:

$$q_s = \rho_{water} s [c_{p,ice}(t_s - t_a) + c_{p,water}(t_f - t_s)] / c_1 \quad (3)$$

where

- $c_{p,ice}$ = specific heat of ice, Btu/lb·°F
- $c_{p,water}$ = specific heat of water, Btu/lb·°F
- s = snowfall rate water equivalent, in/h
- t_a = ambient temperature coincident with snowfall, °F
- t_f = liquid film temperature, °F
- t_s = melting temperature, °F
- ρ_{water} = density of water, lb/ft³
- c_1 = 12 in/ft

The density of water, specific heat of ice, and specific heat of water are approximately constant over the temperature range of interest and are evaluated at 32°F. The ambient temperature and snowfall rate are available from weather data. The liquid film temperature is usually taken as 33°F.

Melting Heat Flux. The heat flux q_m required to melt the snow is given by the following equation:

$$q_m = \rho_{water} s h_{if} / c_1 \quad (4)$$

where h_{if} = heat of fusion of snow, Btu/lb.

Convective and Radiative Heat Flux from a Snow-Free Surface. The corresponding heat flux q_h is given by the following equation:

$$q_h = h_c(t_f - t_a) + \sigma \epsilon_s (T_f^4 - T_{MR}^4) \quad (5)$$

where

- h_c = convection heat transfer coefficient for turbulent flow, Btu/h·ft²·°F
- T_f = liquid film temperature, °R
- T_{MR} = mean radiant temperature of surroundings, °R
- σ = Stefan-Boltzmann constant = 0.1712×10^{-8} Btu/h·ft²·°R⁴
- ϵ_s = emittance of surface, dimensionless

The convection heat transfer coefficient over the slab on a plane horizontal surface is given by the following equations (Incropera and DeWitt 1996):

$$h_c = 0.037 \left(\frac{k_{air}}{L} \right) \text{Re}_L^{0.8} \text{Pr}^{1/3} \quad (6)$$

where

- k_{air} = thermal conductivity of air at t_a , Btu·ft/h·ft²·°F

L = characteristic length of slab in direction of wind, ft

Pr = Prandtl number for air, taken as $\text{Pr} = 0.7$

Re_L = Reynolds number based on characteristic length L

and

$$\text{Re}_L = \frac{VL}{\nu_{air}} c_2 \quad (7)$$

where

V = design wind speed near slab surface, mph

ν_{air} = kinematic viscosity of air, ft²/h

c_2 = 5280 ft/mile

Without specific wind data for winter, the extreme wind data in Chapter 28 of the 2005 ASHRAE Handbook—Fundamentals may be used; however, it should be noted that these wind speeds may not correspond to actual measured data. If the snow-melting surface is not horizontal, the convection heat transfer coefficient might be different, but in many applications, this difference is negligible.

From Equations (6) and (7), it can be seen that the turbulent convection heat transfer coefficient is a function of $L^{-0.2}$. Because of this relationship, shorter snow-melting slabs have higher convective heat transfer coefficients than longer slabs. For design, the shortest dimension should be used (e.g., for a long, narrow driveway or sidewalk, use the width). A snow-melting slab length $L = 20$ ft is used in the heat transfer calculations that resulted in Tables 1, 2, and 3.

The **mean radiant temperature** T_{MR} in Equation (5) is the equivalent blackbody temperature of the surroundings of the snow-melting slab. Under snowfall conditions, the entire surroundings are approximately at the ambient air temperature (i.e., $T_{MR} = T_a$). When there is no snow precipitation (e.g., during idling and after snowfall operations for $A_r < 1$), the mean radiant temperature is approximated by the following equation:

$$T_{MR} = [T_{cloud}^4 F_{sc} + T_{sky\ clear}^4 (1 - F_{sc})]^{1/4} \quad (8)$$

where

F_{sc} = fraction of radiation exchange that occurs between slab and clouds

T_{cloud} = temperature of clouds, °R

$T_{sky\ clear}$ = temperature of clear sky, °R

The equivalent blackbody temperature of a clear sky is primarily a function of the ambient air temperature and the water content of the atmosphere. An approximation for the clear sky temperature is given by the following equation, which is a curve fit of data in Ramsey et al. (1982):

$$T_{sky\ clear} = T_a - (1.99036 \times 10^3 - 7.562 T_a + 7.407 \times 10^{-3} T_a^2 - 56.325 \phi + 26.25 \phi^2) \quad (9)$$

where

T_a = ambient temperature, °R

ϕ = relative humidity of air at elevation for which typical weather measurements are made, decimal

The cloud-covered portion of the sky is assumed to be at T_{cloud} . The height of the clouds may be assumed to be 10,000 ft. The temperature of the clouds at 10,000 ft is calculated by subtracting the product of the average lapse rate (rate of decrease of atmospheric temperature with height) and the altitude from the atmospheric temperature T_a . The average lapse rate, determined from the tables of U.S. Standard Atmospheres (COESA 1976), is 3.5°F per 1000 ft of elevation (Ramsey et al. 1982). Therefore, for clouds at 10,000 ft,

$$T_{cloud} = T_a - 35 \quad (10)$$

Under most conditions, this method of approximating the temperature of the clouds provides an acceptable estimate. However, when the atmosphere contains a very high water content, the temperature calculated for a clear sky using Equation (9) may be warmer than the cloud temperature estimated using Equation (10). When that condition exists, T_{cloud} is set equal to the calculated clear sky temperature $T_{sky\ clear}$.

Evaporation Heat Flux. The heat flux q_e required to evaporate water from a wet surface is given by

$$q_e = \rho_{dry\ air} h_m (W_f - W_a) h_{fg} \quad (11)$$

where

- h_m = mass transfer coefficient, ft/h
- W_a = humidity ratio of ambient air, lb_{vapor}/lb_{air}
- W_f = humidity ratio of saturated air at film surface temperature, lb_{vapor}/lb_{air}
- h_{fg} = heat of vaporization (enthalpy difference between saturated water vapor and saturated liquid water), Btu/lb
- $\rho_{dry\ air}$ = density of dry air, lb/ft³

Determination of the mass transfer coefficient is based on the analogy between heat transfer and mass transfer. Details of the analogy are given in Chapter 5 of the 2005 ASHRAE Handbook—Fundamentals. For external flow where mass transfer occurs at the convective surface and the water vapor component is dilute, the following equation relates the mass transfer coefficient h_m to the heat transfer coefficient h_c [Equation (6)]:

$$h_m = \left(\frac{Pr}{Sc}\right)^{2/3} \frac{h_c}{\rho_{dry\ air} c_{p,air}} \quad (12)$$

where Sc = Schmidt number. In applying Equation (11), the values Pr = 0.7 and Sc = 0.6 were used to generate the values in Tables 1 through 4.

The humidity ratios both in the atmosphere and at the surface of the water film are calculated using the standard psychrometric relation given in the following equation (from Chapter 6 of the 2005 ASHRAE Handbook—Fundamentals):

$$W = 0.622 \left(\frac{p_v}{p - p_v} \right) \quad (13)$$

where

- p = atmospheric pressure, psi
- p_v = partial pressure of water vapor, psi

The atmospheric pressure in Equation (13) is corrected for altitude using the following equation (Kuehn et al. 1998):

$$p = p_{std} \left(1 - \frac{Az}{T_o} \right)^{5.265} \quad (14)$$

where

- p_{std} = standard atmospheric pressure, psi
- A = 0.00356 °R/ft
- z = altitude of the location above sea level, ft
- T_o = 518.7 °R

Altitudes of specific locations are found in Chapter 28 of the 2005 ASHRAE Handbook—Fundamentals.

The vapor pressure p_v for the calculation of W_a is equal to the saturation vapor pressure p_s at the dew-point temperature of the air. Saturated conditions exist at the water film surface. Therefore, the vapor pressure used in calculating W_f is the saturation pressure at the film temperature t_f . The saturation partial pressures of water vapor for temperatures above and below freezing are found in tables of the thermodynamic properties of water at saturation or can

be calculated using appropriate equations. Both are presented in Chapter 6 of the 2005 ASHRAE Handbook—Fundamentals.

Heat Flux Calculations. Equations (1) to (14) can be used to determine the required heat fluxes of a snow-melting system. However, calculations must be made for coincident values of snowfall rate, wind speed, ambient temperature, and dew-point temperature (or another measure of humidity). By computing the heat flux for each snowfall hour over a period of several years, a frequency distribution of hourly heat fluxes can be developed. Annual averages or maximums for climatic factors should never be used in sizing a system because they are unlikely to coexist. Finally, it is critical to note that the preceding analysis only describes what is happening at the upper surface of the snow-melting surface. Edge losses and back losses have not been taken into account.

Example 1. During the snowfall that occurred during the 8 PM hour on December 26, 1985, in the Detroit metropolitan area, the following simultaneous conditions existed: air dry-bulb temperature = 17°F, dew-point temperature = 14°F, wind speed = 19.7 mph, and snowfall rate = 0.10 in. of liquid water equivalent per hour. Assuming $L = 20$ ft, Pr = 0.7, and Sc = 0.6, calculate the surface heat flux q_o for a snow-free area ratio of $A_r = 1.0$. The thermodynamic and transport properties used in the calculation are taken from Chapters 6 and 39 of the 2005 ASHRAE Handbook—Fundamentals. The emittance of the wet surface of the heated slab is 0.9.

Solution:

By Equation (3),

$$q_s = 62.4 \times \frac{0.10}{12} [0.49(32 - 17) + 1.0(33 - 32)] = 4.3 \text{ Btu/h} \cdot \text{ft}^2$$

By Equation (4),

$$q_m = 62.4 \times \frac{0.10}{12} \times 143.3 = 74.5 \text{ Btu/h} \cdot \text{ft}^2$$

By Equation (7),

$$Re_L = \frac{19.7 \times 20 \times 5280}{0.49} = 4.24 \times 10^6$$

By Equation (6),

$$h_c = 0.037 \left(\frac{0.0135}{20} \right) (4.24 \times 10^6)^{0.8} (0.7)^{1/3} = 4.44 \text{ Btu/h} \cdot \text{ft}^2 \cdot \text{°F}$$

By Equation (5),

$$q_h = 4.44(33 - 17) + (0.1712 \times 10^{-8})(0.9)(493^4 - 477^4) = 83.5 \text{ Btu/h} \cdot \text{ft}^2$$

By Equation (12),

$$h_m = \left(\frac{0.7}{0.6} \right)^{2/3} \frac{4.44}{0.083 \times 0.24} = 247 \text{ ft/h}$$

Obtain the values of the saturation vapor pressures at the dew-point temperature 14°F and the film temperature 33°F from Table 3 in Chapter 6 of the 2005 ASHRAE Handbook—Fundamentals. Then, use Equation (13) to obtain $W_a = 0.00160$ lb_{vapor}/lb_{air} and $W_f = 0.00393$ lb_{vapor}/lb_{air}. By Equation (11),

$$q_e = 0.083 \times 247(0.00393 - 0.00160) \times 1075 = 51.3 \text{ Btu/h} \cdot \text{ft}^2$$

By Equation (1),

$$q_o = 4.3 + 74.5 + 1.0(83.5 + 51.3) = 214 \text{ Btu/h} \cdot \text{ft}^2 \times 0.2931 = 62.7 \text{ W/ft}^2$$

Note that this is the heat flux needed at the snow-melting surface of the slab. Back and edge losses must be added as discussed in the section on Back and Edge Heat Losses.

Table 1 Frequencies of Snow-Melting Surface Heat Fluxes at Steady-State Conditions^a

Location	Snowfall Hours per Year	Snow-Free Area Ratio, A_r	Heat Fluxes Not Exceeded During Indicated Percentage of Snowfall Hours from 1982 Through 1993, Btu/h·ft ² ^b					
			75%	90%	95%	98%	99%	100%
Albany, NY	156	1	89	125	149	187	212	321
		0.5	60	86	110	138	170	276
		0	37	62	83	119	146	276
Albuquerque, NM	44	1	70	118	168	191	242	393
		0.5	51	81	96	117	156	229
		0	30	46	61	89	92	194
Amarillo, TX	64	1	113	150	168	212	228	318
		0.5	71	88	108	124	142	305
		0	24	46	62	89	115	292
Billings, MT	225	1	112	164	187	212	237	340
		0.5	64	89	102	116	128	179
		0	22	33	45	60	68	113
Bismarck, ND	158	1	151	199	231	275	307	477
		0.5	83	107	124	148	165	243
		0	16	30	39	60	73	180
Boise, ID	85	1	58	79	100	126	146	203
		0.5	38	52	66	80	89	164
		0	22	31	40	53	62	164
Boston, MA	112	1	96	137	165	202	229	365
		0.5	65	95	112	149	190	365
		0	37	75	93	121	172	365
Buffalo, NY	292	1	115	166	210	277	330	570
		0.5	68	97	127	164	188	389
		0	23	39	55	93	112	248
Burlington, VT	204	1	91	130	154	184	200	343
		0.5	58	78	92	113	128	343
		0	23	40	55	78	94	343
Cheyenne, WY	224	1	119	172	201	229	261	354
		0.5	70	97	111	132	149	288
		0	16	37	52	77	100	285
Chicago, IL, O'Hare International Airport	124	1	96	126	153	186	235	521
		0.5	58	77	94	113	137	265
		0	23	38	53	75	83	150
Cleveland, OH	188	1	85	124	157	195	230	432
		0.5	52	73	92	118	147	235
		0	23	37	47	69	92	225
Colorado Springs, CO	159	1	89	135	167	202	219	327
		0.5	57	82	99	124	140	218
		0	23	45	61	87	112	165
Columbus, OH, International Airport	92	1	71	101	123	149	175	328
		0.5	45	60	71	87	95	184
		0	15	30	45	60	62	135
Des Moines, IA	127	1	120	174	208	255	289	414
		0.5	74	102	120	149	180	310
		0	24	46	69	94	108	231
Detroit, MI, Metro Airport	153	1	92	130	156	192	212	360
		0.5	57	77	94	118	134	227
		0	23	38	47	75	89	194
Duluth, MN	238	1	123	171	201	238	250	370
		0.5	71	97	114	131	142	213
		0	22	32	46	68	77	196
Ely, NV	153	1	67	97	116	134	162	242
		0.5	44	66	83	111	129	241
		0	23	45	67	97	112	240
Eugene, OR	18	1	59	110	139	165	171	224
		0.5	47	77	93	119	122	164
		0	30	53	70	102	120	164
Fairbanks, AK	288	1	91	121	144	174	202	391
		0.5	52	68	78	94	108	200
		0	15	23	31	40	48	87
Baltimore, MD, BWI Airport	56	1	87	139	172	235	282	431
		0.5	69	108	147	200	238	369
		0	46	84	119	181	214	306
Great Falls, MT	233	1	123	171	193	233	276	392
		0.5	71	93	107	129	144	210
		0	17	31	45	60	75	143
Indianapolis, IN	96	1	95	134	158	194	215	284
		0.5	58	80	96	116	124	209
		0	23	38	52	83	99	209

^aHeat fluxes are at the snow-melting surface only. See text for calculation of back and edge heat loss fluxes.^bMultiply values by 0.2931 to convert to W/ft².

Table 1 Frequencies of Snow-Melting Surface Heat Fluxes at Steady-State Conditions^a (Continued)

Location	Snowfall Hours per Year	Snow-Free Area Ratio, A_r	Heat Fluxes Not Exceeded During Indicated Percentage of Snowfall Hours from 1982 Through 1993, Btu/h·ft ² ^b					
			75%	90%	95%	98%	99%	100%
Lexington, KY	50	1	81	108	123	150	170	233
		0.5	49	65	74	85	95	197
		0	16	30	39	46	55	162
Madison, WI	161	1	99	138	164	206	241	449
		0.5	61	82	98	129	163	245
		0	23	39	60	91	113	194
Memphis, TN	13	1	106	141	172	200	206	213
		0.5	75	96	115	118	130	157
		0	40	75	76	90	97	123
Milwaukee, WI	161	1	101	135	164	196	207	431
		0.5	62	83	101	128	147	246
		0	23	46	68	98	120	239
Minneapolis-St. Paul, MN	199	1	119	169	193	229	254	332
		0.5	73	99	114	138	154	287
		0	23	45	61	91	113	245
New York, NY, JFK Airport	61	1	91	134	164	207	222	333
		0.5	63	93	118	145	164	325
		0	38	68	86	113	133	316
Oklahoma City, OK	35	1	117	168	215	248	260	280
		0.5	72	101	123	133	144	208
		0	24	46	68	78	113	190
Omaha, NE	94	1	108	148	189	222	259	363
		0.5	65	89	105	128	135	186
		0	23	38	60	90	100	136
Peoria, IL	91	1	95	139	166	201	227	436
		0.5	58	83	99	119	130	250
		0	23	38	53	76	92	228
Philadelphia, PA, International Airport	56	1	94	129	154	208	246	329
		0.5	65	90	112	162	185	267
		0	38	63	79	111	150	225
Pittsburgh, PA, International Airport	168	1	83	125	159	194	219	423
		0.5	51	75	94	111	129	216
		0	16	31	46	68	77	136
Portland, ME	157	1	120	168	195	234	266	428
		0.5	76	108	132	168	199	376
		0	39	67	90	130	152	324
Portland, OR	15	1	50	78	102	177	239	296
		0.5	39	55	81	114	130	199
		0	23	45	60	78	102	128
Rapid City, SD	177	1	139	203	252	312	351	482
		0.5	78	111	132	164	183	245
		0	16	30	38	53	65	179
Reno, NV	63	1	50	72	89	116	137	191
		0.5	36	55	75	105	115	172
		0	23	45	68	91	113	159
Salt Lake City, UT	142	1	52	77	89	110	120	171
		0.5	39	62	76	96	104	171
		0	30	60	75	89	104	171
Sault Ste. Marie, MI	425	1	112	153	183	216	249	439
		0.5	66	88	104	125	142	239
		0	23	37	47	68	83	188
Seattle, WA	27	1	56	107	138	171	205	210
		0.5	45	72	97	122	133	175
		0	37	52	75	96	123	151
Spokane, WA	144	1	67	98	116	141	159	227
		0.5	45	61	73	84	95	145
		0	23	37	45	54	67	112
Springfield, MO	58	1	110	155	179	215	224	292
		0.5	70	95	117	142	171	240
		0	32	54	76	115	129	227
St. Louis, MO, International Airport	62	1	97	147	170	193	227	344
		0.5	66	90	105	126	144	269
		0	31	53	68	97	104	194
Topeka, KS	61	1	102	153	192	234	245	291
		0.5	64	92	110	132	139	185
		0	23	39	52	68	84	167
Wichita, KS	60	1	115	163	209	248	285	326
		0.5	71	96	116	137	153	168
		0	24	45	57	75	83	158

^aHeat fluxes are at the snow-melting surface only. See text for calculation of back and edge heat loss fluxes.^bMultiply values by 0.2931 to convert to W/ft².

Weather Data and Heat Flux Calculation Results

[Table 1](#) shows frequencies of snow-melting loads for 46 cities in the United States (Ramsey et al. 1999). For the calculations, the temperature of the surface of the snow-melting slab was taken to be 33°F. Any time the ambient temperature was below 32°F and it was not snowing, it was assumed that the system was idling (i.e., that heat was supplied to the slab so that melting would start immediately when snow began to fall).

Weather data were taken for the years 1982 through 1993. These years were selected because of their completeness of data. The weather data included hourly values of the precipitation amount in equivalent depth of liquid water, precipitation type, ambient dry-bulb and dew-point temperatures, wind speed, and sky cover. All weather elements for 1982 to 1990 were obtained from the *Solar and Meteorological Surface Observation Network 1961 to 1990 (SAMSON), Version 1.0* (NCDC 1993). For 1991 to 1993, all weather elements except precipitation were taken from DATSAV2 data obtained from the National Climatic Data Center as described in Colliver et al. (1998). The precipitation data for these years were taken from NCDC's *Hourly Cooperative Dataset* (NCDC 1990).

All wind speeds used were taken directly from the weather data. Wind speed V_{met} is usually measured at height of approximately 33 ft. As indicated in the section on Heat Balance, the heat and mass transfer coefficients are functions of a characteristic dimension of the snow-melting slab. The dimension used in generating the values of [Table 1](#) was 20 ft. Sensitivity of the load to both wind speed and the characteristic dimension is included in [Table 2](#). During snowfall, the sky temperature was taken as equal to the ambient temperature.

The first data column in [Table 1](#) presents the average number of snowfall hours per year for each location. All surface heat fluxes were computed for snow-free area ratios of 1, 0.5, and 0, and the frequencies of snow-melting loads are presented. The frequency indicates the percentage of time that the required snow-melting surface heat flux does not exceed the value in the table for that ratio.

This table is used to design a snow-melting system for a given level of customer satisfaction depending on criticality of function. For example, although a heliport at the rooftop of a hospital may require almost 100% satisfactory operation at a snow-free ratio of 1, a residential driveway may be considered satisfactory at 90% and $A_r = 0.5$ design conditions. To optimize cost, different percentiles may be applied to different sections of the slab. For example, train station slab embark/disembark areas may be designed for a higher percentile and A_r than other sections.

[Figures 1](#) and [2](#) show the distribution in the United States of snow-melting surface heat fluxes for snow-free area ratios of 1.0 and 0, respectively. The values presented satisfy the loads 99% of the time (as listed in the 99% column of [Table 1](#)). Local values can be approximated by interpolating between values given on the figure; however, extreme care must be taken because special local climatological conditions exist for many areas (e.g., lake effect snow). Both altitude and geography should be considered in making interpolations. Generally, locations in the northern plains of the United States require the maximum snow-melting heat flux (Chapman 1999).

Example for Surface Heat Flux Calculation Using [Table 1](#)

Example 2. Consider the design of a system for Albany, New York, which has an installed heat flux capacity at the top surface of approximately 149 Btu/h·ft². Based on data in [Table 1](#), this system will keep the surface completely free of snow 95% of the time. Because there are 156 snowfall hours in an average year, this design would have some accumulation of snow approximately 8 h per year (the remaining 5% of the 156 h). This design will also meet the load for more than 98% of the time (i.e., more than 153 of the 156 snowfall hours) at an area ratio of 0.5 and more than 99% of the time for an area ratio of 0. $A_r = 0.5$ means that there is a thin layer of snow over all or part of the slab such that it acts as though half the slab is insulated by a snow layer; $A_r = 0$ means

that the snow layer is sufficient to insulate the surface from heat and evaporation losses, but that snow is melting at the base of this layer at the same rate that it is falling on the top of the layer.

Therefore, the results for this system can be interpreted to mean the following (all times are rounded to the nearest hour):

- For all but 8 h of the year, the slab will be snow-free.
- For the less than 5 h between the 95% and 98% nonexceedance values, there will be a thin build-up of snow on part of the slab.
- For the less than 2 h between the 98% and 99% nonexceedance values, snow will accumulate on the slab to a thickness at which the snow blanket insulates the slab, but the thickness will not increase beyond that level.
- For less than 2 h, the system can not keep up with the snowfall.

An examination of the 100% column shows that to keep up with the snowfall the last 1% of the time, in this case less than 2 h for an average year, would require a system capacity of approximately 276 Btu/h·ft²; to attempt to keep the slab completely snow-free the entire season requires a capacity of 321 Btu/h·ft². Based on this interpretation, the designer and customer must decide the acceptable operating conditions. Note that the heat flux values in this example do not include back or edge losses, which must be added in sizing energy source and heat delivery systems.

Sensitivity of Design Surface Heat Flux to Wind Speed and Surface Size

Some snow-melting systems are in sheltered areas, whereas others may be in locations where surroundings create a wind tunnel effect. Similarly, systems vary in size from the baseline characteristic length of 20 ft. For example, sidewalks exposed to a crosswind may have a characteristic length on the order of 5 ft. In such cases, the wind speed will be either less than or greater than the meteorological value V_{met} used in [Table 1](#). To establish the sensitivity of the surface heat flux to wind speed and characteristic length, calculations were performed at combinations of wind speeds $0.5V_{met}$, V_{met} , and $2V_{met}$ and L values of 5 ft and 20 ft for area ratios A_r of 1.0 and 0.5. Wind speed and system size do not affect the load values for $A_r = 0$ because the calculations assume that no heat or mass transfer from the surface occurs at this condition. [Table 2](#) presents a set of mean values of multipliers that can be applied to the loads presented in [Table 1](#); these multipliers were established by examining the effect on the 99% nonexceedance values. The ratio of V to V_{met} in a given design problem may be determined from information given in Chapter 15 of the 2005 *ASHRAE Handbook—Fundamentals*. The closest ratio in [Table 2](#) can then be selected. The designer is cautioned that these are to be used only as guidelines on the effect of wind speed and size variations.

Back and Edge Heat Losses

The surface heat fluxes in [Table 1](#) do not account for heat losses from the back and edges of the slab. Adlam (1950) demonstrated that these back and edge losses may vary from 4 to 50%, depending on factors such as slab construction, operating temperature, ground temperature, and back and edge insulation and exposure. With the construction shown in [Figure 3](#) or [Figure 5](#) and ground temperature of 40°F at a depth of 24 in., back losses are approximately 20%. Higher losses occur with (1) colder ground, (2) more cover over the slab, or (3) exposed back, such as on bridges or parking decks.

Transient Analysis of System Performance

Determination of snow-melting surface heat fluxes as described in Equations (1) to (14) is based on steady-state analysis. Snow-melting systems generally have heating elements embedded in material of significant thermal mass. Transient effects, such as occur when the system is started, may be significant. A transient analysis method was developed by Spittle et al. (2002) and showed that particular storm conditions could change the snow-melting surface heat flux requirement significantly, depending on the precipitation rate at a particular time in the storm. It is therefore difficult to

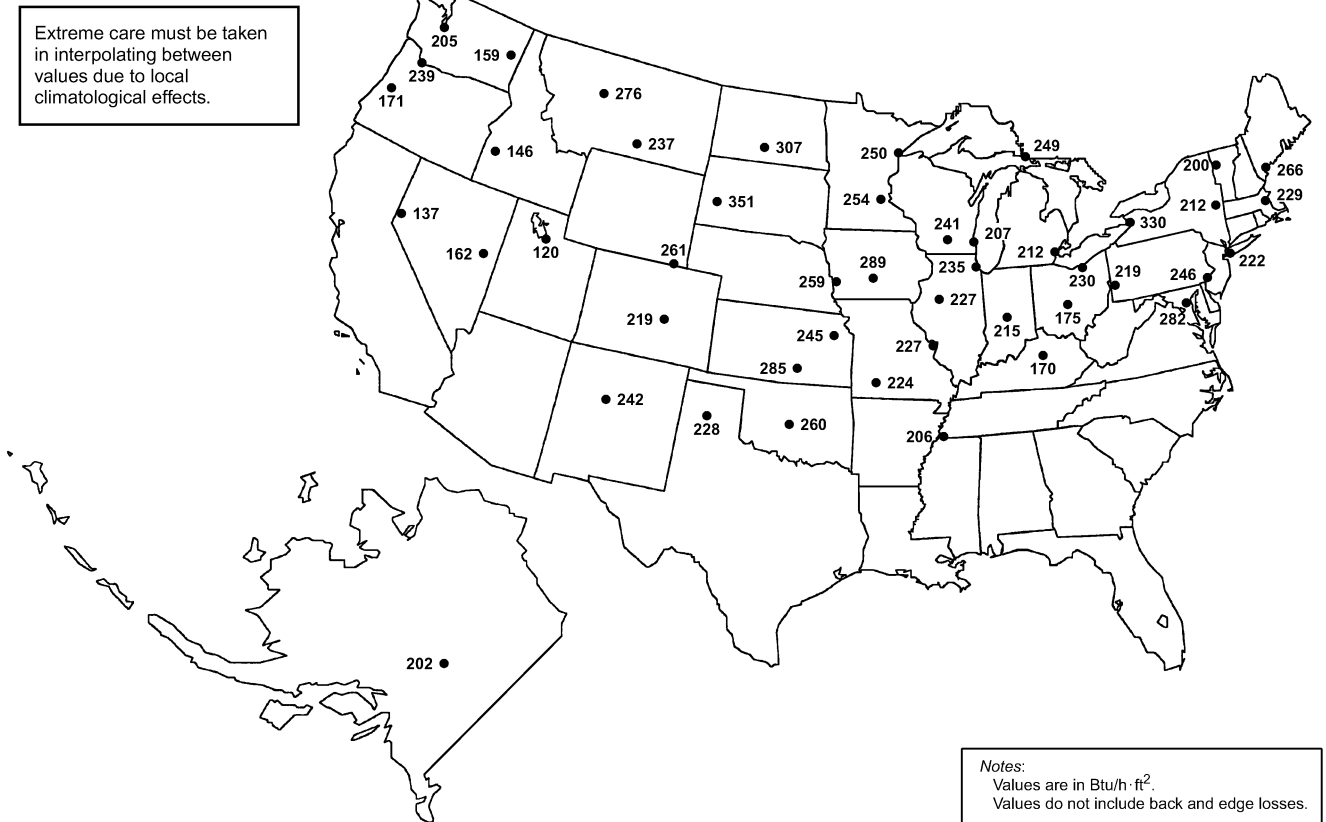

Fig. 1 Snow-Melting Surface Heat Fluxes Required to Provide Snow-Free Area Ratio of 1.0 for 99% of Time

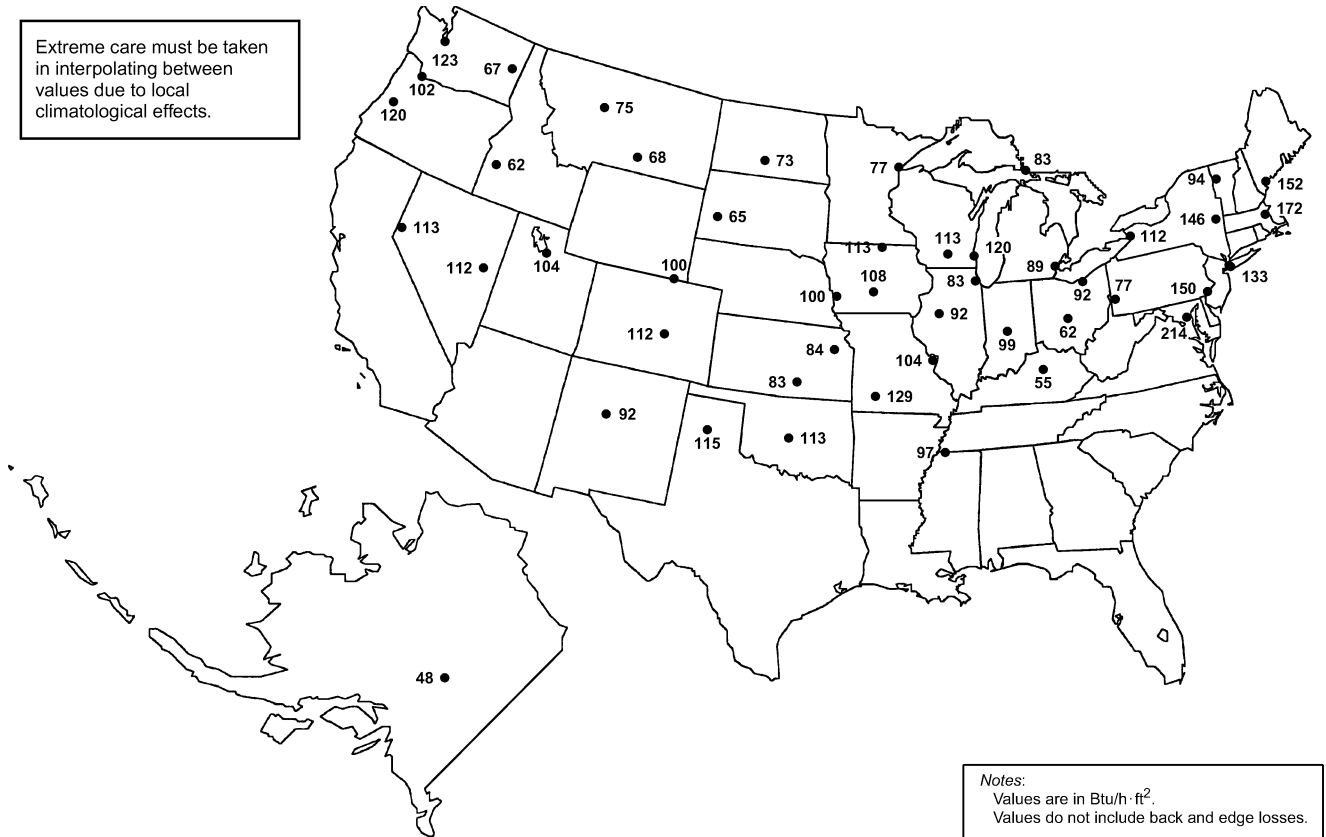

Fig. 2 Snow-Melting Surface Heat Fluxes Required to Provide Snow-Free Area Ratio of 0 for 99% of Time

Table 2 Mean Sensitivity of Snow-Melting Surface Heat Fluxes to Wind Speed and Slab Length

For loads not exceeded during 99% of snowfall hours, 1982 through 1993

Snow-Free Area Ratio, A_r	Ratio of Flux at Stated Condition to Flux at $L = 20$ ft and $V = V_{met}$				
	$L = 20$ ft		$L = 5$ ft		
	$V = 0.5V_{met}$	$V = 2V_{met}$	$V = V_{met}$	$V = 0.5V_{met}$	$V = 2V_{met}$
1	0.7	1.6	1.2	0.8	2.0
0.5	0.8	1.4	1.2	0.9	1.7
0	1.0	1.0	1.0	1.0	1.0

Note: Based on data from U.S. locations.

L = characteristic length

V_{met} = meteorological wind speed from NCDC

find simple general design rules that account for transient effects. To keep slab surfaces clear from snow during the first hour of the snowstorm, when the system is just starting to operate, heat fluxes up to five times greater than those indicated by steady-state analysis could be required. In general, greater heat input is required for greater spacing and greater depth of the heating elements in the slab; however, because of transient effects, this is not always true.

Transient analysis (Spitler et al. 2002) has also been used to examine back and edge losses. Heat fluxes because of back losses in systems without insulation ranged from 10 to 30% of the surface heat flux, depending primarily on the particular storm data, though higher losses occurred where heating elements were embedded deeper in the slab. In cases where 2 in. of insulation was applied below the slab, back losses were significantly reduced, to 1 to 4%. Although peak losses were reduced, the surface heat fluxes required to melt the snow were not significantly affected by the presence of insulation, because transient effects at the start of system operation drive the peak design surface heat fluxes. Edge losses ranged from 15 to 35% of the heat delivered by the heating element nearest the edge. This may be converted to an approximately equivalent surface heat flux percentage by reducing the snow-melting surface length and width by an amount equal to two-thirds of the heating element spacing in the slab. Then the design surface heat flux may be adjusted by the ratio of the actual snow-melting surface area to the reduced surface area as described here. The effect of edge insulation was found to be similar to that at the back of the slab. Although edge insulation does not reduce the surface heat flux requirement significantly, increased snow accumulation at the edges should be expected.

Annual Operating Data

Annual operating data for the cities in [Table 1](#) are presented in [Table 3](#). Melting and idling hours are summarized in this table along with the energy per unit area needed to operate the system during an average year based on calculations for the years 1982 to 1993. Back and edge heat losses are not included in the energy values in [Table 3](#). Data are presented for snow-free area ratios of 1.0, 0.5, and 0.

The energy per unit area values are based on systems designed to satisfy the loads 99% of the time (i.e., at the levels indicated in the 99% column in [Table 1](#)) for each A_r value. The energy use for each melting hour is taken as either (1) the actual energy required to maintain the surface at 33°F or (2) the design output, whichever is less. The design snow-melting energy differs, of course, depending on whether the design is for $A_r = 1.0, 0.5,$ or 0 ; therefore, the annual melting energy differs as well.

The idling hours include all non-snowfall hours when the ambient temperature is below 32°F. The energy consumption for each idling hour is based on either (1) the actual energy required to maintain the surface at 32°F or (2) the design snow-melting energy, whichever is less.

In [Table 3](#), the column labeled “2% Min. Snow Temp.” is the temperature below which only 2% of the snowfall hours occur. This table may only be used to predict annual operating costs. Use [Table 1](#) for system sizing.

Annual Operating Cost Example

Example 3. A snow-melting system of 2000 ft² is to be installed in Chicago. The application is considered critical enough that the system is designed to remain snow-free 99% of the time. [Table 3](#) shows that the annual energy requirement to melt the snow is 8501 Btu/ft². Assuming a fossil fuel cost of \$8 per 10⁶ Btu, an electric cost of \$0.07 per kWh, and back loss at 30%, find and compare the annual cost to melt snow with hydronic and electric systems. For the hydronic system, boiler combustion efficiency is 0.85 and energy distribution efficiency is 0.90.

Solution: Operating cost O may be expressed as follows:

$$O = \frac{A_t Q_a F}{[1 - (B/100)](\eta_b \eta_d)} \quad (15)$$

where

O = annual operating cost \$/yr

A_t = total snow-melting area, ft²

Q_a = annual snow-melting or idling energy requirement, Btu/ft² or kWh/ft²

F = primary energy cost \$/Btu or \$/kWh

B = back heat loss percentage, %

η_b = combustion efficiency of boiler (or COP of a heat pump in heating mode), dimensionless. If a waste energy source is directly used for snow-melting or idling purposes, the combustion efficiency term is neglected.

η_d = energy distribution efficiency, dimensionless (in an electric system, efficiencies may be taken to be 1)

Operating cost for a hydronic system is

$$O = \frac{(2000)(8501)(8 \times 10^{-6})}{\left[1 - \left(\frac{30}{100}\right)\right](0.85)(0.90)} = \$254/\text{yr}$$

Operating cost for an electric system is

$$O = \frac{[2000(8501 \times 0.2931 \times 10^{-3})(0.07)]}{1 - (30/100)} = \$498/\text{yr}$$

It is desirable to use waste or alternative energy resources to minimize operating costs. If available in large quantities, low-temperature energy resources may replace primary energy resources, because the temperature requirement is generally moderate (Kilkis 1995). Heat pipes may also be used to exploit ground heat (Shirakawa et al. 1985).

SLAB DESIGN

Either concrete or asphalt slabs may be used for snow-melting systems. The thermal conductivity of asphalt is less than that of concrete; pipe or electric cable spacing and required fluid temperatures are thus different. Hot asphalt may damage plastic or electric (except mineral-insulated cable) snow-melting systems unless adequate precautions are taken. For specific recommendations, see the sections on Hydronic System Design and Electric System Design.

Concrete slabs containing hydronic or electric snow-melting apparatus must have a subbase, expansion-contraction joints, reinforcement, and drainage to prevent slab cracking; otherwise, crack-induced shearing or tensile forces could break the pipe or cable. The pipe or cable must not run through expansion-contraction joints, keyed construction joints, or control joints (dummy grooves); however, the pipe or cable may be run under 0.12 in. score marks or saw cuts (block and other patterns). Sleeved pipe is allowed to cross expansion joints (see [Figure 4](#)). Control joints must be placed wherever the slab changes size or incline. The maximum distance between control joints for ground-supported slabs should be less than 15 ft, and the length should be no greater than twice the width,

Table 3 Annual Operating Data at 99% Satisfaction Level of Heat Flux Requirement

City	Time, h/yr		2% Min. Snow Temp., °F	Annual Energy Requirement per Unit Area at Steady-State Conditions, ^a Btu/ft ² ^b					
				System Designed for $A_r = 1$		System Designed for $A_r = 0.5$		System Designed for $A_r = 0$	
	Melting	Idling		Melting	Idling	Melting	Idling	Melting	Idling
Albany, NY	156	1,883	9.3	10,132	109,230	7,252	109,004	4,371	108,420
Albuquerque, NM	44	954	16.3	2,455	38,504	1,729	38,495	984	38,332
Amarillo, TX	64	1,212	6.8	5,276	62,557	3,314	62,136	1,357	61,170
Billings, MT	225	1,800	-10.8	17,299	116,947	10,526	111,803	3,716	91,360
Bismarck, ND	158	2,887	-8.8	16,295	207,888	9,321	201,565	2,300	157,503
Boise, ID	85	1,611	5.3	3,543	74,724	2,449	73,015	1,345	68,456
Boston, MA	112	1,273	16.3	7,694	77,992	5,455	77,907	3,218	77,747
Buffalo, NY	292	1,779	3.8	23,929	105,839	14,735	105,521	5,563	101,945
Burlington, VT	204	2,215	4.3	13,182	147,122	8,485	143,824	3,783	134,634
Cheyenne, WY	224	2,152	-15.8	20,061	126,714	11,931	125,635	3,782	120,915
Chicago, IL, O'Hare International Airport	124	1,854	3.8	8,501	116,663	5,402	112,763	2,252	100,427
Cleveland, OH	188	1,570	8.8	11,419	86,539	7,359	85,470	3,208	80,851
Colorado Springs, CO	159	1,925	-8.8	11,137	97,060	7,089	96,847	3,026	96,244
Columbus, OH, International Airport	92	1,429	12.8	4,581	71,037	2,972	68,002	1,367	62,038
Des Moines, IA	127	1,954	-1.8	10,884	128,140	6,796	125,931	2,654	116,545
Detroit, MI, Metro Airport	153	1,781	11.3	10,199	104,404	6,467	102,289	2,704	95,777
Duluth, MN	238	3,206	0.3	20,838	251,218	12,423	236,657	3,969	187,820
Ely, NV	153	2,445	13.3	7,421	141,288	5,268	139,242	3,098	136,920
Eugene, OR	18	481	15.8	841	17,018	634	16,997	429	16,992
Fairbanks, AK	288	4,258	-15.8	19,803	343,674	11,700	318,880	3,559	194,237
Baltimore, MD, BWI Airport	56	957	16.3	3,827	45,132	2,970	45,132	2,121	45,130
Great Falls, MT	233	1,907	-15.8	19,703	123,801	11,731	120,603	3,736	101,712
Indianapolis, IN	96	1,473	10.8	6,558	80,942	4,132	78,532	1,705	75,926
Lexington, KY	50	1,106	13.3	2,696	54,084	1,718	52,278	733	45,859
Madison, WI	161	2,308	5.3	11,404	149,363	7,279	147,112	3,094	140,108
Memphis, TN	13	473	12.8	1,010	21,756	691	21,518	373	21,102
Milwaukee, WI	161	1,960	7.3	11,678	127,230	7,564	123,960	3,431	119,945
Minneapolis-St. Paul, MN	199	2,513	0.3	16,532	183,980	10,325	178,495	4,097	166,921
New York, NY, JFK Airport	61	885	18.3	4,193	50,680	2,988	50,467	1,797	50,049
Oklahoma City, OK	35	686	6.8	2,955	40,957	1,850	39,725	741	38,308
Omaha, NE	94	1,981	-2.3	7,425	124,274	4,613	119,565	1,790	112,700
Peoria, IL	91	1,748	2.3	6,544	104,380	4,078	100,581	1,606	94,045
Philadelphia, PA, International Airport	56	992	18.3	3,758	50,494	2,669	50,412	1,588	50,203
Pittsburgh, PA, International Airport	168	1,514	9.3	10,029	79,312	6,350	77,750	2,626	72,361
Portland, ME	157	1,996	7.3	13,318	115,248	8,969	115,196	4,630	114,836
Portland, OR	15	329	21.8	623	13,399	464	13,194	310	12,918
Rapid City, SD	177	2,154	-4.8	16,889	137,523	9,738	135,024	2,535	106,102
Reno, NV	63	1,436	16.3	2,293	54,713	1,792	54,706	1,302	54,703
Salt Lake City, UT	142	1,578	16.3	5,263	70,254	4,271	69,927	3,286	69,927
Sault Ste. Marie, MI	425	2,731	-0.3	34,249	176,517	20,779	174,506	7,250	155,508
Seattle, WA	27	260	17.8	1,212	10,482	943	10,473	682	10,452
Spokane, WA	144	1,832	10.8	6,909	81,000	4,721	79,177	2,512	75,659
Springfield, MO	58	1,108	6.8	4,401	57,165	2,950	56,929	1,503	56,238
St. Louis, MO, International Airport	62	1,150	6.8	4,516	64,668	2,981	63,428	1,446	60,764
Topeka, KS	61	1,409	-1.8	4,507	75,598	2,821	74,028	1,126	68,402
Wichita, KS	60	1,223	0.3	4,961	69,187	3,106	67,828	1,229	60,991

^aDoes not include back and edge heat losses.^bMultiply values listed by 2.93×10^{-4} to convert to kWh/ft².

except for ribbon driveways or sidewalks. In ground-supported slabs, most cracking occurs during the early cure. Depending on the amount of water used in the concrete mix, shrinkage during cure may be up to 0.75 in. per 100 ft. If the slab is more than 15 ft long, the concrete does not have sufficient strength to overcome friction between it and the ground while shrinking during the cure period.

If the slabs are poured in two separate layers, the top layer, which contains the snow-melting apparatus, usually does not contribute toward total slab strength; therefore, the lower layer must be designed to provide the total strength.

The concrete mix of the top layer should give maximum weatherability. The compressive strength should be 4000 to 5000 psi; recommended slump is 3 in. maximum, 2 in. minimum. Aggregate size and air content should be as follows:

Table 4 Required Aggregate Size and Air Content

Maximum Size Crushed Rock Aggregate, in.	Air Content, %
2.5	5 ± 1
1	6 ± 1
0.5	7.5 ± 1

Source: Potter (1967).

Note: Do not use river gravel or slag.

The pipe or cable may be placed in contact with an existing sound slab (either concrete or asphalt) and then covered as described in the sections on Hydronic System Design and Electric System Design. If there are signs of cracking or heaving, the slab should be replaced. Pipe or cable should not be placed over existing expansion-contraction, control, or construction joints. The finest grade of asphalt is best for the top course; stone diameter should not exceed 0.38 in.

A moisture barrier should be placed between any insulation and the fill. If insulation is used, it should be nonhygroscopic. The joints in the barrier should be sealed and the fill made smooth enough to eliminate holes or gaps for moisture transfer. Also, the edges of the barrier should be flashed to the surface of the slab to seal the ends.

Snow-melting systems should have good surface drainage. When the ambient air temperature is 32°F or below, runoff from melting snow freezes immediately after leaving the heated area. Any water that gets under the slab also freezes when the system is shutdown, causing extreme frost heaving. Runoff should be piped away in drains that are heated or below the frost line. If the snow-melting surface is inclined (e.g., a ramp), surface runoff may collect at the lowest point. In addition to effective drainage down the ramp, the adjacent area may require heating to prevent freezing the accumulated runoff.

The area to be protected by the snow-melting system must first be measured and planned. For total snow removal, hydronic or electric heat must cover the entire area. In larger installations, it may be desirable to melt snow and ice from only the most frequently used areas, such as walkways and wheel tracks for trucks and autos. Planning for separate circuits should be considered so that areas within the system can be heated individually, as required.

Where snow-melting apparatus must be run around obstacles (e.g., a storm sewer grate), the pipe or cable spacing should be uniformly reduced. Because some drifting will occur adjacent to walls or vertical surfaces, extra heating capacity should be provided in these areas, and if possible also in the vertical surface. Drainage flowing through the area expected to be drifted tends to wash away some snow.

CONTROL

Manual Control

Manual operation is strictly by on-off control; an operator must activate and deactivate the system when snow falls. The system should be started at an idling load before snowfall, when-

ever possible, to minimize thermal stresses in the system and the slab. The system must continue to operate until all the snow on the slab melts and evaporates.

Automatic Control

If the snow-melting system is not turned on until snow starts falling, it may not melt snow effectively for several hours, giving additional snowfall a chance to accumulate and increasing the time needed to melt the area. Automatic controls provide satisfactory operation by activating the system when light snow starts, allowing adequate warm-up before heavy snowfall develops. Automatic deactivation reduces operating costs.

Snow Detectors. Snow detectors monitor precipitation and temperature. They allow operation only when snow is present and may incorporate a delay-off timer. Snow detectors located in the heated area activate the snow-melting system when precipitation (snow) occurs at a temperature below the preset slab temperature (usually 40°F). Another type of snow detector is mounted above ground, adjacent to the heated area, without cutting into the existing system; however, it does not detect tracked or drifting snow. Both types of sensors should be located so that they are not affected by overhangs, trees, blown snow, or other local conditions.

Slab Temperature Sensor. To limit energy waste during normal and light snow conditions, it is common to include a remote temperature sensor installed midway between two pipes or cables in the slab; the set point is adjusted between 40 and 60°F. Thus, during mild weather snow conditions, the system is automatically modulated or cycled on and off to keep the slab temperature (at the sensor) at set point.

Outdoor Thermostat. The control system may include an outdoor thermostat that deactivates the system when the outdoor ambient temperature rises above 35 to 40°F as automatic protection against accidental operation in summer or mild weather.

Control Selection

For optimum operating convenience and minimum operating cost, all of the previously mentioned controls should be incorporated in the snow-melting system.

Operating Cost

To evaluate operating cost during idling or melting, use the annual output data from [Table 3](#). Idling and melting data are based on slab surface temperature control at 32°F during idling, which requires a slab temperature sensor. Without a slab temperature sensor, operating costs will be substantially higher.

HYDRONIC SYSTEM DESIGN

Hydronic system design includes selection of the following components: (1) heat transfer fluid, (2) piping, (3) fluid heater, (4) pump(s) to circulate the fluid, and (5) controls. With concrete slabs, thermal stress is also a design consideration.

Heat Transfer Fluid

Various fluids, including brine, oils, and glycol-water, are suitable for transferring heat from the fluid heater to the slab. Freeze protection is essential because most systems will not be operated continuously in subfreezing weather. Without freeze protection, power loss or pump failure could cause freeze damage to the piping and slab.

Brine is the least costly heat transfer fluid, but it has a lower specific heat than glycol. Using brine may be discouraged because of the cost of heating equipment that resists its corrosive potential.

Although **heat transfer oils** are not corrosive, they are more expensive than brine or glycol and have a lower specific heat and higher viscosity. Petroleum distillates used in snow-melting systems are classified as nonflammable but have fire points between

300 and 350°F. When oils are used as heat transfer fluids, any oil dripping from pump seals should be collected. It is good practice to place a barrier between the oil lines and the boiler so that a flashback from the boiler cannot ignite a possible oil leak. Other nonflammable fluids, such as those used in some transformers, can be used as antifreeze.

Glycols (ethylene glycol and propylene glycol) are the most popular in snow-melting systems because of their moderate cost, high specific heat, and low viscosity; ease of corrosion control is another advantage. Automotive glycols containing silicates are not recommended because they can cause fouling, pump seal wear, fluid gelation, and reduced heat transfer. The piping should be designed for periodic addition of an inhibitor. Glycols should be tested annually to determine any change in reserve alkalinity and freeze protection. Only inhibitors obtained from the manufacturer of the glycol should be added. Heat exchanger surfaces should be kept below 285°F, which corresponds to about 40 psig steam. Temperatures above 300°F accelerate deterioration of the inhibitors.

Because ethylene glycol and petroleum distillates are toxic, no permanent connection should be installed between the snow-melting system and the drinking water supply. Gordon (1950) discusses precautions concerning internal corrosion, flammability, toxicity, cleaning, joints, and hook-up that should be taken during installation of hydronic piping. The properties of brine and glycol are discussed in Chapter 21 of the 2005 *ASHRAE Handbook—Fundamentals*. The effect of glycol on system performance is detailed in Chapter 12 of the 2004 *ASHRAE Handbook—HVAC Systems and Equipment*.

Piping

Piping may be metal, plastic, or ethylene-propylene terpolymer (EPDM). Steel, iron, and copper pipes have long been used, but steel and iron may corrode rapidly if the pipe is not shielded by a coating and/or cathodic protection. Both the use of salts for deicing and elevated temperature accelerate corrosion of metallic components. NACE (1978) states that the corrosion rate roughly doubles for each 18°F rise in temperature.

Chapman (1952) derived the equation for the fluid temperature required to provide an output q_o . For construction as shown in [Figure 3](#), the equation is

$$t_m = 0.5q_o + t_f \quad (16)$$

where t_m = average fluid (antifreeze solution) temperature, °F. Equation (16) applies to 1 in. as well as 3/4 in. IPS pipe ([Figure 3](#)).

Design information about heated slabs given in Chapter 6 of the 2004 *ASHRAE Handbook—HVAC Systems and Equipment* may be used for all other types of slab construction, pipe spacing, and pipe material. In using these design equations, snow cover or water film on the slab may be treated as surface covers.

For specific conditions or for cities other than those given in [Table 1](#), Equations (1) and (16) are used. [Table 5](#) gives solutions to these equations at a relative humidity of 80%. Splitting the surface heat flux among four components as in Equation (1) also affects the required water temperature; therefore, Equation (16) and [Table 5](#) should be used with caution. [Table 5](#) may also be used to determine successful systems operation conditions. For example, if a system as shown in [Figure 3](#) is designed for 250 Btu/h·ft², it will satisfy eight severe snow conditions such as 10°F, 0.16 in./h, and 10 mph wind speed (Chapman 1999).

Satisfactory standard practices is to use 3/4 in. pipe or tube on 12 in. centers, unless the snow-melting surface heat flux is too high. If pumping loads require reduced friction, the pipe size can be increased to 1 in., but slab thickness must be increased accordingly. Piping should be supported by a minimum of 2 in. of concrete above and below. This requires a 5 in. slab for 3/4 in. pipe and a 5.4 in. slab for 1 in. pipe.

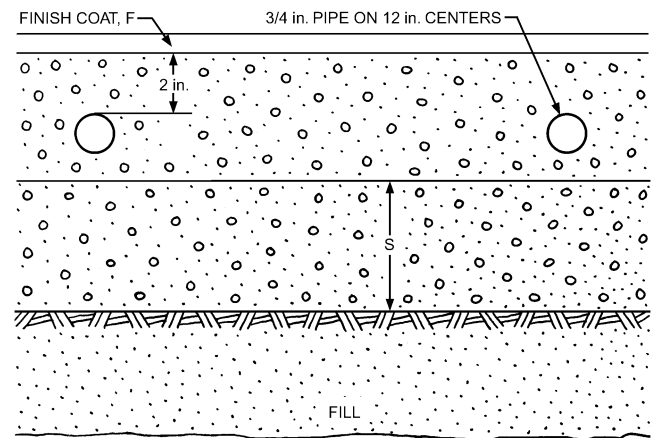

F = depth of finish coat—assumed to be 0.5 in. of concrete. Finish coat may be asphalt, but then cover slab should be reduced from 3 in. Depth of slab should always keep thermal resistance equal to 3 in. of concrete.

S = depth required by structural design (should be at least 2 in. of concrete).

Fig. 3 Detail of Typical Hydronic Snow-Melting System

Plastic Pipe. Plastic [polyethylene (PE), cross-linked polyethylene (PEX)], or multilayer pipe such as PEX-AL-PEX (a PEX inner and outer layer with a middle layer of aluminum) is popular because of lower material cost, lower installation cost, and corrosion resistance. Considerations when using plastic pipe include stress crack resistance, temperature limitations, and thermal conductivity. Heat transfer oils should not be used with plastic pipe.

Plastic pipe is furnished in coils. Smaller pipe can be bent to form a variety of heating panel designs without elbows or joints. Mechanical compression connections can be used to connect heating panel pipe to the larger supply and return piping leading to the pump and fluid heater. PE pipe may be fused using appropriate fittings and fusion equipment. Fusion joining eliminates metallic components and thus the possibility of corrosion in the piping; however, it requires considerable installation training.

When plastic pipe is used, the system must be designed so that the fluid temperature required will not damage the pipe. If a design requires a temperature above the tolerance of plastic pipe, the delivered heat flux will never meet design requirements. The PE temperature limit is typically 140°F. For PEX, the temperature is 200°F (up to 80 psi) sustained fluid temperature, or 180°F (up to 100 psi). A solution to temperature limitations is to decrease the pipe spacing. Closer pipe spacing also helps eliminate striping of snow (unmelted portions between adjacent pipe projections on the surface). Adlam (1950) addresses the parameter of pipe size and the effect of pipe spacing on heat output. A typical solution is summarized in [Table 6](#), which shows a way of designing pipe spacing according to flux requirements. This table also shows adjustments for the effect of more than 2 in. of concrete or paver over the pipe.

Oxygen permeation through plastic pipes may lead to corrosion on metal surfaces in the entire system unless plastic pipes are equipped with an oxygen barrier layer. Otherwise, either a heat exchanger must separate the plastic pipe circuitry from the rest of the system or corrosion-inhibiting additives must be used in the entire hydronic system.

Pipe Installation. It is good design practice to avoid passing any embedded piping through a concrete expansion joint; otherwise, the pipe may be stressed and possibly ruptured. [Figure 4](#) shows a method of protecting piping that must pass through a concrete expansion joint from stress under normal conditions.

After pipe installation, but before slab installation, all piping should be air-tested to about 100 psig. This pressure should be maintained until all welds and connections have been checked for

Table 5 Steady-State Surface Heat Fluxes and Average Fluid Temperature for Hydronic Snow-Melting System in Figure 3
(Average fluid temperature based on 12 in. tube spacing)

s, Rate of Snowfall in/h	A _r	t _a = 0°F			t _a = 10°F			t _a = 20°F			t _a = 30°F			
		Wind Speed V, mph			Wind Speed V, mph			Wind Speed V, mph			Wind Speed V, mph			
		5	10	15	5	10	15	5	10	15	5	10	15	
0.08	1.0	q _o	166	222	272	138	180	217	108	135	159	76	86	94
		t _m	116	144	169	102	123	142	87	100	112	71	76	80
	0.0	q _o	67	67	67	65	65	65	63	63	63	61	61	61
		t _m	66	66	66	65	65	65	64	64	64	63	63	63
0.16	1.0	q _o	233	289	339	203	244	282	171	197	221	136	146	155
		t _m	149	177	202	134	155	174	118	132	144	101	106	110
	0.0	q _o	133	133	133	129	129	129	125	125	125	121	121	121
		t _m	100	100	100	98	98	98	96	96	96	93	93	93
0.25	1.0	q _o	308	363	414	275	317	354	241	268	292	204	214	223
		t _m	187	215	240	171	192	210	154	167	179	135	140	144
	0.0	q _o	208	208	208	202	202	202	195	195	195	189	189	189
		t _m	137	137	137	134	134	134	131	131	131	127	127	127

Note: Table based on a characteristic slab length of 20 ft, standard air pressure, a water film temperature of 33°F, and relative humidity of 80%.

A_r = snow-free area ratio
q_o = slab heating flux, Btu/h · ft²

t_a = atmospheric dry-bulb temperature, °F
t_m = average fluid temperature based on construction shown in Figure 3, °F

Table 6 Typical Dependency of Maximum Heat Flux Deliverable by Plastic Pipes on Pipe Spacing and Concrete Overpour
(Average fluid temperature = 130°F)

Heat Flux, ^a Btu/h · ft ²	Pipe Spacing on Centers, ^b in.
200	12
250	9
300	6
400	4

^aHeat flux per unit area. Includes 30% back loss. Increase to 50% for bridges and structures with exposed back.

^bSpace pipes 1 in. closer for each 1 in. of concrete cover over 2 in. Space pipes 2 in. closer for each 1 in. of brick paver and mortar.

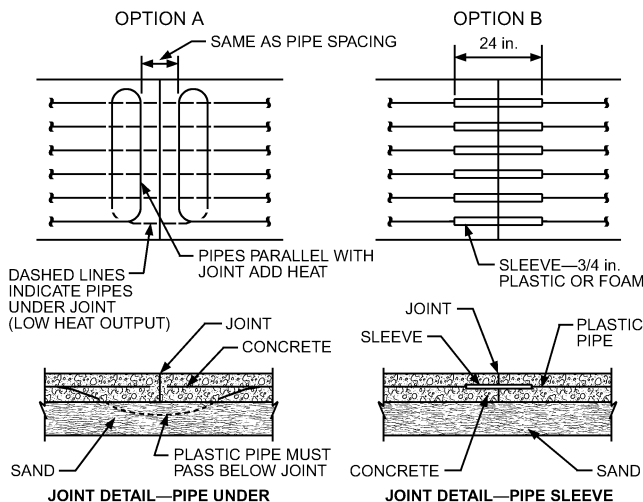

Fig. 4 Piping Details for Concrete Construction

leaks. Isolate the air pressure test to manifold and piping, because boilers or other energy-converting, accumulating, or conditioning equipment may have lower pressure test limits. For example, boilers normally have an air test capability of 30 psi. Testing should not be done with water because (1) small leaks may not be observed

during slab installation; (2) water leaks may damage the concrete during installation; (3) the system may freeze before antifreeze is added; and (4) it is difficult to add antifreeze when the system is filled with water.

Air Control. Because introducing air causes deterioration of the antifreeze, the piping should not be vented to the atmosphere. It should be divided into smaller zones to facilitate filling and allow isolation when service is necessary.

Air can be eliminated from piping during initial filling by pumping the antifreeze from an open container into isolated zones of the piping. A properly sized pump and piping system that maintains adequate fluid velocity, together with an air separator and expansion tank, will keep air from entering the system during operation.

A strainer, sediment trap, or other means for cleaning the piping system may be provided. It should be placed in the return line ahead of the heat exchanger and must be cleaned frequently during initial system operation to remove scale and sludge. A strainer should be checked and cleaned, if necessary, at the start of and periodically during each snow-melting season.

An ASME safety relief valve of adequate capacity should be installed on a closed system.

Fluid Heater

The heat transfer fluid can be heated using any of a variety of energy sources, depending on availability. A fluid heater can use steam, hot water, gas, oil, or electricity. In some applications, heat may be available from secondary sources, such as engine generators, condensate, and other waste heat sources. Other low-temperature waste, or alternative energy resources may also be used with or without heat pumps or heat pipes. In a district heating system, the snow-melting system may be tied to the return piping of the district, which increases the overall temperature drop in the district heating system (Brown 1999).

The design capacity of the fluid heater can be established by evaluating the data in the section on Snow-Melting Heat Flux Requirement; it is usually 200 to 300 Btu/h · ft², which includes back and edge losses.

Design of the fluid heater should follow standard practice, with adjustments for the film coefficient. Consideration should be given to flue gas condensation and thermal shock in boilers because of

low fluid temperatures. Bypass flow and temperature controls may be necessary to maintain recommended boiler temperatures. Boilers should be derated for high-altitude applications.

Pump Selection

The proper pump is selected based on the (1) fluid flow rate; (2) energy requirements of the piping system; (3) specific heat of the fluid; and (4) viscosity of the fluid, particularly during a cold start-up.

Pump Selection Example

Example 3. An area of 10,000 ft² is to be designed with a snow-melting system. Using the criteria of Equation (1), a heat flux (including back and edge losses) of 250 Btu/h·ft² is selected. Thus, the total fluid heater output must be 2,500,000 Btu/h, neglecting energy distribution losses. Size the pump for the heat transfer fluid used.

Solution: For a fluid with a specific heat of 0.85 Btu/lb·°F, the flow or temperature drop must be adjusted by 15%. From Equation (18) in Chapter 12 of the 2004 *ASHRAE Handbook—HVAC Systems and Equipment*, for a 23°F temperature drop, flow would be 250 gpm. If glycol is used at 130°F, the effect on pipe pressure loss and pump performance is negligible. If the system head is 40 ft and pump efficiency 60%, pump horsepower is 4.2. Centrifugal pump design criteria may be found in Chapter 39 of the 2004 *ASHRAE Handbook—HVAC Systems and Equipment*.

Controls

The controls discussed in the section on Control (Hydronic and Electric) provide convenience and operating economy but are not required for operation. Hydronic systems require fluid temperature control for safety and for component longevity. Slab stress and temperature limits of the heat transfer fluid, pipe components, and fluid heater need to be considered. Certain nonmetallic pipe materials should not be subjected to temperatures above 140°F. If the primary control fails, a secondary fluid temperature sensor should deactivate the snow-melting system and possibly activate an alarm.

Thermal Stress

Chapman (1955) discusses the problems of thermal stress in a concrete slab. In general, thermal stress will cause no problems if the following installation and operation rules are observed:

- Minimize the temperature difference between the fluid and the slab surface by maintaining (1) close pipe spacing (see [Figure 3](#)), (2) a low temperature differential in the fluid (less than 20°F), and (3) continuous operation (if economically feasible). According to Shirakawa et al. (1985), the temperature difference between the slab surface and the heating element skin should not exceed 70°F during operation.
- Install pipe within about 2 in. of the surface.
- Use reinforcing steel designed for thermal stress if high structural loads are expected (such as on highways).

Thermal shock to the slab may occur if heated fluid is introduced from a large source of residual heat such as a storage tank, a large piping system, or another snow-melting area. The slab should be brought up to temperature by maintaining the fluid temperature differential at less than 20°F.

ELECTRIC SYSTEM DESIGN

Snow-melting systems using electricity as an energy source have heating elements in the form of (1) mineral-insulated (MI) cable, (2) self-regulating cable, (3) constant-wattage cable, or (4) high-intensity infrared heaters.

Heat Flux

The basic load calculations for electric systems are the same as presented in the section on Snow-Melting Heat Flux Requirement.

However, because electric system output is determined by the resistance installed and the voltage impressed, it cannot be altered by fluid flow rates or temperatures. Consequently, neither safety factors nor marginal capacity systems are design considerations.

Heat flux within a slab can be varied by altering the heating cable spacing to compensate for anticipated drift areas or other high-heat-loss areas. Power density should not exceed 120 W/ft² (NFPA *Standard 70*).

Electrical Equipment

Installation and design of electric snow-melting systems is governed by Article 426 of the *National Electrical Code* (NEC, or NFPA *Standard 70*), which requires that each electric snow-melting circuit (except mineral-insulated, metal-sheathed cable embedded in a non-combustible medium) be provided with a ground fault protection device. An equipment protection device (EPD) with a trip level of 30 mA should be used to reduce the likelihood of nuisance tripping.

Double-pole, single-throw switches or tandem circuit breakers should be used to open both sides of the line. The switchgear may be in any protected, convenient location. It is also advisable to include a pilot lamp on the load side of each switch so that there is a visual indication when the system is energized.

Junction boxes located at grade level are susceptible to water ingress. Weatherproof junction boxes installed above grade should be used for terminations.

The power supply conduit is run underground, outside the slab, or in a prepared base. With concrete slab, this conduit should be installed before the reinforcing mesh.

Mineral-Insulated Cable

Mineral-insulated (MI) heating cable is a magnesium oxide (MgO)-filled, die-drawn cable with one or two copper or copper alloy conductors and a seamless copper or stainless steel alloy sheath. Copper sheath versions are usually protected from salts and other chemicals by a polyvinyl chloride (PVC) or high-density polyethylene jacket.

Cable Layout. To determine the characteristics of the MI heating cable needed for a specific area, the following must be known:

- Heated area size
- Power density required
- Voltage(s) available
- Approximate cable length needed

To find the approximate MI cable length, estimate 2 ft of cable per square foot of concrete. This corresponds to 6 in. on-center spacing. Actual cable spacing will vary between 3 and 9 in. for proper power density.

Cable spacing is dictated primarily by the heat-conducting ability of the material in which the cable is embedded. Concrete has a higher heat transmission coefficient than asphalt, permitting wider cable spacing. The following is a procedure to select the proper MI heating cable:

1. Determine total power required for each heated slab.

$$W = Aw \quad (17)$$

2. Determine total resistance.

$$R = E^2/W \quad (18)$$

3. Calculate cable resistance per foot.

$$r_1 = R/L_1 \quad (19)$$

where

W = total power needed, W

A = heated area of each heated slab, ft²

w = required power density input, W/ft²

R = total resistance of cable, Ω

E = voltage available, V
 r_1 = calculated cable resistance, Ω per foot of cable
 L_1 = estimated cable length, ft
 L = actual cable length needed, ft
 r = actual cable resistance, Ω /ft
 d = cable on-center spacing, in.
 I = total current per MI cable, A

Commercially available mineral-insulated heating cables have actual resistance values (if there are two conductors, the value is the total of the two resistances) ranging from 0.0016 to 0.6 Ω /ft. Manufacturing tolerances are $\pm 10\%$ on these values. MI cables are die-drawn, with the internal conductor drawn to size indirectly by pressures transmitted through the mineral insulation.

- From manufacturers' literature, choose a cable with a resistance r closest to the calculated r_1 . Note that r is generally listed at ambient room temperature. At the specific temperature, r may drift from the listed value. It may be necessary to make a correction as described in Chapter 6 of the 2004 ASHRAE Handbook—HVAC Systems and Equipment.

- Determine the actual cable length needed to give the wattage desired.

$$L = R/r \quad (20)$$

- Determine cable spacing within the heated area.

$$d = 12A/L \quad (21)$$

For optimum performance, heating cable spacing should be within the following limits: in concrete, 3 to 9 in.; in asphalt, 3 to 6 in.

Because the manufacturing tolerance on cable length is $\pm 1\%$, and installation tolerances on cable spacing must be compatible with field conditions, it is usually necessary to adjust the installed cable as the end of the heating cable is rolled out. Cable spacing in the last several passes may have to be altered to give uniform heat distribution.

The installed cable within the heated areas follows a serpentine path originating from a corner of the heated area (Figure 5). As heat is conducted evenly from all sides of the heating cable, cables in a concrete slab can be run within half the spacing dimension of the perimeter of the heated area.

- Determine the current required for the cable.

$$I = E/R, \text{ or } I = W/E \quad (22)$$

- Choose cold-lead cable as dictated by typical design guidelines and local electrical codes (see Table 7).

Cold-Lead Cable. Every MI heating cable is factory-fabricated with a non-heat-generating cold-lead cable attached. The cold-lead cable must be long enough to reach a dry location for termination and of sufficient wire gage to comply with local and NEC standards. The NEC requires a minimum cold-lead length of 6 in. within the junction box. MI cable junction boxes must be located such that the box remains dry and at least 3 ft of cold-lead cable is available at the end for any future service (Figure 5). Preferred junction box locations are indoors; on the side of a building, utility pole, or wall; or inside a manhole on the wall. Boxes should have a hole in the bottom to drain condensation. Outdoor boxes should be completely watertight except for the condensation drain hole. Where junction boxes are mounted below grade, the cable end seals must be coated with an epoxy to prevent moisture entry. Cable end seals should extend into the junction box far enough to allow the end seal to be removed if necessary.

Although MgO, the insulation in MI cable, is hygroscopic, the only vulnerable part of the cable is the end seal. However, should

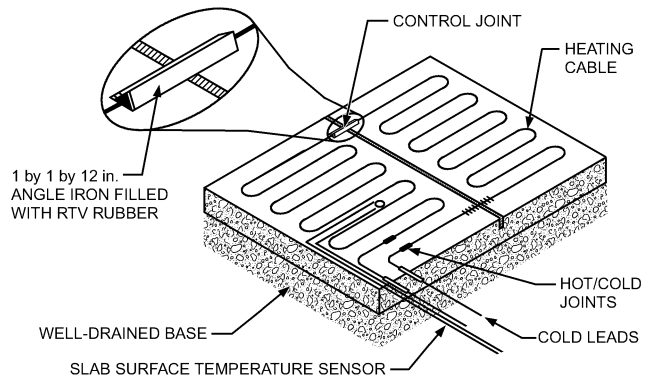

Fig. 5 Typical Mineral Insulated Heating Cable Installation in Concrete Slab

Table 7 Mineral-Insulated Cold-Lead Cables (Maximum 600 V)

Single-Conductor Cable		Two-Conductor Cable	
Current Capacity, A	American Wire Gage	Current Capacity, A	American Wire Gage
35	14	25	14/2
40	12	30	12/2
55	10	40	10/2
80	8	55	8/2
105	6	75	6/2
140	4	95	4/2
165	3		
190	2		
220	1		

Source: National Electrical Code® (NFPA Standard 70).

moisture penetrate the seal, it can easily be detected with a megohmmeter and driven out by applying a torch 2 to 3 ft from the end and working the flame toward the end.

Installation. When MI electric heating cable is installed in a concrete slab, the slab may be poured in one or two layers. In single-pour application, the cable is hooked on top of the reinforcing mesh before the pour is started. In two-layer application, the cable is laid on top of the bottom structural slab and embedded in the finish layer. For a proper bond between layers, the finish slab should be poured within 24 h of the bottom slab, and a bonding grout should be applied. The finish slab should be at least 2 in. thick. Cable should not run through expansion, control, or dummy joints (score or groove). If the cable must cross such a joint, it should cross the joint as few times as possible and be protected at the point of crossing with RTV rubber and a 1 by 1 by 12 in. angle iron as shown in Figure 5.

The cable is uncoiled from reels and laid as described in the section on Cable Layout. Prepunched copper or stainless steel spacing strips are often nailed to the lower slab for uniform spacing.

A high-density polyethylene (HDPE) or polyvinyl chloride (PVC) jacket is extruded by the manufacturer over the cable to protect from chemical damage and to protect the cable from physical damage without adding excessive thermal insulation.

If unjacketed MI cables are used, calcium chloride or other chloride additives should not be added to a concrete mix in winter because chlorides are destructive to copper. Cinder or slag fill under snow-melting slabs should also be avoided. The cold-lead cable should exit the slab underground in suitable conduits to prevent physical and chemical damage.

In asphalt slabs, the MI cable is fixed in place on top of the base pour with prepunched stainless steel strips or 6 in. by 6 in. wire mesh.

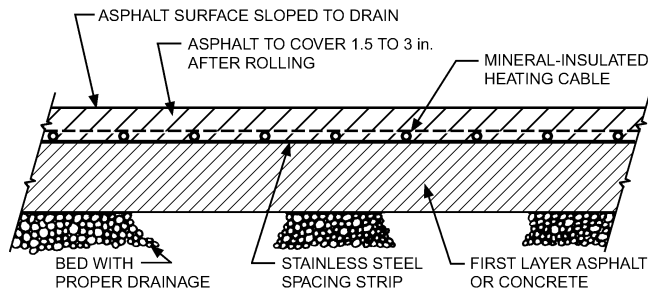

Fig. 6 Typical Section, Mineral-Insulated Heating Cable in Asphalt
(Potter 1967)

prevent them from floating when the top layer is applied. The layer of asphalt over the cable should be 1.5 to 3 in. thick (Figure 6).

Testing. Mineral-insulated heating cables should be thoroughly tested before, during, and after installation to ensure they have not been damaged either in transit or during installation.

Because MgO insulation is hygroscopic, damage to the cable sheath is easily detectable with a 500 V field megohmmeter. Cable insulation resistance should be measured on arrival of the cable. Cable with insulation resistance of less than 20 M Ω should not be used. Cable that shows a marked loss of insulation resistance after installation should be investigated for damage. Cable should also be checked for electrical continuity.

Self-Regulating Cable

Self-regulating heating cables consist of two parallel conductors embedded in a heating core made of conductive polymer. These cables automatically adjust their power output to compensate for local temperature changes. Heat is generated as electric current passes through the core between the conductors. As the slab temperature drops, the number of electrical paths increases, and more heat is produced. Conversely, as the slab temperature rises, the core has fewer electrical paths, and less heat is produced.

Power output of self-regulating cables may be specified as watts per unit length at a particular temperature or in terms of snow-melting performance at a given cable spacing. In typical slab-on-grade applications, adequate performance may be achieved with cables spaced up to 12 in. apart. Narrower cable spacings may be required to achieve the desired snow-melting performance. The parallel construction of the self-regulating cable allows it to be cut to length in the field without affecting the rated power output.

Layout. For uniform heating, the heating cable should be arranged in a serpentine pattern that covers the area with 12 in. on-center spacing (or alternative spacing determined for the design). The heating cable should not be routed closer than 4 in. to the edge of the slab, drains, anchors, or other material in the concrete.

Crossing expansion, control, or other slab joints should be avoided. Self-regulating heating cables may be crossed or overlapped as necessary. Because the cables limit power output locally, they will not burn out.

Both ends of the cable should terminate in an aboveground weatherproof junction box. Junction boxes installed at grade level are susceptible to water ingress. An allowance of heating cable should be provided at each end for termination.

The maximum circuit length published by the manufacturer for the cable type should be respected to prevent tripping of circuit breakers. Use ground fault circuit protection as required by national and local electrical codes.

Installation. Figure 7 shows a typical self-regulating cable installation. The procedure for installing a self-regulating system is as follows:

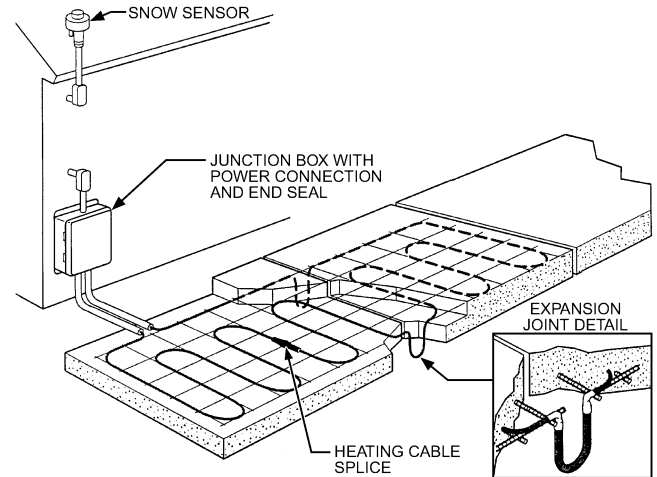

Fig. 7 Typical Self-Regulating Cable Installation

1. Hold a project coordination meeting to discuss the role of each trade and contractor. Good coordination helps ensure a successful installation.
2. Attach the heating cable to the concrete reinforcing steel or wire mesh using plastic cable ties at approximately 12 in. intervals. Reinforcing steel or wire mesh is necessary to ensure that the slab is structurally sound and that the heating cable is installed at the design depth.
3. Test the insulation resistance of the heating cable using a 2500 V dc megohmmeter connected between the braid and the two bus wires. Readings of less than 20 M Ω indicate cable jacket damage. Replace or repair damaged cable sections before the slab is poured.
4. Pour the concrete, typically in one layer. Take precautions to protect the cable during the pour. Do not strike the heating cable with sharp tools or walk on it during the pour.
5. Terminate one end of the heating cable to the power wires, and seal the other end using connection components provided by the manufacturer.

Constant-Wattage Systems

In a constant-wattage system, the resistance elements may consist of a length of copper wire or alloy with a given amount of resistance. When energized, these elements produce the required amount of heat. Witsken (1965) describes this system in further detail.

Elements are either solid-strand conductors or conductors wrapped in a spiral around a nonconducting fibrous material. Both types are covered with a layer of insulation such as PVC or silicone rubber.

The heat-generating portion of an element is the conductive core. The resistance is specified in ohms per linear foot of core. Alternatively, a manufacturer may specify the wire in terms of watts per foot of core, where the power is a function of the resistance of the core, the applied voltage, and the total length of core. As with MI cable, the power output of constant-wattage cable does not change with temperature.

Considerations in the selection of insulating materials for heating elements are power density, chemical inertness, application, and end use. Polyvinyl chloride is the least expensive insulation and is widely used because it is inert to oils, hydrocarbons, and alkalis. An outer covering of nylon is often added to increase its physical strength and to protect it from abrasion. The linear power density of embedded PVC is limited to 5 W/ft. Silicone rubber is not inert to oils or hydrocarbons. It requires an additional covering—metal braid, conduit, or fiberglass braid—for protection. This material can dissipate heat of up to 10 W/ft.

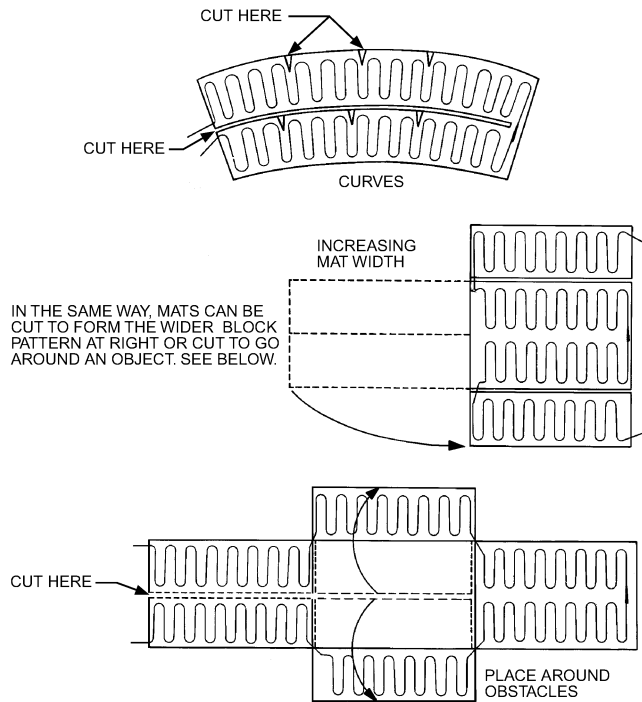

Fig. 8 Shaping Heating Mats Around Curves and Obstacles

Lead can be used to encase resistance elements insulated with glass fiber. The lead sheath is then covered with a vinyl material. Output is limited to approximately 10 W/ft by the PVC jacket.

Teflon[®] has good physical and electrical properties and can be used at temperatures up to 500°F.

Low-power-density (less than 10 W/ft) resistance wires may be attached to plastic or fiber mesh to form a mat unit. Prefabricated factory-assembled mats are available in a variety of watt densities for embedding in specified paving materials to match desired snow-melting capacities. Mats of lengths up to 60 ft are available for installation in asphalt sidewalks and driveways.

Preassembled heating mats of appropriate widths are also available for **stair steps**. Heating mats are seldom made larger than 60 ft², because larger ones are more difficult to install, both mechanically and electrically. With a series of cuts, in the plastic or fiber mesh heating mats can be tailored to follow contours of curves and fit around objects, as shown in [Figure 8](#). Extreme care should be exercised to prevent damage to the heater wire (or lead) insulation during this operation.

Mats should be installed 1.5 to 3.0 in. below the finished surface of asphalt or concrete. Installing mats deeper decreases the snow-melting efficiency. Only mats that can withstand hot-asphalt compaction should be used for asphalt paving.

Layout. Heating wires should be long enough to fit between the concrete slab dummy groove control or construction joints. Because concrete forms may be inaccurate, 2 to 4 in. of clearance should be allowed between the edge of the concrete and the heating wire. Approximately 4 in. should be allowed between adjacent heating wires at the control or construction joints.

For asphalt, the longest wire or largest heating mat that can be used on straight runs should be selected. The mats must be placed at least 12 in. in from the slab edge. Adjacent mats must not overlap. Junction boxes should be located so that each accommodates the maximum number of mats. Wiring must conform to requirements of the *NEC* (NFPA *Standard 70*). It is best to position junction boxes adjacent to or above the slab.

Installation

General

1. Check the wire or heating mats with an ohmmeter before, during, and after installation.
2. Temporarily lay the mats in position and install conduit feeders and junction boxes. Leave enough slack in the lead wires to permit temporary removal of the mats during the first pour. Carefully ground all leads using the grounding braids provided.
3. Secure all splices with approved crimped connectors or set screw clamps. Tape all of the power splices with plastic tape to make them waterproof. All junction boxes, fittings, and snug bushings must be approved for this class of application. The entire installation must be completely waterproof to ensure trouble-free operation.

In Concrete

1. Pour and finish each slab area between the expansion joints individually. Pour the base slab and rough level to within 1.5 to 2 in. of the desired finish level. Place the mats in position and check for damage.
2. Pour the top slab over the mats while the rough slab is still wet, and cover the mats to a depth of at least 1.5 in., but not more than 2 in.
3. Do not walk on the mats or strike them with shovels or other tools.
4. Except for brief testing, do not energize the mats until the concrete is completely cured.

In Asphalt

1. Pour and level the base course. If units are to be installed on an existing asphalt surface, clean it thoroughly.
2. Apply a bituminous binder course to the lower base, install the mats, and apply a second binder coating over the mats. The finish topping over the mats should be applied in a continuous pour to a depth of 1.25 to 1.5 in. *Note:* Do not dump a large mass of hot asphalt on the mats because the heat could damage the insulation.
3. Check all circuits with an ohmmeter to be sure that no damage occurred during the installation.
4. Do not energize the system until the asphalt has completely hardened.

Infrared Snow-Melting Systems

Although overhead infrared systems can be designed specifically for snow-melting and freeze protection, they are usually installed for additional features they offer. Infrared systems provide comfort heating, which is particularly useful at entrances of plants, office buildings, and hospitals or on loading docks. Infrared lamps can improve a facility's security, safety, and appearance. These additional benefits may justify the somewhat higher cost of infrared systems.

Infrared fixtures can be installed under entrance canopies, along building facades, and on freestanding poles. Approved equipment is available for recessed, surface, and pendant mounting.

Infrared Fixture Layout. The same infrared fixtures used for comfort heating installations (as described in Chapter 15 of the 2004 *ASHRAE Handbook—HVAC Systems and Equipment*) can be used for snow-melting systems. The major differences are in the orientation of the target area: whereas in comfort applications, the *vertical* surfaces of the human body constitute the target of irradiation, in snow-melting applications, a *horizontal* surface is targeted. When snow melting is the primary design concern, fixtures with narrow beam patterns confine the radiant energy within the target area for more efficient operation. Asymmetric reflector fixtures, which aim the thermal radiation primarily to one side of the fixture centerline, are often used near the periphery of the target area.

Infrared fixtures usually have a longer energy pattern parallel to the long dimension of the fixture than at right angles to it (Frier 1965). Therefore, fixtures should be mounted in a row parallel to the longest dimension of the area. If the target area is 8 ft or more in width, it is best to locate the fixtures in two or more parallel rows. This arrangement also provides better comfort heating because radiation is directed across the target area from both sides at a more favorable incident angle.

Radiation Spill. An ideal energy distribution is uniform throughout the snow-melting target area at a density equal to the design requirement. The design of heating fixture reflectors determines the percentage of the total fixture radiant output scattered outside the target area design pattern.

Even the best-controlled beam fixtures do not produce a completely sharp cutoff at the beam edges. Therefore, if uniform distribution is maintained for the full width of the area, a considerable amount of radiant energy falls outside the target area. For this reason, infrared snow-melting systems are designed so that the power density on the slab begins to decrease near the edge of the area (Frier 1964). This design procedure minimizes stray radiant energy losses.

Figure 9 shows the power densities obtained in a sample snow-melting problem (Frier 1965). The sample design average is 45 W/ft². It is apparent that the incident power density is above the design average value at the center of the target area and below average at the periphery. Figure 9 shows how the power density and distribution in the snow-melting area depend on the number, wattage, beam pattern, and mounting height of the heaters, and on their position relative to the slab (Frier 1964).

With distributions similar to the one in Figure 9, snow begins to collect at the edges of the area as the energy requirements for snow melting approach or exceed system capacity. As snowfall lessens, the snow at the edges of the area and possibly beyond is then melted if the system continues to operate.

Target Area Power Density. Theoretical target area power densities for snow melting with infrared systems are the same as those for commercial applications of constant-wattage systems except that back and edge heat losses are smaller. However, note that theoretical density values are for radiation incident on the slab surface, not that emitted from the lamps. Merely multiplying the recommended snow-melting power density by the slab area to obtain the total power input for the system does not result in good performance. Experience has shown that multiplying this product by a correction factor of 1.6 gives a more realistic figure for the total required power input. The resulting wattage compensates not only for the radiant inefficiency

involved, but also for the radiation falling outside the target area. For small areas, or when the fixture mounting height exceeds 16 ft, the multiplier can be as large as 2.0; large areas with sides of approximately equal length can have a multiplier of about 1.4.

The point-by-point method is the best way to calculate the fixture requirements for an installation. This method involves dividing the target area into 1 ft squares and adding the radiant energy from each infrared fixture incident on each square (Figure 9). The radiant energy distribution of a given infrared fixture can be obtained from the equipment manufacturer and should be followed for that fixture size and placement.

With infrared energy, the target area can be preheated to snow-melting temperatures in 20 to 30 min, unless the air temperature is well below 20°F or wind velocity is high (Frier 1965). This short warm-up time makes it unnecessary to turn on the system before snow begins to fall. The equipment can be turned on either manually or with a snow detector. A timer is sometimes used to turn the system off 4 to 6 h after snow stops falling, allowing time for the slab to dry completely.

If the snow is allowed to accumulate before the infrared system is turned on, there will be a delay in clearing the slab, as with embedded hydronic or electric systems. Because infrared energy is absorbed in the top layer of snow rather than by the slab surface, the time needed depends on snow depth and on atmospheric conditions. Generally, a system that maintains a clear slab by melting 1 in. of snow per hour as it falls requires 1 h to clear 1 in. of accumulated snow under the same conditions.

To ensure maximum efficiency, fixtures should be cleaned at least once a year, preferably at the beginning of the winter season. Other maintenance requirements are minimal.

Snow Melting in Gutters and Downspouts

Electrical heating cables are used to prevent heavy snow and ice accumulation on roof overhangs and to prevent ice dams from forming in gutters and downspouts (Lawrie 1966). Figure 10 shows a typical cable layout for protecting a roof edge and downspout. Cable for this purpose is generally rated at approximately 6 to 16 W/ft, and about 2.5 ft of wire is installed per linear foot of roof edge. One foot of heated wire per linear foot of gutter or downspout is usually adequate.

If the roof edge or gutters (or both) are heated, downspouts that carry away melted snow and ice must also be heated. A heated length of cable (weighted, if necessary) is dropped inside the downspout to the bottom, even if it is underground.

Lead wires should be spliced or plugged into the main power line in a waterproof junction box, and a ground wire should be installed from the downspout or gutter. Ground fault circuit protection is required per the NEC (NFPA Standard 70).

The system can be controlled with a moisture/temperature controller, ambient thermostat, or manual control. The moisture/temperature controller is the most energy efficient. If manual control is used, a protective thermostat should also be used to prevent system operation at ambient temperatures above 41°F.

FREEZE PROTECTION SYSTEMS

If the slab surface temperature is below 32°F, any water film present on that surface freezes. Water may be present because of accidental spillage, runoff from a nearby source, or premature shutoff of snow-melting operation after precipitation ends but before the surface dries (temperature usually drops rapidly after snow). Therefore, for cases with $A_p < 1$, if the system is shut off too soon, the remaining snow and fluid film on the surface may freeze (Adlam 1950). As previously discussed, idling keeps the slab surface from freezing by maintaining a surface temperature of at least 33.5°F and also reduces the required start-up surface heat flux for snow-melting.

INTENSITY ON PAVEMENT FROM FOUR INFRARED FIXTURES, W/ft ²														
14.7	16.0	19.75	23.7	25.5	27.5	28.2	28.0	28.2	27.5	25.5	23.7	19.75	16.0	14.7
23.7	24.8	28.7	31.7	35.7	38.2	38.5	39.4	38.5	38.2	35.7	31.7	28.7	24.8	23.7
25.7	31.7	37.5	42.7	46.4	49.4	52.2	53.0	52.2	49.4	46.4	42.7	37.5	31.7	25.7
28.2	34.3	42.8	46.7	51.2	55.7	58.5	63.0	58.5	55.7	51.2	46.7	42.8	34.3	28.2
28.2	34.3	42.8	46.7	51.2	55.7	58.5	63.0	58.5	55.7	51.2	46.7	42.8	34.3	28.2
25.7	31.7	37.5	42.7	46.4	49.4	52.2	53.0	52.2	49.4	46.4	42.7	37.5	31.7	25.7
23.7	24.8	28.7	31.7	35.7	38.2	38.5	39.4	38.5	38.2	35.7	31.7	28.7	24.8	23.7
14.7	16.0	19.75	23.7	25.5	27.5	28.2	28.0	28.2	27.5	25.5	23.7	19.75	16.0	14.7

Fig. 9 Typical Power Density Distribution for Infrared Snow-Melting System
8 by 15 ft target area, four single-element quartz lamps located 10 ft above floor (Potter 1967).

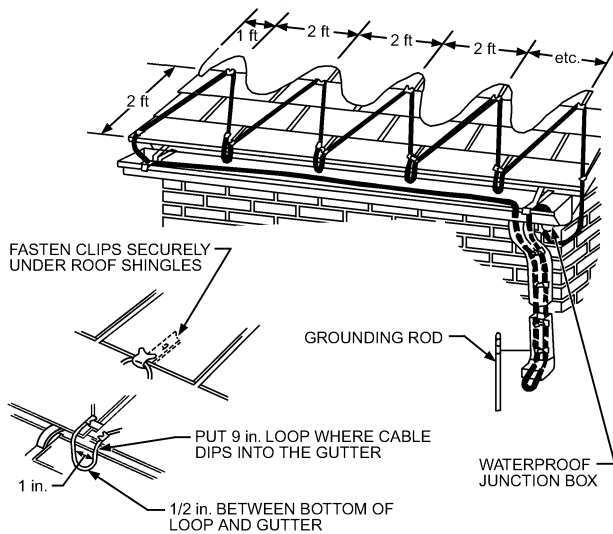

Fig. 10 Typical Insulated Wire Layout to Protect Roof Edge and Downspout

To calculate surface heat flux during idling, the surface may be assumed to be free of snow, covered with a film of water. Unless there is a constant influx of water from the vicinity, the evaporation heat flux of that film may be ignored and the surface may be assumed to be uncovered because the insulation effect of the water film is negligible. In this case, surface heat flux can be calculated by Equation (5).

The surface is free of snow; therefore, Equation (5) approximates the surface heat flux. The mean radiant temperature that appears in Equation (5) is evaluated using Equations (8), (9), and (10). The fraction F_{sc} of radiation between the surface and the clouds is equal to the cloud cover fraction in the meteorological data.

Chapman (1952) also proposed the following equation to determine the required surface heat flux for idling q_i in Btu/(h · ft²), if the mean ambient air temperature t_m during freezing is known:

$$q_i = (0.27V + 3.3)(32 - t_m) \quad (23)$$

A slab surface temperature monitor may control the freeze protection system. Whenever the slab surface temperature drops below 33°F, the system activates. However, idling the slab during the entire winter, as given in Table 3, may be too costly—and unnecessary if the main purpose is to reduce high snow-melting surface heat flux at start-up. For example, the annual energy requirement for idling is 45 times more than that for snow-melting in Chicago, $A_r = 0.5$. Therefore, a cost-effective operation may require starting the system to idle only before an anticipated snow. The lead time may be determined by the thermal mass of the slab, local meteorological conditions, idling and start-up snow-melting heat fluxes, and energy cost. Depending on local weather conditions, idling may also be started automatically when prevailing atmospheric conditions make snowfall likely.

Freeze protection systems may also be used in a variety of applications. For example, the foundation of a cold-storage warehouse may be protected from heaving by using a heated floor slab similar to a snow-melting system. The slab must be insulated at the top as well as the back and edges. Top insulation prevents the heated slab from interfering with the space-cooling process in the warehouse. Edge insulation must penetrate below the freezing line. Generally, design heat flux is taken to be between 5 and 10 Btu/(h · ft²) and the system is operated year-round.

Another freeze protection application is pipe tracing, where a pipe or conduit exposed to the atmosphere is protected against

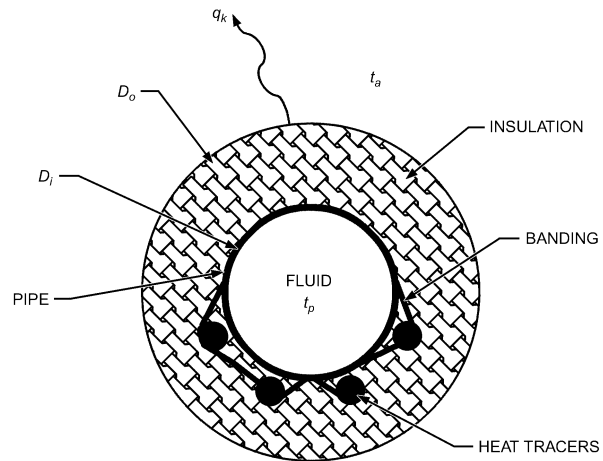

Fig. 11 Typical Heat Tracing Arrangement (Hydronic or Electric)

freezing of the fluid within. If a highly viscous fluid is transported, the desired pipe (fluid) temperature may need to be higher than the fluid-freezing temperature to maintain the viscosity required for fluid flow. Figure 11 shows a typical application in which small “tracer” pipes or electrical heating cables are banded along the lower surface of the pipe (Kenny 1999). In a hydronic tracing system, hot fluid or steam may be used. In electric systems, heating cable or mats may be used. Pipe and the tracing elements are covered with thermal insulating material such as fiberglass, polyurethane, calcium silicate, or cellular glass. Sometimes multiple insulation layers may be used. Insulating material must be protected from rain and other external conditions by a weather barrier. Pipe-tracing heat load per unit pipe length q_k is given by the following formula (IEEE 1983):

$$q_k = \frac{(t_p - t_a)}{\frac{1}{\pi D_i h_i} + \frac{\ln(D_o/D_i)}{2\pi k_1} + \frac{\ln(D_3/D_o)}{2\pi k_2} + \frac{1}{\pi D_3 h_{co}} + \frac{1}{\pi D_3 h_o}} \quad (24)$$

where

q_k = pipe tracing heat load per unit pipe length, Btu/h-ft

t_p = desired pipe temperature, °F

t_a = design ambient temperature, °F

D_i = inside diameter of inner insulation layer (and outer diameter of pipe), ft

D_o = outside diameter of inner insulation layer (and inside diameter of outer insulation layer, if present), ft

D_3 = outside diameter of outer insulation layer (if present), ft.

Otherwise, the expression $\ln(D_3/D_o)/2\pi k_2$ in Equation (24) is dropped and D_3 in the last two terms in the denominator of the same equation is replaced by D_o .

k_1 = thermal conductance of inner insulation layer, Btu/h-ft · °F (evaluated at its average operating temperature)

k_2 = thermal conductance of outer insulation layer, if present, Btu/h-ft · °F (evaluated at its average operating temperature)

h_i = thermal convection coefficient of air film between pipe and inner insulation surface, Btu/h-ft · °F.

h_{co} = thermal convection coefficient of air between outer insulation surface and weather barrier (if present), Btu/h-ft · °F.

h_o = combined surface heat transfer coefficient for radiation and convection between weather barrier, if present (otherwise, the outer insulation layer), to ambient, Btu/h-ft · °F. Values for h_o may be calculated from information in Chapter 3 of the 2005 ASHRAE Handbook—Fundamentals and Chapter 15 of the 2004 ASHRAE Handbook—HVAC Systems and Equipment.

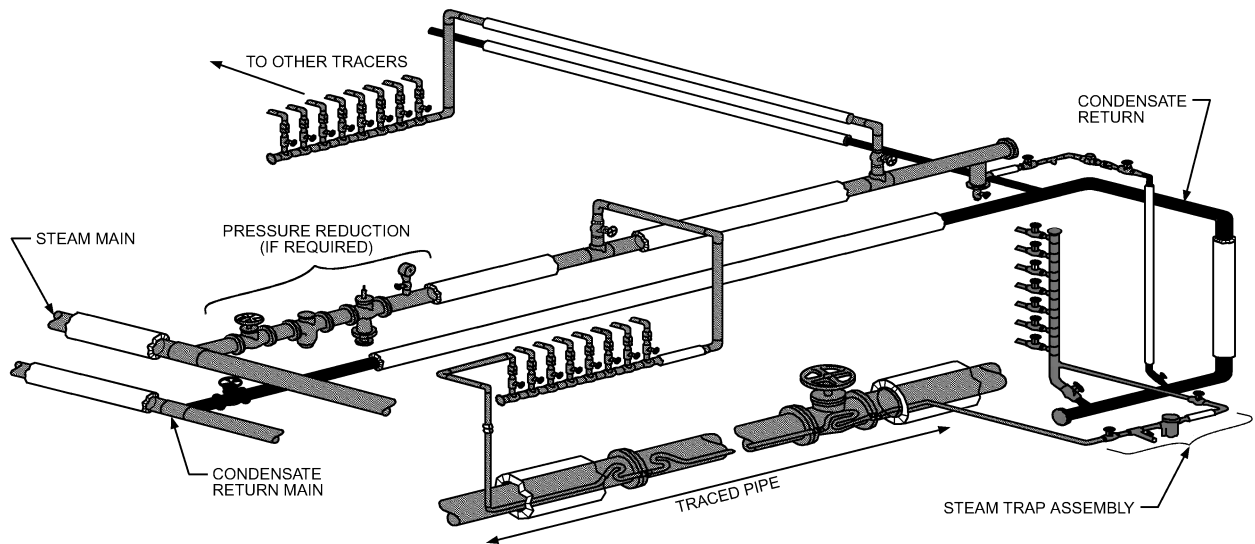

Fig. 12 Typical Pipe-Tracing System with Steam System

An appropriate pipe-tracing system is selected to satisfy q_k . For ease of product selection, some manufacturers offer design software or simple charts and graphs of heat losses for various pipe temperatures and insulation configurations. Safety factors are usually added by explicitly increasing the calculated heat load, by decreasing the design ambient temperature, or by conservative selection of k and h values. Pipe- or conduit-tracing heat loads can be more complex because of the heat sinks that penetrate the insulation surface(s); they often require a complex analysis to determine total heat loss, so a heat trace supplier should be consulted.

Steam Pipe-Tracing Systems

Steam tracing involves circulating steam in a pipe or tube that runs parallel to the pipe being traced. As the steam recondenses, it releases its latent heat and transfers it into the traced pipe. A typical steam pipe-tracing system is shown in [Figure 12](#).

Steam systems have relatively high installed costs, particularly if an appropriately sized boiler and header system is not already in place. Steam is widely used for industrial applications, and the design is familiar to pipe installers. Steam is well suited for applications that require a high heat flux, but often is not as efficient for lower-heat-flux applications such as pipe freeze protection.

Electric Pipe-Tracing Systems

Electric pipe-tracing systems involve placing (tracing) an electrical resistance wire parallel to the pipe or tube being traced. This electric heater provides heat to the pipe to balance heat loss to the lower-ambient surrounding. A typical electric system is shown in [Figure 13](#).

Types of electric heating cables include the following:

- **Self-regulating heating cables** consist of two parallel conductors embedded in a heating core made of conductive polymers. These cables automatically adjust their power output to compensate for local temperature changes. Heat is generated as electric current passes through the conductive core between the conductors. As the pipe temperature drops, the number of electrical paths increases, and more heat is produced. Power output of self-regulating heating cables is specified as watts per unit length at a particular temperature. The self-regulating feature makes the heating cables more energy efficient, because they change their power output based on the need at that point in the pipe. Because they are parallel, they can be cut to length and spliced in the field. Disadvantages are that they

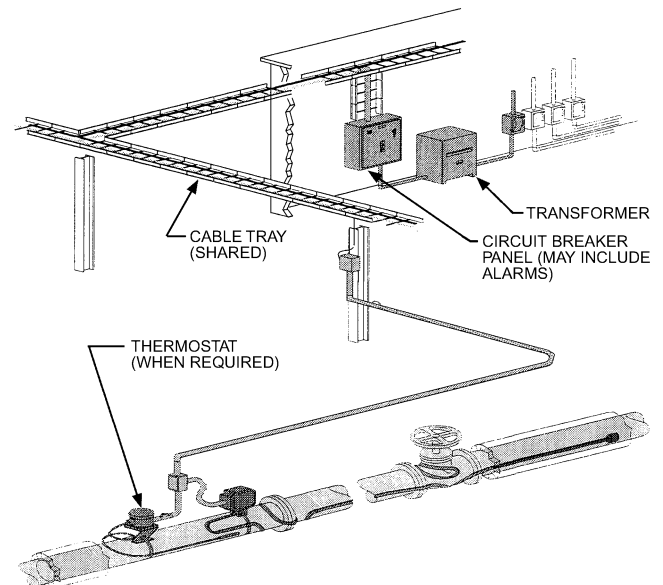

Fig. 13 Typical Pipe Tracing with Electric System

are often more expensive and have shorter maximum run lengths because of inrush current.

- **Series heating cables** are one or two copper, copper alloy, or nichrome elements surrounded by a polymer insulating jacket. Power outputs of series cables are specified in watts per unit length. These heating cables are usually inexpensive. Their main disadvantage is that the length can not be adjusted without changing the power output.
- **Mineral-insulated (MI) heating cables** are series heating cables composed of a magnesium oxide (MgO)-filled, die-drawn cable with one or two copper or copper alloy conductors and a seamless copper or stainless steel alloy sheath. Power output of an MI heating cable is specified in watts per unit length. MI heating cables are rugged and can withstand high temperatures, but are not very flexible. They generally must be ordered in the size needed; splicing in the field is craft-sensitive.
- **Zone heaters** consist of two insulated copper bus wires wrapped with a small-gauge (38 to 41 AWG) nichrome heating wire, covered

with polymer insulation. The heating wire is connected to alternate bus wires at nodes spaced 1 to 4 ft apart. Current flowing between the bus wires on the heating element generates heat. Power output of a zone heating cable is specified in watts per unit length. Zone heaters are parallel heaters, and thus can be cut to length and spliced in the field. Care must be used to prevent the thin heating wire from being damaged.

Control

The pipe-tracing system is designed to replace pipe heat loss in the worst case (at the lowest ambient temperature). Most of the time, when the temperature is above the lowest ambient temperature, the heat trace system will produce more heat than is required. To conserve energy, or to prevent the pipe from getting too warm, a control system is usually added.

Approaches to basic control include the following:

- **None.** Sometimes heat trace can be allowed to remain energized, most commonly with short lengths of self-regulating electric heat trace or in cases where the ambient temperature does not change (such as a pipe inside a cold-storage area). This is the least efficient control method from an energy usage standpoint, but the easiest to design. A slight variation on this is a manual switch to disconnect power when not needed, using a switch or circuit breaker.
- **Ambient thermostat.** This involves reading the air temperature and activating the system when the air temperature approaches freezing (often at 40°F). This ensures that the system is energized when the pipe could freeze and de-energized when it is warm. This system is often the best compromise between energy efficiency and ease of design.
- **Pipe-sensing thermostat.** This involves reading the pipe temperature and activating the heat trace system when the pipe temperature approaches freezing (often at 40°F). This is the most energy-efficient system, but is more complex to design so that the sensor reading is representative of all areas of the pipe. Always put the control sensor on the smallest pipe and at the coldest anticipated location.

REFERENCES

- Adlam, T.N. 1950. *Snow melting*. Industrial Press, New York; University Microfilms, Ann Arbor, MI.
- Brown, B. 1999. Klamath Falls geothermal district heating systems, GHC Bulletin, March 1999:5-9, Klamath, OR.
- Chapman, W.P. 1952. Design of snow melting systems. *Heating and Ventilating* (April):95 and (November):88.
- Chapman, W.P. 1955. Are thermal stresses a problem in snow melting systems? *Heating, Piping and Air Conditioning* (June):92 and (August):104.
- Chapman, W.P. 1999. A review of snow melting system design. *ASHRAE Transactions* 105(1).
- COESA. 1976. *U.S. Standard Atmosphere 1976*. U.S. Committee on Extension to the Standard Atmosphere. U.S. Government Printing Office, Washington, D.C.
- Colliver, D.G., R.S. Gates, H. Zhang, T. Burks, and K.T. Priddy. 1998. Updating the tables of design weather conditions in the *ASHRAE Handbook—Fundamentals*. ASHRAE RP-890 *Final Report*.
- Frier, J.P. 1964. Design requirements for infrared snow melting systems. *Illuminating Engineering* (October):686. Also discussion (December).

- Frier, J.P. 1965. Snow melting with infrared lamps. *Plant Engineering* (October):150.
- Gordon, P.B. 1950. Antifreeze protection for snow melting systems. *Heating, Piping and Air Conditioning Contractors National Association Official Bulletin* (February):21.
- IEEE. 1983. IEEE recommended practice for the testing, design, installation, and maintenance of electrical resistance heat-tracing for industrial applications. *IEEE Standard 515-1983*. Institute of Electrical and Electronics Engineers.
- Incropera, F.P. and D.P. DeWitt. 1996. *Introduction to heat transfer*, pp. 332-34. John Wiley & Sons, New York.
- Kenny, T.M. 1999. Effective steam tracing. *ASHRAE Journal* 41(1):42-44.
- Kilkis, I.B. 1995. An energy efficient design algorithm for snow-melting systems. *Proceedings of the International Conference ECOS '95*. Simulation and Environmental Impact of Energy Systems, ASME, NY.
- Kuehn, T.H., J.W. Ramsey, and J.L. Threlkeld. 1998. *Thermal environmental engineering*, 3rd ed. Prentice Hall, Upper Saddle River, NJ.
- Lawrie, R.J. 1966. Electric snow melting systems. *Electrical Construction and Maintenance* (March):110.
- NACE. 1978. *Basic corrosion course text* (October). National Association of Corrosion Engineers, Houston, TX.
- NCDC. 1990. *Precipitation—Hourly cooperative TD-3240 documentation manual*. National Climatic Data Center, Asheville, NC.
- NCDC. 1993. Solar and meteorological surface observation network 1961-1990 (SAMSON), Version 1.0.
- NFPA. 1996. *National electrical code®*. ANSI/NFPA Standard 70-96. National Fire Protection Association, Quincy, MA.
- Potter, W.G. 1967. Electric snow melting systems. *ASHRAE Journal* 9(10):35-44.
- Ramsey, J.W., H.D. Chiang, and R.J. Goldstein. 1982. A study of the incoming long-wave atmospheric radiation from a clear sky. *Journal of Applied Meteorology* 21:566-578.
- Ramsey, J.W., M.J. Hewett, T.H. Kuehn, and S.D. Petersen. 1999. Updated design guidelines for snow melting system. *ASHRAE Transactions* 105(1):1055-1065.
- Shirakawa, K., S. Kobayashi, S. Koyama, and M. Syuniji. 1985. Snow melting pavement with steel reinforced concrete. *Summimoto Research* 31.
- Spitler, J.D., S.J. Rees, and X. Xia. 2002. Transient analysis of snow-melting system performance. *ASHRAE Transactions* 108(2):406-425.
- Witsken, C.H. 1965. Snow melting with electric wire. *Plant Engineering* (September):129.

BIBLIOGRAPHY

- Chapman, W.P. 1955. Snow melting system hydraulics. *Air Conditioning, Heating and Ventilating* (November).
- Chapman, W.P. 1957. Calculating the heat requirements of a snow melting system. *Air Conditioning, Heating and Ventilating* (September through August).
- Chapman, W.P. and S. Katunich. 1956. Heat requirements of snow melting systems. *ASHAE Transactions* 62:359.
- Erickson, C.J. 1995. *Handbook of electrical heating for industry*. Institute of Electrical and Electronic Engineers.
- Hydronics Institute. 1994. *Snow melting calculation and installation guide*. Berkeley Heights, NJ.
- Kilkis, I.B. 1994. Design of embedded snow-melting systems: Part 1, Heat requirements—An overall assessment and recommendations. *ASHRAE Transactions* 100(1):423-433.
- Kilkis, I.B. 1994. Design of embedded snow-melting systems: Part 2, Heat transfer in the slab—A simplified model. *ASHRAE Transactions* 100(1): 434-441.
- Mohinder, L.N. 2000. *Piping handbook*, 7th ed. McGraw-Hill, New York.

[Related Commercial Resources](#)