



Standard Specification for Bell, Cast, Sound Signalling¹

This standard is issued under the fixed designation F 956; the number immediately following the designation indicates the year of original adoption or, in the case of revision, the year of last revision. A number in parentheses indicates the year of last reapproval. A superscript epsilon (ϵ) indicates an editorial change since the last revision or reapproval.

1. Scope

1.1 This specification covers cast sound-signalling bells, together with bulkhead mounting plates for the smaller bells, for use on ships, boats, and other marine craft, for compliance with the rules in the convention on the International Regulations for Preventing Collisions at Sea (commonly called Colregs).² See Appendix X1.

1.2 Bells and bulkhead mounting plate shall be sized as indicated in Section 4 (see Appendix X2).

1.3 For consistency with International Regulations, all measurements are in SI units.

2. Referenced Documents

2.1 ASTM Standards:

B 584 Specification for Copper Alloy Sand Castings for General Applications³

2.2 Other Documents:

CFR 33 Part 81–72 Implementing Rules²

CFR 33 Part 86, Subpart B, Bell or Gong²

3. Terminology

3.1 Definitions:

3.1.1 *bell n*—a hollow metal instrument that rings when struck.

3.1.2 *cast v*—to form by molding in a hollow form for shaping a liquid or plastic substance.

3.1.3 *clapper, n*—the hammer like object inside a bell.

4. Classification

4.1 Bells shall be furnished in the following sizes, based on bellmouth diameter in millimetres (see Appendix X2):

4.1.1 150 mm,

4.1.2 200 mm (2.2 kg),

4.1.3 200 mm (4.5 kg),

4.1.4 250 mm,

4.1.5 300 mm,

4.1.6 360 mm,

4.1.7 400 mm, and

4.1.8 550 mm.

4.2 Bulkhead mounting plates shall be furnished for the following bell sizes:

4.2.1 150 mm, and

4.2.2 200 mm.

5. Ordering Information

5.1 Orders for materials under this specification shall include the following information:

5.1.1 ASTM designation and year of issue.

5.1.2 Number of bells.

5.1.3 Size of bell(s) (see 4.1).

5.1.4 Additional bulkhead mounting plates (see 4.2 and 6.2.2).

5.1.5 Inscription required (see 12.1).

5.1.6 Packaging, if other than commercial (see Section 13).

6. Materials and Manufacture

6.1 Material:

6.1.1 Bell bodies, clappers, and other cast fittings and parts shall be copper alloy conforming to Specification B 584, UNS C 87200.

6.1.2 Fittings such as bolts, nuts, washers, pins, and supporting lugs shall be of copper alloy compatible with the bell castings.

6.2 Manufacture:

6.2.1 Construction shall be in accordance with Fig. 1, Fig. 2, and Fig. 3.

6.2.2 For Fig. 1 and Fig. 2, one bulkhead mounting plate shall be furnished with each bell, however, additional mounting plates may be ordered.

6.2.3 For all bells, two extra supporting nuts, washers, and acorn nuts (where used) shall be furnished.

7. Acoustic Requirements

7.1 Bells shall have full, clear, round, and farreaching tones. The sound pressure level shall not be less than 110 dB at a distance of 1 m from it.

8. Dimensions, Mass, and Permissible Variations

8.1 Dimensions and mass of bells, together with tolerances, shall conform to Fig. 1, Fig. 2, and Fig. 3.

9. Workmanship, Finish, and Appearance

9.1 Bells shall be free of cracks, burrs, sharp cutting edges, adhering sand, and other defects and blemishes affecting their

¹ This specification is under the jurisdiction of ASTM Committee F-25 on Shipbuilding and is the direct responsibility of Subcommittee F25.07 on General Requirements.

Current edition approved July 15, 1991. Published September 1991. Originally published as F 956 – 86. Last previous edition F 956 – 87.

² Available from Standardization Documents Order Desk, Bldg. 4 Section D, 700 Robbins Ave., Philadelphia, PA 19111-5094, Attn: NPODS.

³ Annual Book of ASTM Standards, Vol 02.01.

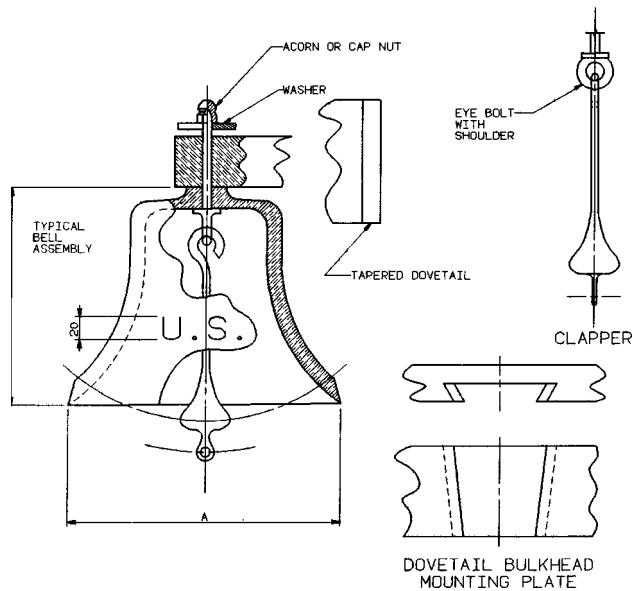

Mass and Dimensions of Bells

Bell Size, mm	Bell Mass, kg	Dimensions, mm	
		A	B
150	1.4	150	105
200	2.2	200	133
200	4.5	200	152

NOTE 1—All dimensions in millimetres.

Tolerances:

Up to 150 mm: ± 2 mm

Over 150 mm: ± 3 mm

Mass of Bell: ± 0.2 kg (± 0.3 kg for 4.5 kg bell).

Mass of Clapper: No less than 3 % of bell mass.

FIG. 1 Sizes 150 and 200

life, appearance, and serviceability.

9.2 Bell exteriors and the lower part of the interior, from the bellmouth to 10 mm above the line where the clapper strikes the bell, shall have a smooth polished finish. The “visible” part of the clapper shall have a similar finish.

10. Sampling

10.1 For orders for 1 or 2 bells of the same size, each bell shall be inspected and tested.

10.2 For orders for 3 to 10 bells of the same size, 2 bells shall be selected at random. If any one of them fails to meet the requirements, then all bells in the order shall be inspected and tested.

10.3 For orders for more than 10 bells of the same size. They shall be separated into groups of 10 (or fraction thereof) for sampling purposes.

11. Inspection and Testing

11.1 *Responsibility*—Unless otherwise specified in the order, the manufacturer is responsible for the performance of all inspection requirements specified herein. The manufacturer may utilize his own facilities or any commercial facilities acceptable to the purchaser. The purchaser reserves the right to

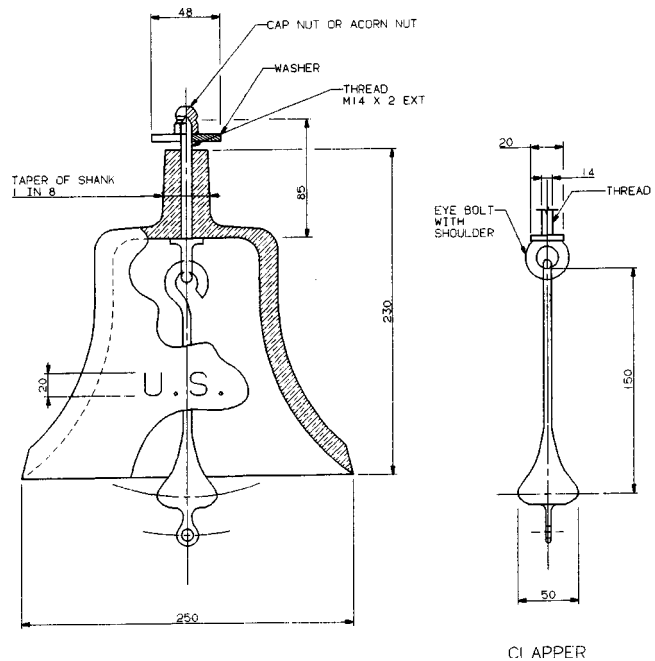

NOTE 1—All dimensions in millimetres.

Tolerances:

Up to 125 mm: ± 2 mm

Over 125 mm: ± 3 mm

Mass of bell: 9 ± 0.45 kg.

Mass of Clapper: 0.5 ± 0.05 kg.

FIG. 2 Size 250

perform any of the inspections set forth in this specification where such inspections are deemed necessary to assure that supplies conform to the prescribed requirements. Nonconforming bells shall not be offered for delivery.

11.2 Inspections:

11.2.1 The dimensions of the bell and appurtenances shall be checked to ensure that they are within the specified tolerances.

11.2.2 The bell, without bracket or mounting plate (for 150 mm and 200 mm light), and clapper shall be weighed separately to ensure that the mass is within the specified tolerance.

11.2.3 For the 150 and 200 light sizes, the brackets shall be engaged and disengaged from each of the mounting plates to ensure portability.

11.3 *Acoustic Tests*—Acoustic tests shall be conducted only for the 200 mm heavy and larger bells to check the requirements of 7.1. Each bell tested shall be supported by the yoke or eyebolt with the clapper in place. The bell shall be rung by striking the bell with the clapper, activated by a lanyard.

11.3.1 The sound, produced in accordance with Appendix X1.1, shall be measured in a space with no large sound reflecting surfaces (except the floor) that are within 10 m. The sound shall be measured using a commercial sound level meter located at a distance of 1 m and at a height above the floor equal to that of the striking point.

12. Product Marking

12.1 Owner’s inscription shall be as specified. It shall be applied either by being cast in relief (raised) or by engraving.

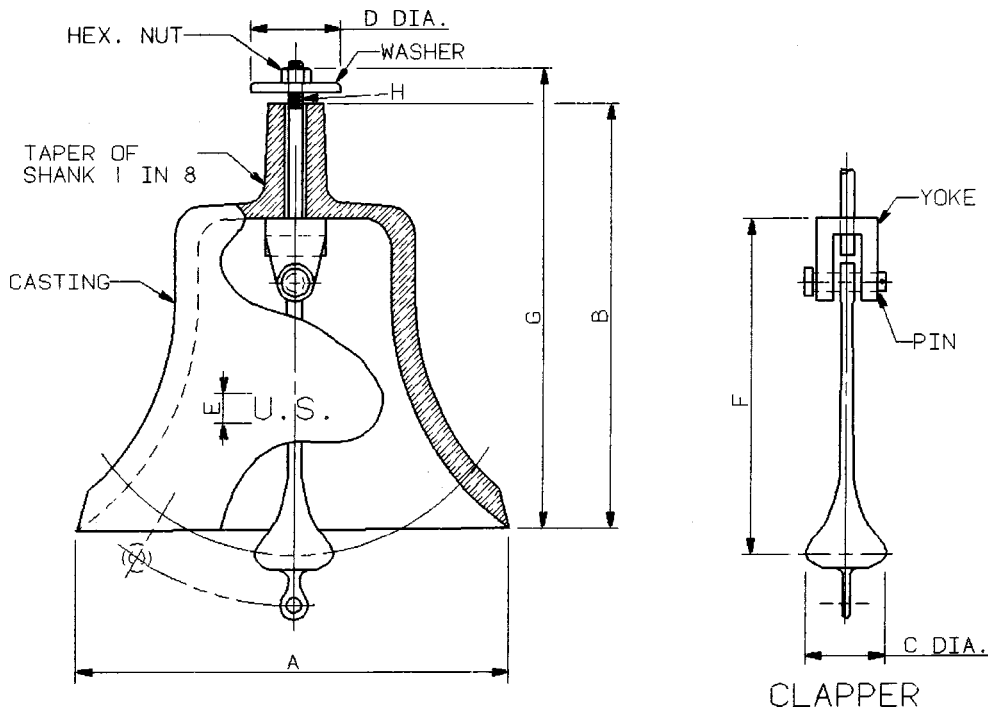

Dimensions of Bells, mm

Bell Size	A	B	C	D	E	F	G	H
300	300	270	50	65	25	208	310	M16 × 2
360	360	320	55	85	30	259	370	M20 × 2.5
400	400	350	60	100	30	291	405	M24 × 3
550	550	475	90	130	35	399	540	M24 × 3

Mass of Bells, kg

Bell Size	Bell		Clapper	
	Mass	Tolerance	Mass	Tolerance
300	14	±0.70	0.60	0.04
360	27	±1.35	0.95	0.07
400	34	±1.7	1.35	0.09
550	90	±3.6	3.40	0.18

NOTE 1—All dimensions in millimetres:

Tolerances:

- Up to 125 mm: ±2 mm
- 125 to 250 mm: ±3 mm
- 250 to 375 mm: ±5 mm
- 375 to 500 mm: ±6 mm
- Over 500 mm: ±10 mm

FIG. 3 Size 300 and Above

Size and location shall be the same as U.S. shown in Fig. 1, Fig. 2, and Fig. 3.

12.1.1 For bells intended for use on ships, boats, and other watercraft of the U.S. Army and Navy and other government agencies, the inscription shall be U.S.; size and location shall be as shown in Fig. 1, Fig. 2, and Fig. 3.

12.2 The letters ASTM and this specification number shall be engraved on the shank of each bell in figures at least 6 mm high.

12.3 The manufacturer may engrave his brand name or logo on the shank of the bell.

13. Packaging and Package Marking

13.1 No preservation is required.

13.2 Unless otherwise specified, packing shall conform to manufacturer's normal commercial practice, and in such a manner that will ensure acceptance by common carrier and afford protection against physical and mechanical damage during shipment. Shipping containers shall conform to carrier regulations as applicable to the mode of transportation.

13.3 For procurements by the U.S. Department of Defense for long-term storage or overseas shipment, the requirements of Annex A1 apply. In such case the required level of packing shall be specified.

14. Keywords

14.1 bell; bell casting; clapper; sound pressure level; sound signalling

ANNEX

(Mandatory Information)

A1. PACKING FOR DoD PROCUREMENTS

A1.1 *Applicable Documents for This Annex Only:*

A1.1.1 *Federal Specifications:*

PPP-B-576 Box, Wood, Cleated, Veneer, Paper Overlaid⁴

PPP-B-585 Boxes, Wood, Wirebound⁴

PPP-B-591 Boxes, Fiberboard, Wood-Cleated⁴

PPP-B-601 Boxes, Wood, Cleated-Plywood⁴

PPP-B-621 Boxes, Wood, Nailed and Lock Corner⁴

PPP-B-636 Box, Fiberboard⁴

PPP-B-640 Boxes, Fiberboard, Corrugated, Triple, Wall⁴

A1.1.2 *Military Standard:*

MIL-STD-129 Marking for Shipment and Storage⁴

A1.1.3 *Other Documents:*

Official Classification Committee Rules⁵

Uniform Freight Classification Rules⁵

A1.2 *Preservation*—None required.

A1.3 *Packing*—The bells shall be cushioned, blocked, or braced within the containers in a manner to prohibit movement and the clappers shall be secured or cushioned to prevent knocking. Unless otherwise specified in the order, one bell shall be packed per container. When more than one bell is required to be packed in each container, the gross mass of the wood or wood-cleated boxes shall not exceed approximately 100 kg.

A1.3.1 *Level A*

Bells shall be packed in containers conforming to any one of the following specifications at the option of the manufacturer:

<i>Specification:</i>	<i>Type or Class:</i>
PPP-B-585	Class 3
PPP-B-601	Overseas type
PPP-B-621	Class 2

A1.3.1.1 Boxes shall be closed and banded in accordance with the applicable box specification or appendix thereto.

A1.3.2 *Level B*

Bells shall be packed in boxes conforming to any of the following specifications at the option of the manufacturer:

<i>Specification:</i>	<i>Type or Class:</i>
PPP-B-576	Class 2
PPP-B-585	Class 2 use
PPP-B-591	Weather-resistant
PPP-B-601	Domestic type
PPP-B-621	Class 1
PPP-B-636	Weather-resistant
PPP-B-640	Class 2

A1.3.2.1 Box closure and banding or reinforcement shall be as specified in the box specification or appendix thereto with Method V closure applicable to PPP-B-636 boxes. The gross mass of wood or wood-cleated boxes shall not exceed 100 kg.

A1.3.3 *Level C*

Bells shall be packed as specified for Level B except that the containers may be of the non weather-resistant type or grade and Method I closure shall apply for PPP-B-636 boxes.

A1.4 *Marking*—In addition to any special marking required by the order, shipments shall be marked in accordance with MIL-STD-129.

⁴ Available from Standardization Documents Order Desk, Bldg. 4 Section D, 700 Robbins Ave., Philadelphia, PA 19111-5094, Attn: NPODS.

⁵ Uniform Classification Committee Rules available from Uniform Classification Committee, Tariff Publishing Officer, 222 S. Riverside Plaza, Chicago, IL 60606.

APPENDIXES

(Nonmandatory Information)

X1. EXCERPTS FROM U.S. COAST GUARD RULES

X1.1 For general information, the following is quoted from U.S. Coast Guard Commandant Instruction M 16672.2: Navigation Rules, International-Inland, Division II, Part D, Rule 33—Equipment for Sound Signals.

“(A) A vessel of 12 meters or more in length shall be provided with a whistle and a bell and a vessel of 100 meters or more in length, shall, in addition, be provided with a gong, the tone and sound of which cannot be confused with that of the bell. The whistle, bell and gong shall comply with the specifications in Annex III to these regulations. The bell or gong, or both, may be replaced by other equipment having the

same respective sound characteristics, provided that manual sounding of the prescribed signals shall always be possible.

(B) A vessel of less than 12 meters in length shall not be obliged to carry the sound signalling appliances prescribed in Paragraph (A) of this rule but if she does not, she shall be provided with some other means of making an efficient sound signal.

In Addition:

Division II, Part E, Annex III—Technical Detail of Sound Signalling Appliances, and 33 CFR Part 86, Subpart B:

2. *Bell or Gong:*

(A) *Intensity of Signal*—A bell or gong, or other device having similar sound characteristics shall produce a sound pressure level of not less than 110 dB at a distance of 1 meter from it.

(B) *Construction*—Bells and gongs shall be made of corrosion-resistant material and designed to give a clear tone. The diameter of the mouth of the bell shall be not less than 300 mm for vessels of 20 meters or more in length, and shall be not less than 200 mm for vessels of 12 meters or more but of less than 20 meters in length. Where practicable, a power-driven bell striker is recommended to ensure constant force but manual operation shall be possible. The mass of the striker shall be not less than 3 % of the mass of the bell.

3. *Approval*—The construction of sound signal appliances, their performance and their installation on board the vessel shall be to the satisfaction of the appropriate authority of the

state whose flag the vessel is entitled to fly.

Division II, Part E, Subpart B—Bell or Gong, Inland Rules:

86.21 *Intensity of Signal*—A bell or gong, or other device having similar sound characteristics shall produce a sound pressure level of not less than 110 dB at 1 meter.

86.23 *Construction*—Bells and gongs shall be made of corrosion-resistant material and designed to give a clear tone. The diameter of the mouth of the bell shall be not less than 300 mm for vessels of more than 20 meters in length, and shall be not less than 200 mm for vessels of 12 to 20 meters in length. The mass of the striker shall be not less than 3 % of the mass of the bell. The striker shall be capable of manual operation.

NOTE X1.1—When practicable, a power-driven bell striker is recommended to ensure constant force.”

X2. GUIDELINES FOR USE OF BELLS

X2.1 The ship’s bells covered by this specification are intended for use on the following:

X2.1.1 *Bell Type*:

X2.1.1.1 150 mm and 200 mm (2.2 kg)

Small craft and boats less than 12 m in length, quarter-deck bells and fire bells.

X2.1.1.2 200 mm (4.5 kg)—Boats 12 m to 20 m in length and ships watch and fire bell.

X2.1.1.3 250 mm—Vessels 12 m to 20 m in length, submarines less than 100 m in length.

X2.1.1.4 300 mm—Vessels 20 m to 50 m in length, submarines 100 m and over in length.

X2.1.1.5 360 mm—Vessels 50 m to 75 m in length.

X2.1.1.6 400 mm—Vessels 75 m to 150 m in length.

X2.1.1.7 550 mm—Vessels over 150 m in length.

The American Society for Testing and Materials takes no position respecting the validity of any patent rights asserted in connection with any item mentioned in this standard. Users of this standard are expressly advised that determination of the validity of any such patent rights, and the risk of infringement of such rights, are entirely their own responsibility.

This standard is subject to revision at any time by the responsible technical committee and must be reviewed every five years and if not revised, either reapproved or withdrawn. Your comments are invited either for revision of this standard or for additional standards and should be addressed to ASTM Headquarters. Your comments will receive careful consideration at a meeting of the responsible technical committee, which you may attend. If you feel that your comments have not received a fair hearing you should make your views known to the ASTM Committee on Standards, 100 Barr Harbor Drive, West Conshohocken, PA 19428.