



# Standard Specification for Bearing, Roller, Needle: Thick Outer Ring With Rollers and Cage<sup>1</sup>

This standard is issued under the fixed designation F 2246; the number immediately following the designation indicates the year of original adoption or, in the case of revision, the year of last revision. A number in parentheses indicates the year of last reapproval. A superscript epsilon ( $\epsilon$ ) indicates an editorial change since the last revision or reapproval.

## 1. Scope

1.1 This specification covers needle roller bearings having thick outer rings, with rollers and cages.

1.2 The bearings being specified are intended to be used with hardened shafts (HRC58-65; see Test Methods E 18). For use with unhardened shafts, bearings should be used in conjunction with inner bearing ring as specified in MS51962 shown as bearing assemblies in MS500072.

1.3 The use of recycled materials that meet the requirements of the applicable material specification without jeopardizing the intended use of the item is encouraged.

1.4 Bearings designed to this specification are intended for use in applications requiring high radial load with minimal angular shaft misalignment.

1.5 The values stated in inch-pound units are to be regarded as the standard. The values given in parentheses are provided for information only.

NOTE 1—This specification contains many of the requirements of MS 51961, which was originally developed and maintained by the Defense Supply Center Richmond.

## 2. Referenced Documents

### 2.1 ASTM Standards:

E 18 Test Methods for Rockwell Hardness and Rockwell Superficial Hardness of Metallic Materials<sup>2</sup>

### 2.2 ANSI Standard:<sup>3</sup>

ANSI B46.1 Surface Texture (Surface Roughness, Waviness, and Lay)

### 2.3 SAE Standards:<sup>4</sup>

SAE J-404 Chemical Compositions of SAE Alloy Steels  
SAE AMS-STD-66 Steel: Chemical Composition and Hard-  
enability

### 2.4 Military Standards:<sup>5</sup>

MIL-STD-130 Identification Marking of U.S. Military Property

MS500072 Bearing, Roller, Needle: Assembly (Thick Outer Race)

MS51962 Ring Bearing, Inner: For Needle Roller Bearing with Thick Outer Ring

### 2.5 American Bearing Manufacturers Association Standard:<sup>6</sup>

ABMA 18.1 Needle Roller Bearings Radial, Inch Design

### 2.6 International Organization for Standardization Standards:<sup>7</sup>

ISO 492 Rolling Bearings—Radial Bearings—Tolerances

ISO 3096 Rolling Bearings—Needle Rollers—Dimensions and Tolerances

ISO 5593 Rolling Bearings—Vocabulary

## 3. Terminology

3.1 *Definitions*—For definitions of terms used in this specification, refer to ISO 5593, Rolling Bearings—Vocabulary.

### 3.2 Definitions of Terms Specific to This Standard:

3.2.1 *average life ( $L_{50}$ )*—for a radial roller bearing, the number of revolutions that 50 % of a group of bearings will complete or exceed before the first evidence of fatigue developments.

3.2.1.1 *Discussion*—The average life is approximately five times the rating life.

3.2.2 *basic dynamic load rating ( $C_r$ )*—for a radial roller bearing, that calculated, constant radial load that a group of apparently identical bearings with stationary outer rings can theoretically endure for a rating life of one million revolutions of the inner ring.

3.2.2.1 *Discussion*—Since applied loading as great as the basic dynamic load rating tends to cause local plastic deformation of the rolling surfaces, it is not anticipated that such heavy loading would normally be applied.

<sup>1</sup> This specification is under the jurisdiction of ASTM Committee F34 on Rolling Element Bearings and is the direct responsibility of Subcommittee F34.06 on Aerospace.

Current edition approved May 10, 2003. Published June 2003.

<sup>2</sup> *Annual Book of ASTM Standards*, Vol 03.01.

<sup>3</sup> Available from American National Standards Institute (ANSI), 25 W. 43rd St., 4th Floor, New York, NY 10036.

<sup>4</sup> Available from Society of Automotive Engineers (SAE), 400 Commonwealth Dr., Warrendale, PA 15096-0001.

<sup>5</sup> Available from USA Information Systems, 1092 Laskin Rd. Ste. 208, Virginia Beach, VA 23451.

<sup>6</sup> Available from Techstreet, 1327 Jones Drive, Ann Arbor, MI 48105.

<sup>7</sup> Available from ANSI Washington, D.C. Headquarters, 1819 L Street, NW, 6th Floor, Washington, DC, 20036

3.2.3 *basic static load rating ( $C_{or}$ )*—for a radial roller bearing, that uniformly distributed static radial load which produces a maximum contact stress at the center of the most heavily loaded rolling element contact of 580 000 psi (4000 Mpa).

3.2.3.1 *Discussion*—For this contact stress, a total permanent deformation of roller element plus raceway occurs, which is approximately 0.0001 of the roller diameter.

3.2.4 *rating life ( $L_{10}$ )*—for a radial roller bearing, the number of revolutions that 90 % of a group of bearings will complete or exceed before the first evidence of fatigue develops.

**4. Ordering Information**

4.1 When ordering parts in accordance with this specification, specify the following:

- 4.1.1 ASTM designation number, including year of issue,
- 4.1.2 Dash number (see Table 1),
- 4.1.3 Dimensions of roller bearings, including:
  - 4.1.3.1 Bore diameter, in. (mm),
  - 4.1.3.2 Outside diameter, in. (mm),
  - 4.1.3.3 Width, in. (mm), and
  - 4.1.3.4 Radius, in. (mm),
- 4.1.4 Load rating, including basic static load rating, lb (N) and basic dynamic load rating, lb (N), and
- 4.1.5 Approximate limiting speed, rpm.

**5. Materials and Manufacture**

5.1 *Rollers*—Rollers shall be manufactured of steel, alloy, grade E50100, E51100 or E52100 in accordance with SAE AMS-STD-66 or SAE J-404.

5.2 *Rings*—Rings shall be manufactured of steel, alloy or carbon, carburizing grade 4620, 4720, 8620, 8720, or 1010-1020 in accordance with SAE AMS-STD-66 or SAE 51100 or SAE 52100 in accordance with SAE J-404.

5.3 *Cages*—Cages shall be manufactured of steel, brass, or bronze, or other material in accordance with manufacturer’s standards.

**6. Other Requirements**

6.1 *Heat Treatment:*

6.1.1 *Rollers*—Rollers shall be through hardened to Rockwell HRC58-66 in accordance with Test Methods E 18.

6.1.2 *Rings:*

6.1.2.1 Steel 4620, 4720, 8620, 8720, and 1010-1020 shall be case hardened to Rockwell HRC58-65, in accordance with Test Methods E 18. Case depth shall be 0.025 in. (0.64 mm) minimum.

6.1.2.2 Steel SAE 51100 and SAE 52100 shall be through hardened to Rockwell HRC58-65, in accordance with Test Methods E 18.

6.2 *Protective Coating:*

6.2.1 Bearings shall be furnished without plating.

6.2.2 Manufacturer shall coat bearings with rust preventive film.

6.3 *Lubrication*—Bearings shall be furnished without lubrication.

**7. Dimensions, Mass, and Permissible Variations**

7.1 Products manufactured in accordance with this specification shall meet the requirements shown in Table 1.

7.2 Bearings are intended to be installed on shafts where maximum taper does not exceed 0.0005 in. per inch (0.0005 mm per mm) of bearing width.

7.3 Bearing bore should be checked using a “go” plug gage that is 0.0001 in. (0.0025 mm) less than the minimum diameter under the needle rollers column of Table 1, and “no go” plug gage that is 0.0001 in. (0.0025 mm) larger than the maximum diameter under the needle rollers column of Table 1. The “no go” gage may enter 25 % of the roller length.

7.4 One end of the bearing must clear the maximum housing fillet radius shown in the radius column of Table 1. A minimum chamfer of 1/32 in. (0.79 mm) on the opposite end may be used in lieu of radius clearance. When ends are not identical, the marking (see Section 13) shall be applied to the end with the largest surface.

7.5 The needle roller diameter variation in each bearing shall fall within the limitations prescribed within ISO 3096 for Grade 5.

7.6 The run-out for each bearing outside diameter and raceway inside diameter shall be within the limitations prescribed in ISO 492 for the Normal Class.

7.7 Oil grooves and between one and four oil holes shall be included in accordance with manufacturer’s standard practice.

**8. Workmanship, Finish and Appearance**

8.1 *Surface Finish:*

8.1.1 *Needle Rollers*—Needle rollers shall have a maximum surface roughness, in accordance with ANSI B46.1, of 8  $\mu$ in.  $R_a$  (0.20  $\mu$ m  $R_a$ ).

8.1.2 *Rings*—The raceway surface (bore) of the outer ring shall have a maximum surface roughness, in accordance with ANSI B46.1, of 20  $\mu$ in.  $R_a$  (0.51  $\mu$ m  $R_a$ ).

**9. Rating Life of Roller Bearing**

9.1 Use the following equation to calculate rating life of roller bearing,  $L_{10}$ , in millions of revolutions, at loads other than the basic dynamic load ratings:

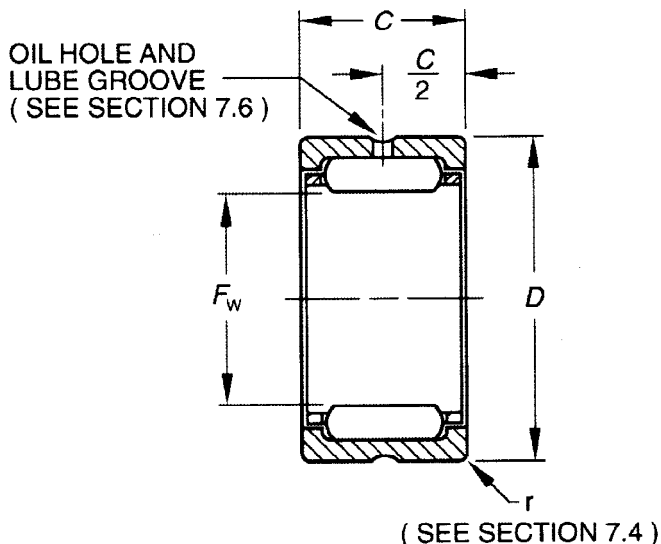

FIG. 1 Schematic Drawing—Roller Bearing

**TABLE 1 Roller Bearing Dimensions**

Dash Number	$F_w$ Bore Diameter, in.			$D$ Outside Diameter, in.			$C$ Width, in., +0.000, -0.005	Radius, in. (see 7.4)	Basic Static Load Rating, lb	Basic Dynamic Load Rating, lb	Approx. Limiting Speed, rpm
	Nom.	Min.	Max.	Nom.	Min.	Max.					
-1	5/8	0.6258	0.6267	1 1/8	1.1245	1.1250	0.750	0.025	2520	2980	30200
-2	3/4	0.7509	0.7518	1 1/4	1.2495	1.2500	0.750	0.040	2540	3180	24600
-3	3/4	0.7509	0.7518	1 1/4	1.2495	1.2500	1.000	0.040	4120	4350	24600
-4	15/16	0.8131	0.8143	1 5/16	1.3120	1.3125	0.750	0.040	2680	3210	22600
-5	7/8	0.8759	0.8768	1 3/8	1.3745	1.3750	0.750	0.040	3210	3540	20700
-6	7/8	0.8759	0.8768	1 3/8	1.3745	1.3750	1.000	0.040	4810	4860	20700
-7	15/16	0.9384	0.9393	1 7/16	1.4370	1.4375	0.750	0.040	3280	3590	20000
-8	1	1.0009	1.0018	1 1/2	1.4995	1.5000	0.750	0.040	3670	3830	19200
-9	1	1.0009	1.0018	1 1/2	1.4995	1.5000	1.000	0.040	5500	5250	19200
-10	1 1/16	1.0634	1.0643	1 9/16	1.5620	1.5625	1.000	0.040	5280	5130	17800
-11	1 1/8	1.1259	1.1268	1 5/8	1.6245	1.6250	1.000	0.040	6190	5680	15700
-12	1 1/8	1.1259	1.1268	1 5/8	1.6245	1.6250	1.250	0.040	8270	7120	15700
-13	1 3/16	1.1885	1.1894	1 11/16	1.6870	1.6875	1.000	0.040	6150	5420	14600
-14	1 1/4	1.2510	1.2519	1 3/4	1.7495	1.7500	1.000	0.040	6530	5870	14000
-15	1 1/4	1.2510	1.2519	1 3/4	1.7495	1.7500	1.250	0.040	8730	7360	14000
-16	1 5/16	1.3135	1.3144	1 13/16	1.8120	1.8125	1.000	0.040	7050	6000	13300
-17	1 5/16	1.3135	1.3144	1 13/16	1.8120	1.8125	1.250	0.040	9300	7530	13300
-18	1 3/8	1.3760	1.3769	1 7/8	1.8745	1.8750	1.000	0.040	7220	6260	12600
-19	1 3/8	1.3760	1.3769	1 7/8	1.8745	1.8750	1.250	0.040	9650	7840	12600
-20	1 7/16	1.4385	1.4394	1 15/16	1.9370	1.9375	1.000	0.060	7480	6200	12100
-21	1 1/2	1.5010	1.5019	2 1/16	2.0619	2.6025	1.000	0.060	8130	7360	11700
-22	1 1/2	1.5010	1.5019	2 1/16	2.0619	2.0625	1.250	0.060	10900	9270	11700
-23	1 9/16	1.5635	1.5644	2 1/8	2.1244	2.1250	1.250	0.060	11000	8250	11200
-24	1 5/8	1.6260	1.6269	2 3/16	2.1869	2.1875	1.000	0.060	8530	7360	10700
-25	1 5/8	1.6260	1.6269	2 3/16	2.1869	2.1875	1.250	0.060	11500	9520	10700
-26	1 11/16	1.6885	1.6895	2 1/4	2.2494	2.2500	1.250	0.060	11600	9040	10000
-27	1 3/4	1.7510	1.7520	2 5/16	2.3119	2.3125	1.000	0.060	8940	7760	9850
-28	1 3/4	1.7510	1.7520	2 5/16	2.3119	2.3125	1.250	0.060	12000	9780	9850
-29	1 7/8	1.8760	1.8770	2 7/16	2.4369	2.4375	1.250	0.060	13102	10400	9150
-30	2	2.0011	2.0021	2 9/16	2.5619	2.5625	1.250	0.060	13700	10600	8350
-31	2 1/4	2.2511	2.2521	3	2.9994	3.0000	1.500	0.060	19100	14700	7600
-32	2 1/4	2.2511	2.2521	3	2.9994	3.0000	1.750	0.060	23200	17100	7600
-33	2 1/2	2.5011	2.5021	3 1/4	3.2494	3.2500	1.500	0.080	21600	13800	6800
-34	2 1/2	2.5011	2.5021	3 1/4	3.2494	3.2500	1.750	0.080	26200	16400	6800
-35	2 3/4	2.7511	2.7521	3 1/2	3.4992	3.5000	1.500	0.080	23300	16500	6150
-36	2 3/4	2.7511	2.7521	3 1/2	3.4992	3.5000	1.730	0.080	28200	19200	6150
-37	3	3.0011	3.0023	3 3/4	3.7492	3.7500	1.500	0.080	25800	17600	5600
-38	3	3.0011	3.0023	3 3/4	3.7492	3.7500	1.750	0.080	31200	20400	5600
-39	3 1/4	3.2512	3.2524	4 1/4	4.2492	4.2500	1.750	0.080	35700	26600	5250
-40	3 1/4	3.2512	3.2524	4 1/4	4.2492	4.2500	2.000	0.080	42100	30200	5250
-41	3 1/2	3.5012	3.5024	4 1/2	4.4992	4.5000	1.750	0.080	32200	21300	4350
-42	3 1/2	3.5012	3.5024	4 1/2	4.4992	4.5000	2.000	0.080	43800	30700	4850
-43	3 3/4	3.7512	3.7524	4 3/4	4.7492	4.7500	2.000	0.100	47000	32400	4500
-44	4	4.0012	4.0024	5	4.9990	5.0000	1.750	0.100	36200	22500	4200
-45	4	4.0012	4.0024	5	4.9990	5.0000	2.000	0.100	30400	33800	4200
-46	4 1/4	4.2512	4.2526	5 1/4	5.2490	5.2500	2.000	0.100	52200	34200	3950
-47	4 1/2	4.5012	4.5026	6	5.9990	6.0000	2.000	0.100	43600	30900	3850
-48	4 1/2	4.5012	4.5026	6	5.9990	6.0000	2.250	0.100	62800	47900	3850
-49	4 1/2	4.5012	4.5026	6	5.9990	6.0000	2.500	0.100	72700	53300	3850
-50	5	5.0013	5.0027	6 1/2	6.4990	6.5000	2.000	0.100	60800	46100	3400
-51	5	5.0013	5.0027	6 1/2	6.4990	6.5000	2.500	0.100	70900	52000	3400
-52	5 1/2	5.5013	5.5027	7	6.9990	7.0000	2.500	0.100	84200	58000	3100
-53	5 1/2	5.5013	5.5027	7	6.9990	7.0000	3.000	0.100	105000	69100	3100
-54	5 3/4	5.7313	5.7327	7 1/4	7.2490	7.2500	3.000	0.120	109000	70600	2950
-55	6	6.0013	6.0027	7 1/2	7.4988	7.5000	2.500	0.120	93200	61900	2800
-56	6	6.0013	6.0027	7 1/2	7.4988	7.5000	3.000	0.120	116000	73800	2800
-57	6 1/2	6.5013	6.5029	8	7.9988	8.0000	2.500	0.120	99000	63900	2600
-58	6 1/2	6.5013	6.5029	8	7.9988	8.0000	3.000	0.120	124000	76300	2600
-59	7 1/4	7.2514	7.2530	9 1/8	9.1238	9.1250	3.000	0.120	134000	88600	2300

$$L_{10} = [C_r/P]^{10/3} \quad (1)$$

where:

$L_{10}$  = Rating life,  $10^6$  revolutions,

$C_r$  = basic dynamic load rating, lb (N), and

$P$  = equivalent radial load to which bearing is subjected, lb (N).

9.1.1 The rating life of roller bearings as calculated in Eq 1 are assumed to be operating under the following conditions:

9.1.1.1 The inner ring is rotating,

9.1.1.2 The outer ring is stationary,

9.1.1.3 The load is steady,

9.1.1.4 The revolutions per minute are uniform,

9.1.1.5 The roller bearing is thoroughly lubricated,

9.1.1.6 The maximum bearing temperature does not exceed 300°F (149°C), and

9.1.1.7 Any shaft misalignment does not exceed 0.0005 in. per inch (0.0005 mm per mm) of bearing width.

9.1.2 Eq 1 is not valid for an applied load greater than one-half the basic dynamic load rating.

## 10. Inspection

10.1 Inspection of the product shall be agreed upon between the purchaser and the supplier as part of the purchase contract.

*ASTM International takes no position respecting the validity of any patent rights asserted in connection with any item mentioned in this standard. Users of this standard are expressly advised that determination of the validity of any such patent rights, and the risk of infringement of such rights, are entirely their own responsibility.*

*This standard is subject to revision at any time by the responsible technical committee and must be reviewed every five years and if not revised, either reapproved or withdrawn. Your comments are invited either for revision of this standard or for additional standards and should be addressed to ASTM International Headquarters. Your comments will receive careful consideration at a meeting of the responsible technical committee, which you may attend. If you feel that your comments have not received a fair hearing you should make your views known to the ASTM Committee on Standards, at the address shown below.*

*This standard is copyrighted by ASTM International, 100 Barr Harbor Drive, PO Box C700, West Conshohocken, PA 19428-2959, United States. Individual reprints (single or multiple copies) of this standard may be obtained by contacting ASTM at the above address or at 610-832-9585 (phone), 610-832-9555 (fax), or service@astm.org (e-mail); or through the ASTM website (www.astm.org).*

## 11. Rejection and Rehearing

11.1 Products that fail to conform to the requirements of this specification may be rejected. Rejection should be reported to the producer or supplier promptly and in writing. In case of dissatisfaction with the results of the test, the producer or supplier may make claim for rehearing.

## 12. Certification

12.1 When specified in the purchase order or contract, the purchaser shall be furnished certification that samples representing each lot have been either tested or inspected as directed in this specification and the requirements have been met. When specified in the purchase order or contract, a report of the test results shall be furnished.

## 13. Product Marking

13.1 Marking shall consist of the part number and the manufacturer's identification in accordance with MIL-STD-130.

13.1.1 The part number shall consist of the MS51961 plus the dash number (see Table 1). Example: MS51961-1.

## 14. Keywords

14.1 cage; MS51961; needle roller; oil groove; oil hole; outer ring; radial; RBEC 1; roller bearing