



**Designation: F 606M – 98
METRIC**

Standard Test Methods for Determining the Mechanical Properties of Externally and Internally Threaded Fasteners, Washers, and Rivets [Metric]¹

This standard is issued under the fixed designation F 606M; the number immediately following the designation indicates the year of original adoption or, in the case of revision, the year of last revision. A number in parentheses indicates the year of last reapproval. A superscript epsilon (ε) indicates an editorial change since the last revision or reapproval.

This standard has been approved for use by agencies of the Department of Defense.

1. Scope

1.1 These test methods establish procedures for conducting tests to determine the mechanical properties of metric externally and internally threaded fasteners, washers, and rivets.

1.2 Property requirements and the applicable tests for their determination are specified in individual product standards. In those instances where the testing requirements are unique or at variance with these standard procedures, the product shall specify the controlling testing requirements.

1.3 These test methods describe mechanical tests for determining the following properties:

Tests	Section
For Externally Threaded Fasteners:	3
Product Hardness	3.1
Proof Load	3.2.1
Method 1, Length Measurement	3.2.3
Method 2, Yield Strength	3.2.4
Method 3, Uniform Hardness	3.2.5
Axial Tension Testing of Full Size Products	3.4
Wedge Tension Testing of Full Size Products	3.5
Tension Testing of Machined Test Specimens	3.6
Total Extension at Fracture Test	3.7
For Internally Threaded Fasteners:	4
Product Hardness	4.1
Proof Load	4.2
Cone Proof Load Test	4.3
For Washers and Direct Tension Indicators:	5
General Requirements	5.1
Through Hardened Washers	5.2
Carburized Washers	5.3
For Rivets:	6
Product Hardness	6.1
Test for Embrittlement of Metallic Coated Externally Threaded Fasteners	7

1.4 *This standard does not purport to address all of the safety concerns, if any, associated with its use. It is the responsibility of all of the users of this standard to establish appropriate safety and health practices and determine the applicability of regulatory limitations prior to use.*

NOTE 1—These test methods are the metric companion of Test Methods F 606.

¹ These test methods are under the jurisdiction of ASTM Committee F-16 on Fasteners and are the direct responsibility of Subcommittee F16.01 on Test Methods. Current edition approved Dec. 10, 1998. Published April 1999. Originally published as F 606M – 87. Last previous edition F 606M – 95b.

2. Referenced Documents

2.1 ASTM Standards:

- E 8M Test Methods for Tension Testing of Metallic Materials [Metric]²
- E 10 Test Method for Brinell Hardness of Metallic Materials²
- E 18 Test Methods for Rockwell Hardness and Rockwell Superficial Hardness of Metallic Materials²
- E 83 Practice for Verification and Classification of Extensometers²
- E 92 Test Method for Vickers Hardness of Metallic Materials²
- F 436M Specification for Hardened Steel Washers [Metric]³
- F 606 Test Methods for Determining the Mechanical Properties of Externally and Internally Threaded Fasteners, Washers, and Rivets³

3. Test Methods for Externally Threaded Fasteners

3.1 *Product Hardness*—Tests shall be conducted after the removal of any surface oxide, decarburization, plating or other coating. All readings shall be within the hardness values listed in the product specification. The average of all readings on the same part shall be considered as the product hardness. Test results shall conform to the product specification for the lot represented by the test specimens to be considered conforming. Test specimen preparation and hardness tests shall be conducted in accordance with Test Method E 18 for Rockwell tests, Test Method E 10 for Brinell tests, Test Method E 92 for Vickers tests, or Test Method E 384 for Microhardness tests. The method used is at the option of the manufacturer, with regards to the size and grade of the products.

3.1.1 *Routine Test Locations*—For testing the hardness of the finished product, the following test locations can be used:

3.1.1.1 For hex and square head bolts; test shall be conducted on the wrench flats, top of head, unthreaded shank, end of bolt or at the arbitration location.

3.1.1.2 For studs, products without parallel wrench flats and

² Annual Book of ASTM Standards, Vol 03.01.

³ Annual Book of ASTM Standards, Vol 01.08.

for head styles other than hex and square; tests shall be conducted on the unthreaded shank, end of the bolt or stud or at the arbitration location.

3.1.1.3 Stress relieved products (see 3.1.1.1 and 3.1.1.2) are measured anywhere on the surface or through the cross section. Refer to the product specification for particular test location or use the arbitration location.

3.1.1.4 The Rockwell hardness scale may be used for all product diameters; however, the Brinell hardness is limited to products over 30 mm nominal diameter.

3.1.2 *Laboratory Inspection*—After observing 3.1 and 3.1.1, a minimum of three readings shall be taken on each sample of finished product.

3.1.3 *Arbitration Test Location*—For purposes of arbitration between the purchaser and seller over reported test results, hardness tests shall be conducted at the mid-radius ($r/2$) of a transverse section through the threads taken at a distance of approximately one diameter from the point end of the bolt or one end of the stud. Four readings shall be taken approximately 90° to one another on the same plane, if product size permits. Smaller diameter products may also use the opposite parallel surface area of the bolt head end as sectioned above. (See Fig. 1). The use of Brinell hardness is limited to product sizes greater than 48 mm nominal diameter.

3.2 *Tension Tests*—It is preferred that fasteners and studs be tested full size, and it is customary, when so testing to specify a minimum ultimate load in kilonewtons (or stress in megapascals). Paragraphs 3.2 through 3.5 apply when testing externally threaded fasteners full size. Paragraph 3.6 shall apply where the individual product specifications permit the use of machined specimens. (See Test Methods E 8M.)

3.2.1 *Proof Load*—The proof-load test consists of stressing the product with a specified load that the product must withstand without measurable permanent set. Alternatives that determine the ability of a fastener to pass the proof-load test are the yield strength test and the uniform hardness test. Any of these tests may be used, but the proof-load test (3.2.3) shall be the arbitration method in case of any dispute. (See Test Methods E 8M.)

3.2.2 In both Methods 1 and 2, assemble the product in the

fixture of the tension testing machined so that six complete threads (except for heavy hex structural bolts, which shall be based on four threads) are exposed between the grips. This is obtained by freely running the nut or fixture to the thread runout of the specimen and then unscrewing the specimen six full turns. For continuous threaded fasteners, at least six full threads shall be exposed.

3.2.3 *Test Method 1, Length Measurement*—To ensure consistent and repetitive length measurements of the fastener, the threaded end and top of the bolt head shall have conical depressions made at the approximate axis or center line of the fastener. If raised or depressed markings on the head interfere with the placement of the measuring depressions, the head shall be carefully ground. The measuring instrument shall have pointed anvils which mate with the center line depressions and be capable of measuring changes in length of 0.0025 mm with an accuracy of 0.0025 mm in any 0.025 mm range. Place the fastener between the measuring anvils and rotate it approximately 1/4 turn to the left center, right then center again to assure sound seating. Zero the instrument or record indicated measurement. If using a bolt extensometer, the bolt with attached extensometer may be assembled into the tension testing machine. If not, mark the fastener so it may be placed as close as possible to the same position for the second reading. Remove and assemble the fastener into the tension testing machine as outlined in 3.4. With a test speed which shall not exceed 3 mm/min., as determined with a free-running cross head, axially load the fastener to the proof load value specified in the product specification. This load shall be maintained for a period of 10 s before releasing the load. Replace the fastener between the measuring anvils and rotate as before, stopping with the mark at the same approximate position as the first reading. The measurement shall show no permanent elongation. A tolerance of ± 0.013 mm shall be allowed (for measurement error only) between the measurement made before loading and that made after loading. Variables such as straightness, thread alignment, or measurement error could result in apparent elongation of the product when the specified proof load is initially applied. In such cases, the product may be retested using a 3 % greater load, and shall be considered

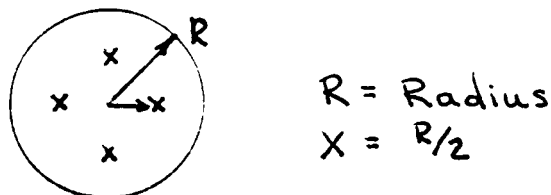
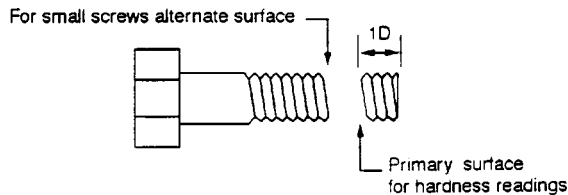

FIG. 1 Hardness Arbitration Test Location

TABLE 1 Tension Test Wedge Angles

Nominal Product Diameter, mm	Degrees	
	Fasteners ^A	Studs and Flange Fasteners
5–24	10	6
Over 24	6	4

^A Heat treated fasteners that are threaded one diameter or closer to the underside of the head, shall use a wedge angle of 6° for sizes 5 to 24 mm and 4° for sizes over 24 mm.

acceptable if there is no difference in the length measurement after this loading within a 0.013 mm measurement tolerance as outlined.

3.2.3.1 *Proof Load-Speed and Time of Loading*—When using Method 1, the speed of testing, as determined with a free-running cross head, shall not exceed 3 mm/min, and the proof load shall be maintained for a period of 10 s before releasing the load.

3.2.4 *Method 2, Yield Strength*—Assemble the product in the testing equipment as outlined in 3.4. As the load is applied, measure and record the total elongation of the product or any part of it that includes the exposed threads to produce a load-elongation diagram. Determine the load or stress at an offset equal to 0.2 % of the length of fastener occupied by six full threads as shown in Fig. 2, (except for heavy hex structural bolts, which shall be based on four threads) by the method described in 3.6.3.1.

3.2.4.1 *Method 2A, Yield Strength for Austenitic Stainless Steel and Non-ferrous Materials*—Assemble the product in the testing equipment as outlined in 3.4. As the load is applied, measure and record the total elongation of the product in order to produce a load elongation diagram. Determine the load or stress at an offset equal to 0.2 % strain, based on the length of the bolt between the holders as shown in Fig. 2, which will be subject to elongation under load, by using the method described in 3.6.3.1.

3.2.5 *Method 3, Uniform Hardness*—The fasteners shall be tested for hardness as described in 3.1, and in addition, the hardness shall also be determined in the core. The difference between the mid-radius and core hardness shall be not more than three points on a Rockwell C Scale; and both readings must be within product specification.

NOTE 2—This test is valid for fasteners up to and including 25 mm in diameter.

3.3 *Fasteners and Studs Too Short for Tension Testing*—Product lengths less than those shown in Table 1 for product 5 through 20 mm in diameter and less than 3 diameters in length

for product greater than 20 mm in diameter, or that do not have sufficient threads for proper engagement, and still leave the specified number of complete threads exposed between the grips, shall be deemed too short for tension testing, and acceptance shall be based on a hardness test performed in accordance with 3.1. If tests other than product hardness are required, their requirements should be referenced in the product specification.

3.4 *Axial Tension Testing of Full Size Products:*

3.4.1 Test fasteners in a holder with a load axially applied between the head and a nut or suitable fixture (see Fig. 2), either of which shall have sufficient thread engagement to develop the full strength of the product. Assemble the nut or fixture on the product, leaving six complete fastener threads exposed between the grips (except for heavy hex structural fastener, which shall have four threads exposed between grips).

3.4.2 Test studs by assembling one end of the threaded fixture to the thread runout. For studs having unlike threads, this shall be the end which has the finer pitch thread, or with the larger minor diameter. Likewise, assemble the other end of the stud in the threaded fixture, leaving six complete threads exposed between the grips. For continuous studs, at least six complete threads shall be exposed between the fixture ends. The maximum speed of the free running cross head shall not exceed 25 mm/min. When reporting the tensile strength of the product, calculate the thread stress area as follows:

$$A_s = 0.7854 (D - 0.9382P)^2 \tag{1}$$

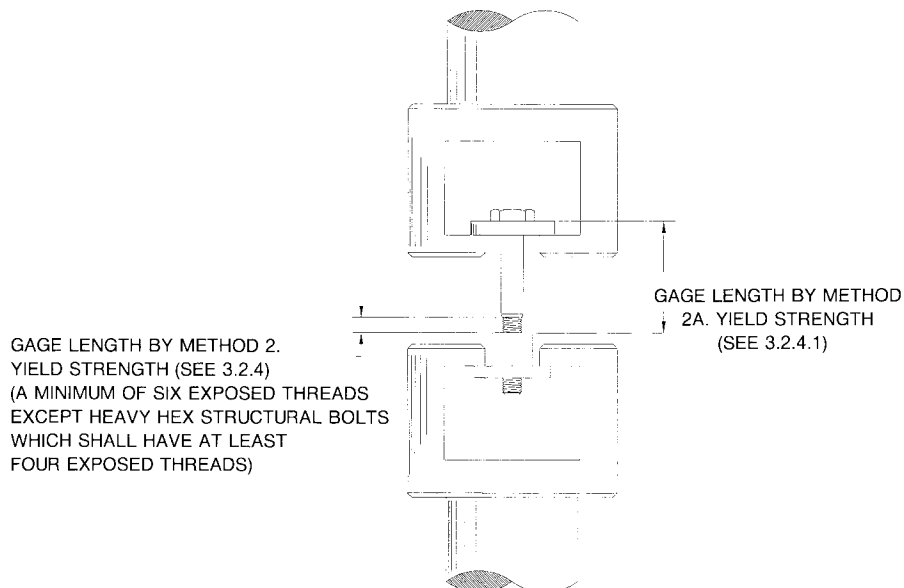

FIG. 2 Tension Testing of Full-Size Fastener (Typical Set-Up)

where:

A_s = thread stress area, mm^2 ,

D = nominal diameter of the fasteners or stud, mm, and

P = thread pitch, mm.

3.4.3 To meet the requirements of the test described in 3.4.1 and 3.4.2, the product shall support a load prior to fracture not less than the minimum tensile strength specified in the product specification for its size, property class, and thread series. In addition, fracture shall occur in the body or the threaded section with no fracture at the juncture of the body and head.

3.5 *Wedge Tension Testing of Full-Size Product*—The wedge tensile strength of a hex or square-head fastener, socket-head cap screw, (with the exception of socket button or flat countersunk head products) or stud is the tensile load that the product is capable of sustaining when stressed with a wedge under the head. The purpose of this test is to obtain the tensile strength and demonstrate the “head quality” and ductility of the product.

3.5.1 *Wedge Tension Testing of Fasteners*— Determine the ultimate load of the fastener as described in 3.4 except place a

wedge under the fastener head. When both wedge and proof load testing are required by the product specification use the proof load-tested fastener for wedge testing. The wedge shall have a minimum hardness of 45 HRC. Additionally, the wedge shall have a thickness of one half the nominal fastener diameter (measure at the thin side of the hole, Fig. 3). The wedge shall have an included angle as shown in Table 1 for the product type being tested. The hole in the wedge shall have a clearance over the nominal size of the fastener, and its edges top and bottom shall be rounded as specified in Table 2. The minimum outside dimension of the wedge shall be such that during the test no corner loading of the product head (adjacent to the wedge) shall occur. (See head orientation in Fig. 3). The bolt shall be tension tested to fracture. The fastener shall be tension tested to fracture. To meet the requirements of this test, the fastener shall support a load prior to fracture not less than the minimum tensile strength specified in the product specification for the applicable size, property class, and thread series. In addition, the fracture shall occur in the body or threaded portion with no fracture at the junction of head and shank.

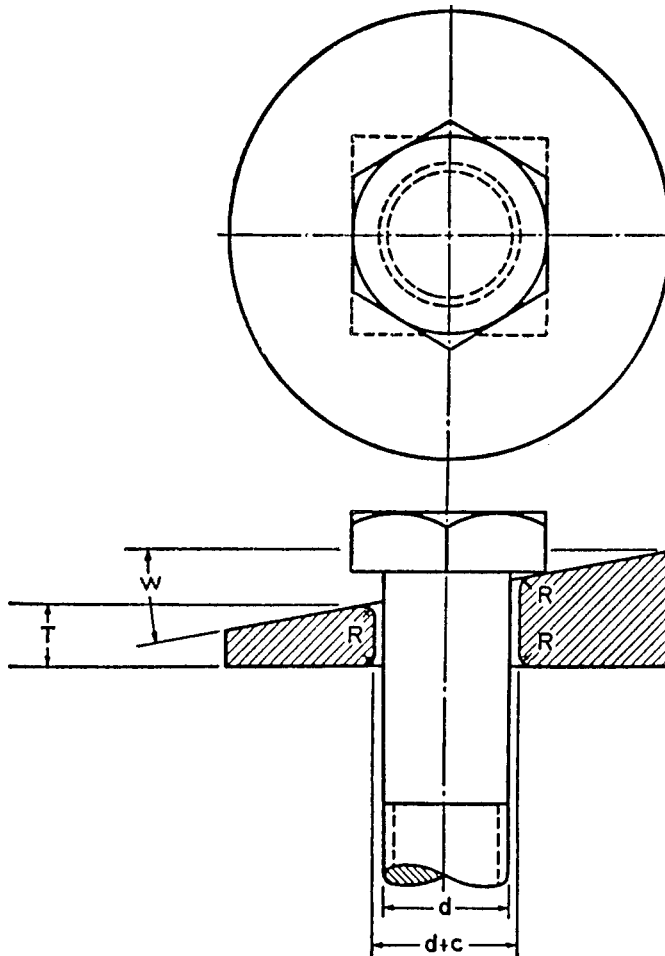

- C = clearance of hole (Table 2),
- D = diameter of fastener,
- R = radius of chamfer (Table 2)
- T = reference thickness of wedge at thin side of hole, equals one half diameter of fastener, and
- W = wedge angle (Table 1).

FIG. 3 Wedge Test Details—Fasteners

TABLE 2 Tensile Test Wedge Hole Clearance—Details

Nominal Produce Diameter, mm	Nominal Clearance in Hole, mm	Nominal Radius on Corners of Hole, mm
To 6	0.50	0.70
Over 6–12	0.80	0.80
Over 12–20	1.60	1.30
Over 20–36	3.20	1.60
Over 36	3.20	3.20

NOTE 3—Fracture at the junction of the head and shank is prohibited at any load, including those above the minimum requirements.

3.5.2 Wedge Tension Testing of Studs—When both wedge tension and proof load testing are required by the product specification, assemble one end of the same stud previously used for proof load testing in a threaded fixture to the thread runout. For studs having unlike threads, this shall be the end with the finer pitch thread or with the larger minor diameter. Assemble the other end of the stud in a threaded wedge to the runout and then unscrew six full turns, leaving six complete threads exposed between the grips (see Fig. 4). For continuous threaded studs, at least six full threads shall be exposed between the fixture ends. The angle of the wedge for the stud size and property class shall be as specified in Table 1. Assemble the stud in the testing machine and tension test to fracture, as described in 3.4. The minimum hardness of the threaded wedge shall be 45 HRC. The length of the threaded section of the wedge shall be equal to at least the diameter of the stud. To facilitate removal of the broken stud, counterbore the wedge. The thickness of the wedge at the thin side of the hole shall equal the diameter of the stud plus the depth of the counterbore. The thread in the wedge shall have Class 4H6H tolerance, except when testing studs having an interference fit thread, in which case the wedge will have to be threaded to provide a finger-free fit. The supporting fixture (Fig. 4), shall have a hole clearance over the nominal size of the stud, and

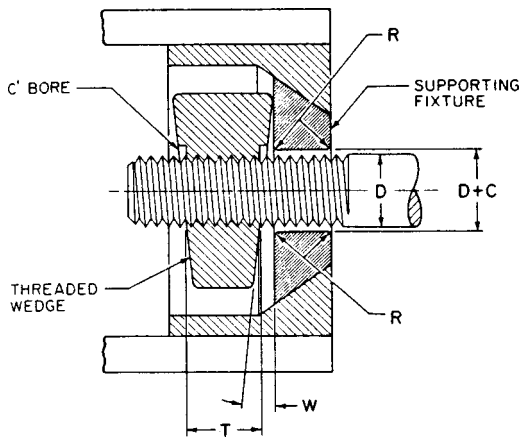

C = clearance of hole, (see Table 2)
 D = diameter of stud
 R = radius or chamfer, (see Table 2)
 T = E plus depth of counterbore
 W = wedge angle (see Table 1)
 E = length of threaded section of wedge = D

FIG. 4 Wedge Test Details—Studs

shall have its top and bottom edges rounded or chamfered to the same limits specified for the hardened wedge in Table 2. To meet the requirements of this test, the stud shall support a load prior to fracture not less than the minimum tensile strength specified in the product specification for its size, property class, and thread series. The fracture shall occur in the threaded section or in the body if the stud does not have a continuous thread.

3.6 Tension Testing of Machined Test Specimens—Where fasteners and studs cannot be tested full size, conduct tests using test specimens machined from the fastener or stud (see Test Methods E 8M).

3.6.1 Fasteners and studs shall have their shanks machined to the dimensions shown in Fig. 5. The reduction of the shank diameter of heat-treated fasteners and studs with nominal diameters larger than 16 mm shall not exceed 25 % of the original diameter of the product. Alternatively, fasteners 16 mm in diameter or larger may have their shanks machined to a test specimen with the axis of the specimen located midway between the axis and outside surface of the fastener as shown in Fig. 6. In either case, machined test specimens shall exhibit tensile strength, yield strength (or yield point), elongation, and reduction of area equal to or greater than the values of these properties specified for the product size in the applicable product specification when tested in accordance with this section.

NOTE 4—Dimensional tolerances for all test fixtures used in this test method, unless otherwise noted, shall conform to standard machining practices.

3.6.2 Determination of Tensile Properties:

3.6.2.1 Yield Point—Yield point is the first stress in a material, less than the maximum obtainable stress, at which an increase in strain occurs without an increase in stress. Yield point is intended for application only for material that may exhibit the unique characteristic of showing an increase in strain without an increase in stress. The stress-strain diagram is characterized by a sharp knee or discontinuity. Determine yield point by one of the following methods.

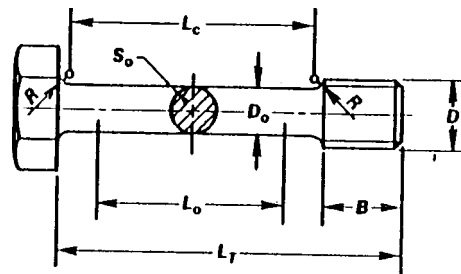

D = nominal thread diameter,
 D_o = diameter of test piece (D_o < minor diameter of thread),
 B = length of thread (B ≥ D),
 L_o = 5D_o or,

$$(5.65\sqrt{S_o})$$

 L_c = length of straight portion (L_c + D_o),
 L_T = total length of test piece (L_c + 2R + B),
 L_o = length after fracture,
 S_o = cross-sectional area, and
 R = fillet radius (R ≥ 4 mm).

FIG. 5 Tension Test Specimen with Turned-Down Shank

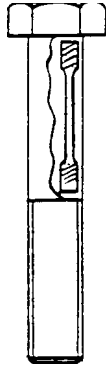

FIG. 6 Location of Standard Tension Test Specimen when Turned from Large Size Fastener

3.6.2.2 *Drop of the Beam or Halt of the Pointer Method*—In this method apply an increasing load to the specimen at a uniform rate. When a lever and poise machine is used, keep the beam in balance by running out the poise at approximately a steady rate. When the yield point of the material is reached, the increase of the load will stop, but run the poise a small amount beyond the balance position, and the beam of the machine will drop for a brief interval of time. When a machine equipped with a load-indicating dial is used, there is a halt or hesitation of the load-indicating pointer which corresponds to the drop of the beam. Record the load at the “drop of the beam” or the “halt of the pointer.” This is the yield point of the fastener or stud.

3.6.2.3 *Autographic Diagram Method*—When a sharp-kneed stress-strain diagram is obtained by an autographic device, take the stress corresponding to the top of the knee (see Fig. 7) or the stress at which the curve drops as the yield point (see Fig. 8).

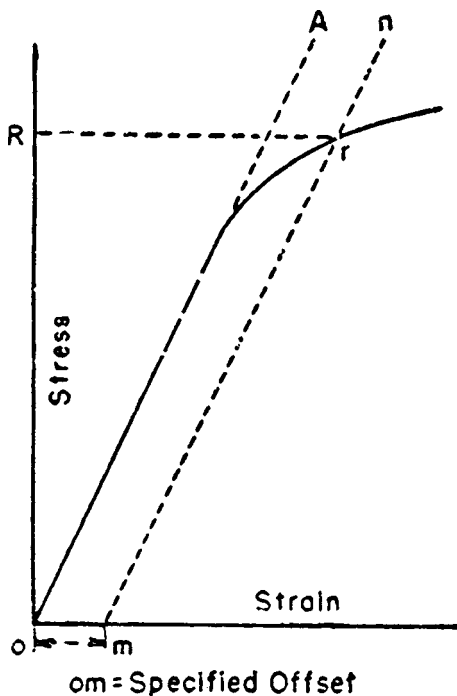

FIG. 7 Stress-Strain Diagram for Determination of Yield Strength by the Offset Method

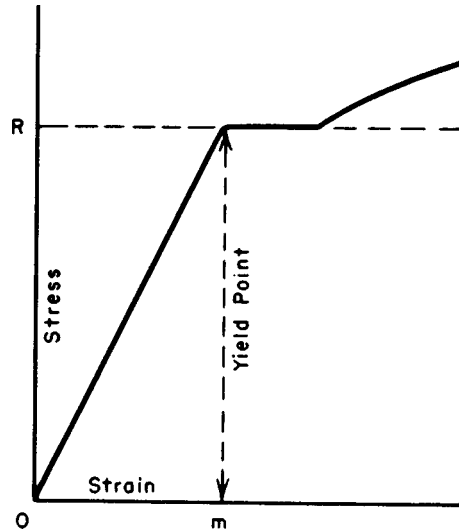

FIG. 8 Stress-Strain Diagram Showing Yield Point Corresponding with Top of Knee

3.6.2.4 *Total Extension Under Load*—When testing material for yield point and the test specimens may not exhibit a well-defined disproportionate deformation that characterizes a yield point as measured by the previous methods, a value equivalent to the yield point in its practical significance may be determined by the following method and may be recorded as yield point. Attach a Class C or better extensometer (Notes 5 and 6) to the specimen. When the load producing a specified extension (Note 7) is reached, record the stress corresponding to the load as the yield point, and remove the extensometer (see Fig. 9).

NOTE 5—Automatic devices are available that determine the load at the specified total extension without plotting a stress-strain curve. Such a device may be used if its accuracy has been demonstrated. Multiplying calipers and other such devices are acceptable for use provided their accuracy has been demonstrated as equivalent to a Class C extensometer.

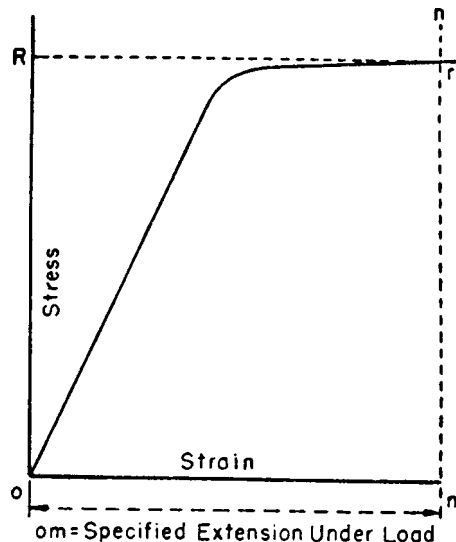

FIG. 9 Stress-Strain Diagram Showing Yield Point or Yield Strength by Extension Under Load Method

NOTE 6—Reference should be made to Practice E 83.

NOTE 7—For steel with a specified yield point not over 550 MPa an appropriate value is 0.13 mm/mm of gage length. For values above 550 MPa this method is not valid unless the limiting total extension is increased.

3.6.3 *Yield Strength*—Yield strength is the stress at which a material exhibits a specified limiting deviation from the proportionality of stress to strain. The deviation is expressed in terms of strain, percent of offset, total extension under load, etc. The determination of yield strength may be determined by one of the following methods.

3.6.3.1 *Offset Method*—To determine the yield strength by the offset method, it is necessary to secure data (autographic or numerical) from which a stress-strain diagram may be drawn. Then on the stress-strain diagram (see Fig. 7) lay off, Om , equal to the specified value of the offset, draw, mn , parallel to, OA , and thus locate r . The yield strength load, R , is the load corresponding to the highest point of the stress-strain curve before or at the intersection of mn and r . In reporting values of yield strength obtained by this method, the specified value of “offset” used should be stated in parenthesis after the term yield strength, thus:

$$\text{Yield strength (0.2 \% offset)} = 360 \text{ MPa} \quad (2)$$

In using this method, a minimum extensometer magnification of 250 to 1× is required. A Class B1 extensometer meets this requirement (see Note 6). See Note 8 for automatic devices.

3.6.3.2 *Extension Under Load Method*—For tests to determine the acceptance or rejection of material whose stress-strain characteristics are well known from previous tests of similar material in which stress-strain diagrams are plotted, the total strain corresponding to the stress at which the specified offset (see Note 9) occurs will be known within satisfactory limits. The stress on the specimen, when total strength is reached, is the value of the yield strength. The total strain can be obtained satisfactorily by use of a Class B1 extensometer (see Notes 5 and 6).

NOTE 8—Automatic devices are available that determine offset yield strength without plotting a stress-strain curve. Such devices may be used if their accuracy has been demonstrated.

NOTE 9—The appropriate magnitude of the extension under load will obviously vary with the strength range of the particular material under test. In general, the value of extension under load applicable to any material strength level may be determined from the sum of the proportional strain and the plastic strain expected at the specified yield strength. The following equation shall be used:

$$\text{Extension under load, mm/mm of gage length} = YS/E = r \quad (3)$$

where:

- YS = specified yield strength, MPa,
- E = modulus of elasticity, MPa, and
- r = limiting plastic strain, mm/mm.

3.6.4 *Tensile Strength*—Calculate the tensile strength by dividing the maximum load the specimen sustains during a tension test by the original cross-sectional area of the specimen.

3.6.5 *Elongation:*

3.6.5.1 Fit the ends of the fractured specimen together

carefully and measure the distance between the gage marks to the nearest 0.25 mm for gage lengths of 50 mm or under, and to the nearest 0.5 mm of the gage length for gage lengths over 50 mm. A percentage scale reading to 0.5 % of the gage length may be used. The elongation is the increase in length of the gage length, expressed as a percentage of the original gage length. In reporting elongation values, give both the percentage increase and the original gage length.

3.6.5.2 If any part of the fracture takes place outside the middle half of the gage length or in a punched or scribed mark with the reduced section, the elongation value obtained may not be representative of the material. If the elongation so measured meets the minimum requirements specified, no further testing is indicated, but if the elongation is less than the minimum requirements, discard the test and retest.

3.6.6 *Reduction of Area*—Fit the ends of the fractured specimen together and measure the mean diameter or the width and thickness at the smallest cross-section to the same accuracy as the original dimensions. The difference between the area thus found and the area of the original cross-section expressed as a percentage of the original area, is the reduction in area.

3.7 *Total Extension at Fracture Test:*

3.7.1 The extension at fracture (A_L) test shall be carried out on stainless steel and nonferrous products in the finished condition, with lengths equal to or in excess of those minimums listed in Table 3.

3.7.2 The products to be tested shall be measured for total length (L_1) as described in 3.7.2.1 and shown in Fig. 10.

3.7.2.1 Mark both ends of the fastener or stud using a permanent marking substance such as bluing so that measuring reference points for determining total length L_1 and L_2 are established. Using an open end caliper and steel rule or other device capable of measuring to within 0.25 mm determine the total length of the product as shown in Fig. 10.

3.7.3 The product under test shall be screwed into the threaded adapter to a depth of one diameter (see Fig. 2) and load applied axially until the product fractures. The maximum speed of the free-running cross head shall not exceed 25 mm/min.

3.7.4 After the product has been fractured in accordance with 3.7.3 the two broken pieces shall be fitted closely together and the overall length (L_2) measured (see 3.7.2.1 and Fig. 10). The total extension at fracture shall then be calculated as follows:

$$A_L = L_2 - L_1 \quad (4)$$

3.7.5 The value obtained shall equal or exceed the minimum

TABLE 3 Minimum Length of Product Requiring Tension Testing

Nominal Product Diameter, mm	Minimum Length, mm
5	12
6	14
8	20
10	25
12	30
14	35
16	40
20	45
Over 20	3 D ^A

^A The D equals the nominal diameter of the product.

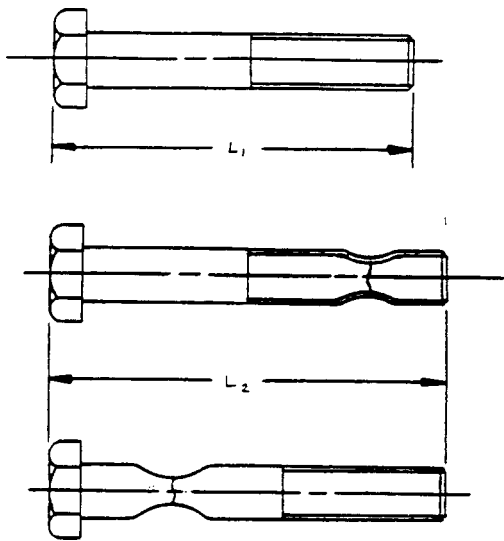

FIG. 10 Determination of Total Extension at Fracture (A_L) (Screw Product)

values shown in the applicable specification for the product and material type.

4. Test Methods for Internally Threaded Fasteners

4.1 *Product Hardness*—For routine inspection of both heat-treated and nonheat-treated nuts, hardness shall be determined on the bearing face or wrench flats after removal of any oxide, decarburization, plating, or other coating material. Rockwell or Brinell hardness shall be used at the option of the manufacturer, taking into account the size and grade of the product.

4.1.1 The preparation of test specimens and the performance of hardness tests for Rockwell and Brinell testing shall be in conformance with the requirements of Test Methods E 18 and E 10, respectively.

4.1.2 Readings when taken on the bearing face shall be halfway between the major diameter of the thread and one corner. The reported hardness shall be the average of two hardness readings located 180° apart. The readings when taken on the wrench flats shall be one third of the distance from a corner to the center of the wrench face. The reported hardness shall be the average of two readings located from opposite corners.

4.1.3 For the purpose of arbitration or for nuts too large for full size testing, where hardness alone shall determine acceptance (see 4.1.4), the following shall apply.

4.1.3.1 Sample nuts shall be sectioned laterally at approximately one half (1/2) of the nut height. Such samples need not be threaded, but shall be part of the manufacturing lot that was formed (in the case of heat-treated nuts, formed and heat-treated) with the product to be shipped. The preparation of the sample shall be in accordance with 4.1.1 above. All readings shall be conducted on a Rockwell Hardness Testing machine. For standard hex, heavy hex and square nuts, the half of the nut not to be tested may be discarded. For special nut configurations both sections shall be identified and made available to the purchaser, if specified on the purchase order or inquiry.

4.1.3.2 *Nonheat-Treated Nuts* (see Fig. 11)—Two readings shall be taken 180° apart at the core (halfway between the

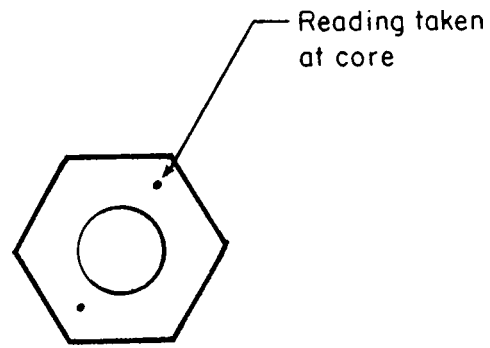

FIG. 11 Nonheat-Treated Nut

major diameter if threaded, or blank hole if not threaded) and a corner of the nut. The reported hardness shall be the average of the two readings, and in addition both readings shall be within the hardness values listed in the product specification.

4.1.3.3 *Heat-Treated Nuts* (See Fig. 12)—Two sets of three readings 180° apart shall be taken. The three readings shall be taken across the section of the nut at the following positions:

Position 1—As close to the major diameter, as possible, if threaded, or hole side wall if the nut is blank, but no closer than 2½ times the indent diameter.

Position 2—At the core (halfway between the major diameter, if threaded, or hole side wall, if blank) and a corner of the nut.

Position 3—As close to the corner of the nut as possible, but no closer than 2½ times the indent diameter.

4.1.3.4 The reported hardness shall be the average of all six readings. In addition all readings shall be within hardness values listed in the product specification.

4.1.4 Nuts exhibiting a proofload in excess of 160 000 lb may be considered, at the option of the manufacturer, as too large for full-size testing. Full-size testing is recommended whenever possible.

4.1.5 For nuts on which hardness and proof load tests are performed, acceptance based on proof load requirements shall take precedence in the event of controversy with hardness tests.

4.2 *Proof Load Test*—Assemble the nut to be tested on a hardened threaded mandrel 4.2.2) or a test bolt (4.2.1) as shown in Fig. 13(a) Tension Method or Fig. 13(b) Compression Method. The hardened test mandrel and the tension method shown in Fig. 13(a) shall be mandatory as a reference if arbitration is necessary. Apply the specified proof load for the nut against the nut. The nut shall resist this load without stripping or rupture, and shall be removable from the test bolt or mandrel by the fingers after the load is released. Occasionally it may be necessary to use a manual wrench or other means to start the nut in motion. Use of such means is permissible,

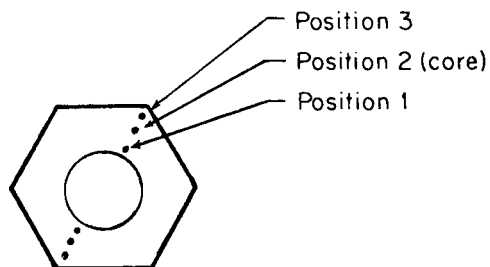
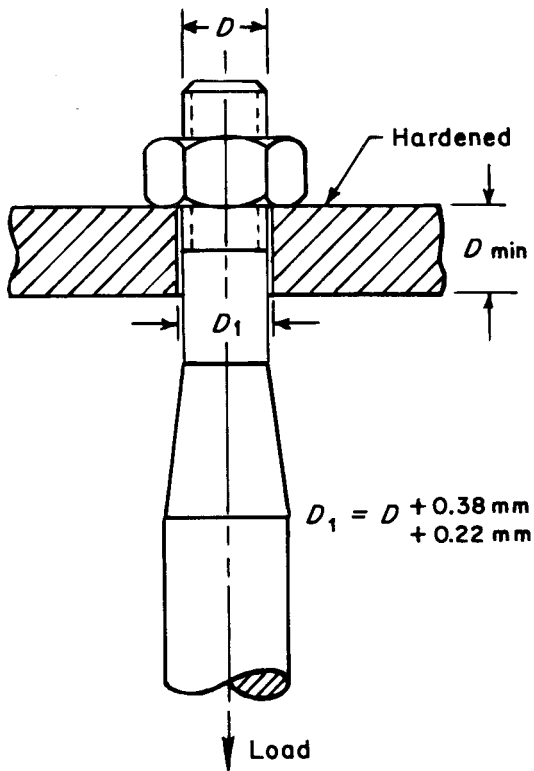
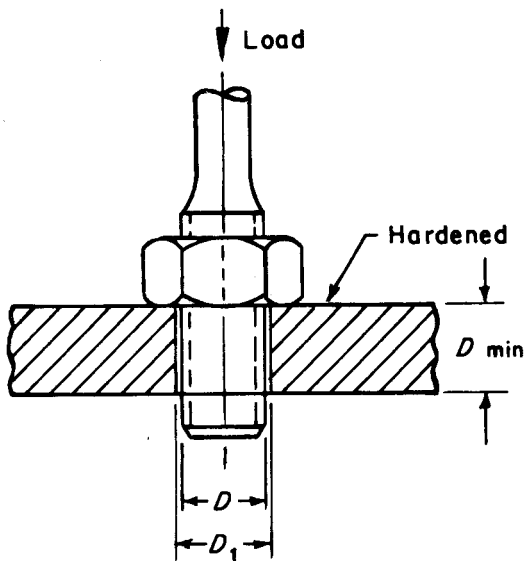

FIG. 12 Heat-Treated Nut



(a) Tension Method



(b) Compression Method

FIG. 13 Proof Load Testing—Nuts

provided the nut is removable by the fingers following the initial loosening of not more than one-half turn of the nut. If the threads of the mandrel or test bolt are damaged during the test, discard the test.

4.2.1 The test fastener shall be appropriate to the standard specified for the nut being tested and shall have a yield strength in excess of the specified proof load of the nut being tested.

4.2.2 Mandrels shall have a hardness of 45 HRC minimum; the mandrel shall have threads conforming to the same standards as those specified for the nut being tested, except that the maximum major diameter shall be the specified minimum major diameter for class 4H6H threads and the maximum major diameter plus 0.25 times the major diameter tolerance of class 4H6H threads.

4.2.3 The proof load shall be determined at a free running cross head not exceeding 25 mm/minute and shall be held at load for 10_s minimum.

4.3 *Cone Proof Load Tests*—Perform this test using a conical washer and threaded mandrel (as illustrated in Fig. 14) to determine the influence of surface discontinuities (forging cracks and seams) on the load-carrying ability of hardened steel nuts through 36 mm in diameter by introducing a simultaneous dilation and stripping action of the nut. The mandrel shall conform to the requirements of 4.2.2. The conical washer shall have a hardness of 57 HRC minimum and a hole diameter of the mandrel +0.05 mm and -0.00 mm. The contact point of the cone shall be sharp for nut sizes 12 mm or less. For sizes greater than 12 mm the point shall be flat and 0.38 mm ± 0.03 mm in width. Assemble the nut and the conical washer on the mandrel, and apply the cone proof load for the nut against the nut. The speed of testing as determined with a free-running cross head shall be a maximum of 3 mm/mm. Apply the proof load for 10 s. The proof load of the nut is computed as follows:

$$CPL = (1 - 0.012D)f \times A_s \times 0.001 \quad (5)$$

where:

- CPL = cone proof load, kN,
- D = nominal diameter of nut, mm,
- f = specified proof stress of nut, MPa,
- A_s = tensile stress area of nut, mm²,
= 0.7854 [D - (0.9382P)]², and
- P = thread pitch, mm.

To meet the requirements of the cone proof load test, the nut shall support its specified cone proof load without stripping or rupture.

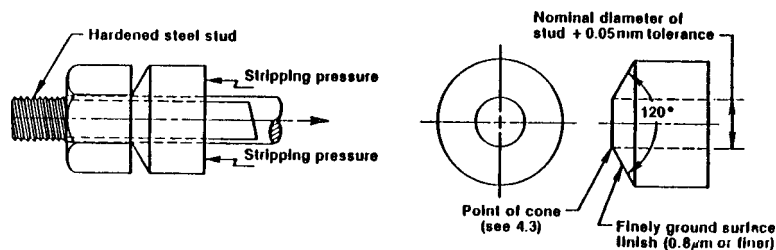

FIG. 14 Cone-Proof Test

5. Test Methods for Washers and Direct Tension Indicators

5.1 General Requirements:

5.1.1 All tests shall be conducted on a Rockwell hardness tester.

5.1.2 Use of a 6 mm (1/4in.) or smaller spot anvil shall be used for hardness testing of washers and direct tension indicators.

5.1.3 Readings are not to be taken on or near product markings.

5.1.4 Preparation of test specimens and the performance of hardness tests shall be performed in accordance with Test Methods E 18.

5.1.5 For arbitration purposes, a minimum of two readings 180° apart on at least one face shall be taken. (See Fig. 15).

5.1.6 All readings shall be within the hardness values listed in the product specification, and the average of all readings shall be considered as the hardness of the product.

5.1.7 An initial reading may be used to establish that the hardness testing equipment is properly set up and that the correct scale is being used. Such readings are not used to determine conformance.

5.2 Through Hardened Washers:

5.2.1 *Surface Hardness*—Take hardness readings on a smooth flat portion of the washer, prepared by light grinding or polishing as necessary.

5.2.2 *Core Hardness*—Take hardness readings on a smooth flat portion of the washer, prepared by light grinding or polishing such that readings are taken at a minimum depth of 0.38 mm (0.015 in.) from the original surface.

5.3 Carburized Washers:

5.3.1 *Surface Hardness*—Take hardness readings on a smooth flat portion of the washer, using a method which prevents penetration into the core material.

5.3.2 *Core Hardness*—Take hardness readings on a smooth flat portion of the washer, prepared by light grinding or polishing such that readings are taken at a depth greater than the depth of case.

5.3.3 *Depth of Case*—Measurements of case depth shall be taken at a cross section through the rim of the washer, having

been ground and etched to define the case area.

5.4 Stainless Steel and Nonferrous Washers:

5.4.1 *Surface Hardness*—Take hardness readings on a smooth flat portion of the washer.

5.4.2 *Core Hardness*—Take hardness readings on a smooth flat portion of the washer, prepared by light grinding or polishing such that readings are taken at a minimum depth of 0.38 mm (0.015 in.) from the original surface.

5.5 Direct Tension Indicators:

5.5.1 *Surface Hardness*—Take hardness readings on a smooth flat portion of the DTI, at a point approximately midway between the protrusion (top side) or pocket (bottom side) and the outside diameter. Prepare the DTI by light grinding or polishing as necessary.

5.5.2 *Core Hardness*—Take hardness readings on a smooth flat portion of the DTI, at a point approximately midway between the protrusion (top side) or pocket (bottom side) and the outside diameter. Prepare the DTI by light grinding or polishing such that readings are taken at a minimum depth of 0.38 mm (0.015 in.) from the original surface.

6. Rivets

6.1 *Product Hardness*—Determine hardness at the mid-radius of a transverse section of the product taken at a distance of one diameter from the point end of the rivet. Use either Brinell or Rockwell hardness tests, and measure as described in 3.1.

7. Test for Embrittlement of Metallic Coated Externally Threaded Fasteners

7.1 This is one test method for determining if embrittlement exists in a metallic coated externally threaded fastener covered by the product specifications of ASTM Committee F-16.

7.2 The test fastener shall be installed in a test fixture (see Note 1 in Fig. 16) with the head positioned against the wedge, assembled with a nut, and tensioned (by means of the nut only) by any means capable of measuring tensile load. The torque method described in 7.3 is one such method. The test samples shall be tensioned to 75 % of their specified minimum ultimate tensile strength. For studs with different thread pitches on

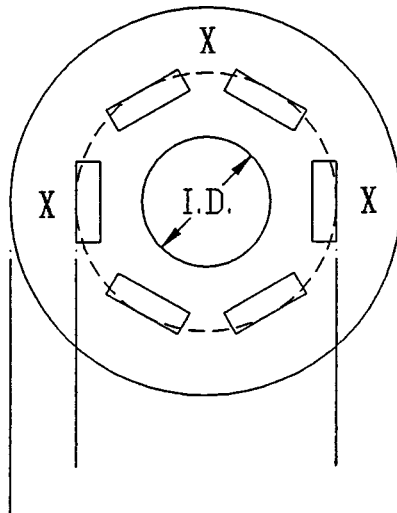
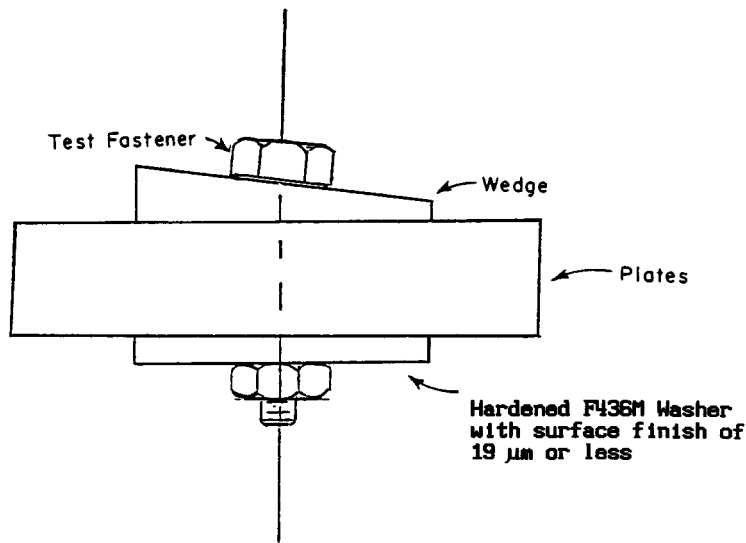

FIG. 15 Typical Hardness Reading Locations

ASTM F 606M



NOTE 1—For expedience sake the test fixture shown above reflects a single bolt under load. It should be noted, however, that test fixtures with multiple test locations are acceptable.

NOTE 2—Work is continuing on this test method and revisions are anticipated. Additional caution should be taken when applying this test procedure. The heads of embrittled fasteners may suddenly break off and become flying projectiles capable of causing serious injury or blinding.

FIG. 16 Test Fixture

either end, the finer thread pitch end shall be assembled with a nut and tested as the head end of the fastener.

7.2.1 The assembly shall remain in this tightened state for not less than 48 h, after which the test fastener shall be visually examined for embrittlement-induced failure, such as missing head.

7.2.2 The joint shall then be disassembled and the test fastener visually examined using a minimum of 20 power magnification for evidence of embrittlement failure, such as transverse cracks in the shank, threads or at the junction of head to shank.

7.2.3 For disassembly, if the torque method of tightening is used, torque shall be applied in the ON direction until the nut rotates a noticeable amount. The retightening torque with the nut in motion shall be measured and shall be no less than 90 % of the initial tightening torque.

7.2.4 If a direct tension method of tightening is used, then the loss of clamping strength (in kilograms) over the test period shall be no more than 10 % of the initial clamping load.

7.3 The test fixture shall comprise a hardened wedge (see 7.3.1), a plate(s) (see 7.3.2), and a hardened washer (see 7.3.3). (See Fig. 16).

7.3.1 The wedge shall have an angle as specified in Table 4. Other dimensions and properties shall be in conformance with hardened wedges described in 3.5.1.

7.3.2 The plate(s) shall be steel and have a thickness such that, after installation and tightening, a minimum of three full threads of the test fastener will be in the grip. The hole in the plate(s) shall be as close to the major diameter of the fastener

TABLE 4 Test for Embrittlement Wedge Angles, Degrees

Nominal Size of Fastener, dia	Studs and Fasteners with Unthreaded Lengths, Less Than 2 dia	Fasteners with Unthreaded Lengths, 2 dia and Longer
5 to 20 mm	4	6
Over 20 mm	0	4

being tested as practical but not greater than the hole in the hardened washer (see 7.2.3).

7.3.3 The hardened washer shall be in conformance with Specification F 436M.

7.4 If the torque method of tightening is used, the tightening torque shall be determined using a load-measuring device capable of measuring the actual tension induced in a fastener as the fastener is tightened. Three fasteners from the test lot shall be selected at random. Each shall be assembled into the load-measuring device, mated with a nut, and the nut tightened until a load equal to 75 % of the specified minimum ultimate tensile strength of the fastener is induced. The torque required to induce this load shall be measured and the arithmetic average of the three measured torques shall be the tightening torque. The surface against which the nut is torqued should be similar in hardness and finish to that of the test fixture (see Fig. 16) and use of a hardened washer (see 7.3.3) is recommended.

7.5 To meet the requirements of this test the fastener shall show no evidence of embrittlement failure when visually examined and the retightening torque shall not be less than 90 % of the initial tightening torque.

 **F 606M**

The American Society for Testing and Materials takes no position respecting the validity of any patent rights asserted in connection with any item mentioned in this standard. Users of this standard are expressly advised that determination of the validity of any such patent rights, and the risk of infringement of such rights, are entirely their own responsibility.

This standard is subject to revision at any time by the responsible technical committee and must be reviewed every five years and if not revised, either reapproved or withdrawn. Your comments are invited either for revision of this standard or for additional standards and should be addressed to ASTM Headquarters. Your comments will receive careful consideration at a meeting of the responsible technical committee, which you may attend. If you feel that your comments have not received a fair hearing you should make your views known to the ASTM Committee on Standards, at the address shown below.

This standard is copyrighted by ASTM, 100 Barr Harbor Drive, PO Box C700, West Conshohocken, PA 19428-2959, United States. Individual reprints (single or multiple copies) of this standard may be obtained by contacting ASTM at the above address or at 610-832-9585 (phone), 610-832-9555 (fax), or service@astm.org (e-mail); or through the ASTM website (www.astm.org).