



Designation: **F 812/F 812M – 023**

Standard Specification for Surface Discontinuities of Nuts, Inch and Metric Series¹

This standard is issued under the fixed designation F 812/F 812M; the number immediately following the designation indicates the year of original adoption or, in the case of revision, the year of last revision. A number in parentheses indicates the year of last reappraisal. A superscript epsilon (ϵ) indicates an editorial change since the last revision or reappraisal.

This standard has been approved for use by agencies of the Department of Defense.

1. Scope

1.1 This specification establishes allowable limits for the various types of surface discontinuities that may occur during the manufacture and processing of metric-series nuts with nominal diameters 5 mm and larger and inch-series nuts with nominal diameters $\frac{1}{4}$ in. and larger.

1.2 The values stated in either SI (metric) or inch-pound units are to be regarded separately as standard. The values stated in each system are not exact equivalents; therefore, each system must be used independently of the other. Combining values from the two systems may result in nonconformance with the specification.

1.3 When the engineering requirements of the application necessitate control of surface discontinuities on nuts, the purchaser shall specify conformance to this ASTM specification in the original inquiry and purchase order.

1.3.1 When the engineering requirements of the application necessitate that surface discontinuities on nuts be controlled within limits closer than those specified in this specification, the purchaser shall specify the applicable limits in the original inquiry and purchase order.

1.4 The allowable limits established in this specification for metric nuts, with nominal diameters 5 to 24 mm inclusive, are essentially identical with requirements given in ISO/DIS 6157/II. There are no ISO standards for surface discontinuities on metric-series nuts with nominal diameters larger than 24 mm or on any inch-series nuts.

1.5 The following precautionary caveat pertains only to the test method portion, Section 6, 7, of this specification: *This standard does not purport to address all of the safety concerns, if any, associated with its use. It is the responsibility of the user of this standard to establish appropriate safety and health practices and determine the applicability of regulatory limitations prior to use.*

2. Referenced Documents

2.1 *ASTM Standards:*

¹ This specification is under the jurisdiction of ASTM Committee F16 on Fasteners and is the direct responsibility of Subcommittee F16.93 on Quality Assurance Provisions for Fasteners.

Current edition approved April 10, 2002; Oct. 1, 2003. Published May 2002; October 2003. Originally published as F 812/F 812M – 83; approved in 1983. Last previous edition approved in 2002 as F 812/F 812M – 97a02.

F 606 Test Methods for Determining the Mechanical Properties of Externally and Internally Threaded Fasteners, Washers, and Rivets²

F 606M Test Methods for Determining the Mechanical Properties of Externally and Internally Threaded Fasteners, Washers, and Rivets [Metric]²

F 1470 Guide for Fastener Sampling for Specified Mechanical Properties and Performance Inspection²

F 1789 Terminology for F16 Mechanical Fasteners²

2.2 ISO Standard:

ISO/DIS 6157/II Fasteners, Surface Discontinuities on Nuts³

3. Ordering Information

3.1 Orders for nuts requiring surface discontinuity control shall include:

3.1.1 ASTM designation and date of issue of this specification.

3.1.2 Special requirements, for example, closer discontinuity limits (1.3.1) and inspection sampling plan (6.2).

4. Types of Surface Discontinuities (See Standard F 1789 for definitions not provided)

4.1 Crack:

4.1.1 *Quench Cracks*— Typical quench cracks are shown in Fig. 1; limits are specified in 5.2.

4.1.2 *Forging Cracks*— Typical forging cracks are shown in Fig. 2; limits are specified in 5.3.

4.1.3 *Inclusion Cracks*— Normally caused by nonmetallic inclusions or stringers inherent in the raw material. Typical inclusion cracks are shown in Fig. 2; limits are specified in 5.3.

4.1.4 *Locking-Element Cracks*—Occur due to application of pressure when forming the locking element of prevailing torque-type nuts. Such cracks are usually located in the vicinity of the locking element and may be either on the internal or external surface. Typical locking element cracks are shown in Fig. 3; limits are specified in 5.4.

4.1.5 *Washer-Retainer Cracks*—Openings in the lip or hub of metal used to retain a washer on a nut. Washer-retainer cracks may occur when pressure is applied to the lip or hub during assembly of the washer. Typical washer-retainer cracks are shown in Fig. 4; limits are specified in 5.5.

4.2 *Burst*—A typical burst is shown in Fig. 5; limits are specified in 5.6.

4.2.1 *Shear Burst*— A typical shear burst is shown in Fig. 5; limits are specified in 5.6.

4.3 *Seam*—Typical seams are shown in Fig. 6; limits are specified in 5.7.

4.4 *Fold*—Typical folds are shown in Fig. 7; limits are specified in 5.8.

4.5 *Void*—Voids are produced by marks or impressions of chips (shear burrs) or by rust formation on the raw material. They are not planished during forging. Typical voids are shown in Fig. 8; limits are specified in 5.9.

4.6 *Tool Marks*—Typical tool marks are shown in Fig. 9; limits are specified in 5.10.

4.7 *Nick (Gouge)*— Nicks or gouges are produced by the forceful abrasion or the impact of a product coming into contact with another product or manufacturing equipment during manufacture, handling, or transport. Limits are specified in 5.11.

5. Allowable Limits

5.1 *Letter Definitions*—Throughout the following requirements, *D* designates the nominal nut size (basic major diameter of thread); *D_c* designates flange diameter (specified maximum) on flanged nuts; *S* designates nominal (specified maximum) width across flats. For metric-series nuts, *D*, *D_c*, and *S* are in millimetres; for inch series nuts, *D*, *D_c*, and *S* are in inches.

5.2 *Quench Cracks*— Quench cracks of any depth, any length, or in any location are not permitted.

² Annual Book of ASTM Standards, Vol 01.08.

Annual Book of ASTM

³ Available from American National Standards, Vol 01.08, Institute (ANSI), 25 W. 43rd St., 4th Floor, New York, NY 10036.

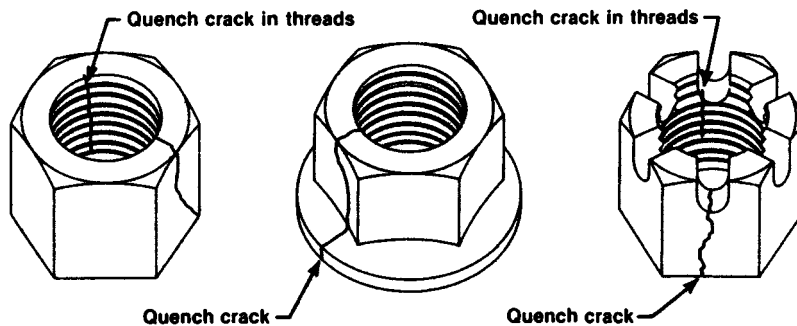

FIG. 1 Typical Quench Cracks in Nuts

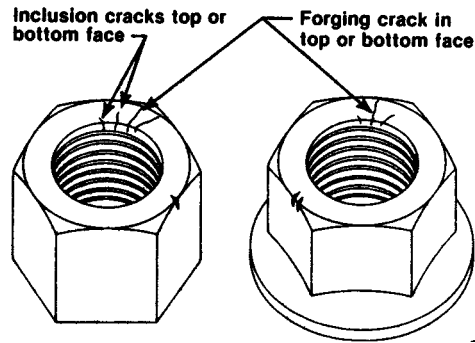

FIG. 2 Typical Forging and Inclusion Cracks in Nuts

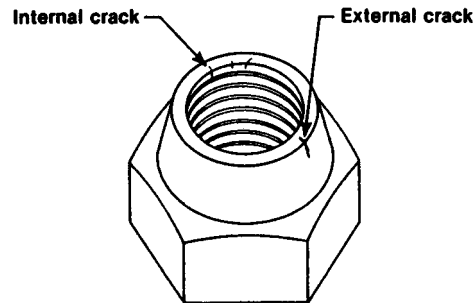

FIG. 3 Typical Locking Element Cracks in Prevailing-Torque Nuts

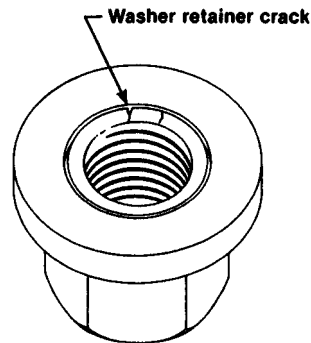

FIG. 4 Typical Washer Retainer Cracks in Nuts

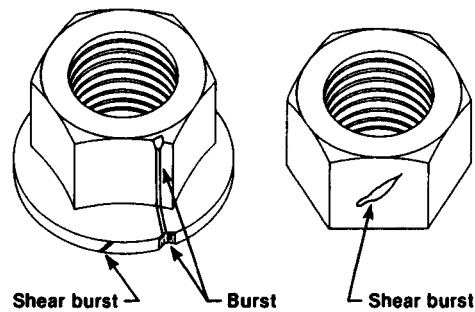

FIG. 5 Typical Bursts and Shear Bursts in Nuts

5.3 *Forging Cracks and Inclusion Cracks*—Forging and inclusion cracks located in the top and bottom faces of nuts of all sizes are permitted provided that (a) there are not more than two cracks that extend from the tapped hole across the full width of the face; (b) no crack extends into the tapped hole beyond the first full thread; (c) no crack in the threads exceeds a depth of 0.5 times the thread height; and (d) the width of any crack does not exceed 0.02 D or 0.30 mm or 0.012 in., whichever is greater.

5.3.1 Additionally, hex nuts with nominal diameters 5 to 36 mm inclusive and 1/4 to 1 1/2 in. inclusive, showing discontinuity indications, shall meet the requirements of the cone proof load test when sampled in accordance with 7.6.1, using samples selected in accordance with 7.6.5.2.

5.4 *Locking Element Cracks*:

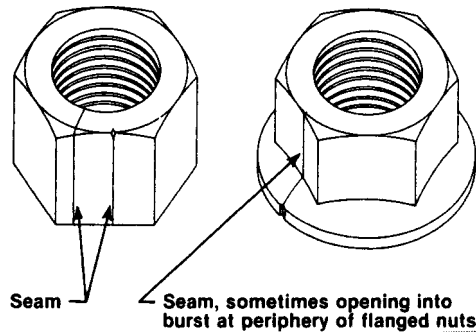

FIG. 6 Typical Seams in Nuts

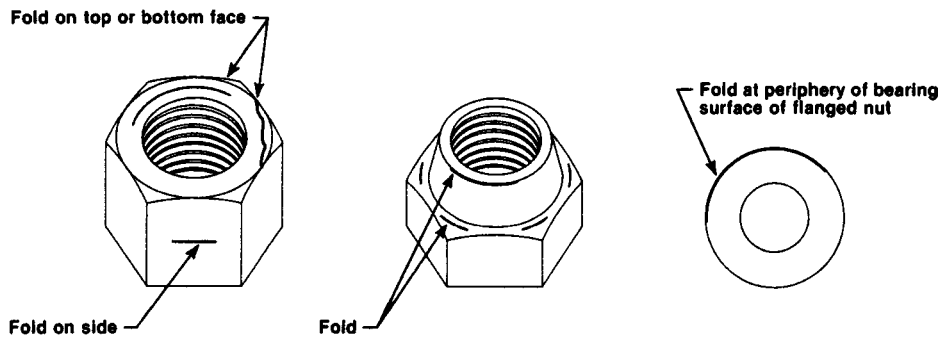

FIG. 7 Typical Folds on Surfaces of Nuts

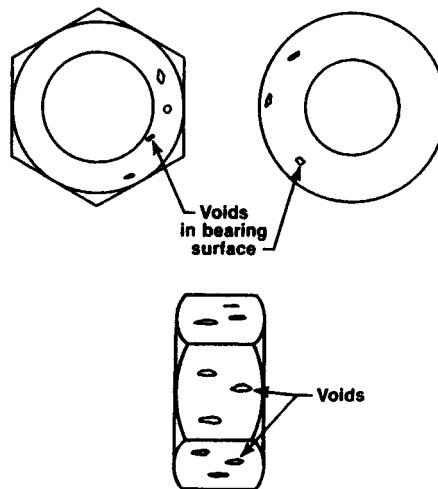

FIG. 8 Typical Voids in Nuts

5.4.1 Locking-element cracks (or seams) located on the external surface of the locking element of prevailing torque nuts are permitted provided that the net meets all applicable torque requirements.

5.4.1.1 Additionally, hex nuts with nominal diameters 5 to 36 mm inclusive and $\frac{1}{4}$ to $1\frac{1}{2}$ in. inclusive, showing discontinuity indications, shall meet the requirements of the cone proof load test when sampled in accordance with 7.6.1, using samples selected in accordance with 7.6.5.2.

5.4.2 Locking-element cracks located on the internal surface (threaded or unthreaded) of prevailing torque nuts are permitted provided that (a) no crack exceeds a length of two thread pitches; (b) no crack shall extend into the thread root; and (c) no crack shall have a width exceeding the following:

5.4.2.1 *Metric-Series Nuts*—0.18 mm for nuts with nominal diameters 5 to 10 mm inclusive, 0.25 mm for nuts with nominal diameters over 10 to 24 mm inclusive, and 0.40 mm for nuts with nominal diameters larger than 24 mm.

5.4.2.2 *Inch Series Nuts*—0.007 in. for nuts with nominal diameters $\frac{1}{4}$ to $\frac{7}{16}$ in. inclusive, 0.010 in. for nuts with nominal diameters over $\frac{7}{16}$ to 1 in. inclusive, and 0.016 in. for nuts with nominal diameters larger than 1 in.

5.5 *Washer-Retainer Cracks*—Washer-retainer cracks are permitted if their location is limited to the contour of the lip or hub used for retaining purposes.

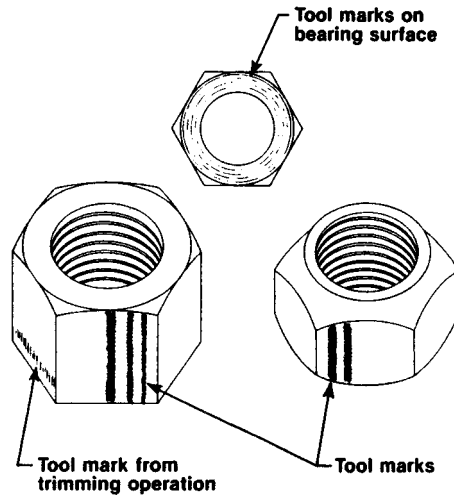

FIG. 9 Typical Tool Marks on Nut Surface

5.6 *Bursts and Shear Bursts:*

5.6.1 For hex nuts, bursts and shear bursts are permitted provided that (a) no burst or shear burst in the flats extends into the crown (chamfer) circle on the top of the nut or into the bearing circle on the bottom face; (b) no burst or shear burst located at the intersection of the top or bottom face with a wrenching flat has a width greater than 0.25 mm or 0.010 in. plus 0.02 S; and (c) no burst occurring at the intersection of two wrenching flats reduces the width across corners below its specified minimum.

5.6.2 For flanged nuts, bursts and shear bursts at the periphery of the flange are permitted provided that (a) not more than one of the bursts or shear bursts has a width greater than 0.04 Dc, and (b) the width of the one burst or shear burst that exceeds a width of 0.04 Dc does not have a width greater than 0.08 Dc.

5.7 *Seams*—Seams are permitted provided that no seam has an open width at the surface greater than 0.013 D for nuts with nominal diameters 5 to 6 mm inclusive; 0.02 D for metric nuts with nominal diameters larger than 6 mm; and 0.02 D for all sizes of inch-series nuts.

5.7.1 Additionally, hex nuts with nominal diameters 5 to 36 mm inclusive and ¼ to 1½ in. inclusive, showing discontinuity indications, shall meet the requirements of the cone proof load test when sampled in accordance with 7.1 6.1 using samples selected in accordance with 7.6.5.2.

5.8 *Folds*—Folds located at the intersection of the flange periphery and bearing surface of flanged nuts shall not project below the bearing surface. All other folds on nuts are permitted.

5.9 *Voids:*

5.9.1 Voids on the surfaces of nuts are permitted provided that (a) depth of voids does not exceed 0.25 mm or 0.010 in. or 0.02 D, whichever is greater, and (b) the combined area of all voids on the bearing surface does not exceed 10% of the specified minimum-bearing surface area.

5.9.2 The method for determining the area of voids on the bearing surface shall be as agreed upon by purchaser and producer.

5.10 *Tool Marks:*

5.10.1 Tool marks on the bearing surface are permitted provided the surface roughness measurement does not exceed 3.2 µm or 125 µin., determined as the arithmetic average deviation from the mean surface.

5.10.2 Tool marks on other surfaces of the nut are permitted.

5.11 *Nicks and Gouges*—Nicks, gouges, dents, and scrapes are permitted provided that the functionality of the nut is not impaired.

6. **Test Method**

6.1 *Cone Proof Load Test*—The cone proof load test shall be conducted in accordance with the Cone Proof Load Test Methods F-606 (Inch products), or F-606M (Metric products).

7. **Inspection and Evaluation**

7.1 Nuts shall be inspected for surface discontinuities in accordance with the procedures in 7.6.2, 7.6.3, and 7.6.4.

7.2 The purchaser shall specify in the original inquiry and purchase order the inspection sampling requirements which the producer must satisfy to demonstrate the acceptability of nuts with respect to surface discontinuities.

7.3 In the absence of purchaser instructions (7.2), inspection and evaluation shall be in accordance with 7.6.5.

7.4 For referee purposes, unless other procedures have been specified by the purchaser (7.2), inspection and evaluation shall be in accordance with 7.6.5.

7.5 *Inspection Procedure:*

76.5.1 Visual Inspection:

76.5.1.1 A random sample shall be taken from the lot in accordance with Guide F 1470, and examined visually for the presence of quench cracks, forging cracks, inclusion cracks, locking-element cracks, washer retainer cracks, bursts, shear bursts, seams, folds, voids, tool marks, and nicks and gouges.

76.5.1.2 If during this inspection any nuts with quench cracks are found, the lot may be rejected by the purchaser.

76.5.1.3 If during this inspection any nuts are found with any other surface discontinuity, each discontinuity shall be measured and if any is found that exceeds the allowable dimensional limits for that discontinuity as specified in Section 5, the lot may be rejected by the purchaser.

76.5.1.4 Measurement of Surface Discontinuities in Nuts:

(1) For discontinuities originating from a flat: at the extremity of the discontinuity measure distance *D* perpendicular to the flat where the discontinuity originated (see Fig. 10).

(2) For discontinuities originating from a corner: at the extremity of the discontinuity measure distance *D* in a straight line to the corner where the discontinuity originated (see Fig. 10).

76.5.2 Mechanical Testing—During the visual inspection, all hex nuts with nominal diameters 5 to 36 mm inclusive and ¼ to 1½ in. inclusive, that have indications of forging cracks, inclusion cracks, locking-element cracks on external surfaces, or seams, shall be set aside. From this lot, a sample of size in accordance with Guide F 1470, and consisting of those nuts indicating the most serious defects, shall be cone proof load tested as specified in 6.7.1. If any nut fails to meet the requirements of this test, the lot may be rejected by the purchaser.

7. Test Method

7.1 Cone Proof Load Test—If required in 6.5.2, the cone proof load test shall be conducted in accordance with the Cone Proof Load Test Methods F 606 (Inch products), or F 606M (Metric products).

8. Keywords

8.1 Crack; Discontinuities (Surface); Fold; Nut; Seam; Void.

ASTM International takes no position respecting the validity of any patent rights asserted in connection with any item mentioned in this standard. Users of this standard are expressly advised that determination of the validity of any such patent rights, and the risk of infringement of such rights, are entirely their own responsibility.

This standard is subject to revision at any time by the responsible technical committee and must be reviewed every five years and if not revised, either reapproved or withdrawn. Your comments are invited either for revision of this standard or for additional standards and should be addressed to ASTM International Headquarters. Your comments will receive careful consideration at a meeting of the responsible technical committee, which you may attend. If you feel that your comments have not received a fair hearing you should make your views known to the ASTM Committee on Standards, at the address shown below.

This standard is copyrighted by ASTM International, 100 Barr Harbor Drive, PO Box C700, West Conshohocken, PA 19428-2959, United States. Individual reprints (single or multiple copies) of this standard may be obtained by contacting ASTM at the above address or at 610-832-9585 (phone), 610-832-9555 (fax), or service@astm.org (e-mail); or through the ASTM website (www.astm.org).

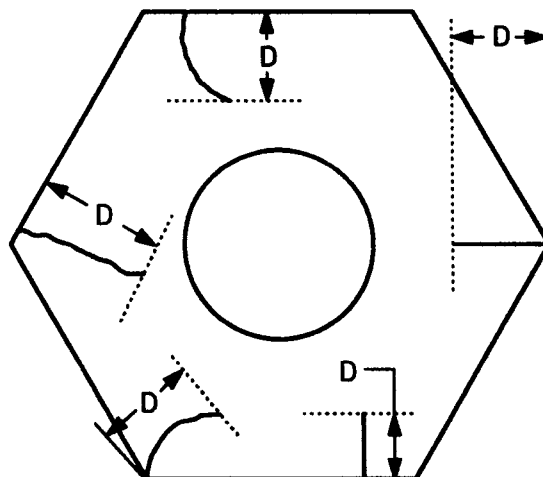

FIG. 10 Measurement of Surface Discontinuities