



Standard Specification for Bronze Trolley Wire¹

This standard is issued under the fixed designation B 9; the number immediately following the designation indicates the year of original adoption or, in the case of revision, the year of last revision. A number in parentheses indicates the year of last reapproval. A superscript epsilon (ϵ) indicates an editorial change since the last revision or reapproval.

1. Scope

1.1 This specification covers round, grooved, and figure-9 deep-section grooved bronze trolley wire.

1.2 The bronze trolley wire may be made in any of the three distinct alloys indicated in accordance with their increasing conductivities: Alloy 40, Alloy 55, Alloy 80.

1.3 The values stated in inch-pound units are to be regarded as the standard. The metric equivalents of inch-pound units given in this standard may be approximate.

2. Ordering Information

2.1 Orders for material under this specification shall include the following information:

- 2.1.1 Quantity of each size, section, and class,
- 2.1.2 Wire size: diameter in in. (see 5.1 and Table 1) or area in circular mils (see 8.1 and Fig. 1 and Fig. 2),
- 2.1.3 Shape of section (see 1.1),
- 2.1.4 Alloy (see 1.2),
- 2.1.5 Package size (see 17.3),
- 2.1.6 Lagging, if required (see 17.1),
- 2.1.7 Relation between vertical axis of grooved wire and axis of reel (see 17.1),
- 2.1.8 Size of arbor hole if other than 4-in. (102 mm) square (see 17.2),
- 2.1.9 Special package marking, if required (see 17.4), and
- 2.1.10 Place of inspection (Section 15).

3. Material

3.1 The material shall be bronze of such nature and composition (Explanatory Note 1) as to secure, by proper treatment, the qualities prescribed in this specification for the finished wire.

ROUND WIRE

4. Tensile Properties

4.1 Round wire shall conform to the requirements as to tensile properties prescribed in Table 1.

4.2 Tests on a specimen of round wire containing a joint shall show at least 95 % of the tensile strength specified in Table 1. Elongation tests shall not be made on specimens containing joints.

4.3 Tension tests shall be made on representative samples. The elongation shall be determined as the permanent increase in length, due to the breaking of the wire in tension, measured between gage marks placed originally 10 in. (254 mm) apart upon the test specimen (Explanatory Note 2). The fracture shall be between the gage marks and not closer than 1 in. (25.4 mm) to either gage mark.

5. Dimensions and Permissible Variations

5.1 The size of round trolley wire shall be expressed as the diameter of the wire in decimal fractions of an inch to the nearest 0.1 mil (0.0001 in.) (0.0025 mm).

5.2 Wire shall be truly cylindrical in form. The diameter shall not vary more than ± 1 % from that specified.

6. Twist Test

6.1 For the purpose of determining and developing defects which may be prejudicial to the life of trolley wire, owing to its peculiar service as compared to that of wire for other purposes, round wire shall be subjected to the twist test described in 6.2. Round wire shall not be considered satisfactory if it does not withstand, without breaking, at least the number of twists prescribed in Table 2.

6.2 Three twist tests shall be made on specimens 10 in. (254 mm) in length between the holders of the testing machine. The twisting machine shall be so constructed that there is a linear motion of the tail stock with respect to the head. The twist shall be applied not faster than 10 turns/min. All three specimens shall be twisted to destruction and shall not reveal under test any seams, pits, slivers, or surface imperfections of sufficient magnitude to indicate inherent defects or imperfections in the wire. At the time of fracture the wire shall twist with reasonable uniformity.

GROOVED AND FIGURE-9 WIRE

7. Tensile Properties

7.1 Grooved and figure-9 wire shall conform to the applicable requirements as to tensile properties prescribed in Table 3.

¹ This specification is under the jurisdiction of ASTM Committee B01 on Electrical Conductors and is the direct responsibility of Subcommittee B01.04 on Conductors of Copper and Copper Alloys.

Current edition approved October 1, 2003. Published October 2003. Originally approved in 1915. Last previous edition approved in 1998 as B 9 – 90 (1998)^{\epsilon}2.

TABLE 1 Tensile Requirements for Round Trolley Wire

Diameter		Area		Tensile Strength, min				Elongation in 10 in. (254 mm), min, %
in.	mm	cmil	mm ²	Alloys 40 and 55		Alloy 80		
				psi	MPa	psi	MPa	
0.5477	13.911	300 000	152.0	64 800	447	61 500	424	4.50
0.4600	11.648	211 600	107.0	69 000	476	65 000	448	3.75
0.4096	10.404	167 800	85.0	71 000	490	67 000	462	3.25
0.3648	9.266	133 100	67.4	73 000	503	69 000	476	2.75
0.3249	8.252	105 600	53.5	76 000	524	72 000	496	2.40

7.2 Tests on a specimen of grooved or figure-9 wire containing a joint shall show at least 95 % of the tensile strength specified in Table 3. Elongation tests shall not be made on specimens containing joints.

7.3 The tension and elongation tests for grooved or figure-9 wire shall be made in the same manner as those on round wire as described in 4.3.

8. Dimensions and Permissible Variations

8.1 The size of the trolley wire shall be expressed as the nominal area of cross section in circular mils.

8.2 The standard sizes of grooved trolley wire shall be as specified in Fig. 1.

8.3 The standard size of figure-9 wire shall be as specified in Fig. 2.

8.4 The weight in pounds per mile of grooved and figure-9 trolley wire calculated from the weight of a specimen not less than 18 in. (460 mm) in length shall not vary more than ± 4 % from that specified in Fig. 1 for grooved wire, and Fig. 2 for figure-9 wire.

8.5 Conformance of the trolley wire to the specified dimensions shall be determined by taking the measurements shown in Fig. 1 and Fig. 2 under the heading, "Dimensions for Inspection, in." The shape of the groove shall be checked with the appropriate "go" and "no-go" slip gages described in Fig. 3. The gages shall be applied to the ends of the samples taken from each reel. Samples shall be clean and the ends free from burrs. The groove shall be considered as conforming to this specification if the "go" gage can be pushed on the straightened wire by hand and the "no-go" gage cannot be pushed on the wire.

9. Sections

9.1 Standard sections of grooved trolley wire shall be known as the "American Standard Grooved Trolley Wire Sections" (the Standard Design of the American Transit Engineering Association) shown in Fig. 1.

9.2 The standard section of figure-9 wire shall be as shown in Fig. 2.

10. Twist Test

10.1 For the purpose of determining and developing defects that may be prejudicial to the life of trolley wire, owing to its peculiar service as compared to that of wire for other purposes, grooved wire shall be subjected to the twist test described in 6.2. Grooved wire that does not withstand at least three twists without breaking shall not be considered satisfactory. The twist test shall be omitted for figure-9 wire.

ROUND, GROOVED, AND FIGURE-9 WIRE

11. Resistivity

11.1 Electrical resistivity shall be determined on representative samples by resistance measurements (Explanatory Note 3). At a temperature of 20°C the resistivity shall not exceed the values prescribed in Table 4.

11.2 Lower resistivities in wires conforming to the physical qualifications may be obtained by the use of special alloys.

12. Density

12.1 For the purpose of calculating mass, cross-sections, and so forth, the density of the bronze (Explanatory Note 4) shall be taken as 8.89 g/cm³ (0.32117 lb/in.³) at 20°C (Explanatory Note 5).

13. Joints

13.1 No joints shall be made in the completed wire. Joints in the wire and rods made prior to final drawings shall be in accordance with the best commercial practice, and shall be capable of meeting the tensile strength requirements in 4.2 or 7.2.

14. Workmanship, Finish, and Appearance

14.1 The wire shall be of uniform size, shape, and quality throughout, and shall be free from all scale, flaws, splits, and scratches not consistent with the best commercial practice.

15. Inspection

15.1 All tests governing the acceptance or rejection of the wire, unless otherwise specified, shall be made at the place of manufacture with apparatus furnished by the manufacturer and in the presence of the purchaser or his representative, who shall be furnished a copy of the tests. The manufacturer shall afford the inspector representing the purchaser all reasonable facilities to satisfy him as to the reliability of the results before the wire is delivered. If the purchaser waives inspection, and if he so elects at that time, he shall be furnished with a certified copy of tests made by the manufacturer.

16. Rejection

16.1 Any reel of wire that fails to conform to the requirements prescribed in this specification may be rejected. Failure of 30 % of the number of reels ready for inspection at one time shall be deemed sufficient cause for the rejection of the whole lot.

 B 9 – 90 (2003)

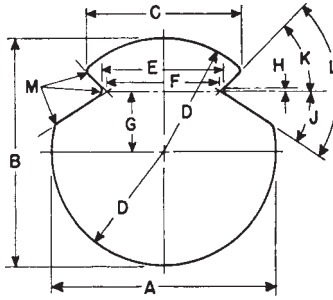

Nominal Size:					
cmil	133 100	167 800	211 600	300 000	350 000
(mm ²)	(67.4)	(85.0)	(107.00)	(152.0)	(177.3)
Area (Explanatory Note 6):					
cmil	137 900	167 300	212 000	299 800	351 200
in ²	0.1083	0.1314	0.1665	0.2355	0.2258
(mm ²)	(69.9)	(84.7)	(107.4)	(151.9)	(177.9)
Weight (Explanatory Note 6):					
lb/mile	2205	2674	3389	4792	5612
(kg/km)	(621)	(756)	(955)	(1350)	(1581)
Dimensions for Inspection, in.					
A	0.388 ^{+0.006} _{-0.012}	0.429 ^{+0.006} _{-0.012}	0.482 ^{+0.006} _{-0.012}	0.574 ^{+0.010} _{-0.020}	0.620 ^{+0.010} _{-0.020}
B	0.392 ± 0.007	0.430 ± 0.008	0.482 ± 0.009	0.574 ± 0.011	0.620 ± 0.012
C	0.318 ± 0.007 ^{A +}	0.340 ± 0.007	0.376 ± 0.007	0.376 ± 0.007	0.376 ± 0.007
Dimensions for Inspection, mm					
A	9.86 ^{+0.1524} _{-0.3048}	10.6 ^{+0.1524} _{-0.3048}	12.2 ^{+0.1524} _{-0.3048}	14.6 ^{+0.254} _{-0.508}	15.7 ^{+0.254} _{-0.508}
B	9.96 ± 0.1778	10.9 ± 0.2032	12.2 ± 0.2286	14.6 ± 0.2794	15.7 ± 0.3048
C	8.08 ± 0.1778	8.64 ± 0.1778	9.55 ± 0.1778	9.55 ± 0.1778	9.55 ± 0.1778
Dimensions for Reference, in.					
D—radius	0.196	0.215	0.241	0.287	0.310
E	0.217 ^{+0.005} _{-0.010}	0.237 ^{+0.005} _{-0.010}	0.267 ± 0.010	0.267 ± 0.010	0.267 ± 0.010
F	0.200	0.220	0.250	0.250	0.250
G	0.031	0.047	0.063	0.127	0.156
H	0.005	0.005	0.005	0.005	0.005
J	27 ± 2°	27 ± 2°	27 ± 2°	27 ± 2°	27 ± 2°
K	51 ± 2°	51 ± 2°	51 ± 2°	51 ± 2°	51 ± 2°
L	78°	78°	78°	78°	78°
M—radius	0.015 ^{+0.010} _{-0.005}	0.015 ^{+0.010} _{-0.005}	0.015 ^{+0.010} _{-0.005}	0.015 ^{+0.010} _{-0.005}	0.015 ^{+0.010} _{-0.005}
Dimensions for Reference, mm					
D—radius	4.98	5.46	6.12	7.29	7.84
E	5.51 ^{+0.127} _{-0.234}	6.02 ^{+0.127} _{-0.254}	6.78 ± 0.254	6.78 ± 0.254	6.78 ± 0.254
F	5.08	5.59	6.35	6.35	6.35
G	0.7874	1.194	1.60	3.23	3.96
H	0.127	0.127	0.127	0.127	0.127
M—radius	0.381 ^{+0.254} _{-0.127}	0.381 ^{+0.254} _{-0.127}	0.381 ^{+0.254} _{-0.127}	0.381 ^{+0.254} _{-0.127}	0.381 ^{+0.254} _{-0.127}

^{A +}Editorially corrected.

NOTE 1—Dimensions H is defined by two center lines of which the upper is the center line of the radius of the groove and the lower is the center line of the groove.

FIG. 1 Standard Sections Grooved Trolley Wire

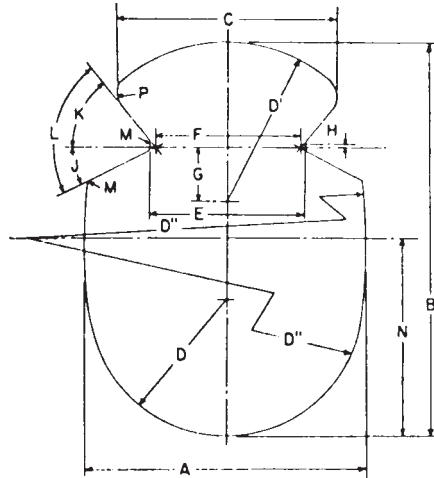

Nominal Size, cmil		335 000
Area:		0.2642
in. ² (Explanatory Note 6)		(170.5)
(mm ²)		336 400
cmil		5386
Weight:		(1517)
lb/mile (Explanatory Note 6)		
(kg/km)		
Dimensions for Inspection		
	in.	(mm)
A (at dimension N)	0.482 ^{+0.006} _{-0.012}	12.2 ^{+0.0015} _{-0.3048}
B	0.680 ± 0.012	(17.3 ± 0.3048)
C	0.376 ± 0.007	(9.55 ± 0.1778)
Dimensions for Reference		
	in.	(mm)
D	0.235	(5.97)
D'—radius	0.275	(6.98)
D''—radius	0.960	(24.4)
E	0.267 ± 0.010	(6.78 ± 0.25)
F	0.250	(6.35)
G	0.093	(2.36)
H	0.005	(1.27)
J	27 ± 2°	(27 ± 2°)
K	51 ± 2°	(51 ± 2°)
L	78°	(78°)
M—radius	0.015 ^{+0.010} _{-0.005}	(3.81) ^{+0.254} _{-0.127}
N	0.342	(8.69)
P—radius	0.037 ± 0.007	(0.940 ± 0.1778)

NOTE—Dimension H is defined by two center lines of which the upper is the center line of the radius of the groove and the lower is the center line of the groove.

FIG. 2 Standard Section Figure-9 Deep-Section Grooved Trolley Wire

TABLE 2 Twist Test Requirements for Round Wire

Diameter		Number of Twists
in.	mm	
0.5477	13.911	20
0.4600	11.684	23
0.4096	10.404	25
0.3648	9.266	27
0.3249	8.252	30

TABLE 3 Tensile Requirements for Grooved and Figure-9 Trolley Wire

Nominal Area, cmil	Tensile Strength, Minimum				Elongation in 10 in. (254 mm), min, %
	Alloys 40 and 55		Alloy 80		
	psi	MPa	psi	MPa	
Grooved:					
350 000	62 500	431	59 500	410	4.00
300 000	64 800	447	61 500	424	4.00
211 600	69 000	476	65 000	448	3.25
167 800	71 000	490	67 000	462	2.75
133 100	73 000	503	69 000	476	2.25
Figure-9:					
335 000	61 500	424	56 800	392	4.00

17. Packaging and Package Marking

17.1 All wire shall be shipped on substantial reels, suitable for the weight of the wire handled, and shall be well protected

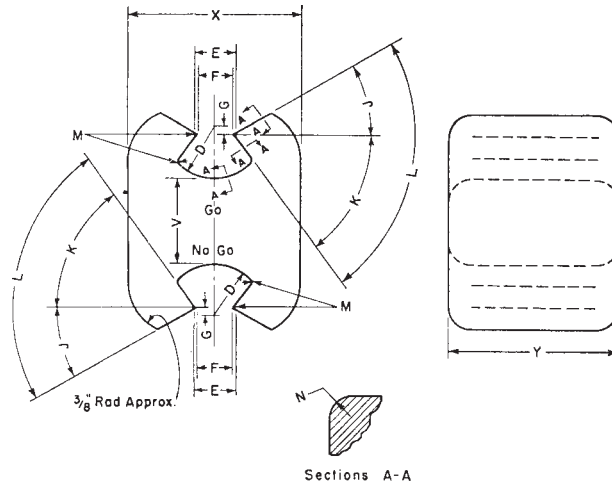

Dimension	Dimensions of Gage, in. (Except as Indicated)					
	For Trolley Wire of Nominal Size 133 100 cmil		For Trolley Wire of Nominal Size 167 800 cmil		For Trolley Wire of Nominal Sizes 211 600, 300 000, 335 000 and 350 000 cmil	
	Go	No-Go	Go	No-Go	Go	No-Go
D	5/16	5/16	5/16	5/16	5/16	5/16
E	0.223 ± 0.0005	0.207 ^{+0.000} _{-0.001}	0.243 ± 0.0005	0.227 ^{+0.000} _{-0.001}	0.278 ± 0.0005	0.257 ^{+0.000} _{-0.001}
F	0.212	0.200	0.235	0.220	0.268	0.248
G	0.031	0.031	0.047	0.047	0.063	0.063
J	25°	29°	25°	29°	25°	29°
K	53°	53°	53°	53°	53°	53°
L	78°	82°	78°	82°	78°	82°
M—radius	0.010 ± 0.002	0.010 ± 0.002	0.010 ± 0.002	0.010 ± 0.002	0.010 ± 0.002	0.010 ± 0.002
N—radius	5/16	5/16	5/16	5/16	5/16	5/16
V	1/2	1/2	1/2	1/2	1/2	1/2
X	1	1	1	1	1	1
Y	1	1	1	1	1	1

Dimensions of Gage, mm						
D	7.94	7.94	7.94	7.94	7.94	7.94
E	5.66 ± 0.0127	5.26 ^{+0.000} _{-0.0254}	6.17 ± 0.0127	5.77 ^{+0.000} _{-0.0254}	7.06 ± 0.0127	6.53 ^{+0.000} _{-0.0254}
F	5.38	5.08	5.97	5.59	6.81	6.30
G	0.7874	0.7874	1.19	1.19	1.60	1.60
M—radius	2.54 ± 0.0508	2.54 ± 0.0508	2.54 ± 0.0508	2.54 ± 0.0508	2.54 ± 0.0508	2.54 ± 0.0508
N—radius	1.587	1.587	1.587	1.587	1.587	1.587
V	12.7	12.7	12.7	12.7	12.7	12.7
X	25.4	25.4	25.4	25.4	25.4	25.4
Y	25.4	25.4	25.4	25.4	25.4	25.4

FIG. 3 Slip Gage for Testing Groove of Trolley Wire

TABLE 4 Requirements for Electrical Resistivity

Wire	Resistivity at 20°C (68°F), Ω·lb/mile ²	Ω · g/m ²
Alloy 40	2188	0.3832
Alloy 55	1591	0.2786
Alloy 80	1094	0.1916

from injury. The diameter of the reel drums shall be sufficiently large, not less than 30 in. (760 mm), to eliminate difficulty with waves or kinks when the wire is strung. If reels are to be lagged, it shall be so specified by the purchaser. The wire shall be reeled with turns tightly together, in uniform layers, free from kinks and crosses. The relation between the vertical axis of grooved wire as finally strung and the axis of the reel shall be as specified by the purchaser and shall be approximately constant.

17.2 The ends of the wire shall be securely fastened to the sides of the reel with no less than six staples. The staples shall be at least 2 in. (50 mm) in length and made from wire not less than 0.145 in. (3.68 mm) in diameter. Care shall be exercised in stapling not to damage the surface of the exposed layer of wire. All reels shall have the arbor holes reinforced with steel plate at least 1/2 in. (12.5 mm) in thickness, and unless otherwise specified, the arbor hole shall be a 4-in. (102 mm) square hole.

17.3 The length or weight of the wire to be wound upon each reel shall be agreed upon between the manufacturer and the purchaser in placing individual orders.

17.4 Reels shall be marked legibly and indelibly with a serial number, size, kind, length, weight of wire, and such other information as is specified by the purchaser.

18. Keywords

18.1 bronze trolley wire; figure 9 grooved trolley wire; grooved trolley wire; round bronze trolley wire; trolley wire

TABLE 5 Resistivity Values

Conductivity at 20°C (68°F), %	100.00	80.00	65.00	55.00	40.00
Ω-lb/mile ²	875.20	1094.00	1346.46 ^A	1591.27 ^A	2188.00
Ω-g/m ²	0.15328	0.19160	0.23582	0.27868	0.38320
Ω-cmil/ft	10.371	12.964	15.956	18.857	25.928
Ω-mm ² /m	0.017241	0.021551	0.026525	0.031348	0.043103
μΩ-in.	0.67879	0.84849	1.0443	1.2342	1.6970
μΩ-cm	1.7241	2.1551	2.6525	3.1348	4.3103

^A These values are carried out to two decimal places to indicate somewhat more precisely than in 11.1 the resistivity equivalent to 55 and 65 % conductivity.

EXPLANATORY NOTES

NOTE 1—Where wire is to be used for steam-railway electrification, the corrosive action of locomotive gases should be given consideration.

NOTE 2—It is known that the rapidity with which load is applied to a sample during tension testing affects the performance of the sample to a greater or lesser extent depending upon many factors. In general, tested values of tensile strength are increased and elongation values are reduced with increase of speed of the moving head of the testing machine. However, there are speeds below where no practical change is observable. It is suggested that tests be made at speeds of moving head which, under no-load conditions, are not greater than 3 in. (75 mm)/min, but in no case at a speed greater than that at which correct readings can be made. No minimum restriction on speed of testing seems necessary.

NOTE 3—“Resistivity” is used in place of “conductivity.” The value of 0.15328 Ω-g/m² at 20°C is the international standard for the resistivity of annealed copper equal to 100 % conductivity. This term means that a wire 1 m in length and weighing 1 g would have a resistance of 0.15328 Ω. This is equivalent to a resistivity value of 875.20Ω-lb/mile² which signifies the resistance of a wire 1 mile in length weighing 1 lb. It is also equivalent, for example, to 1.7241 μΩ/cm of length of a bar 1 cm² in cross section. A complete discussion of this subject is contained in *NBS*

Handbook 100 of the National Bureau of Standards.² Relationships which may be useful in connection with the values of resistivity prescribed in this specification are as shown in Table 5, each column containing equivalent expressions, at 20°C.

NOTE 4—Bronze trolley wire as commonly produced is made from an alloy of not less than 98 % copper with other metals. Determinations of the density of these alloys indicate, as might be expected, an average density practically the same as that found for copper.

NOTE 5—The value of the density of copper is in accordance with the International Annealed Copper Standard. The corresponding value at 0°C is 8.90 g/cm³ (0.32150 lb/in.³). As pointed out in the discussion of this subject in *NBS Handbook 100* there is no appreciable difference in values of density of hard-drawn and annealed copper wire.

NOTE 6—The values for area in square inches and circular mils as well as the weight in pounds per mile are calculated from the dimensions given in Fig. 1 for grooved wire and Fig. 2 for figure-9 wire.

² *NBS Handbook 100*, available from National Technical Information Service (NTIS), U.S. Department of Commerce, 5285 Port Royal Rd., Springfield, VA 22161.

ASTM International takes no position respecting the validity of any patent rights asserted in connection with any item mentioned in this standard. Users of this standard are expressly advised that determination of the validity of any such patent rights, and the risk of infringement of such rights, are entirely their own responsibility.

This standard is subject to revision at any time by the responsible technical committee and must be reviewed every five years and if not revised, either reapproved or withdrawn. Your comments are invited either for revision of this standard or for additional standards and should be addressed to ASTM International Headquarters. Your comments will receive careful consideration at a meeting of the responsible technical committee, which you may attend. If you feel that your comments have not received a fair hearing you should make your views known to the ASTM Committee on Standards, at the address shown below.

This standard is copyrighted by ASTM International, 100 Barr Harbor Drive, PO Box C700, West Conshohocken, PA 19428-2959, United States. Individual reprints (single or multiple copies) of this standard may be obtained by contacting ASTM at the above address or at 610-832-9585 (phone), 610-832-9555 (fax), or service@astm.org (e-mail); or through the ASTM website (www.astm.org).