



Designation: E 448 – 82 (Reapproved 1997)<sup>ε2</sup>

## Standard Practice for Scleroscope Hardness Testing of Metallic Materials<sup>1</sup>

This standard is issued under the fixed designation E 448; the number immediately following the designation indicates the year of original adoption or, in the case of revision, the year of last revision. A number in parentheses indicates the year of last reapproval. A superscript epsilon ( $\epsilon$ ) indicates an editorial change since the last revision or reapproval.

<sup>ε1</sup> NOTE—Section 20 was added editorially in October 1997.

<sup>ε2</sup> NOTE—Note 1 was editorially revised in December 2001.

### 1. Scope

1.1 This practice covers the determination of the Scleroscope<sup>2</sup> hardness of metallic materials (Part A), the verification of Scleroscope hardness instruments (Part B), and the calibration of standardized hardness test blocks (Part C).

1.2 The values stated in SI units are to be regarded as the standard. The values given in parentheses are for information only.

1.3 *This standard does not purport to address all of the safety problems, if any, associated with its use. It is the responsibility of the user of this standard to establish appropriate safety and health practices and determine the applicability of regulatory limitations prior to use.*

### 2. Referenced Documents

#### 2.1 ASTM Standards:

A 427 Specification for Wrought Alloy Steel Rolls for Cold and Hot Reduction<sup>3</sup>

E 140 Hardness Conversion Tables for Metals (Relationship Among Brinell Hardness, Vickers Hardness, Rockwell Hardness, Rockwell Superficial Hardness, and Knoop Hardness, and Scleroscope Hardness)<sup>4</sup>

### 3. Terminology

#### 3.1 Definitions:

3.1.1 *calibration*—determination of the values of the significant parameters by comparison with values indicated by a reference instrument or by a set of reference standards.

3.1.2 *forged roll Scleroscope hardness number (HFRSc or HFRSd)*<sup>5</sup>—a number related to the height of rebound of a diamond-tipped hammer dropped on a forged steel roll. It is measured on a scale determined by dividing into 100 units the

average rebound of a hammer from a forged steel roll of accepted maximum hardness.

NOTE 1—The flat striking surface of the hammer in the forged roll Scleroscope is slightly larger than the corresponding surface in the Scleroscope described in 3.1.3 (see Fig. 1). Hence the forged roll

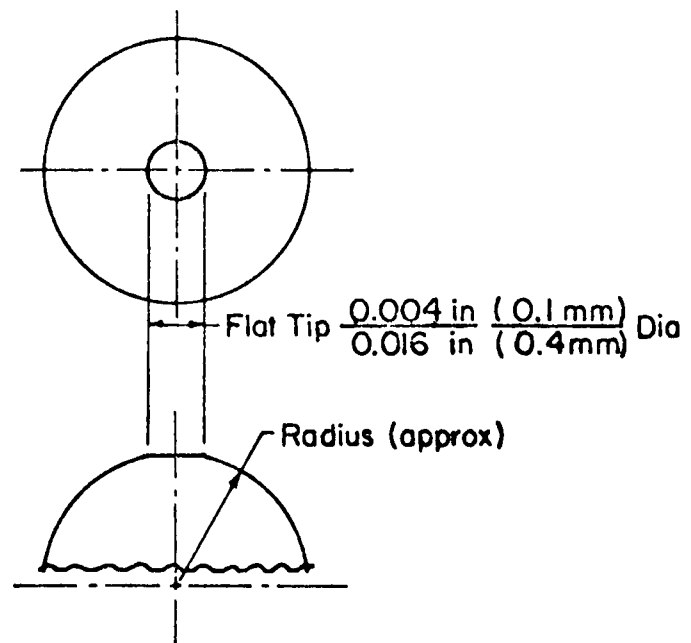

FIG. 1 Profile of Scleroscope Diamond Showing Range of Diameters of Flat Tip

Scleroscope yields correspondingly higher hardness numbers.

3.1.3 *Scleroscope hardness number (HSc or HSd)*—a number related to the height of rebound of a diamond-tipped hammer dropped on the material being tested. It is measured on a scale determined by dividing into 100 units the average rebound of the hammer from a quenched (to maximum hardness) and untempered high carbon water-hardening tool steel test block of AISI W-5.

3.1.4 *Scleroscope hardness test*—a dynamic indentation hardness test using a calibrated instrument that drops a diamond-tipped hammer (Note 2) from a fixed height onto the

<sup>1</sup> This practice is under the jurisdiction of ASTM Committee E-28 on Mechanical Testing and is the direct responsibility of E28.06 on Indentation Hardness Testing. Current edition approved July 30, 1982. Published December 1982. Originally published as E 448– 72. Last previous edition E 448 – 72 (1977).

<sup>2</sup> Registered trademark of the Shore Instrument & Mfg. Co., Inc.

<sup>3</sup> *Annual Book of ASTM Standards*, Vol 01.05.

<sup>4</sup> *Annual Book of ASTM Standards*, Vol 03.01.

<sup>5</sup> The conversion from Forged Roll “C” Scleroscope hardness to Vickers hardness contained in Specification A 427 and to Rockwell C hardness contained in Standard E 140 are presently the only Scleroscope hardness conversions in ASTM standards.



surface of the material under test. The height of rebound of the hammer is a measure of the hardness of the material.

NOTE 2—An all-steel “Magnifier Hammer” that yielded a greater spread in hardness readings on soft nonferrous metals has been available. This hammer has become obsolete and, hence, is not considered in this practice.

3.1.5 *verification*—checking or testing the instrument to assure conformance with the specification.

## GENERAL DESCRIPTION OF INSTRUMENTS AND TEST PROCEDURE FOR SCLEROSCOPE HARDNESS TEST

### 4. Apparatus

4.1 The instrument used for determining Scleroscope hardness numbers is supplied in two models designated Model C and Model D.<sup>6</sup>

4.2 *Scleroscope Model C*—This model consists of a vertically disposed barrel containing a precision bore glass tube. A scale, graduated from 0 to 140, is set behind and is visible through the glass tube. A pneumatic actuating head, affixed to the top of the barrel, is manually operated by a rubber bulb and tube. A hammer drops from a specified height and rebounds within the glass tube.

4.3 *Scleroscope Model D*—This model is known as the Dial Recording Scleroscope. It consists of a vertically disposed barrel containing a clutch to arrest the hammer at maximum height of rebound. This is made possible by using a hammer which is longer and heavier than the hammer in the Model C Scleroscope, and which develops the same striking energy in dropping through a shorter distance. A number of supporting devices are available with this instrument and it is recommended that one of these be used (see section 4.5).

#### 4.4 *Diamond-Tipped Hammers:*

4.4.1 There are two sizes of diamond-tipped hammers commonly used in the Scleroscope hardness instruments. These are the small hammer used in the Model C instrument and the larger hammer used in the Model D instrument.

4.4.2 The following dimensions are applicable to the diamond-tipped hammers:

	Model C
Diameter	0.234 in. (5.94 mm)
Mass	2.300 ± 0.500 g
Over-all length	0.815 to 0.840 in. (20.7 to 21.3 mm)
Distance hammer falls	9.890 + 0.005, -0.015 in. (251.2 + 0.1, -0.4 mm)
	Model D
Diameter	0.3125 in. (7.94 mm)
Mass	36.0 ± 2.0 g
Over-all length	3.990 to 4.010 in. (101.33 to 104.10 mm)
Distance hammer falls	0.704 + 0.017, -0.021 in. (17.9 + 0.4, -0.5 mm)

4.4.3 The geometry of the diamond tip is of significance only at its ultimate extremity because of the limited penetration of the diamond into the material being tested. Such penetration is about 0.001 in. (0.025 mm) on mild steel and about 0.0005 in. (0.013 mm) on hardened tool steel. Further, the variation in hardness of commercially available industrial diamonds has a

significant effect on the readings of a rebound-type hardness instrument. Consequently, the geometry of the diamond must be shaped to produce a correct reading on reference bars of known hardness. In the forged roll Scleroscope the diamond tip is specifically dimensioned to produce a correct reading on a forged-steel roll of known hardness. In profile, the diamond is convex, having an approximate radius terminated by a flat striking surface, as shown in Fig. 1. The flat striking surface is approximately circular and from 0.004 to 0.016 in. (0.1 to 0.4 mm) in diameter, depending on the type of instrument and the hardness and other physical characteristics of the diamond.

4.5 *Supporting Devices*—The three supporting devices used most frequently with the Scleroscope are (a) the clamping stand, (b) the swing arm and post, and (c) the roll-testing stand.

### 5. Test Specimens

5.1 *Form*—Specimens used in Scleroscope testing vary greatly with respect to size and shape. Smaller specimens may be tested in the clamping stand which has a jaw capacity of 3 in. (76 mm) high by 2½ in. (64 mm) deep. Large specimens, beyond the jaw capacity of the clamping stand, may be tested with the instrument mounted on the swing arm and post or the roll-testing stand. The swing arm and post has a height and reach capacity of 9 in. (230 mm) and 14 in. (360 mm), respectively. The roll-testing stand may be used for mounting the instrument on cylindrical specimens with a diameter of 2½ in. (64 mm) and upward without limit. The roll-testing stand may also be used for mounting the instrument on flat, horizontal surfaces with a minimum perimetric dimension of 3 by 5 in. (76 by 130 mm). The Model C Scleroscope may be used free hand for testing specimens with a minimum mass of 5 lb (2.3 kg). It is not recommended that the Model D Scleroscope be used free hand.

5.2 *Thickness*—Thin strips or sheets may be tested, with some limitations, but only when the Scleroscope is mounted in the clamping stand. Ideally, the sheet should be flat and without undulation. If the sheet material is bowed, the concave side should be up to preclude any possibility of erroneous readings due to spring effect. The minimum thicknesses of sheet in various categories that may be tested are as follows:

Material	Thickness	
	in.	mm
Hard steel	0.005 to 0.006	0.13 to 0.15
Half-hard brass strip	0.010	0.25
Cold-rolled steel	0.010	0.25
Annealed-brass sheet	0.015	0.38

5.3 *Finish*—The degree of test-surface finish is important.

<sup>6</sup> Model C and D Scleroscopes are manufactured by the Shore Instrument and Manufacturing Co., Inc., Jamaica, NY.

An excessively coarse finish will yield low and erratic readings. Hence, when necessary, the surface shall be filed, machined, ground, or polished to permit accurate, consistent readings to be obtained. Care should be taken to avoid overheating or excessively cold working the surface. The surface finish required to obtain reproducible results varies with the hardness of the test specimen. In proceeding from soft metals to hardened steel the required surface finish ranged from a minimum finish as produced by a No. 2 file to a finely ground or polished finish. For intermediate hardness metals a No. 125 machined surface, minimum, finish is required.

## 6. Verification of Apparatus

6.1 *Verification Method*—The instrument shall be verified as specified in Part B.

## 7. Procedure

7.1 *Test Method*—To perform a test with either the Model C or Model D Scleroscope, hold or set the instrument in a vertical position with the bottom of the barrel in firm contact with the test specimen. Bring the hammer to the elevated position and then allow it to fall and strike the test surface and measure the height of rebound. When using the Model C Scleroscope bring the hammer to the elevated position by squeezing and releasing the rubber bulb. Release the hammer by again squeezing the rubber bulb. The height to which the hammer rebounds on the first bounce indicates the hardness of the material. When using the Model D Scleroscope bring the hammer to the elevated position by turning the knurled control knob clockwise until a definite stop is reached. Release this control knob to allow the hammer to strike the specimen and observe the reading recorded on the dial. The dial hand comes to rest at a value that indicates the hardness of the material. Although the dial hand returns momentarily to zero in the course of each test cycle, it does not normally remain at zero.

7.2 *Alignment*—To prevent errors resulting from misalignment the instrument must be set or held in a vertical position, using the plumb bob or spirit level on the instrument to determine verticality. The most accurate readings of the Scleroscope are obtained with the instrument mounted in the clamping stand, which is essentially a C clamp with a tripod mounting to facilitate levelling of the anvil and to ensure verticality of the barrel. The opposite sides of the specimens tested in the clamping stand must be parallel. Lateral vibrations must be avoided since they tend to cause the free fall of the hammer to be impeded and, hence, cause the instrument to read low.

7.3 *Spacing of Indentations*—An error may result if the indentations are spaced too closely together. Space indentations at least 0.020 in. (0.51 mm) apart and make only once at the same spot. Flat specimens with parallel surfaces may be tested within ¼ in. (6 mm) of the edge when properly clamped.

7.4 *Magnetization*—Do not make tests on magnetized materials. Any magnetization of specimen or hammer will result in low readings.

7.5 *Reading the Scleroscope*—Experience is necessary to read the Model C Scleroscope accurately. Thin materials or those weighing less than 5 lb (2.3 kg) must be clamped to acquire the inertia of the support. The sound of the impact is an indication of the effectiveness of the clamp: a dull thud indicates that the sample has been clamped solid, whereas a hollow ringing sound indicates that the sample is not tightly clamped or is warped and not properly supported. Five hardness determinations should be made and their average taken as representative of the hardness of a particular sample.

## 8. Accuracy

8.1 The accuracy of the Scleroscope Hardness Method is related to (1) the accuracy of the mass and geometry of the hammer, (2) the distance the hammer falls during a test, (3) the condition of the test and support surfaces, and (4) the support of the test piece during the test. Under optimum conditions, the accuracy that can be expected is  $\pm 3$  Scleroscope points from the mean of the spread in Scleroscope hardness numbers marked on the standardized reference hardness test blocks (see Section 13). Under less than ideal conditions, any reduction in accuracy can be established empirically by employing statistical methods.

## 9. Report

9.1 The report shall include the following information:

9.1.1 The Scleroscope hardness number, and

9.1.2 The test conditions (method of support) and the type of Scleroscope instrument used.

## 10. Precision

10.1 The precision of this method has not been established due to the wide variety of materials tested by this method and the possible variations in test specimens. The accepted practice is to utilize the information in 8.1 when establishing hardness tolerances for specific applications. The precision of this method, whether involving a single operator, multiple operators or multiple laboratories, can be established by employing statistical methods.



## **B. VERIFICATION OF SCLEROSCOPE HARDNESS INSTRUMENTS**

### **11. Scope**

11.1 Part B covers the procedure for the verification of Scleroscope hardness instruments by a standardized test block method.

### **12. General Requirements**

12.1 Before a Scleroscope hardness instrument is verified, the instrument shall be examined to ensure that:

12.1.1 The instrument has been properly set up and leveled in a clamping stand resting on a vibration-free support. Hardness verifications shall only be made on test blocks with the Scleroscope mounted in a clamping stand. Under no circumstances shall hardness verifications be made on test blocks with the Scleroscope mounted in the swing arm and post, the roll-testing stand, or with the scleroscope held free-hand.

12.1.2 The diamond is free from cracks or flaws which would lead to incorrect readings.

12.1.3 The instrument is clean and the hammer is free from any foreign matter.

### **13. Verification by Standardized Test Blocks**

13.1 Check the Scleroscope hardness instrument by making a series of tests on standardized test blocks that cover the range of hardness of the materials to be tested.

13.2 Make five tests on each of the four sides of the block. Make tests no closer than 1/2 in. (13 mm) from the ends of the blocks and no closer than 1/4 in. (6 mm) from the sides of the blocks.

13.3 Consider the Scleroscope hardness instrument verified if 90 % of the Scleroscope readings taken on the test blocks deviate no more than  $\pm 3$  Scleroscope points from the mean of the spread in Scleroscope hardness numbers marked on the blocks.

### **14. Procedure for Periodic Checks by the User**

14.1 Verification by the standardized test block method (Section 13) is too lengthy for daily use. Instead the following procedure is recommended:

14.2 Make at least one routine check each day that the instrument is used.

14.3 Make at least five hardness readings on a standardized hardness test block at the hardness level at which the machine is being used. If the values fall within the range of the standardized hardness test block the instrument may be regarded as satisfactory; if not the machine should be verified as described in 13.2.

## **C. CALIBRATION OF STANDARDIZED HARDNESS TEST BLOCKS FOR SCLEROSCOPE HARDNESS INSTRUMENT**

### **15. Scope**

15.1 Part C covers the calibration of standardized hardness test blocks used for the verification of Scleroscope hardness instruments.

### **16. Manufacture**

16.1 Each test block to be calibrated shall be of steel with dimensions not less than 1 by 1 by 3 in. (25 by 25 by 76 mm) and the opposite sides shall be parallel.

16.2 Each block shall be specially prepared and heat treated to give a specific hardness and the necessary homogeneity and stability of structure.

16.3 The surfaces of the four sides of the block shall have a ground finish and shall be free from scratches which would influence the hardness reading.

16.4 The mean surface roughness height rating of the surface of each of the four sides shall not exceed 12  $\mu$ m. (300 nm), centerline average.

### **17. Standardizing Procedure**

17.1 Determine the hardness value of the test block by using a Scleroscope instrument of accepted accuracy mounted in the clamping stand (see item (a) 4.5).

17.2 Make five randomly distributed hardness determinations on each of the four sides of the test block.

17.3 Take the arithmetic mean of the twenty readings as the mean hardness of the block.

### **18. Uniformity of Hardness**

18.1 Unless 90 % of the twenty Scleroscope readings taken on the test block deviate no more than  $\pm 2$  Scleroscope points from the mean hardness (see section 16.3), the block cannot be regarded as sufficiently uniform for standardization purposes.

### **19. Marking**

19.1 Each block shall be marked on the end with the following:

19.1.1 One hardness number below and one hardness number above the arithmetic mean of the hardness values found in the standardizing test,

19.1.2 The letters HS or HFRSc or HFRSd, as appropriate, to designate the type of instrument to be standardized (Note 3), and

NOTE 3—Test blocks for Scleroscope hardness numbers HSc and HSd are identical.

19.1.3 The name or mark of the supplier.

### **20. Keywords**

20.1 metallic; scleroscope hardness

**NOTICE: This standard has either been superseded and replaced by a new version or discontinued. Contact ASTM International ([www.astm.org](http://www.astm.org)) for the latest information.**



*ASTM International takes no position respecting the validity of any patent rights asserted in connection with any item mentioned in this standard. Users of this standard are expressly advised that determination of the validity of any such patent rights, and the risk of infringement of such rights, are entirely their own responsibility.*

*This standard is subject to revision at any time by the responsible technical committee and must be reviewed every five years and if not revised, either reapproved or withdrawn. Your comments are invited either for revision of this standard or for additional standards and should be addressed to ASTM International Headquarters. Your comments will receive careful consideration at a meeting of the responsible technical committee, which you may attend. If you feel that your comments have not received a fair hearing you should make your views known to the ASTM Committee on Standards, at the address shown below.*

*This standard is copyrighted by ASTM International, 100 Barr Harbor Drive, PO Box C700, West Conshohocken, PA 19428-2959, United States. Individual reprints (single or multiple copies) of this standard may be obtained by contacting ASTM at the above address or at 610-832-9585 (phone), 610-832-9555 (fax), or [service@astm.org](mailto:service@astm.org) (e-mail); or through the ASTM website ([www.astm.org](http://www.astm.org)).*