



Standard Test Methods for Determining the Inclusion Content of Steel¹

This standard is issued under the fixed designation E 45; the number immediately following the designation indicates the year of original adoption or, in the case of revision, the year of last revision. A number in parentheses indicates the year of last reapproval. A superscript epsilon (ϵ) indicates an editorial change since the last revision or reapproval.

This standard has been approved for use by agencies of the Department of Defense.

1. Scope

1.1 These test methods cover a number of recognized methods for determining the nonmetallic inclusion content of wrought steel. Macroscopical methods include macroetch, fracture, step-down, and magnetic particle tests. Microscopical methods include five generally accepted systems of examination. In these microscopical methods, inclusions are assigned to a category based on similarities in morphology, and not necessarily on their chemical identity. Metallographic techniques that allow simple differentiation between morphologically similar inclusions are briefly discussed. While the methods are primarily intended for rating inclusions, constituents such as carbides, nitrides, carbonitrides, borides, and intermetallic phases may be rated using some of the microscopical methods. In some cases, alloys other than steels may be rated using one or more of these methods; the methods will be described in terms of their use on steels.

1.2 These test methods are suitable for manual rating of inclusion content. Other ASTM standards cover automatic methods for obtaining JK ratings (Practice E 1122) and inclusion content using image analysis (Practice E 1245).

1.3 Depending on the type of steel and the properties required, either a macroscopical or a microscopical method for determining the inclusion content, or combinations of the two methods, may be found most satisfactory.

1.4 These test methods deal only with recommended test methods and nothing in them should be construed as defining or establishing limits of acceptability for any grade of steel.

1.5 *This standard does not purport to address all of the safety concerns, if any, associated with its use. It is the responsibility of the user of this standard to establish appropriate safety and health practices and determine the applicability of regulatory limitations prior to use.*

2. Referenced Documents

2.1 ASTM Standards:

- A 295 Specification for High-Carbon Anti-Friction Bearing Steel²
 - A 485 Specification for High Hardenability Anti-Friction Bearing Steel²
 - A 534 Specification for Carburizing Steels for Anti-Friction Bearings²
 - A 535 Specification for Special-Quality Ball and Roller Bearing Steel²
 - A 756 Specification for Stainless Anti-Friction Bearing Steel²
 - A 866 Specification for Medium Carbon for Anti-Friction Bearing Steel²
 - D 96 Test Method for Water and Sediment in Crude Oil by Centrifuge Method (Field Procedure)³
 - E 3 Guide for Preparation of Metallographic Specimens⁴
 - E 7 Terminology Relating to Metallography⁴
 - E 381 Method of Macroetch Testing Steel Bars, Billets, Blooms, and Forgings⁴
 - E 709 Guide for Magnetic Particle Examination⁵
 - E 768 Practice for Preparing and Evaluating Specimens for Automatic Inclusion Assessment of Steel⁴
 - E 1122 Practice for Obtaining JK Inclusion Ratings Using Automatic Image Analysis⁴
 - E 1245 Practice for Determining Inclusion or Second-Phase Constituent Content of Metals by Automatic Image Analysis⁴
- #### 2.2 SAE Standards:⁶
- J421, Cleanliness Rating of Steels by the Magnetic Particle Method
 - J422, Recommended Practice for Determination of Inclusions in Steel
- #### 2.3 Aerospace Material Specifications:
- 2300, Premium Aircraft-Quality Steel Cleanliness: Magnetic Particle Inspection Procedure
 - 2301, Aircraft Quality Steel Cleanliness: Magnetic Particle

¹ This practice is under the jurisdiction of ASTM Committee E04 on Metallography and is the direct responsibility of Subcommittee E04.09 on Inclusions.

Current edition approved Apr. 10, 1997. Published June 1997. Originally published as E 45 – 42 T. Last previous edition E 45 – 97 ϵ ².

² Annual Book of ASTM Standards, Vol 01.05.

³ Annual Book of ASTM Standards, Vol 05.01.

⁴ Annual Book of ASTM Standards, Vol 03.01.

⁵ Annual Book of ASTM Standards, Vol 03.03.

⁶ Available from the Society of Automotive Engineers, 400 Commonwealth Drive, Warrendale, PA 15096.

Inspection Procedure⁶

2303, Aircraft Quality Steel Cleanliness: Martensitic Corrosion-Resistant Steels Magnetic Particle Inspection Procedure

2304, Special Aircraft-Quality Steel Cleanliness: Magnetic Particle Inspection Procedure

2.4 *ISO Standards:*

ISO 3763, Wrought steels—Macroscopic methods for assessing the content of nonmetallic inclusions

ISO 4967, Steel—Determination of content of nonmetallic inclusions—Micrographic methods using standard diagrams

2.5 *ASTM Adjuncts:*

Inclusions in Steel Plates I-r and II⁷

Four Photomicrographs of Low Carbon Steel⁸

3. Terminology

3.1 *Definitions:*

3.1.1 For definitions of terms used in this practice, see Terminology E 7.

3.1.2 Terminology E 7 includes the term *inclusion count*; since some methods of these test methods involve length measurements or conversions to numerical representations of lengths or counts, or both, the term *inclusion rating* is preferred.

3.2 *Definitions of Terms Specific to This Standard:*

3.2.1 *aspect ratio*—the length-to-width ratio of a microstructural feature.

3.2.2 *discontinuous stringer*—three or more Type B or C inclusions aligned in a plane parallel to the hot working axis and offset by no more than 15 μm , with a separation of less than 40 μm (0.0016 in.) between any two nearest neighbor inclusions.

3.2.3 *inclusion types*—for definitions of sulfide-, alumina-, and silicate-type inclusions, see Terminology E 7. Globular oxide, in some methods refers to isolated, relatively nondeformed inclusions with an aspect ratio not in excess of 5:1. In other methods, oxides are divided into deformable and nondeformable types.

3.2.4 *JK inclusion rating*—a method of measuring nonmetallic inclusions based on the Swedish Jernkontoret procedures; Methods A and D of these test methods are the principal JK rating methods, and Method E also uses the JK rating charts.

3.2.5 *stringer*—an individual inclusion that is highly elongated in the deformation direction or three or more Type B or C inclusions aligned in a plane parallel to the hot working axis and offset by no more than 15 μm , with a separation of less than 40 μm (0.0016 in.) between any two nearest neighbor inclusions.

3.2.6 *worst-field rating*—a rating in which the specimen is rated for each type of inclusion by assigning the value for the highest severity rating observed of that inclusion type anywhere on the specimen surface.

4. Significance and Use

4.1 These test methods cover four macroscopical and five microscopical test methods for describing the inclusion content of steel and procedures for expressing test results.

4.2 Inclusions are characterized by size, shape, concentration, and distribution rather than chemical composition. Although compositions are not identified, microscopical methods place inclusions into one of several composition-related categories (sulfides, oxides, and silicates—the last as a type of oxide). Paragraph 12.2.6 describes a metallographic technique to facilitate inclusion discrimination. Only those inclusions present at the test surface can be detected.

4.3 The macroscopical test methods evaluate larger surface areas than microscopical test methods and because examination is visual or at low magnifications, these methods are best suited for detecting larger inclusions. Macroscopical methods are not suitable for detecting inclusions smaller than about 0.40 mm ($1/64$ in.) in length and the methods do not discriminate inclusions by type.

4.4 The microscopical test methods are employed to characterize inclusions that form as a result of deoxidation or due to limited solubility in solid steel (indigenous inclusions). These inclusions are characterized by morphological type, that is, by size, shape, concentration, and distribution, but not specifically by composition. The microscopical methods are not intended for assessing the content of exogenous inclusions (those from entrapped slag or refractories) nor for rating the content of carbides, carbonitrides, nitrides, borides, or intermetallic phases, although they are sometimes used for this latter purpose.

4.5 Because the inclusion population within a given lot of steel varies with position, the lot must be statistically sampled in order to assess its inclusion content. The degree of sampling must be adequate for the lot size and its specific characteristics. Materials with very low inclusion contents may be more accurately rated by automatic image analysis (see Practice E 1122), which permits more precise microscopical ratings.

4.6 Results of macroscopical and microscopical test methods may be used to qualify material for shipment, but these test methods do not provide guidelines for acceptance or rejection purposes. Qualification criteria for assessing the data developed by these methods can be found in ASTM product standards or may be described by purchaser-producer agreements.

4.7 These test methods are intended for use on wrought metallic structures. While a minimum level of deformation is not specified, the test methods are not suitable for use on cast structures or on lightly worked structures.

MACROSCOPICAL METHODS

5. Macroscopical Test Methods Overview

5.1 *Summary:*

5.1.1 *Macroetch Test*—The macroetch test is used to indicate inclusion content and distribution, usually in the cross section or transverse to the direction of rolling or forging. In some instances, longitudinal sections are also examined. Tests are prepared by cutting and machining a section through the desired area and etching with a suitable reagent. A solution of

⁷ Available from ASTM Headquarters. Order PCN ADJE004502.

⁸ Available from ASTM Headquarters. Order PCN ADJE004501.

one part hydrochloric acid and one part water at a temperature of 71 to 82°C (160 to 180°F) is widely used. As the name of this test implies, the etched surface is examined visually or at low magnification for inclusions. Details of this test are included in Method E 381. The nature of questionable indications should be verified by microscopical or other means of inspection.

5.1.1.1 Sulfides are revealed as pits when the standard etchant described in 5.1.1 is used.

5.1.1.2 Only large oxides are revealed by this test method.

5.1.2 *Fracture Test*—The fracture test is used to determine the presence and location of inclusions as shown on the fracture of hardened slices approximately 9 to 13 mm ($\frac{3}{8}$ to $\frac{1}{2}$ in.) thick. This test is used mostly for steels where it is possible to obtain a hardness of approximately 60 HRC and a fracture grain size of 7 or finer. Test specimens should not have excessive external indentations or notches that guide the fracture. It is desirable that fracture be in the longitudinal direction approximately across the center of the slice. The fractured surfaces are examined visually and at magnifications up to approximately ten diameters, and the length and distribution of inclusions is noted. Heat tinting, or *blueing*, will increase visibility of oxide stringers. ISO 3763 provides a chart method for fracture surface inclusion ratings. In some instances, indications as small as 0.40 mm ($\frac{1}{64}$ in.) in length are recorded.

5.1.3 *Step-Down Method*—The step-down test method is used to determine the presence of inclusions on machined surfaces of rolled or forged steel. The test sample is machined to specified diameters below the surface and surveyed for inclusions under good illumination with the unaided eye or with low magnification. In some instances, test samples are machined to smaller diameters for further examination after the original diameters are inspected. This test is essentially used to determine the presence of inclusions 3 mm ($\frac{1}{8}$ in.) in length and longer.

5.1.4 *Magnetic Particle Method*—The magnetic particle method is a variation of the step-down method for ferromagnetic materials in which the test sample is machined, magnetized, and magnetic powder is applied. Discontinuities as small as 0.40 mm ($\frac{1}{64}$ in.) in length create magnetic leakage fields that attract the magnetic powder, thereby outlining the inclusion. See Section 6 for a detailed procedure.

5.2 Advantages:

5.2.1 These test methods facilitate the examination of specimens with large surface areas. The larger inclusions in steel, which are the main concern in most cases, are not uniformly distributed and the spaces between them are relatively large, so that the chances of revealing them are better when larger specimens are examined.

5.2.2 Specimens for macroscopical examination may be quickly prepared by machining and grinding. A highly polished surface is not necessary. The macroscopical methods are sufficiently sensitive to reveal the larger inclusions.

5.3 Disadvantages:

5.3.1 These test methods do not distinguish among the different inclusion shapes.

5.3.2 They are not suitable for the detection of small globular inclusions or of chains of very fine elongated inclusions.

5.3.3 The magnetic particle method can lead to incorrect interpretation of microstructural features such as streaks of retained austenite, microsegregation, or carbides in certain alloys; this is particularly likely if high magnetization currents are employed.

6. Magnetic Particle Method—Details of Procedure

6.1 Test Specimens:

6.1.1 The specimens shall be prepared in accordance with the details given in 6.2. The recommended procedure for removal from blooms, billets, and bars in round or square sections is as follows:

6.1.1.1 *Cross Sections over 230 cm² (36 in.²)*—Cut a quarter section as shown in Fig. 1 or 2 and prepare the specimen by machining, or forging and machining, to a straight cylinder of a diameter between 60 and 150 mm ($2\frac{1}{2}$ and 6 in.). An alternative method is to forge or roll the full section to 150 mm (6 in.) square or round and machine the quarter section in accordance with 6.1.1.2.

6.1.1.2 *Cross Sections 100 to 230 cm² (16 to 36 in.²) Inclusive*—Cut a quarter section as shown in Fig. 1 or Fig. 2 and prepare the specimen by machining, or forging and machining, to a straight cylinder of the largest possible diameter.

6.1.1.3 *Cross Sections Less than 100 cm² (16 in.²)*—Machine the specimen to a straight cylinder. An alternative method is to use a three diameter step-down specimen, each cylindrical section being 75 mm (3 in.) in length. The diameter, D, of the first step is the stock size less standard machining allowance; the diameter of the second step is $\frac{3}{4}$ D; and the diameter of the third step is $\frac{1}{2}$ D.

6.1.2 The specimens shall conform to the following requirements unless specified otherwise in 6.1.1.1-6.1.1.3:

6.1.2.1 The length of the rated surface is nominally 125 mm (5 in.). A 25 mm (1 in.) extension for holding is usually employed.

6.1.2.2 The minimum amount of stock removed from the surface shall be as follows:

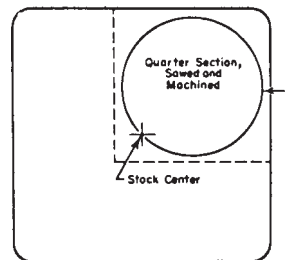

NOTE 1—This method is also applicable to round sections.

NOTE 2—*a* denotes surface removal.

FIG. 1 Quarter Section Specimen from Square Section for Magnetic Particle Test, Machine Only

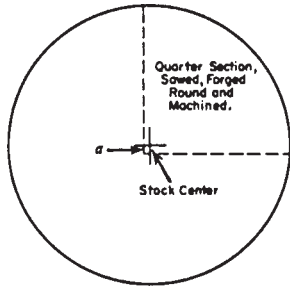

NOTE 1—Method also applicable to square sections.
 NOTE 2—*a* denotes distance equal to surface removal.

FIG. 2 Quarter Section Specimen from Round Section for Magnetic Particle Test, Forging and Machining

Nominal Stock Size, Round or Square, mm, (in.)	Minimum Stock Removal from the Surface, mm (in.)
To 12.7 (½)	0.76 (0.030)
Over 12.7 to 19 (½ to ¾)	1.13 (0.045)
Over 19 to 25.4 (¾ to 1)	1.52 (0.060)
Over 25.4 to 38 (1 to 1½)	1.89 (0.075)
Over 38 to 51 (1½ to 2)	2.28 (0.090)
Over 51 to 64 (2 to 2½)	3.17 (0.125)
Over 64 to 89 (2½ to 3½)	3.96 (0.156)
Over 89 to 115 (3½ to 4½)	4.75 (0.187)
Over 115 to 152 (4½ to 6)	6.35 (0.250)

6.1.2.3 All quarter sections shall be cut oversize as shown in Fig. 1 and Fig. 2 so that the center of the original stock will be approximately on the surface of the test specimen. The location of the center of the original stock shall be identified on the test specimen by means of a stamped mark.

6.2 Preparation of Specimen:

6.2.1 After the specimen is rough turned, heat treat it to a hardness of about 300 HB by oil or water quenching from well above the critical temperature and temper within the range 200 to 650°C (400 to 1200°F), depending upon the composition of the steel. Take care to avoid quenching cracks. The heat treatment tends to develop a more uniform structure hard enough to retain some residual magnetism, thus helping to hold the magnetic powder in place after the test.

6.2.2 After heat treatment, grind the specimen, including the ends, or otherwise clean to ensure good contact for magnetizing. Avoid cracks in the grinding checks. The grinding shall be transverse to the length of the specimen. Longitudinal scratches may be deep enough to retain the magnetic powder and obscure the inclusion determination.

6.2.3 Before magnetizing, thoroughly wash the specimen with a quick-drying solvent in order to remove grease and finger marks.

6.3 Procedure:

6.3.1 Circularly magnetize the specimen by passing direct current through it in the longitudinal direction for ½ to 1½ s. The magnitude of the current shall be 160 A/cm to 470 A/cm (400 to 1200 A/in.) of the diameter of the specimen.

6.3.2 In general, use the wet continuous method where the specimen is covered with magnetic particle suspension during magnetization. Hardened steel specimens (50 HRC or higher) may be tested using the wet residual method by applying the suspension after magnetization. Take care not to disturb indications before inspection is completed. For a detailed

description of the various wet methods of magnetic particle inspection, see Practice E 709.

6.3.3 It is common practice to suspend the fine magnetic particles in kerosene or other light oil of about 40 SUS viscosity. Use about 7.7 g/L (1 oz/gal) of nonfluorescent magnetic particles per litre of oil. The suspension concentration of nonfluorescent particles shall be 1.0 to 2.0 % by volume when tested by demagnetizing and allowing to settle 30 to 45 min in an ASTM 100-mL cone-shaped graduated centrifuge tube. For a description of a cone-shaped centrifuge tube, see Test Methods D 96.

6.3.4 As an alternative to the oil-base system, an aqueous system can be used. When using an aqueous system, the evaporation rate should be monitored. Add water to maintain the proper level.

6.4 Examination of Specimen:

6.4.1 Examine the specimen under a well-diffused light. Standard white fluorescent lighting is satisfactory. In order to obtain the best dispersion, place the longitudinal axis of the light at right angles to the longitudinal axis of the specimen. The larger inclusions will be plainly visible and the relatively small inclusions may also be detected. If inclusions of 0.8 mm (½ in.) or smaller are of interest, it will be helpful to examine with a low-power hand magnifying glass. The magnetic powder indications produced by inclusions can be distinguished by an experienced operator from indications due to other causes such as cracks, flow lines, carbides, etc. Record the size of each indication appearing on the surface of the specimen.

6.4.2 The indications representing inclusions may be recorded by photography, diagrams, or by transferring to a receptor medium. For example, a solution of plastic coating material may be applied by aerosol or other means, then removed and mounted after drying. Specially prepared absorbent papers such as dye transfer (imbibition) papers or *clean out films* may also be used successfully. These products are available in various sizes and may be obtained from photographic supply houses. Ordinary transparent adhesive tapes will also lift the magnetic powder from the specimen for mounting on a card. The transfer methods are rapid, sufficiently accurate to provide indications suitable for examination under low-power magnification, and are more accurate than photography on curved surfaces. Additionally, the transfer methods maintain the locations of indications in the specimen with respect to the original surface and centerline of the material.

6.5 Expression of Results:

6.5.1 Magnetic particle test results are normally expressed in terms of frequency and severity.

6.5.2 Frequency is the total number of indications in a given area. A commonly used reference area has been 258 cm² (40 in.²). Frequency may also be expressed in terms of number of indications per unit area of surface examined. The method of evaluating inclusions per square inch for frequency and severity has been adopted by the Society of Automotive Engineers in SAE J41. Refer to Aerospace Materials Specifications 2300, 2301, 2303, and 2304.

6.5.3 Severity is the weighted value of the magnetic particle indications in accordance with the following table taken from AMS specifications 2300, 2301, 2303, and 2304.

From AMS 2300 and 2304 Length of Indication, mm (in.)	Progression Factor for Severity Rating
0.4 to 0.8 ($\frac{1}{64}$ to $\frac{1}{32}$) exclusive	2
0.8 to 1.6 ($\frac{1}{32}$ to $\frac{1}{16}$) exclusive	4
1.6 to 3.2 ($\frac{1}{16}$ to $\frac{1}{8}$) exclusive	16
3.2 ($\frac{1}{8}$) and over	256
From AMS 2301 and 2303 Length of Indication, mm (in.)	Progression Factor for Severity Rating
1.6 to 3.2 ($\frac{1}{16}$ to $\frac{1}{8}$) inclusive	0.5
3.2 to 6.4 ($\frac{1}{8}$ to $\frac{1}{4}$) inclusive	1
6.4 to 12.8 ($\frac{1}{4}$ to $\frac{1}{2}$) inclusive	2
12.8 to 19 ($\frac{1}{2}$ to $\frac{3}{4}$) inclusive	4
19 to 25.4 ($\frac{3}{4}$ to 1) inclusive	8
over 25.40 to 38.10 (over 1 to 1- $\frac{1}{2}$) inclusive	16

6.5.3.1 The severity value is obtained by multiplying the number of indications of a given length by the weight factor and adding these results. Severity should be expressed as the weighted value for a given area. Severity may also be expressed as the weighted value per unit area of surface examined (see AMS Specifications 2300, 2301, 2303, and 2304).

6.5.4 The averages of the frequency and severity values for all the specimens in a heat may be used to express the magnetic particle results for the heat.

6.5.5 The frequency and severity values for one heat may be readily compared with the values of another heat. In making such comparisons between heats, however, exercise care to compare results obtained only on billets or bars of approximately the same size.

6.5.6 If a step-down test is used, results should be related to the individual diameters.

6.5.7 Magnetic particle results may also be expressed as the total length of indications for a stated area. In the AMS standards described above, inclusion length per square inch is determined.

MICROSCOPICAL METHODS

7. Microscopical Test Methods Overview

7.1 Microscopical methods are used to characterize the size, distribution, number, and type of inclusions on a polished specimen surface. This may be done by examining the specimen with a light microscope and reporting the types of inclusions encountered, accompanied by a few representative photomicrographs. This method, however, does not lend itself to a uniform reporting style. Therefore, standard reference charts depicting a series of typical inclusion configurations (size, type, and number) were created for direct comparison with the microscopical field of view.

7.2 Various reference charts of this nature have been devised such as the JK chart⁹ and the SAE chart found in SAE Recommended Practice J 422 of the SAE Handbook. The microscopical methods in Test Methods E 45 use refined comparison charts based on these charts. Method A (Worst Fields), Method D (Low Inclusion Content) and Method E (SAM Rating) use charts based on the JK chart while Method

C (Oxides and Silicates) uses the SAE chart. ISO Standard 4967 also uses the JK chart.

7.3 No chart can represent all of the various types and forms of inclusions. The use of any chart is thus limited to determining the content of the most common types of inclusions, and it must be kept in mind that such a determination is not a complete metallographic study of inclusions.

7.4 An alternate to comparison (chart) methods such as Methods A, C and D¹⁰ may be found in Method B. Method B (Length) is used to determine inclusion content based on length. Only inclusions 0.127 mm (0.005 in.) or longer are recorded regardless of their type. From this method one may obtain data such as length of the longest inclusion and average inclusion length. In addition, photomicrographs may also be taken to characterize the so called *background inclusions* that were not long enough to measure.

7.5 The advantages of the microscopical methods are:

7.5.1 Inclusions can be characterized as to their size, type, and number.

7.5.2 Extremely small inclusions can be revealed.

7.6 A disadvantage of the microscopical methods is that individual rating fields are very small (0.50 mm²). This limits the practical size of the specimen as it would simply take a prohibitive number of fields to characterize a large specimen. The result obtained by a microscopical characterization of the inclusions in a large section is governed by chance if local variations in the inclusion distribution are substantial. The end use of the product determines the importance of the microscopical results. Experience in interpreting these results is necessary in order not to exaggerate the importance of small inclusions in some applications.

7.7 In determining the inclusion content, it is important to realize that, whatever method is used, the result actually applies only to the areas of the specimens that were examined. For practical reasons, such specimens are relatively small compared with the total amount of steel represented by them. For the inclusion determination to have any value, adequate sampling is just as necessary as a proper method of testing.

7.8 Steel often differs in inclusion content not only from heat to heat, but also from ingot to ingot in the same heat and even in different portions of the same ingot. It is essential that the unit lot of steel, the inclusion content of which is to be determined, shall not be larger than one heat. Sufficient samples should be selected to represent the lot adequately. The exact sampling procedure should be incorporated in the individual product requirements or specifications. For semifinished products, the specimens should be selected after the material has been sufficiently cropped and suitable discards made. If the locations of the different ingots and portions of ingots in the heat cannot be identified in the lot being tested, random sampling should involve a greater number of test specimens for an equivalent weight of steel. A value for the inclusion content

⁹ The JK chart derives its name from its sponsors Jernkontoret, the Swedish Ironmasters Association.

¹⁰ Note that while these methods are called comparison chart methods, the procedure used may also consist of length measurements or counts of inclusions, or both.

of an isolated piece of steel, even if accurately determined, should not be expected to represent the inclusion content of the whole heat.

7.9 The size and shape of the wrought steel product tested has a marked influence on the size and shape of the inclusions. During reduction from the cast shape by rolling or forging, the inclusions are elongated and broken up according to the degree of reduction of the steel cross section. In reporting results of inclusion determinations, therefore, the size, shape, and method of manufacture of the steel from which the specimens were cut must be stated. In comparing the inclusion content of different steels, they must all be rolled or forged as nearly as possible to the same size and shape, and from cast sections of about the same size. Specimens cut lengthwise or parallel to the direction of rolling or forging shall be used.

7.10 It may be convenient, in order to obtain more readily comparable results, to forge coupons from larger billets. These forged sections may then be sampled in the same way as rolled sections. Exercise care, however, to crop specimens of sufficient length from the billets for forging; otherwise, there is danger of the shear-dragged ends being incorporated in the specimens. Such distorted material will give a false result in the inclusion determination. To avoid this, it is helpful to saw the ends of the billet length for forging and to take the specimen from the middle of the forged length.

7.11 Several of the methods described in these test methods require that a specific area of the prepared surface of the specimen be surveyed, and all the significant inclusions observed be recorded and expressed in the results. The reported result for each specimen examined is, therefore, a more accurate representation of the inclusion content than a photomicrograph or diagram. A disadvantage of the Worst Field approach is that no such distribution of inclusion ratings is obtained.

7.12 To make comparisons possible between different heats and different parts of heats, the results shall be expressed in such a manner that an average for the inclusion content of the different specimens in the heat can be obtained. When the lengths of the inclusions are measured, the simplest number is that for the aggregate length of all the inclusions per area examined; however, it may be desirable not merely to add the lengths but also to weight the inclusions according to their individual lengths. The length of the largest inclusion found and the total number of inclusions may also be expressed.

8. Sampling

8.1 To obtain a reasonable estimate of inclusion variations within a lot, at least six locations, chosen to be as representative of the lot as possible, should be examined. In this context, a lot shall be defined as a unit of material processed at one time and subjected to similar processing variables. In no case should more than one heat be in the same lot. For example if a lot consists of one heat, sampling locations might be in the product obtained from the top and bottom of the first, middle, and last usable ingots in the pouring sequence. For strand cast or bottom pour processing, a similar sampling plan per heat should be invoked.

8.2 For cases in which a definite location within a heat, ingot, or other unit lot is unknown, statistical random sampling with a greater number of specimens should be employed.

8.3 Ratings obtained will vary with the amount of reduction of the product. For materials acceptance or for comparison among heats, care must be taken to sample at the correct stage of processing.

9. Test Specimen Geometry

9.1 The recommended polished surface area of a specimen for the microscopical determination of inclusion content is 160 mm² (0.25 in.²). The polished surface must be parallel to the longitudinal axis of the product. In addition, for flat-rolled products, the section shall also be perpendicular to the rolling plane; for rounds and tubular shapes, the section shall be in the radial direction.

9.2 *Thick Section (Product Section Size Greater than 9.5 mm (0.375 in.) Thick, Such as Forgings, Billet, Bar, Slab, Plate, and Pipe):*

9.2.1 For wide products, the one-quarter point along the product width is commonly used to provide representative material.

9.2.2 For round sections, the manner of cutting a specimen from a 38 mm (1.5-in.) diameter section is shown in Fig. 3. A disk about 9.5 mm (0.375 in.) thick is cut from the product. The quarter-section indicated in Fig. 3 is cut from the disk and the shaded area is polished. Thus the specimen extends 9.5 mm along the length of the product from the outside to the center.

9.2.3 For large sections, each specimen shall be taken from the mid-radius location, as shown by the shaded area in Fig. 4. The specimen face to be polished extends 9.5 mm parallel to the longitudinal axis of the billet and 19 mm (0.75 in.) in the longitudinal radial plane, with the polished face midway between the center and the outside of the billet. Such midway sampling is used to decrease the number of specimens polished and examined. Other areas, such as the center and the surface, may be examined as well, provided the sampling procedure used is stated in the results. A billet or bar about 50 to 100 mm (2 to 4 in.) round or square is the preferred size from which

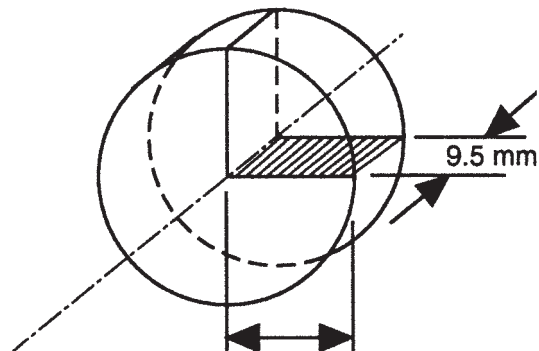

NOTE 1—Inch-pound equivalents: 9.5 mm = 3/8 in.; 19 mm = 3/4 in.
FIG. 3 Specimen from 1½ -in. (38.1 mm) Round Section for Microscopical Test

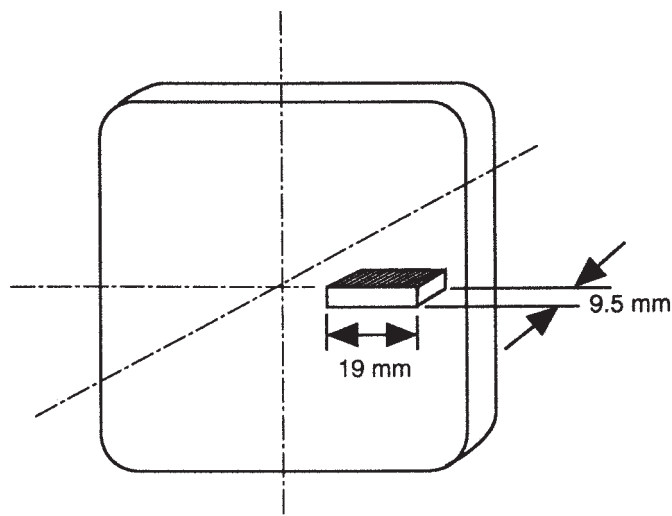

FIG. 4 Specimen from Large Bar or Billet for Microscopical Test

specimens should be taken; however, larger or smaller sizes may be used, provided the product sizes are reported with the results.

9.3 *Thin Sections (Product Section Sizes 9.5 mm (0.375 in.) Thick or Less; Strip, Sheet, Rod, Wire, and Tubing)*—Full cross section longitudinal specimens shall be cut in accordance with the following plan:

9.3.1 For 0.95 to 9.5-mm (0.0375 to 0.375 in.) cross section thicknesses inclusively, a sufficient number of pieces from the same sampling point are mounted to provide approximately 160 mm² (0.25 in.²) of polished specimen surface. (Example: For a sheet 1.27 mm (0.050 in.) thick, select seven or eight longitudinal pieces uniformly across the sheet width to provide one specimen).

9.3.2 For cross section thicknesses less than 0.95 mm, ten longitudinal pieces from each sampling location shall be mounted to provide a suitable specimen surface for polishing. (Dependent on material thickness and piece length, the polished specimen area may be less than 160 mm². Because of practical difficulties in mounting a group of more than ten pieces, the reduced specimen area will be considered sufficient.) Note that when using the comparison procedures of Methods A, C, D and E, the thickness of the test specimen cross section should not be less than the defined minimum dimension of a single field of view. Therefore, the minimum thickness required is 0.71 mm for Methods A, D, and E, and 0.79 mm for Method C. Thinner sections should be rated by other means.

10. Preparation of Specimens

10.1 Methods of specimen preparation must be such that a polished, microscopically flat section is achieved in order that the sizes and shapes of inclusions are accurately shown. To obtain satisfactory and consistent inclusion ratings, the specimen must have a polished surface free of artifacts such as pitting, foreign material (for example, polishing media), and scratches. When polishing the specimen it is very important that the inclusions not be pitted, dragged, or obscured. Specimens must be examined in the as-polished condition, free from

the effects of any prior etching (if used). It is recommended that the procedures described in Guide E 3 and Practice E 768 be followed.

10.2 If the conditions for inclusion evaluation stated in 10.1 cannot be met in the as-polished condition with the as-received sample, the sample shall be heat-treated to the maximum attainable hardness before polishing. Necessary precautions shall be taken to eliminate the effects of heat treatment such as scale, decarburization, etc. This practice is recommended for heat-treatable grades of carbon, low alloy, and stainless steels.

11. Precision and Bias

11.1 Studies of JK ratings made by different laboratories have shown that there is an inherent problem in inclusion identification, chiefly in discrimination between Type A (sulfides) and C (silicate) deformable oxide inclusions. Hence, the accuracy of JK ratings can be severely influenced by such problems. The accuracy of Method A, C, and D ratings is influenced by total inclusion contents. As the inclusion content increases, the accuracy of such ratings decreases.

11.2 For steels that are rated to 0.5 Severity Level Numbers on Plate I-r, worst field ratings are generally accurate within ± 1 severity number and may be within ± 0.5 severity at low inclusion content. In general, the accuracies of rating of Type B and D inclusions are better than for Type A and C inclusions. Also, the accuracy of the thin series is generally better than for the Heavy series, regardless of the inclusion type.

11.3 For steels that must be rated to whole Severity Level Numbers using Plate I-r, the accuracies are generally poorer, approaching ± 2 at the highest severity levels. The same trends apply here regarding A and C versus B and D Types and Thin versus Heavy. Greater inaccuracies will occur if inclusions are misidentified. The accuracy of inclusion field counts using Method D is not as good as for the worst field ratings. A good, accurate Method D rating requires considerable effort.

11.4 The accuracy of Method C ratings is significantly influenced by misidentification of S Type (deformable oxide) inclusions. When such problems are not encountered, steels with low inclusion contents will agree within ± 1 unit, while steels with high inclusion contents will agree within ± 2 units of severity. Method C, Plate II, is only used to rate oxides, never sulfides.

11.5 The precision of ratings made by the use of Plate I-r generally agrees with the chart severity increments used but may in certain cases be slightly higher. For very low inclusion content steels, automatic image analysis methods (as covered by Practices E 1122 and E 1245) are preferable where ratings below the minimum rating ($\frac{1}{2}$) are possible. Note that microscopical Methods A and D stipulate minimum sizes for *rateable* inclusions; thus a field or a specimen may contain inclusions that are identifiable but not rateable because they are below the minimum size for a non-zero rating.

12. Method A (Worst Fields)¹¹

12.1 *Introduction*—This test method requires a survey of a 160 mm² (0.25 in.²) polished surface area of the specimen at

¹¹ This method is similar to the Jernkontoret Method, Uppsala, Sweden (1936).

100×. The field size shall equal an area equivalent to 0.50 mm² (0.000779 in.²) on the specimen surface as defined by a square with 0.71 mm (0.02791 in.) long sides (See Fig. 5). Each 0.50 mm² field is compared to the square fields depicted in Plate I-r in a search for the worst field, that is, the highest severity rating, of each inclusion Type A, B, C, and D for both the *Thin* and *Heavy* series. The severity level of these worst fields shall be reported for every specimen examined.

12.2 Procedure:

12.2.1 Either of two techniques may be employed to achieve a 0.50 mm² square field of view. One method is to project the 100× microscope image onto a viewing screen that has a square mask with 71.0 mm (2.79 in.) sides drawn on it. Another option is to use a reticle made for the microscope which will superimpose the required square mask directly onto the field of view. (See Fig. 5).

12.2.2 To begin, outline the required test area on the specimen surface using either an indelible marker or a carbide-tipped scribe. Place the specimen on the microscope stage and start the examination with a field in one of the corners of the marked test area. Compare this field to the images on Plate I-r. Record the severity level in whole numbers from 0 to 3.0 for each inclusion type (A, B, C, and D) that most resembles the field under observation. (See Table 1 if required to report severity levels > 3.0). Do this for both the Thin and Heavy series. It is important to note here that if a field of inclusions falls between two severity levels, its value is rounded down to the lower severity level. For example, when using Plate I-r, a field that contains fewer inclusions, or less inclusion length than Severity Level Number 1, is counted as a 0.

TABLE 1 Minimum for Severity Level Numbers (Methods A, D, and E)^{A,B}

Severity Level	Total Length in One Field at 100X, min, mm (in.)			Number of Inclusions in One Field, min
	Type A	Type B	Type C	
1/2	3.7 (0.15)	1.7 (0.07)	1.8 (0.07)	1
1	12.7 (0.50)	7.7 (0.30)	7.6 (0.30)	4
1 1/2	26.1 (1.03)	18.4 (0.72)	17.6 (0.69)	9
2	43.6 (1.72)	34.3 (1.35)	32.0 (1.26)	16
2 1/2	64.9 (2.56)	55.5 (2.19)	51.0 (2.01)	25
3	89.8 (3.54)	82.2 (3.24)	74.6 (2.94)	36
3 1/2	118.1 (4.65)	114.7 (4.52)	102.9 (4.05)	49
4	149.8 (5.90)	153.0 (6.02)	135.9 (5.35)	64
4 1/2	189.8 (7.47)	197.3 (7.77)	173.7 (6.84)	81
5	223.0 (8.78)	247.6 (9.75)	216.3 (8.52)	100

^ANote that length values in this table have been changed to be compatible with automated rating methods. The significant length changes occurred at minimum rating levels of 1/2 where manual methods are least accurate. Inclusion counts for Type D inclusions have also been revised. In this case, the changes are greatest for high counts, which are above the levels of material acceptance standards.

^BVanderVoort, G. F., and Wilson, R. K., "Nonmetallic Inclusions and ASTM Committee E-4," *Standardization News*, Vol 19, May 1991, pp 28–37.

^CMaximum aspect ratio for Type D inclusions is 5:1.

12.2.3 Move the microscope stage to reveal an adjacent field and repeat the comparison procedure. Continue this process until the required polished surface area of the specimen has been scanned. A typical scan configuration is shown in Fig. 6. This method requires adjustment of the microscope stage to maximize an inclusion severity level. That is, the field of view is adjusted using the microscope stage controls, such that inclusions are moved inside the square mask in order to locate the *worst field*. In practice, the rater is actually scanning the

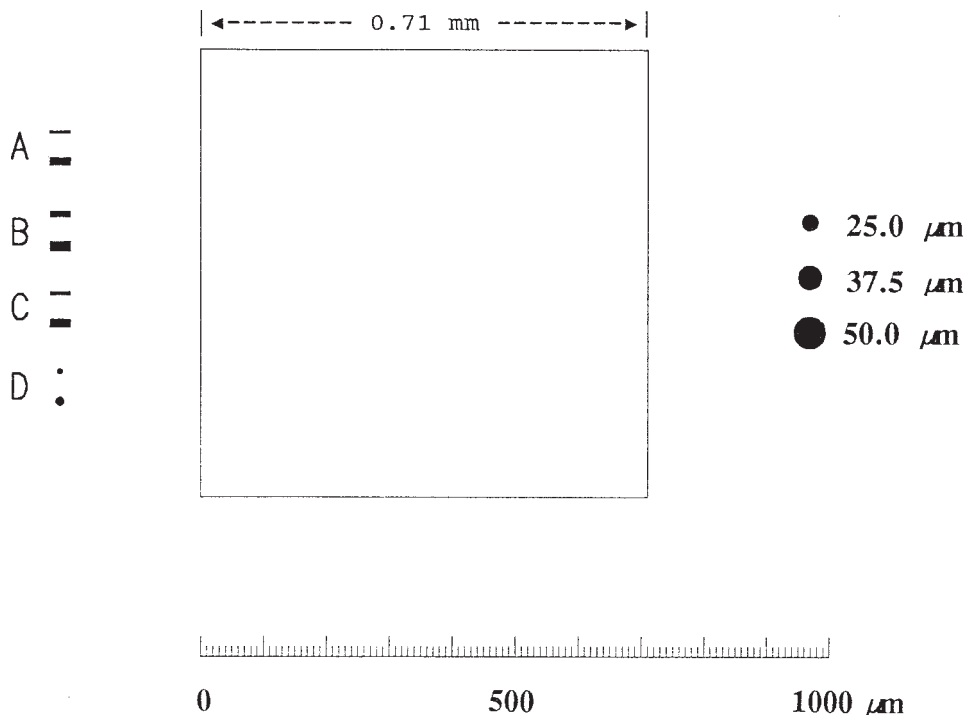

NOTE 1—The square mask will yield a field area of 0.50 mm² on the specimen surface. A graphic representation of the maximum thickness of the Thin and Heavy series of Types A, B, C, and D is on the left. Several oversized Type D are depicted on the right for convenience.

FIG. 5 Suggested Reticle or Overlay Grid For Methods A, D, and E

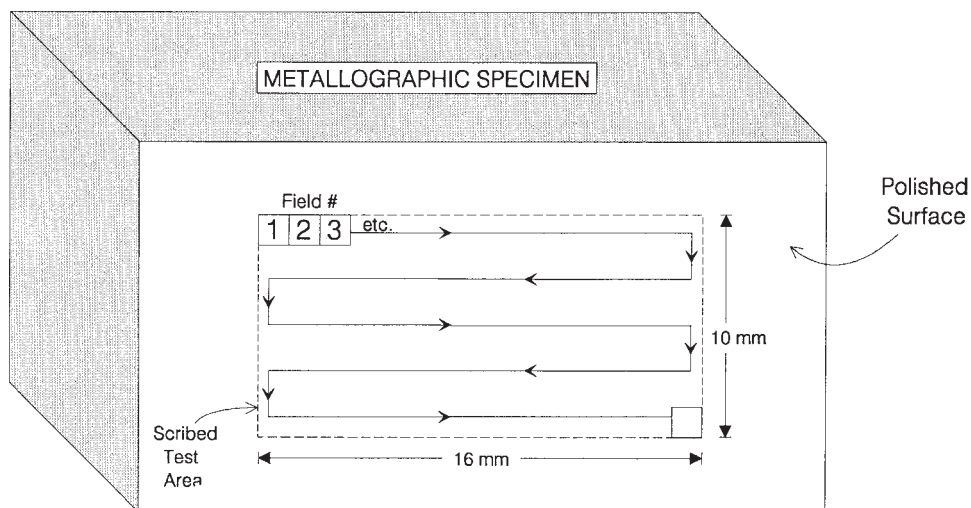

NOTE 1—Systematically scan the entire masked area. Methods A, B, C, and E permit adjustment of the field locations in order to maximize a severity level number or facilitate a measurement. For Method D, the fields must remain contiguous and only features within the field are compared to Plate I-r.

NOTE 2—Method D will require a larger (10 × 17 mm) test area to facilitate placement of enough contiguous, 0.71 mm square fields to total 160 mm² of polished surface area.

FIG. 6 Typical Scan Pattern for Microscopical Methods

specimen and stopping only when a potential *worst field* of each type and thickness is in view.

12.2.4 The minimum inclusion lengths (or numbers for Type D only) that determine the Severity Level Numbers are printed on Plate I-r and listed in Table 1. Inclusion width parameters for classification into the Thin or Heavy category are listed in Table 2. An inclusion whose width varies from Thin to Heavy along its length shall be placed in the category that best represents its whole. That is to say, if more than half its length falls into the *Heavy* range, classify it as Heavy. See 12.3.2 for instructions on reporting inclusions that exceed the limits of Table 1 and Table 2.

12.2.5 Although Method A was originally designed to rate inclusions in whole numbers, various standards (Specifications A 295, A 485, A 534, A 535, A 756, and A 866) permit rating to ½ Severity Level Numbers. This practice is permissible. (See 15.2.2.)

12.2.6 The typical chemical types of inclusions listed at the top of Plate I-r for Categories A, B, C, and D are not meant to suggest that knowledge of inclusion composition is necessary. In this method, inclusions are assigned to a category based on similarities in morphology and not on their chemical identity. Type A (sulfide) and Type C (silicate) inclusions are very similar in size and shape. Therefore, discrimination between

these types should be aided by metallographic techniques, such as viewing the questionable inclusions with darkfield illumination (or cross polarizers) where properly polished sulfide inclusions are dark and silicate inclusions appear luminescent. A second technique is to note the hue of the inclusions; sulfides are generally light gray and silicates are very dark or sometimes glassy in appearance. This test method may be used to rate non-traditional types of inclusions based on their size and shape; that is, sulfides that have been subjected to shape, control treatments, or encapsulated oxides. In addition, borides, carbides, nitrides, or the like may also be rated. It is required, however, that the results clearly reflect that other than the traditional types of nonmetallic inclusions, as depicted on Plate I-r, have been rated.

12.2.7 Classify discontinuous-type stringer inclusions of Types B or C as two distinct inclusions when they are separated by at least 40 μm (0.0016 in.) (or offset by more than 15 μm) on the specimen surface. If two or more inclusions of the same type (A, B, or C) appear in one microscope field, their summed length determines the Severity Level Number. Usually, direct comparison with Plate I-r will establish the severity levels without the necessity for measurements.

12.3 Expression of Results:

12.3.1 The averages of the worst fields for each inclusion type in all the specimens of the lot shall be calculated in accordance with the Severity Level Numbers given at the sides of Plate I-r or Table 1. An example showing the averages obtained for six specimens examined is given in Table 3.

12.3.2 The fields shown in Plate I-r represent the total lengths of the A inclusions, the total stringer lengths of B and C inclusions, the number of D inclusions, and their respective limiting widths or diameters. If any inclusions are present that are longer than the fields shown in Plate I-r, their lengths shall be recorded separately. If their widths or diameters are greater than the limiting values shown in Plate I-r and Table 2, they

TABLE 2 Inclusion Width and Diameter Parameters (Methods A and D)^A

Inclusion Type	Thin Series		Heavy Series	
	Width, min, μm	Width, max, μm	Width, min, μm	Width, max, μm
A	2	4	>4	12
B	2	9	>9	15
C	2	5	>5	12
D	2	8	>8	13

^AAny inclusion with maximum dimensions greater than the maximum for the Heavy Series must be reported as *oversized* accompanied with its actual dimensions.

**TABLE 3 Worst-Field Inclusion Ratings (Method A)
Severity Levels^A**

Specimen	Type A		Type B		Type C		Type D	
	Thin	Heavy	Thin	Heavy	Thin	Heavy	Thin	Heavy
1	2	1	2	1	1	0	2	1
2	3	1	2	1	0	1	2	2
3	2	1	2	1	0	0	2	2
4	2	1	2	1	1	0	2	1
5	2	1	2	1	0	1	2	1
6	3	1	2	1	0	0	2	1
Average	2.3	1.0	2.0	1.0	0.3	0.3	2.0	1.3

^ASee 12.3.1.

shall be recorded separately. Note that an oversize A, B, or C inclusion or inclusion stringer still contributes to the determination of a field's Severity Level Number. Therefore, if an A, B, or C inclusion is oversized either in length or thickness that portion that is within the field boundaries shall be included in the appropriate Thin or Heavy severity level measurement. Likewise, if an oversize D inclusion is encountered in a field, it is also included in the count that determines the D heavy rating. For reference, illustrations of large, globular oxides appear at the bottom of Plate I-r. A Type D globular oxide may not exceed an aspect ratio of 5:1.

12.3.3 If desired, the predominant chemical type of inclusions may be determined and recorded as sulfide, silicate, or oxide. If the charts are used to rate carbides or nitrides, chemical composition information may also be determined and reported.

13. Method B (Length)

13.1 *Introduction*—This test method requires a survey of a 160 mm² polished surface area of the specimen at 100×. Any inclusion whose length is 0.127 mm or longer is to be measured and individually tallied.

13.2 Procedure:

13.2.1 This method utilizes a pattern of parallel lines whose spacing is such that the distance between lines is equivalent to 0.127 mm (0.005 in.) on the specimen surface when viewed at 100×. This distance shall be referred to as one unit. The pattern may be drawn on (or taped to) a viewing screen, in which case the physical distance between lines would be 12.7 mm (0.5 in.) since the specimen is magnified 100 times. An alternate technique would be to have a reticle made that will superimpose the required pattern directly onto the image as seen through the eyepieces of the microscope. Fig. 7 shows a recommended measurement grid for use with Method B. Note that the parallel lines are contained in a mask to aid in the indexing of fields.

13.2.2 To begin, outline the required test area on the specimen surface using either an indelible marker or a carbide-tipped scribe. Place the specimen on the microscope and start the examination with a field in one of the corners of the marked test area. Measure and record all inclusions in this field that are one unit long or longer. Inclusions separated by a distance greater than one unit shall be classified as two inclusions and not be considered as one stringer. The length of an inclusion shall be rounded down to the next whole unit and only whole units will be recorded. For example, if an inclusion measures

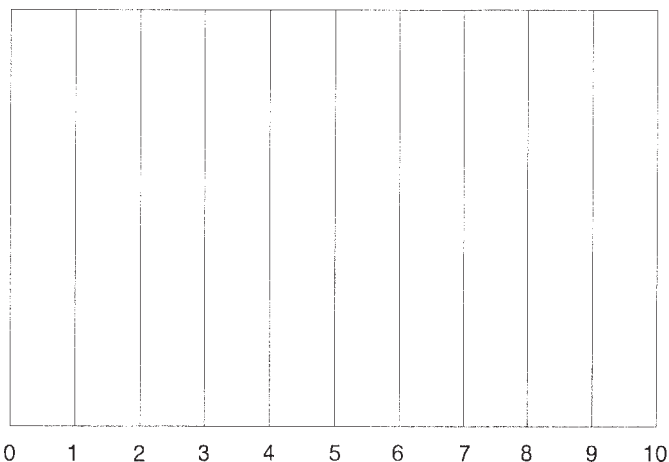

NOTE 1—One unit equals 0.127 mm (0.005 in.) on the specimen surface.

FIG. 7 Suggested Reticle or Overlay Grid for Method B

2½ units, it shall be recorded as a “2.” If an inclusion lies partially outside of the field, that is, part of its length lies in what will become Field Number 2, move the field slightly in order that its entire length may be measured.

13.2.3 Move the microscope stage to view an adjacent field. Repeat the measurement procedure. Take care that any inclusion measured in the previous field is not remeasured. Continue this process until the required polished surface area of the specimen has been scanned. A typical scan configuration is shown in Fig. 6.

13.3 Expression of Results:

13.3.1 The determination for each specimen shall be divided into two parts, as follows:

13.3.1.1 The length of the longest inclusion shall be recorded first. It shall be supplemented to describe the inclusion width by a superscript T for thin or H for heavy. A thin inclusion is defined as being 10 μm (0.0004 in.) or less in width over more than 50 % of its entire length. Likewise, a heavy inclusion must have a thickness of 30 μm (0.012 in.) or more over the majority of its length. Inclusions greater than 10 μm but less than 30 μm wide shall not be represented by a T or H superscript. Superscripts *d* (disconnected), *vd* (very disconnected), and *g* (grouped) may also be used to describe the degree of connectivity or clustering as illustrated in Fig. 8.

13.3.1.2 The average length of all inclusions one unit and longer in length, but excluding the longest inclusion, shall be reported as a single number, followed by a superscript denoting the number of inclusions averaged.

13.3.2 When required, a series of comparison photomicrographs at 100X, which illustrates all other nonmetallic particles present, may be used to characterize the background appearance of the specimen. If used, these shall be labeled A, B, ... etc., in order of increasing inclusion population. The specific photomicrographs used shall be mutually agreed upon between the interested parties.¹²

¹² A series of four photomicrographs of low carbon steel, previously printed as part of Practice E 45, may be obtained from ASTM Headquarters. Order PCN 12-500454-01.

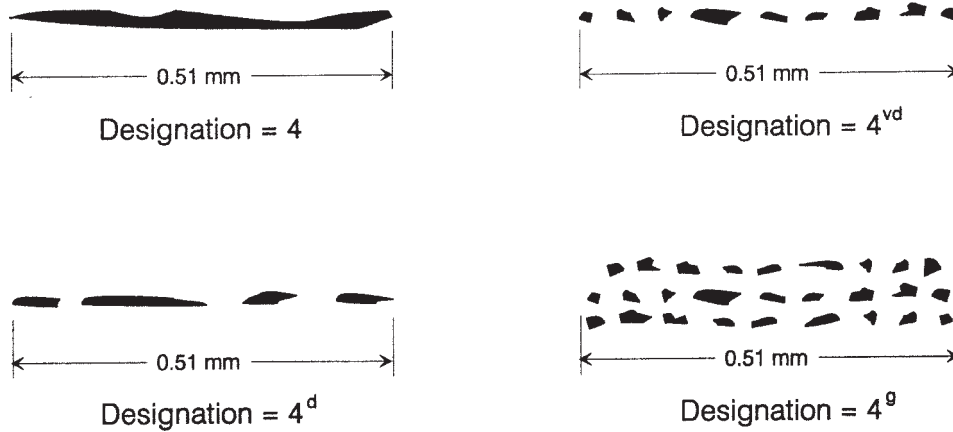

NOTE 1—d = disconnected, vd = very disconnected, and g = grouped.
 NOTE 2—0.51 mm = 0.02 in.

FIG. 8 Designation of Length and Weight of Inclusions (4 Units Long)

13.3.3 The following is an expression of results for a single specimen by this method: 6^d-2^3-A . This indicates that the longest inclusion observed was six units long, that three other inclusions were observed whose average length was two units, and that the background inclusions were similar in appearance to the A figure from a background photomicrographic series.

13.3.4 The results for all specimens from a lot shall be tabulated. If required, the predominant type of inclusions (sulfides, silicates, or oxides) shall be recorded.

14. Method C (Oxides & Silicates)¹³

14.1 *Introduction*—This method requires a survey of a 160 mm² polished surface area of the specimen at 100×. Each field on the specimen shall be examined for the presence of non-deformable alumina oxide and deformable silicate stringers and rated by comparison to Plate II. The longest stringer of each inclusion type (“O” for alumina oxides and “S” for silicates) shall be reported, per the designations of Plate II, for every specimen examined. Note that sulfides are not rated by this method.

14.2 Procedure:

14.2.1 This method utilizes a rectangular mask that will present a field area of 0.83 mm² (0.001289 in.²) on the specimen surface. The rectangular mask shall have sides equal to 0.79 × 1.05 mm (0.03125 × 0.04125 in.) on the specimen surface (see Fig. 9).

14.2.2 Either of two techniques may be used to mask off a field of the required size. One method is to project the 100× image from the microscope to a viewing screen equipped with a rectangular mask having sides 79.0 × 105.0 mm. Another option is to have a reticle made for the microscope which will superimpose the required rectangular mask directly onto the field of view.

14.2.3 To begin, outline the required test area on the specimen surface using either an indelible marker or a carbide-tipped scribe. Place the specimen on the microscope and start the examination with a field in one of the corners of the marked

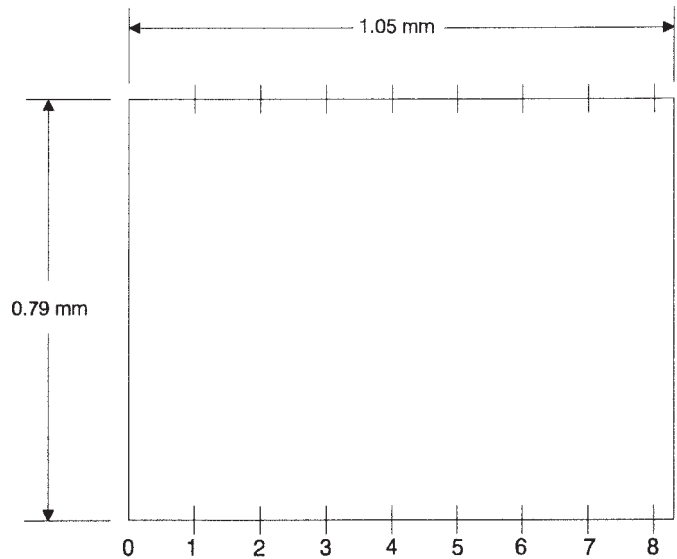

NOTE 1—One unit equals 0.127 mm (0.005 in.) on the specimen surface. Dimensions equal actual distance on the specimen surface and will yield a field area of 0.83 mm².

FIG. 9 Suggested Reticle or Overlay Grid for Method C

test area. The longer side of the rectangular mask shall be parallel to the rolling direction. Compare this field with the images on Plate II and record the number of the frame that most resembles the oxide or silicate stringers, or both, present. It is important to note that if an inclusion’s size falls between two of the numbered frames on Plate II, it shall be rounded down to the lower whole number. Also, stringered inclusions shall be classified as two distinct inclusions when they are separated by at least 40 μm (0.0016 in.) on the specimen surface or offset by more than 15 μm.

14.2.4 Move the microscope stage to reveal an adjacent field and repeat the comparison procedure with Plate II. Continue this process until the required polished surface area of the specimen has been scanned. A typical scan configuration is shown in Fig. 6. It is permissible, and will be necessary at times, to adjust the microscope stage such that the entire

¹³ This method is similar to SAE Recommended Practice J422.

stringer may be viewed within the mask. The rater's objective is to find the longest oxide and silicate stringers in the specimen. Therefore, in practice, the rater is actually scanning the specimen and stopping only when a potential *longest stringer* is in view.

14.3 Expression of Results:

14.3.1 The maximum length of each type of inclusion, usually a series of individual particles in a stringer, is generally used to evaluate a specimen. The silicate photomicrographs are used for deformable-oxide inclusions, and the oxide photomicrographs for all non-deformable oxide, or hard-type, inclusions. For example, a specimen may be classified 0-5 (oxide) and S-4 (silicate) to indicate that the longest non-deformable oxide inclusion seen was comparable to Oxide Photomicrograph 5, and the longest deformable-oxide inclusion seen was comparable to Silicate Photomicrograph 4.

14.3.2 Modifications, such as suffix numerals, may be used to indicate the number of long inclusions noted or the exact length of a particular inclusion when it is over the maximum length indicated by the photomicrographs.

15. Method D (Low Inclusion Content)

15.1 *Introduction*—This test method is intended for application to steels with low inclusion contents as the severity levels shall be reported in ½ increments. It requires a survey of a 160 mm² polished surface area of the specimen at 100×. Every square 0.50 mm² (0.000779 in.²) field on the polished surface is examined for inclusion Types A, B, C, and D and compared with the square fields depicted on Plate I-r. The result of this *every field* comparison is recorded and tallied.

15.2 Procedure:

15.2.1 A field shall be defined as a square with 0.71 mm (0.02791 in.) long sides. See Fig. 5. This will result in a field area of 0.50 mm² on the specimen. Either of two techniques may be employed to achieve the square field. One method is to project the 100× microscope image onto a viewing screen that has a square mask (with 71.0 mm sides) drawn on it. Another option is to have a reticle made for the microscope, which will superimpose the required square mask directly onto the field of view (see Fig. 5).

15.2.2 To begin, outline the required test area on the specimen surface using either an indelible marker or a carbide-tipped scribe. Place the specimen on the microscope and start the examination with a field in one of the corners of the specimen. Compare this field with the images on Plate I-r. Record the Severity Level Number for each inclusion type (A, B, C, and D) that most resembles the field under observation. Do this for both the Thin and Heavy series. It is important to note that if a field of inclusions falls between two severity levels it is rounded down to the nearest severity level. Therefore, a field that contains fewer inclusions, or less inclusion length, than severity level ½ is recorded as a 0.

15.2.3 Move the microscope stage to reveal an adjacent field and repeat the comparison procedure with Plate I-r. The fields shall be contiguous and only inclusions or portions of inclusions that fall within the square mask shall be considered. It is not acceptable practice to move an inclusion into the square field simply to prevent its intersection with the sides of the mask. Continue this process until the required polished surface

area of the specimen has been rated. A typical scan configuration is shown in Fig. 6.

15.2.4 The typical chemical types of inclusions listed at the top of Plate I-r for Categories A, B, C, and D are for convenience only and do not mandate knowledge of the inclusion composition. In this method, inclusions are assigned to a category based on similarities in morphology and not on their chemical identity. Type A (sulfide) and Type C (silicate) inclusions are very similar in size and shape. Therefore, discrimination between these types should be aided by metallographic techniques, such as viewing the questionable inclusions with darkfield illumination (or crossed polarizers) where properly polished sulfide inclusions are dark and silicate inclusions appear luminescent. A second technique is to note the hue of the inclusions: sulfides are generally light gray, and silicates are very dark or sometimes glassy in appearance. This test method may be used to rate non-traditional types of inclusions based on their size and shape; for example, sulfides that have been subjected to shape control treatments or encapsulated oxides. In addition, borides, carbides, nitrides, or the like may also be rated. It is required, however, that the results clearly reflect that other than the traditional types of non-metallic inclusions, as depicted on Plate I-r, have been rated.

15.2.5 In contrast with Method A, this is an *every field* rating method. The arbitrary field boundaries created by stepwise movement through the sample should not be altered or adjusted. Record the severity level shown on the side of Plate I-r selected for each inclusion type (A, B, C, or D) that appears most like the field under observation for both the thin and heavy series. Report each field containing inclusions equivalent to or greater than the 0.5 severity level. See Table 1 for values of Severity Level Numbers >3.0.

15.2.6 Type A, B, or C inclusions that are wider than those depicted in the heavy series of Plate I-r (or listed in Table 2) shall be noted and recorded separately. However, their lengths still contribute to the overall severity rating for the field in which they occur. Likewise, note that the size of the D Heavy inclusions shown in Plate I-r is maintained at 0.013 mm (0.0005 in.). Record separately, with their actual measured sizes any globular oxides larger than the size illustrated in the heavy series depicted in Plate I-r. These *oversized* inclusions must also be considered when determining the Type D Heavy Severity Level Number for the field in which they occur. For reference, illustrations of large, globular oxides appear at the bottom of the Type D column in Plate I-r. A Type D globular oxide may not exceed an aspect ratio of 5:1.

15.2.7 The minimum inclusion lengths (or numbers for Type D only) that determine the inclusion rating numbers are printed on Plate I-r and listed in Table 1.

15.2.8 Classify broken stringered inclusions of Type B or C as two distinct inclusions when they are separated by at least 40 μm (0.0016 in.) or offset by more than 15 μm on the specimen surface.

15.2.9 Inclusion width parameters for classification into the Thin or Heavy categories are listed in Table 2. An inclusion whose width varies from Thin to Heavy along its length shall

be placed in the category that best represents its whole. That is, if most of it falls into the *Heavy* range classify it as *Heavy*.

15.2.10 If two or more stringered inclusions of the same type (A, B, or C) appear in one microscope field, their summed length determines the inclusion rating number. Direct comparison with Plate I-r might establish the inclusion rating number without the necessity for measurements.

15.2.11 Table 3 shows the inclusion width ranges utilized in Plate I-r. The minimum resolvable width for the thin inclusions rated at 100× is 2 μm.

15.3 Expression of Results:

15.3.1 The number of fields of each inclusion type (A, B, C, and D of Plate I-r) found for both the thin and heavy series

shall be recorded for each specimen in terms of the Severity Level Numbers 0.5 to 3.0.

15.3.2 If any field or inclusion is found that exceeds the limits of severity level 3.0 (displayed on Plate I-r and listed in Table 1), it shall be recorded separately. Likewise if the widths or diameters are greater than the limiting values shown on Plate I-r (and Table 2), these inclusions shall also be recorded separately.

15.3.3 To average the results of more than one specimen, the average of the number of fields found for each inclusion rating number and type in the various specimens examined within a lot may be calculated as illustrated in Table 4.

TABLE 4 Example of Inclusion Rating (Method D)

Severity Level Number		Number of Fields in Each Specimen Specimen Number						Average of Six Specimens	
		1	2	3	4	5	6	Thin	Heavy
Type A									
0.5	Thin	65	60	50	65	37	56	55.5	
	Heavy	9	8	12	6	16	8		9.8
1.0	Thin	19	15	31	8	12	10	15.8	
	Heavy	4	3	4	1	2	1		2.5
1.5	Thin	1	3	2	0	1	0	1.2	
	Heavy	0	0	0	0	0	0		0
2.0	Thin	1	0	0	0	0	0	0.2	
	Heavy	0	0	0	0	0	0		0
2.5	Thin	0	0	0	0	0	0	0	
	Heavy	0	0	0	0	0	0		0
Type B									
0.5	Thin	13	8	7	6	11	10	9.2	
	Heavy	0	0	0	1	1	0		0.3
1.0	Thin	13	14	10	6	12	12	11.2	
	Heavy	0	0	0	0	2	1		0.5
1.5	Thin	1	6	6	3	3	2	3.5	
	Heavy	0	0	0	0	0	0		0
2.0	Thin	0	2	1	0	1	1	0.8	
	Heavy	0	0	0	0	0	0		0
2.5	Thin	0	1	0	0	1	0	0.3	
	Heavy	0	1	0	0	0	0		0.2
Type C									
0.5	Thin	0	0	0	0	1	0	0.2	
	Heavy	0	0	0	0	0	0		0
1.0	Thin	0	0	0	0	0	0	0	
	Heavy	0	0	0	0	0	0		0
1.5	Thin	0	0	0	0	0	0	0	
	Heavy	0	0	0	0	0	0		0
2.0	Thin	0	0	0	0	0	0	0	
	Heavy	0	0	0	0	0	0		0
2.5	Thin	0	0	0	0	0	0	0	
	Heavy	0	0	0	0	0	1		0.2
Type D									
0.5	Thin	35	33	28	32	47	29	34.0	
	Heavy	9	4	5	6	9	9		7.0
1.0	Thin	13	10	20	9	12	41	17.5	
	Heavy	0	2	2	1	2	4		1.8
1.5	Thin	0	0	4	0	0	6	1.7	
	Heavy	0	0	0	0	0	0		0
2.0	Thin	0	0	0	0	0	0	0	
	Heavy	0	0	0	0	0	0		0
2.5	Thin	0	0	0	0	0	0	0	
	Heavy	0	0	0	0	0	0		0
Max D Size		0.0305 mm (0.0012 in.)		0.0254 mm (0.001 in.)		0.0254 mm (0.001 in.)			

15.3.4 If desired, the predominant chemical type of inclusions may be determined (using, for example, energy dispersive x-ray spectroscopy on a scanning electron microscope).

16. Method E (SAM Rating)

16.1 *Introduction*—This test method is used to rate the inclusion content of steels in a manner that reflects the severity and frequency of occurrence of the larger B- and D-Type inclusions. It will result in a survey of a 160 mm² polished surface of the specimen at 100×.

16.2 Procedure:

16.2.1 A field shall be defined as a square with 0.71 mm (0.02791 in.) long sides. See Fig. 5. This will result in a field area of 0.50 mm² on the specimen. Either of two techniques may be employed to achieve the square field. One method is to project the 100× microscope image onto a viewing screen that has a square mask (with 71.0 mm sides) drawn on it. Another option is to have a reticle made for the microscope which will superimpose the required square mask directly onto the field of view.

16.2.2 To begin, outline the required test area on the specimen surface using either an indelible marker or a carbide-tipped scribe. Place the specimen on the microscope and start the examination with a field in one of the corners of the marked test area. Compare this field with the images on Plate I-r. Rate only the B and D type inclusions using the following criteria.

16.2.3 A rating of B-type inclusions is obtained by comparing each field of the specimen with the fields in Plate I-r (Table 1 may also be used). Record all B-Thin fields observed at severity levels of 1.5 or higher and all B-Heavy fields observed at each severity level of 1.0 or higher. See Table 2 for width and diameter parameters. Classify a field with size of inclusions intermediate between configurations in Plate I-r or Table 1 as the lower inclusion rating. An inclusion whose width varies from Thin to Heavy along its length shall be placed in the category that best represents its whole.

16.2.4 Classify broken B-types as two distinct inclusions when they are separated by at least 40 μm (0.0016 in.) or offset by more than 15 μm on the specimen surface. If two or more B-types appear in one microscope field, their summed length determines the inclusion rating number.

16.2.5 When an A-type sulfide has formed a complex inclusion with either a B- or D-type oxide, the inclusion shall be rated as a B- or D-type provided its oxide volume is the predominant (>50 % by area) chemical type.

16.2.6 A rating of D-type inclusions is obtained by recording all D-Heavy fields with a rating of 0.5 or higher. See Table 2 for width and diameter parameters. Fields of 0.5 severity are counted as one unit; fields of 1.0 severity as two units; fields of 1.5 severity as three units; and so on. The minimum inclusion numbers for D-type are printed on Plate I-r and listed in Table 1.

16.2.7 Move the microscope stage to reveal an adjacent field and repeat the comparison procedure with Plate I-r. This method requires adjustment of the microscope stage in order to maximize the inclusion Severity Level Number. That is, the field of view is adjusted using the microscope stage controls such that inclusions are moved inside the square mask in order to determine the maximum severity of rateable B- and

D-Types. Continue this process, being careful not to rate any inclusion more than once, until the required polished surface area of the specimen has been rated. A typical scan configuration is shown in Fig. 6.

16.2.8 If any inclusions are present that are longer than the fields shown in Plate I-r, their lengths shall be recorded separately. If their widths or diameters are greater than the limiting values shown in Plate I-r and Table 2, they shall be recorded separately. Note that an oversize B or D inclusion still contributes to the determination of a field's Severity Level Number. Therefore, if a B inclusion is oversized either in length or thickness, that portion that is within the field boundaries shall be included in the appropriate Thin or Heavy severity level measurement. Likewise, if an oversize D inclusion is encountered in a field, it also is included in the count that determines the D heavy rating.

16.3 Expression of Results:

16.3.1 Results are expressed in terms of two rating numbers reflecting B-type and D-heavy type inclusion contents.

16.3.2 The number of B-type fields recorded at each severity level times the severity level is summed (see Table 5) and normalized by dividing by the total rated area, in square inches, of all samples. The nearest whole number is recorded as the rating.

16.3.3 The number of D units is summed (see Table 5) and normalized by dividing by the total rated area, in square inches, of all samples. The nearest whole number is recorded as the rating.

16.3.4 All oversized B- and D-Type inclusions are reported along with their actual lengths or widths, or both.

17. Test Report

17.1 Pertinent information regarding the origin and identity of the test specimen should be reported along with the data requirements covered in the "Expression of Results" section of each test method.

17.2 Report, also, the following information:

17.2.1 Date of test,

17.2.2 Rater's name,

17.2.3 Plant location,

17.2.4 Heat number; and

17.2.5 Specimen identification code and any other unique data (such as a lot number) that can provide traceability within the seller's organization.

TABLE 5 SAM Rating (Method E)

No. of Observed Fields	B-Type rating ^{A,B}		D-Type Rating ^{A,C}			Units
	"B" Thin	No. of Observed Fields	"B" Heavy	No. of Observed Fields	"D" Heavy	
not recorded	0.5	not recorded	0.5	5	0.5	(1)
not recorded	1.0	2	1.0	2	1.0	(2)
3	1.5	1	1.5	1	1.5	(3)
1	2.0	0	2.0	0	2.0	(4)
0	2.5	0	2.5	0	2.5	(5)

^ATotal area observed = 1.5 in.²

^BSAM rating = (3 × 1.5) + (1 × 2) + (2 × 1) + (1 × 1.5) = 10 ÷ 1.5 = 7.

^CSAM rating = (5 × 1) + (2 × 2) + (1 × 3) = 12 ÷ 1.5 = 8.

18. Keywords

rating; silicate; step-down method; stringer; sulfide

18.1 alumina; fracture test; inclusion rating; JK inclusion rating; macroetch test; magnetic-particle method; oxide; SAM

ASTM International takes no position respecting the validity of any patent rights asserted in connection with any item mentioned in this standard. Users of this standard are expressly advised that determination of the validity of any such patent rights, and the risk of infringement of such rights, are entirely their own responsibility.

This standard is subject to revision at any time by the responsible technical committee and must be reviewed every five years and if not revised, either reapproved or withdrawn. Your comments are invited either for revision of this standard or for additional standards and should be addressed to ASTM International Headquarters. Your comments will receive careful consideration at a meeting of the responsible technical committee, which you may attend. If you feel that your comments have not received a fair hearing you should make your views known to the ASTM Committee on Standards, at the address shown below.

This standard is copyrighted by ASTM International, 100 Barr Harbor Drive, PO Box C700, West Conshohocken, PA 19428-2959, United States. Individual reprints (single or multiple copies) of this standard may be obtained by contacting ASTM at the above address or at 610-832-9585 (phone), 610-832-9555 (fax), or service@astm.org (e-mail); or through the ASTM website (www.astm.org).