

This document is not an ASTM standard and is intended only to provide the user of an ASTM standard an indication of what changes have been made to the previous version. Because it may not be technically possible to adequately depict all changes accurately, ASTM recommends that users consult prior editions as appropriate. In all cases only the current version of the standard as published by ASTM is to be considered the official document.



Designation: E 213 – 024

## Standard Practice for Ultrasonic Examination of Metal Pipe and Tubing<sup>1</sup>

This standard is issued under the fixed designation E 213; the number immediately following the designation indicates the year of original adoption or, in the case of revision, the year of last revision. A number in parentheses indicates the year of last reapproval. A superscript epsilon ( $\epsilon$ ) indicates an editorial change since the last revision or reapproval.

---

<sup>1</sup> This practice is under the jurisdiction of ASTM Committee E07 on Nondestructive Testing and is the direct responsibility of Subcommittee E07.06 on Ultrasonic Method. Current edition approved June 10, 2002; January 1, 2004. Published August 2002; February 2004. Originally published as E 213 – 63 F, approved in 1963. Last previous edition E 213 – 98, approved in 2002 as E 213 - 02.

## 1. Scope

1.1 This practice<sup>2</sup> covers a procedure for detecting discontinuities in metal pipe and tubing during a volumetric examination using ultrasonic methods. Specific techniques of the ultrasonic method to which this practice applies include pulse-reflection techniques, both contact and non-contact (for example, as described in Guide E 1774), and angle beam immersion techniques. Artificial reflectors consisting of longitudinal, and, when specified by the using party or parties, transverse reference notches placed on the surfaces of a reference standard are employed as the primary means of standardizing the ultrasonic system.

1.2 This practice is intended for use with tubular products having outside diameters approximately ½ in. (12.7 mm) and larger, provided that the examination parameters comply with and satisfy the requirements of Section 12. These procedures have been successful with smaller sizes. These may be specified upon contractual agreement between the using parties. These procedures are intended to ensure that proper beam angles and beam shapes are used to provide full volume coverage of pipes and tubes, including those with low ratios of outside diameter-to-wall thickness, and to avoid spurious signal responses when examining small-diameter, thin-wall tubes.

1.3 The procedure in Annex A1 is applicable to pipe and tubing used in nuclear and other special and safety applications. The procedure in Annex A2 may be used to determine the helical scan pitch.

1.4 This practice does not establish acceptance criteria; they must be specified by the using party or parties.

1.5 The values stated in inch-pound units are to be regarded as standard. The SI equivalents are in parentheses brackets and may be approximate.

1.6 *This standard does not purport to address all of the safety concerns, if any, associated with its use. It is the responsibility of the user of this standard to establish appropriate safety and health practices and determine the applicability of regulatory limitations prior to use.*

## 2. Referenced Documents

### 2.1 ASTM Standards:<sup>3</sup>

E 543 Practice for Evaluating Agencies that Perform Nondestructive Testing

E 1065 Guide for Evaluating Characteristics of Ultrasonic Search Units

E 1316 Terminology for Nondestructive Examinations

E 1774 Guide for Electromagnetic Acoustic Transducers (EMATs)

E 1816 Practice for Ultrasonic Examinations Using Electromagnetic Acoustic Transducer (EMAT) Techniques

### 2.2 ASNT Documents:

Recommended Practice SNT-TC-1A for Nondestructive Testing Personnel Qualification and Certification<sup>4</sup>

ANSI/ASNT CP-189 Standard for Qualification and Certification of Nondestructive Testing Personnel<sup>4</sup>

### 2.3 Military Standards:

MIL-STD-410 Nondestructive Testing Personnel Qualification and Certification<sup>5</sup>

### 2.4 Aerospace Industries Association Document:

NAS 410 Certification and Qualification of Nondestructive Testing Personnel<sup>6</sup>

## 3. Terminology

3.1 *Definitions*—For definitions of terms used in this practice, see Terminology E 1316.

## 4. Summary of Practice

4.1 A pulsed ultrasonic angle beam by means of non-contact, surface contact or immersion method shall be used. Fig. 1 illustrates the characteristic ultrasonic angle beam entry into the wall of a pipe or tube in the circumferential direction to detect longitudinal discontinuities using a single search unit. Fig. 2 illustrates the characteristic angle beam ultrasound entry into the wall of a pipe or tube in the axial direction to search for transverse discontinuities using a single search unit.

NOTE 1—The immersion method may include tanks, wheel search units, or systems that use streams or columns of liquid to couple the ultrasonic energy from the search unit to the material.

4.2 To ensure detection of discontinuities that may not provide a favorable response from one side, scanning shall be performed in both circumferential directions for longitudinal discontinuities and when an axial scan is specified by the using party or parties, in both axial directions for transverse discontinuities.

4.3 For efficient examination of large quantities of material, multiple search units and instruments may be used simultaneously to perform scanning in the required directions. Multiple search units may be employed for “interlaced” scanning in each required direction to enable higher examination rates to be achieved through higher allowable scan index or “pitch.”

<sup>2</sup> For ASME Boiler and Pressure Vessel Code applications see related Practice SE-213 in the Code.

<sup>3</sup> For referenced ASTM standards, visit the ASTM website, [www.astm.org](http://www.astm.org), or contact ASTM Customer Service at [service@astm.org](mailto:service@astm.org). For Annual Book of ASTM Standards, Vol 03-03, Standards volume information, refer to the standard's Document Summary page on the ASTM website.

<sup>4</sup> Available from American Society for Nondestructive Testing, Inc., 1711 Arlingate Lane, Columbus, OH 43228.

<sup>5</sup> Available from Standardization Documents Order Desk, Bldg. 4 Section D, 700 Robbins Ave., Philadelphia, PA 19111-5094, Attn: NPODS.

<sup>6</sup> Available from Aerospace Industries Association of America, Inc., 1250 Eye St. NW, Washington D.C. 20005.

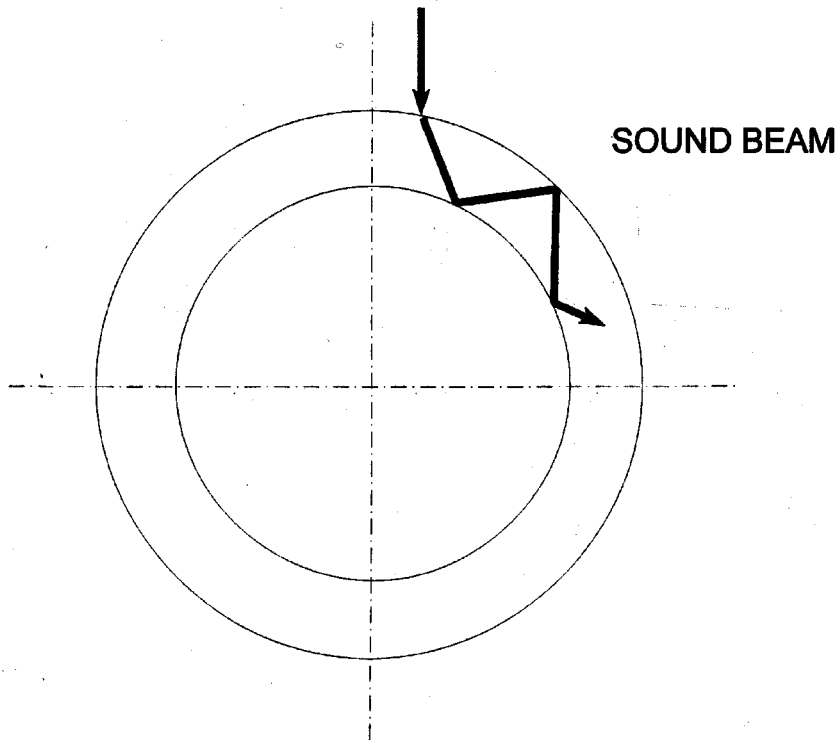

FIG. 1 Circumferential Propagation of Sound in a Pipe or Tube Wall

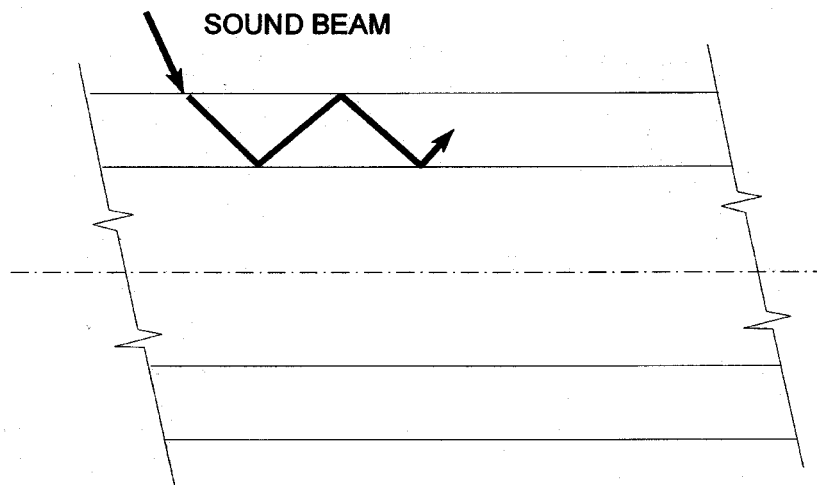

FIG. 2 Axial Propagation of Sound in a Pipe or Tube Wall

## 5. Significance and Use

5.1 The purpose of this practice is to outline a procedure for detecting and locating significant discontinuities such as pits, voids, inclusions, cracks, splits, etc., by the ultrasonic pulse-reflection method.

## 6. Basis of Application

6.1 The following are items that must be decided upon by the using party or parties.

6.1.1 Size and type of pipe or tubing to be examined,

6.1.2 Additional scanning for transverse discontinuities. At the discretion of the user, other auxiliary items discontinuities,

6.1.3 Items that affect examination coverage may also be specified such as ~~required~~ scan overlap, pulse density and maximum search unit size,;

6.1.34 The stage(s) in the manufacturing process at which the material will be examined,

6.1.45 Surface condition,

- 6.1.56 Maximum time interval between equipment standardization checks, if different from that described in 13.2 and the tolerance to be applied to a standardization check,
- 6.1.67 Type, dimensions, location, method of manufacture, and number of artificial reflectors to be placed on the reference standard,
- 6.1.78 Method(s) for measuring dimensions of artificial reflectors and tolerance limits if different than specified in Section 11,
- 6.1.89 Criteria for reportable and rejectable indications (acceptance criteria),
- 6.1.910 Reexamination of repaired/reworked items, if required or permitted, shall be specified in the contractual agreement.
- 6.1.101 Requirements for permanent records of the response from each tube, if applicable,
- 6.1.112 Contents of examination report,
- 6.1.123 Operator qualifications and certification, if required,
- 6.1.134 Qualification of Nondestructive Agencies. If specified in the contractual agreement, NDT agencies shall be qualified and evaluated as described in Practice E 543. The applicable edition of Practice E 543 shall be specified in the contractual agreement.
- 6.1.145 Level of personnel qualification. (See 7.1)

## 7. Personnel Qualification

7.1 If specified in the contractual agreement, personnel performing examinations to this standard shall be qualified in accordance with a nationally recognized NDT personnel qualification practice or standard such as ANSI/ASNT-CP-189, SNT-TC-1A, MIL STD-410, NAS-410, or a similar document and certified by the employer or certifying agency, as applicable. The practice or standard used and its applicable revision shall be identified in the contractual agreement between the using parties.

NOTE 2—MIL STD-410 is canceled and has been replaced with NAS-410, however, it may be used with agreement between contracting parties.

## 8. Surface Condition

8.1 All surfaces shall be clean and free of scale, dirt, grease, paint, or other foreign material that could interfere with interpretation of examination results. The methods used for cleaning and preparing the surfaces for ultrasonic examination shall not be detrimental to the base metal or the surface finish. Excessive surface roughness or scratches can produce signals that interfere with the examination.

## 9. Apparatus

9.1 Instruments shall be of the pulse echo type and shall be capable of detecting the reference notches of the types described in Section 11 to the extent required in the standardization procedure described in Section 12. An independent channel (or channels) of instrumentation shall be employed to individually monitor the responses from the longitudinal and, when required, transverse oriented search units. The instrument pulse repetition rate shall be capable of being adjusted to a sufficiently high value to ensure notch detection at the scanning rate employed. The instrument shall be capable of this pulse repetition rate without false indications due to spurious reflections or interference from other instruments and search units being used for simultaneous examinations in other directions or along other scan paths.

9.1.1 The frequency and bandwidth of the instrument and search unit shall be capable of being selected to produce a satisfactory signal-to-noise ratio for the detection of the required notches as compared to background ~~“noise”~~ “noise” response from irregularities such as grain boundaries and surface roughness.

9.2 Search unit frequency shall be selected to produce a desirable ~~“signal-to-noise”~~ “signal-to-noise” ratio (S/N), from the material to be examined, at the specified sensitivity. A S/N value of at least 3 to 1 is usually considered to be minimum. A higher minimum value is desirable and may be specified by the contracting agency.

9.2.1 Select a search unit size, frequency and refracted angle (or corresponding parameters for non-contact techniques) to produce an approximate 45 degrees beam-center shear wave in the tube or pipe wall. For material with an outside diameter-to-thickness ratio less than 7, a lower refracted angle (or corresponding parameters for non-contact techniques) must be used to ensure intersection with the inside surface. This does not ensure detection of midwall discontinuities [See Reference 5].

9.3 The positions of all conveyor and drive mechanisms must be set to support and feed the material to be examined in a stable manner and at the desired scan ~~“pitch”~~ “pitch” (helix). For small tubes, support mechanisms must be used in the examination station to prevent any transverse motion with respect to the search unit beam during scanning. If larger material that is not straight is to be examined the search units may have to be supported in a ~~“follower”~~ “follower” mechanism to compensate for this.

## 10. Couplant

10.1 For piezoelectric-based search units (non-contact techniques do not require couplant), a couplant such as water, oil, or glycerin, capable of conducting ultrasonic vibrations between the search unit and the pipe or tube being examined shall be used. Rust inhibitors, softeners, and wetting agents may be added to the couplant. The couplant liquid with all the additives should not be detrimental to the surface condition of the pipe or tube, and shall wet the surface of the material to provide adequate coupling efficiency. To prevent spurious signals or loss of sensitivity, or both, care must be taken to avoid the presence of air bubbles in the couplant.

NOTE 3—In the contact method, some couplants result in better ultrasonic transmission when the tubing is precoated several hours before the examination.

**11. Reference Standards**

11.1 A reference standard of a convenient length shall be prepared from a length of pipe or tube of the same nominal diameter, wall thickness, material, surface finish, and acoustical properties as the material to be examined. The reference pipe or tube shall be free of discontinuities or other conditions producing indications that can interfere with detection of the reference notches.

11.2 Longitudinal and, when required by the contracting agency, transverse reference notches shall be placed on both the outside and inside surfaces of the reference standard to ensure satisfactory examination sensitivity near each of these boundaries.

11.3 Reference notches shall be separated sufficiently (circumferentially or axially, or both) to preclude interference and interpretation difficulties.

11.4 All upset metal, burrs, etc., adjacent to the reference notches shall be removed.

11.5 The notch dimensions, which are length, depth, and width (and for V-notches, the included angle) must be decided upon by the using party or parties. Fig. 3 illustrates the common notch configurations and the dimensions to be measured (Note 4). Reflection amplitudes from V-, square-, and U-shaped notches of comparable dimensions may vary widely depending on the angle, frequency, and vibrational mode of the interrogating sound beam.

NOTE 4—In Fig. 3 (a), (b), and (d), the sharp corners are for ease of illustration. It is recognized that in normal machining practice, a radius will be generated.

11.5.1 The notch depth shall be an average measured from the circular tubing surface to the maximum and minimum penetration of the notch. Measurements may be made by optical, replicating, or other agreed upon techniques. Unless specified otherwise by the using party or parties, the notch depth shall be within  $\pm 0.0005$  in.  $\{ [0.013 \text{ mm}] \}$  of the specified value for notches 0.005 in.  $\{ [0.13 \text{ mm}] \}$  or less in depth, and within  $+ 10, - 15 \%$  of the specified value for notches over 0.005 in. in depth. At the option of the testing agency, shallower notches may be used to provide a more stringent examination.

NOTE 5—For as-rolled or scaly pipe or tube surfaces, it may be necessary to modify 11.5.1. Two acceptable modifications are listed below. Modification (a) is preferred; however, modification (b) may be used unless otherwise specified.

- (a) The circular pipe or tube surface may be smoothed or prepared in the notch area, or
- (b) The notch depth shall be within  $\pm 0.001$  in.  $\{ 0.025 \text{ mm} \}$ , or  $+ 10, - 15 \%$  of the specified depth, whichever is greater.
- (b) The notch depth shall be within  $\pm 0.001$  in.  $\{ 0.025 \text{ mm} \}$ , or  $+ 10, - 15 \%$  of the specified depth, whichever is greater.

11.5.2 When notch tolerances are specified by the using party or parties, tolerances may often include only negative values with zero positive deviation allowed so that sensitivity is never reduced below a specified minimum value. The use of smaller notches by the examination agency is permissible, provided that concurrence is obtained from the contracting agency.

NOTE 6—The amplitude of indications obtained from reference notches may not be linearly proportional to notch depth. This depends upon the intercepting beam width to notch length.

11.5.3 The width of the notches shall be as small as practical, but should not exceed twice the depth.

11.6 Other types and orientations of reference reflectors may be specified by the using party or parties.

**12. Standardization of Apparatus**

12.1 *Static Standardization*—Using the reference standard specified in Section 11, adjust the equipment to produce clearly

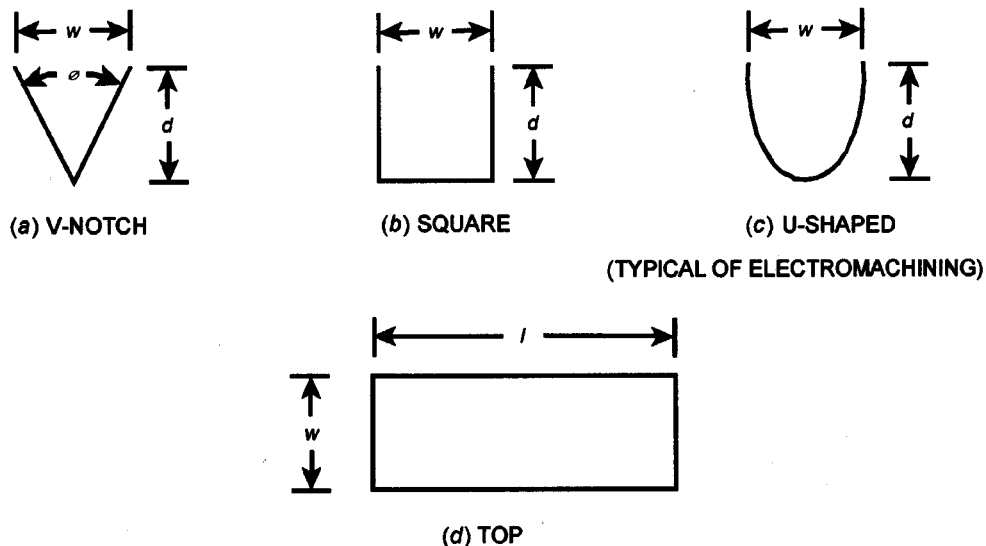

FIG. 3 Common Notch Shapes

identifiable indications from both the inner and outer surface notches. The response from the inner and outer surface notches should be as nearly equal as possible. Use the lesser of the two responses to establish the rejection level. On large diameter or heavy wall pipe and tubing, if the inner and outer surface notch amplitude cannot be made equal because of material soundpath distance and inside diameter curvature, a separate rejection level may be established for the inner and outer surface notches.

NOTE 7—*Distance-Amplitude Correction*— A method of compensating for the reduction in ultrasonic signal amplitude as a function of material sound-path distance may be employed. Details of the procedures used to establish and apply the distance-amplitude correction (DAC) curve shall be established by the using party or parties.

12.2 *Dynamic Standardization*—Standardize the equipment under dynamic conditions that simulate the production examination. The pipe or tubing to be examined and the search unit assembly shall have a rotating translating motion relative to each other such that a helical scan path will be described on the outer surface of the pipe or tube. Maintain the speed of rotation and translation constant within  $\pm 10\%$ . Axial scanning with circumferential indexing may be used to provide equivalent coverage.

12.3 The pitch of the feed helix shall be small enough to ensure at least 100 % coverage at the examination distance and sensitivity established during ~~e~~ standardization. Coverage shall be based upon the maximum effective size of the search unit, the pulse density for each instrument channel and the helix.

### 13. Procedure

13.1 Examine the pipe or tubing with the ultrasound transmitted in both circumferential directions for longitudinal discontinuities and, when specified, in both axial directions for transverse discontinuities, under identical conditions used for equipment standardization (see Note 8).

NOTE 8—Identical conditions include all instrument settings, mechanical motions, search unit position and alignment relative to the pipe or tube, liquid couplant, and any other factors that affect the performance of the examination.

NOTE 9—If a requirement exists for both longitudinal and transverse notches the following three options are available:

- (a) Each pipe or tube is passed through a single-channel examination station four times, twice in each direction,
- (b) Each pipe or tube is passed through a two-channel examination station twice, once in each direction, or
- (c) Each pipe or tube is passed through a four-channel examination station once.

13.2 *Standardization Checks*—Periodically check the dynamic standardization of the equipment by passing the reference standard through the examination system in accordance with 12.2. Make these checks prior to any examination run, prior to equipment shutdown after an examination run, and at least every four hours during continuous equipment operation. Restandardize the equipment in accordance with ~~Section 12~~ 12.1 and 12.2 any time the equipment fails to produce the signal amplitudes or other conditions for rejection within the tolerances agreed upon with the contracting agency. In the event that the equipment does not meet this requirement, reexamine all pipe or tubing examined since the last acceptable standardization after restandardization has been accomplished.

13.2.1 When required by the purchaser, more specific restandardization criteria may be specified.

13.3 For many tubular sizes and examination arrangements, there will be a reflection from the entry surface of the pipe or tube. This signal may be observed, but not gated, as a supplement to the required checking of the reference standard to provide increased assurance that the equipment is functioning properly. If such a signal does not exist, make more frequent equipment standardization checks.

13.4 Do not make any equipment adjustments, during examination, unless the complete standardization procedure described in Section 12 is performed after any such adjustment.

13.5 The examination shall be applied to 100 % of the pipe or tubing unless otherwise specified.

NOTE 10—Some traversing mechanisms do not allow examination of pipe or tube ends. When this condition exists, clearly indicate the extent of this effect, per tube, in the examination report.

### 14. Interpretation of Results

14.1 All indications that are equal to or greater than the rejection level established during standardization as described in Section 12, using the agreed upon reference indicators described in 11.5, shall be considered as representing defects and may be cause for rejection of the pipe or tube. Alternatively, the using party or parties may specify specific acceptance criteria.

14.2 If, upon further examination of the pipe or tube, no rejectable indications are detected, the material shall be considered as having passed the ultrasonic examination, except as noted in 13.2.

NOTE 11—Rejected pipe or tubes may be reworked in a manner acceptable to the purchaser. If, upon ultrasonic reexamination of the reworked pipe or tube, no rejectable indications are detected, the material should be considered as having passed the ultrasonic examination.

NOTE 12—Care should be exercised to ensure that reworking a pipe or tube does not change its acceptability with respect to other requirements of the material specification such as wall thickness, ovality, surface finish, length, and the like.

### 15. Documentation

15.1 When a report is required, it shall contain such information as is mutually considered adequate to document that the examination of the pipe or tubes supplied meets the requirements of this practice, and any modifications specified in the contractual agreement.

15.2 When a “third party” examination is required, as might be performed by an independent examination facility, and to the extent specified in the contractual agreement, a permanent record containing objective evidence of the examination results shall be obtained for pipe or tube examined. This may be in the form of a strip chart recording or computerized data of the ultrasonic instrument output during the examination. It shall contain recordings of all standardizations and standardization checks and should be annotated to provide a positive correlation between examination record for each reject pipe or tube and the corresponding pipe or tube. The supplier shall maintain a report of the examination on file. When requested by the customer, a report of the examination shall be submitted to the customer. The report shall include at least the following information:

- 15.2.1 Identification of the material by type, size, lot, heat treatment, and any other pertinent information.
- 15.2.2 Identification of the examination equipment and accessories.
- 15.2.3 Details of the examination technique, including examination speed, examination frequency, and end effects if any.
- 15.2.4 Description of the reference standard, including the actual (measured) dimensions of the artificial reference reflectors.
- 15.2.5 Description of the distance-amplitude correction procedure, if used.
- 15.2.6 Examination results.

## 16. Keywords

16.1 angle beam; nondestructive examination; pipe; tubing; ultrasonic examination

## ANNEXES

### (Mandatory Information)

#### A1. EXAMINATION OF PIPE AND TUBING FOR SPECIAL AND SAFETY APPLICATIONS

A1.1 Introduction— When the end use of pipe or tubing depends critically upon freedom from discontinuities over a certain maximum size, certain additional ultrasonic examination procedures are required to assure that the required quality standards are met. The immersion method is almost always required for examining tubes for these uses. In some instances, such as field examination or where part contact with water is undesirable, the contact method, or non-contact technique, for instance as described in Guide E 1774, may be employed.

A1.1.1 This practice is intended for use with tubular products of any diameter and wall thickness, provided that proper procedures, as described herein, are followed. These procedures are intended to ensure that proper refraction angles and beam shapes are used to provide full volume coverage of pipes and tubes, including those with low ratios of outside diameter-to-wall thickness, and to avoid spurious signal responses when examining small-diameter, thin-wall tubes.

A1.2 Summary of Practice—Pulsed ultrasonic angle beams by either the surface contact or immersion method shall be used. Fig. A1.1 illustrates characteristic angle beam ultrasound entry into the wall of a pipe or tube in the circumferential direction to detect longitudinal defects and in the axial direction to detect transverse defects, when required. The incident and refracted beams in these cases are pictured as being generated by a cylindrically focused immersion search unit. In pipes and tubes with diameters several times larger than the length of a contact search unit, the general beam shapes are approximately the same.

#### A1.3 Additional Apparatus Requirements

A1.3.1 Although contact search units may be used for small quantity and field examinations of pipes and tubes, cylindrically (line) focused immersion search units are preferred for critical examinations and for larger quantities (See References (1), (3) and (4)). Search unit element size and focused beam length shall be suitable for achieving reliable detection of defects equivalent in size to the reference notches at the scanning pitch or index used. When examination of heavy-wall pipes and tubes is required the focal length, refraction angle and included beam angle of focused search units shall be suitable for complete through-wall coverage (See (5)).

A1.3.2 The beam length of the search unit in the wall material must be either longer or shorter than the length of longitudinal notches in the reference standard, by an amount that is no less than the “pitch” (linear advance per revolution) of the helical scan path (see A2.1). This is necessary to ensure detection of discontinuities that are as long as the notches in spite of their random locations with respect to the scan path, (See Annex A2).

A1.3.3 The focal length of a focused immersion search unit should equal the pipe or tube radius plus a convenient water path length so that it may be focused on the pipe or tube centerline (See (4)).

A1.3.4 The angle of the central beam of the search unit, with respect to a perpendicular to the tangent to the surface at the point of beam incidence, shall be adjusted to produce a suitable refraction angle in the pipe or tube wall to provide complete coverage of the pipe or tube wall thickness (See (5)). A refraction angle of 45 degrees is typically used when examining pipe or tubes with a diameter-to-wall thickness ratio of no less than about 10 to 1. For many materials a 45 degree refraction angle may be achieved with a beam incidence angle of about 18 to 19 degrees. This may be achieved in the immersion method by parallel offsetting the beam centerline from a perpendicular to a tangent of the surface by a distance equal to  $\frac{1}{6}$  of the outside diameter of the pipe or

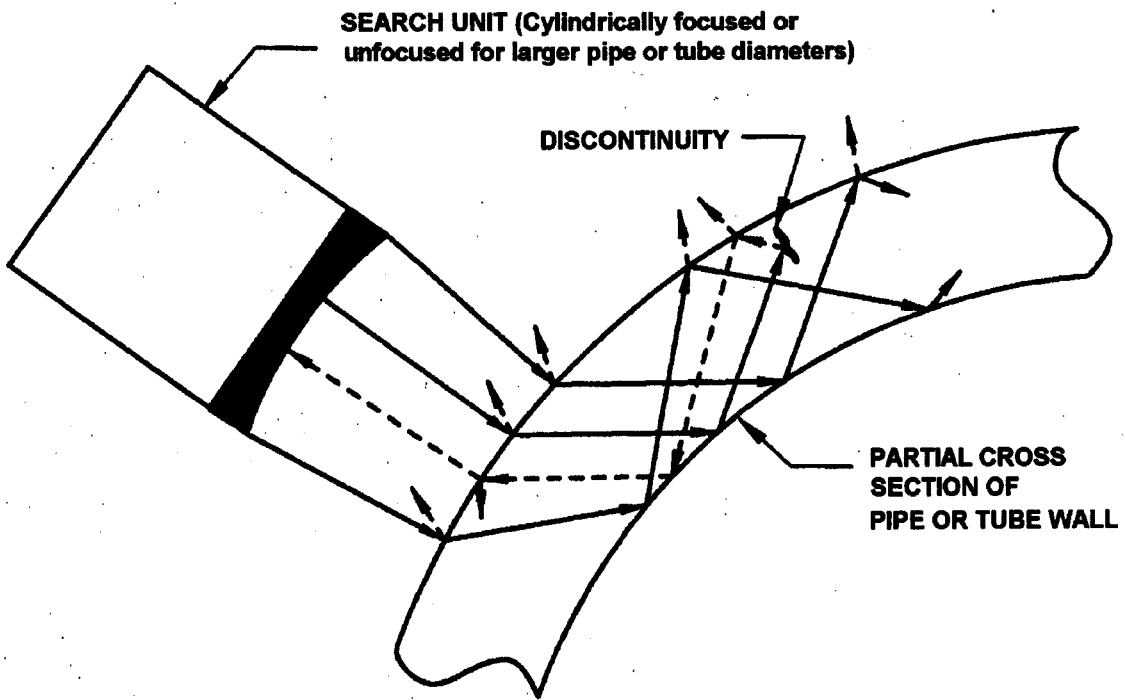

**(a) Circumferential Scan to Search for Axial (Longitudinal) Discontinuities**

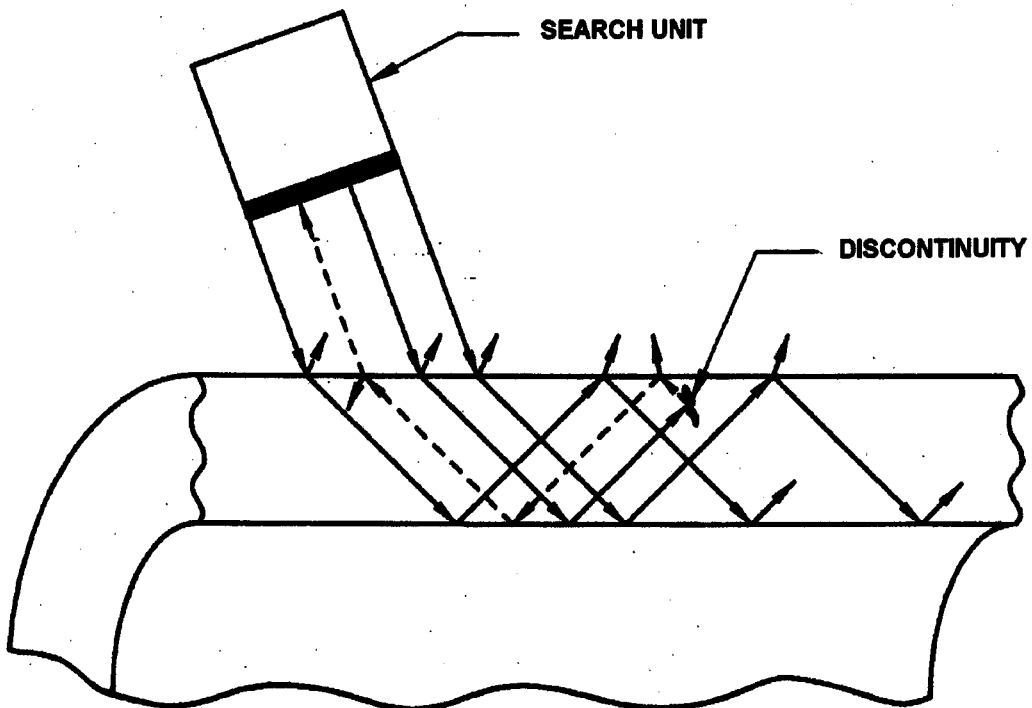

**(b) Axial Scan to Search for Circumferential (Transverse) Discontinuities**

**FIG. A1.1 Beam Propagation in Pipe or Tube Walls**

tube. This is often a convenient initial adjustment during system standardization.

#### **A1.4 Additional Reference Standard Requirements**

A1.4.1 Outer surface and inner surface longitudinal reference notches may be placed near one end of the reference standard separated by a sufficient distance from each other and from the end to preclude interference and interpretation difficulties, but close enough to each other to minimize the time required in scanning from one to other to achieve good signal balance during set-up. For ease of fabrication, the inner surface notch should be nearer the end of the pipe or tube. When required, transverse outer surface and inner surface reference notches are typically placed in the same manner near the opposite end of the reference standard from the longitudinal notches. Although not mandatory, this practice enables all notches to be placed far enough from the ends to insure good support of the material end nearest the search unit(s) during set-up, and the inner surface notches to be near ends to facilitate insertion of the fabrication and verification means. This procedure becomes less critical for material of larger diameters and stiffness.

A1.5 Static Standardization—Using the reference standard specified in Section 11, adjust the equipment to produce clearly identifiable indications from both the inner and outer surface notches. The relative responses from both the inner and outer surface notches should be as nearly equal as possible and practical. Some differences in this procedure are required, as described below, depending upon whether the contact or immersion technique is employed.

A1.5.1 Set the positions of all conveyor and drive mechanisms to support and feed the material to be examined in a stable manner and at the desired scan “pitch”, considering conditions for achieving satisfactory—“worst case interception”—and required scan path overlap. (See Annex A2.)

A1.5.2 *Contact Examination Technique* —For field examination, or in other cases where immersion examination is not practical, the contact technique may be employed. It is important to note however that it is more difficult to obtain repeatable and accurate results with this technique because (See (1)):

(a) It is difficult to maintain uniform sensitivity during scanning due to lack of constant pressure on the search unit and inconsistent couplant coverage;

(b) Unless special—“involute”—(2), or similar, search units are used it is impossible to obtain the primary benefit of focusing which is the uniformity of sensitivity versus thickness which results from the production of constant refraction angles throughout the width of the beam;

(c) With a given search unit wedge it is impossible to vary the incident angle to achieve good balance of the signals from outer surface and inner surface notch targets or to lower the incidence angle to obtain good through-wall coverage on thick-wall pipe or tubes;

(d) Maintenance problems may result from wear of the search unit face plates; and,

(e) When manual scanning is employed it is difficult to insure that total surface coverage or any prescribed amount of scan overlap has been achieved.

A1.5.3 When contact examination is performed, the following selection and standardization procedure shall be used unless an alternate procedure is approved by the contracting agency.

(a) Select a search unit size, frequency and wedge angle and shape to produce an approximately 45 degree beam-center shear wave in the tube or pipe wall. If it is determined that a lower refraction angle would be beneficial, a wedge to produce that angle may be used.

(b) Apply the search unit, with a suitable film of couplant, to the surface of the reference standard in the vicinity of the longitudinal reference notches. Direct the search unit beam in one circumferential direction.

(c) While carefully maintaining uninterrupted coupling and constant pressure on the search unit, move it toward and away from the outer surface longitudinal notch to achieve the maximum signal response from it by a beam reflection from the inner surface which is beyond the interface signal on the display screen of the instrument. Adjust the gain control to set the peak response at this reflection location (node) to 80 % of full screen height (FSH).

(d) Without changing the gain control setting from that determined in Step (c) above, move the search unit to the vicinity of the inner surface longitudinal notch and repeat the scanning procedure until the signal from that notch, at a node adjacent to that used for the outer surface notch signal, is maximum. Record the peak amplitude of the signal from the inner surface notch. If this signal is higher than 80 % FSH, lower the gain to bring it to 80 % FSH and move again to the outer surface notch and record its peak amplitude at the new gain setting. The relative response from the inner and outer surface notches shall be as nearly equal as possible by selection of the pair of adjacent inner surface and outer surface notch signal nodes are observed. Use the lesser of the two responses to establish the rejection level. On large-diameter or heavy-wall pipe and tubing, if the inner and outer surface notch signal amplitudes cannot be equalized because of material sound path distance and inside diameter curvature, a separate rejection level may be established for the inner and outer surface notches, or, in this case, DAC may be used to balance the signal amplitudes from the outer surface and inner surface notches.

(e) Repeat steps (a) through (d) while scanning from the opposite circumferential direction.

(f) Repeat the above steps while scanning in both axial directions if detection of transverse notches and discontinuities is required by the user or contracting agency.

A1.5.4 *Immersion Examination Technique* —This is the preferred technique whenever practical (1). Any of the apparatus types

listed in Note 1 (4.1) may be used for this purpose. The following selection and standardization procedure shall be used unless an alternative is approved by the contracting agency.

A1.5.5 Using the guidelines listed below, select a cylindrically focused (line focused) search unit (3) of appropriate frequency, beam length and focal length for the material to be examined and to the sensitivity level (notch sizes) specified by the user or contracting agency. In cases where the type of examination, material dimensions or other properties make the use of spherically or flat focused search units more appropriate either of these types may be used in place of cylindrically focused units.

(a) The frequency shall be selected to produce a desirable signal-to-“noise” ratio (S/N) from the material to be examined at the specified sensitivity. A S/N value of at least 3 to 1 is usually considered to be a minimum. A higher minimum value is desirable and may be specified by the contracting agency.

(b) The focal length must be equal to the pipe or tube radius plus a convenient waterpath length so that the search unit may be focused on the central axis of the pipe or tube after normalization (4). For very large-diameter material where this requirement is found to be impractical search units of other focal lengths or unfocused units may be used.

(c) The beam width, as measured between -3 dB points on a pulse-echo profile as described in Guide E 1065, must be either longer or shorter than the length of the longitudinal notches in the reference standard by the amount of the scan pitch to be employed. This is necessary to ensure consistent “worst case” interception of discontinuities that are as long as the notches in spite of their random location with respect to the scan path. (See Annex A2.)

(d) Position the search unit so that the length of its focused beam is aligned with the long axis of the pipe or tube.

(e) With the water path length adjusted to focus the beam approximately on the outer surface of the pipe or tube, normalize the search unit by adjusting its angulation and offset to peak its response from the surface.

(f) Change the water path so that it is equal to the focal length of the search unit minus the radius of the tube. Readjust the angulation and offset if necessary to renormalize by repeaking the interface signal.

(g) Offset the search unit in a direction that is parallel to its centerline and perpendicular to the longitudinal axis of the tube by the amount required to establish a beam-center incidence angle that will produce the desired refraction angle in one circumferential direction in the tube wall. (For many materials a satisfactory initial offset distance is  $\frac{1}{2}$  of the tube diameter.) For thick-wall tubes a lower refraction angle may be required for examination of the entire thickness (5). Alternatively, the search unit may be angulated in a plane perpendicular to the tube axis to produce the incidence angle.

(h) Move the reference standard to center the outer-surface notch in the search unit beam. Rotate the tube without translation (that is, without motion along its longitudinal axis) and observe on the instrument display screen the motion of the notch signal away from any residual interface signal. The amplitude should decrease and increase as successive reflections of the beam from the inner and outer surfaces intersect the outer surface notch as it moves to various node positions away from the search unit. Select a convenient node well away from the “direct-in” intersection of the beam on the outer surface notch (which coincides with the position of the interface signal). Adjust the gain to set the amplitude of the signal at 80 % FSH and note its horizontal position on the display.

Note— Alternatively, set-up on the inner surface notch may be performed before set-up on the outer surface notch, as described in step (h) above. This inner surface notch signal must be well beyond the direct-in signal from the outer surface notch. The outer surface notch signal subsequently used for standardization should then be from the node immediately beyond the inner surface notch signal to obtain the best condition for attempting to equalize both gated signals in the following step (i).

(i) Move the reference standard to center the inner surface notch in the beam. Rotate the pipe or tube as for the outer surface notch and note the amplitude of the inner surface notch signal that appears just before the selected outer surface notch signal.

(j) Make small adjustments to the offset (or angulation) and to the water path length while alternately observing and attempting to equalize the outer surface and preceding inner surface notch signal amplitudes. Set the higher of the two signals to 80 % FSH and use the lesser of the two signals to establish the rejection level. Set the position and duration of the instrument alarm gate to include both of these signals. For examinations that require stopping and evaluating or marking all relevant indications, or both, set the alarm activation threshold at 40 % FSH. Record all search unit position settings, instrument control settings and standardization signal levels on an examination record sheet.

(k) Repeat the above steps while scanning in the opposite circumferential direction.

(l) When axial scanning for transverse indications is required, repeat the above steps with the search unit angled in first one, then the other axial direction and using translation rather than rotation of the reference standard to select response nodes from outer surface and inner surface notches.

A1.6 Dynamic Standardization—Standardize the equipment under dynamic conditions that simulate the production examination. The pipe or tubing to be examined and the search unit assembly shall have a rotating translating motion relative to each other such that a helical scan path will be described on the outer surface of the pipe or tube. Maintain the speed of rotation and translation constant within  $\pm 10\%$ . Axial scanning with circumferential indexing may be used, especially on larger material, to provide equivalent coverage. A method for achieving the required conditions is described below.

A1.6.1 The pitch of feed helix shall be small enough to ensure 100 % coverage at the examination distance and sensitivity established during static standardization per A1.5. Annex A2 describes how maximum allowable pitch for stable detection may be determined from the length of the longitudinal reference notches and the minimum beam length of the search units.

A1.6.2 A preferred method for dynamic scanning, applicable to all diameters but especially for smaller diameter material, for

example, less than 4 inches (~~100 mm~~) [100 mm] in diameter, is for the examination system to produce a rotating and translating relative motion between the pipe or tubing being examined and the search unit(s). Run the reference standard with random initial translational and angular orientation through the examination station at full speed and scan pitch and observe, during multiple runs of the standard, the stability of the gated alarm signals from all notches in the reference standard on a strip-chart recorder or other means for observing signal amplitude stability or alarm function. In the absence of an alternate procedure approved by the contracting agency, the peak signal amplitudes must remain constant within 10 % FSH for the number of successive runs specified in an approved examination procedure (a minimum of six is suggested) or, if another defect alarm device is used, it shall provide consistent operation for the specified number of runs. If indexed axial scanning is used, the same stability verification procedure and criteria shall apply.

### **A1.7 Additional Mandatory Procedure Requirements**

**A1.7.1 Standardization Checks**—Periodically check the standardization of the equipment by passing the reference standard through the examination system. Make these checks prior to any examination run, prior to equipment shutdown after an examination run, and at least every hour during continuous equipment operation. Restandardize and reexamine the material if necessary, in accordance with the following procedures, unless otherwise specified by the contracting agency.

**A1.7.2 Restandardization**—If any notch in the reference standard fails to actuate an alarm, or, where defect analysis is made from a strip chart recording of signal amplitudes, if the deviation from the recorded amplitude of the initial standardization signal exceeds 10 % of that amplitude, portions of the static and dynamic standardization procedures of A1.6 shall be repeated until satisfactory operation is obtained. Then the following steps shall be taken, depending upon the nature of the failure.

**A1.7.3 Failure of Alarm Actuation** —When alarm actuation is the only defect indication used, if a notch in the reference standard fails to actuate the flaw alarm during a standardization check, all lengths of material run since the last satisfactory standardization check shall be reexamined after the system has been successfully restandardized.

**A1.7.4 Decrease of Recorded Notch Signal Amplitude of Between 10 and 20 % and No Recorded Indications** —In the case of a recorded examination wherein the signal amplitude from any notch in the rerun reference standard has decreased from the average value of the initially recorded amplitudes by more than 10 % but less than 20 %, no rerun of parts is required after restandardizing if, since the last satisfactory standardization check, there were no recorded unrejected signal indications that were greater than 50 % of the average amplitude of the initially recorded signals. However, restandardization shall be performed to bring the signal amplitude to within 10 % of the average of the initially recorded values before examination is resumed.

**A1.7.5 Decrease of Recorded Notch Signal Amplitude of Over 20 % or of Between 10 and 20 % With Indications**

If the rerun recorded value is less than the average of the initial recorded amplitudes by more than 20 %, or if the decrease is between 10 % and 20 % and there are unrejected indications of greater than 50 % of the average initial standardization amplitude, the entire lot of material examined since the last satisfactory standardization check shall be reexamined after restandardization.

**A1.7.6 Increase of Recorded Notch Signal Amplitude**

If any recorded notch signal amplitude is found to have increased by more than 10 % above the average of the initially recorded values, restandardization shall be performed to bring the signal level to within that range. If the increase is between 10 % and 20 % no rerun of material is required. If the increase is greater than 20 %, and there have been indications rejected since the last satisfactory standardization check, the entire lot of material run since the last standardization check shall be reexamined.

**(Mandatory Information)**

## **A2. RESTRICTION ON THE SELECTION OF SCAN PITCH**

**A2.1 Determination of Scan Pitch** —The helical scan pitch, however generated, must not exceed the absolute difference between the length of the longitudinal reference notches and the effective length of the search unit beam. This requirement may be stated as:

$$P \leq |N - B|$$

where:

$N$  = Notch Length

$B$  = Beam Length

**A2.1.1** This restriction arises from consideration of the “worst case interception” of the longitudinal notch (and therefore defects of that length) by the search unit beam, regardless of the random initial location of the notch with respect to the scan pattern. The actual length of the worst case interception may be represented by:

$$I_{wc} = \{N + B - P\} / 2$$

**A2.1.2** The length of the “best case” random interception of the notch by the beam is equal either to “N” or “B”, depending on which is longer. The fractional percentage change in notch interception length, and therefore signal amplitude, between worst and best interceptions may be obtained by dividing  $I_{wc}$  by either “N” (if “B” is longer) or by “B” (if “N” is longer); that is:

$$I_{wc} / N = 1 / 2 + \{B - P\} / 2N$$

or

$$I_{wc} / B = 1 / 2 + (N - P) / 2B$$

A2.1.3 It is seen from these equations that if the pitch is equal to either the beam length (if it is greater than N) or to the notch length (if it is greater than B), the percentage change between best and worst case random interceptions of the notch by the beam will be 0.5 or 6 dB. No acceptable standardization repeatability can be provided in that case. However, if  $P = N - B$  is substituted in the first of the above equations, or  $P = B - N$  is substituted in the second, the ratio of worst to best case interception is 1.0. This indicates no signal variation due to random alignment and is the prescribed condition for maximum pitch if “invariant” notch detection is to be assured.

## REFERENCES

- (1) Bar-Cohen, Y., “Introduction to Ultrasonic Testing,” *Nondestructive Testing Handbook*, 2nd Ed., Vol. 7, pp 220,221, 1991, Am. Soc. for Nondestructive Testing, Columbus, Ohio.
- (2) Toth, J.M., and B.J. Ross, “The Involute Search Unit-A New Concept in the Ultrasonic Inspection of Pipe,” *Materials Evaluation*, Vol. 39, No. 9, Aug. 1981, pp 828-833.
- (3) Ensminger, D., *Ultrasonics - Fundamentals, Technology, Applications*, 2nd Ed., p 296, 1988, Marcel Dekker, Inc. N.Y. and Basel.
- (4) Beck, K.H., “Ultrasonic Transducer Focusing for Inspection of Cylindrical Material,” *Materials Evaluation*, Vol.49, No. 7, July 1991, pp 876 - 882, ASNT.
- (5) Beck, K.H., “Ultrasonic Refraction Angles for Inspection Throughout the Total Wall Thickness of Tubes and Pipes,” *Materials Evaluation*, Vol.51, No. 5, May 1993, pp 607-612, ASNT.

*ASTM International takes no position respecting the validity of any patent rights asserted in connection with any item mentioned in this standard. Users of this standard are expressly advised that determination of the validity of any such patent rights, and the risk of infringement of such rights, are entirely their own responsibility.*

*This standard is subject to revision at any time by the responsible technical committee and must be reviewed every five years and if not revised, either reapproved or withdrawn. Your comments are invited either for revision of this standard or for additional standards and should be addressed to ASTM International Headquarters. Your comments will receive careful consideration at a meeting of the responsible technical committee, which you may attend. If you feel that your comments have not received a fair hearing you should make your views known to the ASTM Committee on Standards, at the address shown below.*

*This standard is copyrighted by ASTM International, 100 Barr Harbor Drive, PO Box C700, West Conshohocken, PA 19428-2959, United States. Individual reprints (single or multiple copies) of this standard may be obtained by contacting ASTM at the above address or at 610-832-9585 (phone), 610-832-9555 (fax), or service@astm.org (e-mail); or through the ASTM website (www.astm.org).*