



Standard Test Method for Determining the L/D Ratio of Neutron Radiography Beams¹

This standard is issued under the fixed designation E 803; the number immediately following the designation indicates the year of original adoption or, in the case of revision, the year of last revision. A number in parentheses indicates the year of last approval. A superscript epsilon (ϵ) indicates an editorial change since the last revision or reapproval.

1. Scope

1.1 This test method defines an empirical technique for the measurement of the effective collimation ratio, L/D , of neutron radiography beams. The technique is based upon analysis of a neutron radiographic image and is independent of measurements and calculations based on physical dimensions of the collimator system. The values derived by this technique should be more accurate than those based on physical measurements, particularly for poorly defined apertures.

2. Referenced Documents

2.1 ASTM Standards:

E 748 Practices for Thermal Neutron Radiography of Materials²

E 1316 Terminology for Nondestructive Examinations²

3. Summary of Test Method

3.1 Determination of neutron beam L/D ratio using the NU (no umbra) technique³ is accomplished by radiographing the NU device with the neutron beam to be measured and subsequently analyzing the radiograph by one of three methods. Each of the three methods is based upon the determination of that point at which the umbral shadow width reaches zero. See Fig. 1. A key feature of the NU technique is that L/D can be determined accurately without the need for expensive instrumentation. Neutron radiography practices are discussed in Practices E 748 and the terms are defined in Terminology E 1316.

4. Significance and Use

4.1 The quality of a neutron radiographic image is dependent upon many factors. The L/D ratio is one of those factors

and constitutes a numerical definition of the geometry of the neutron beam. The L/D ratio required for a specific neutron radiographic examination is dependent upon the thickness of the specimen and the physical characteristics of the particular element of interest. Use of this test method allows the radiographer and the user to determine and periodically check the effective collimation ratio.

5. Apparatus

5.1 *NU Device* (see Figs. 2(a), 2(b), and 3) employs neutron absorbing rods positioned at various distances from the image plane. In practice this device consists of cadmium and nylon rods located in V-grooves accurately machined in the surface of an aluminum channel section set at a $45 \pm 1/4^\circ$ angle to the side support plate. Near the image plane end the V-grooves are machined on 0.283-cm centers. After 21 V grooves, counting one on the end, the grooves are machined on 0.707-cm centers to the source end. The 0.64-mm diameter cadmium and nylon rods are laid into the V-grooves and secured with neutron transparent adhesive tape. The aluminum channel is supported by side plates to maintain the $45 \pm 1/4^\circ$ angle relative to the image plane. While cadmium rods with diameters other than 0.64 mm may be used, the exact rod diameter must be known and the depth of the V grooves must be adjusted accordingly.

5.2 A single A unit as shown in Fig. 2(b) is used for L/D values expected to be less than 150. Alternately, a single A unit used with appropriate spacers may be used to accommodate a wide range of L/D values.

6. Procedure

6.1 Place the NU device against the cassette with the finely spaced rods nearest the cassette.

6.2 Align the plane of the cassette perpendicular to the axis of the neutron beam.

6.3 Expose the single-emulsion film and NU device for a time span that will produce a nominal background film density of 2.5 ± 0.4 .

6.4 Process the exposed film in accordance with the manufacturer's recommendations.

6.5 Analyze the resultant image in accordance with one or more of the three methods outlined in Section 7.

¹ This test method is under the jurisdiction of Committee E07 on Nondestructive Testing and is the direct responsibility of Subcommittee E07.05 on Radiology (Neutron) Method.

Current edition approved May 15, 1991. Published July 1991. Originally published as E 803 – 86. Last previous edition E 803 – 86.

² *Annual Book of ASTM Standards*, Vol 03.03.

³ Newacheck, R. L., and Underhill, P. E., "The NU Method for Determining L/D Ratio Of Neutron Radiography Facilities," Aerotest Operations, Inc., Report A.O. 77-27, June 1977.

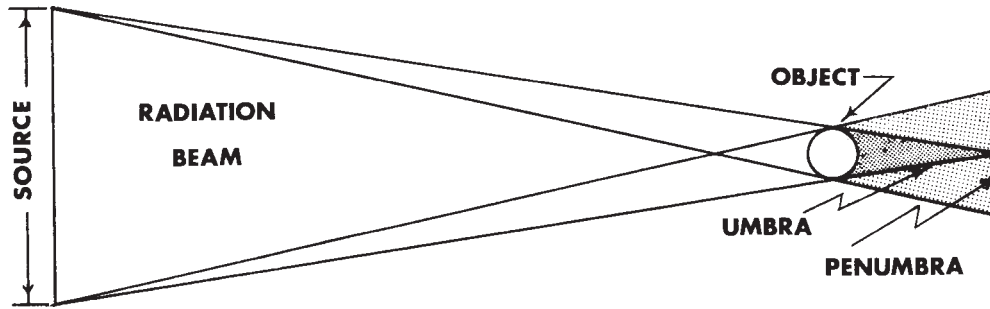
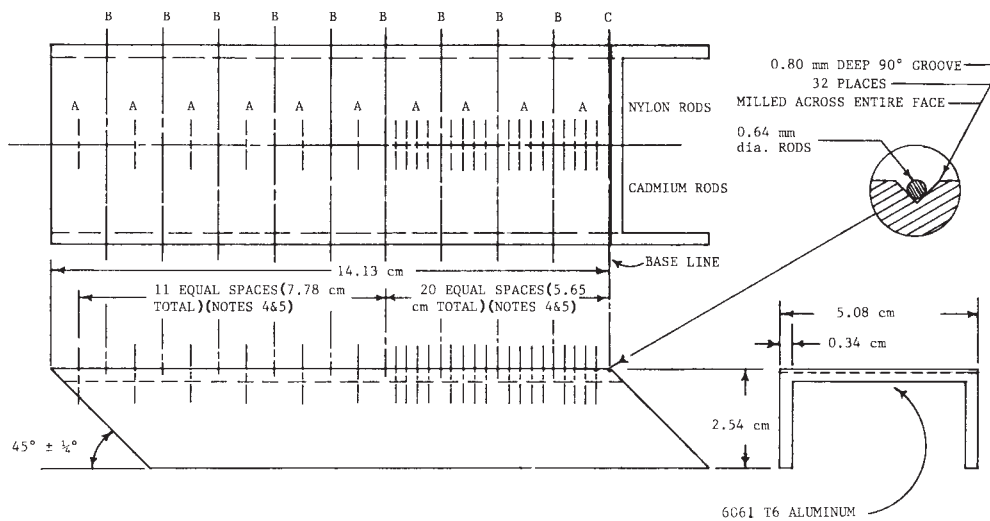

FIG. 1 Diagram of Zero Umbra Image Configuration



NOTE 1—Rods at “A” positions are 1 cm each side of center line (22 ea.)

NOTE 2—Rods at “B” positions are 2 cm each side of center line (9 ea.)

NOTE 3—Rods at “C” positions are 2.5 cm each side of center line (1 ea.)

NOTE 4—All dimensions from base line to reduce accumulative errors

NOTE 5—Rod arrangement shown for single system device. For an add-on device, to form a double system, extend the 11 spaces for 7.78 cm to 19 spaces for 13.43 cm and eliminate the close spacing (20 for 5.65 cm)

NOTE 6—Rods held tightly in position with one layer of transparent tape

2(a) Support Channel Subassembly with Rod Spacing

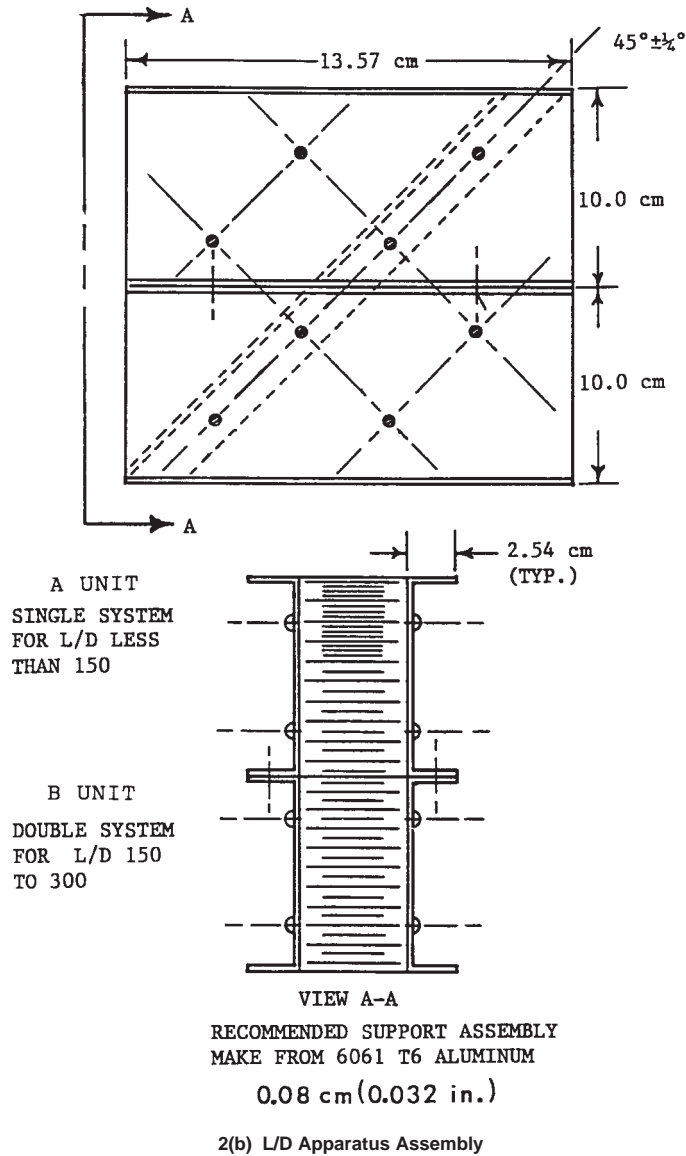

7. Data Analysis

7.1 *Visual Analysis*—A visual determination of the L/D ratio can be made directly from the neutron radiograph. When observing the individual rod images, the umbral image can be recognized as the “white” line along the center of the rod image. This “white” line will decrease in width for the rods located farther and farther from the film. At some point the umbral images will disappear. Beyond this point a less intense white line will appear and increase in width with increasing rod distance. Use of a 5 to 10-power magnifier will aid in determining the point at which the “white” line disappears and then increases in width with a decreased intensity. Based on the visual observation, determine the rod with zero umbral width and then determine its distance (b) from the cassette. The L/D ratio is as follows:

$$L/D = (b/\text{rod diameter})$$

7.2 *Microdensitometric Analysis*—The second data analysis method is based on a microdensitometric scan across the cadmium rod images beginning with the “0” position rod nearest the film. A typical scan is shown in Fig. 4. A densitometer aperture of $20 \times 300 \mu\text{m}$ and no horizontal expansion is suggested for this method. The value of b is obtained from the intersection of a straight line originating from the tip (low film density) of the scan of the “0” rod and a curved line through the tips of the remaining wave forms as shown in Fig. 4. This method gives the best results for L/D ratios up to a few hundred. Higher L/D ratios cannot be determined by this method due to the inability to obtain a stable wave form for large values of b .

7.3 *Alternative Microdensitometric Analysis*—This method also uses scanning microdensitometric traces for L/D ratio determinations and is applicable for both high and low L/D ratios. For this method the recommended microdensitometer

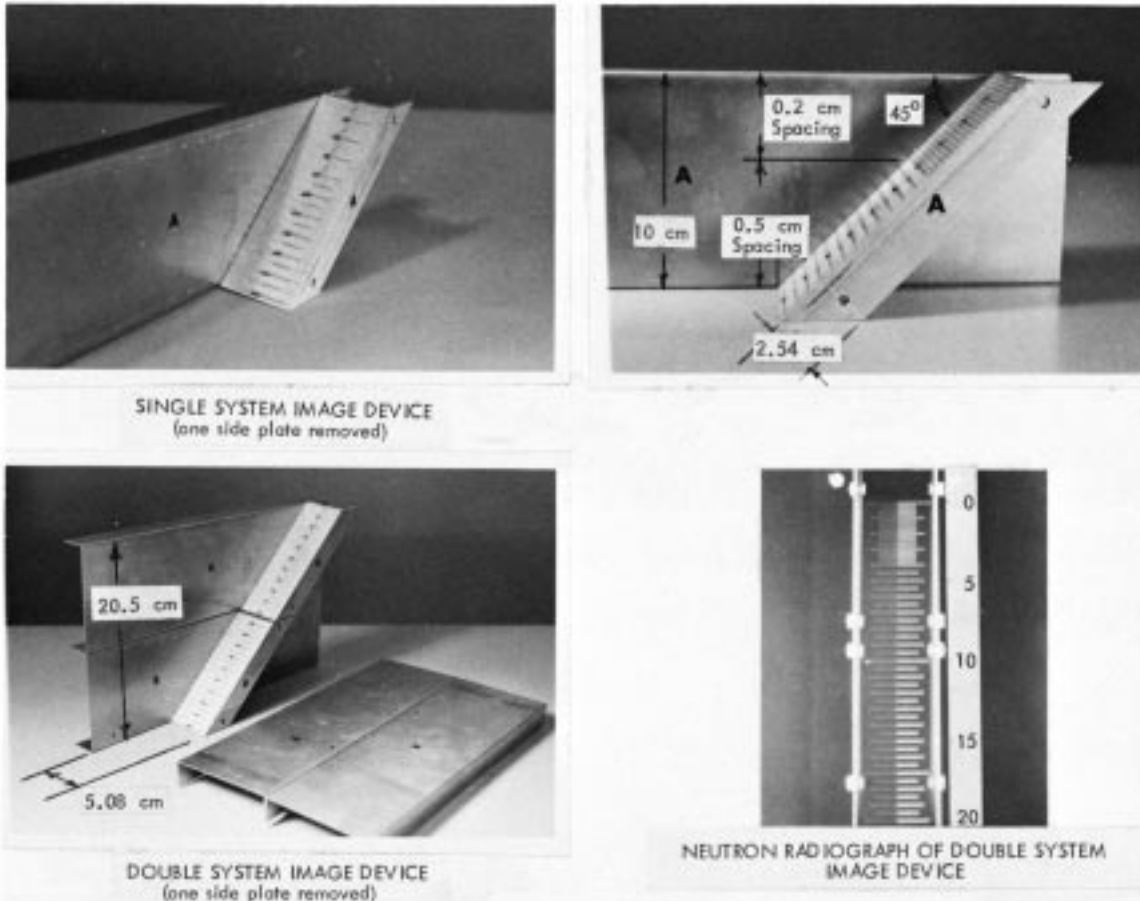

FIG. 3 NU Device Pictorials

settings are: $20 \times 300\text{-}\mu\text{m}$ aperture and $50\times$ (or more) chart recording expansion. These settings will produce individual wave forms as shown in Fig. 5. At least two wave forms must be scanned, one near the film plane and one other near the point where the umbra disappears. Care must be taken not to go beyond the point where the umbral image disappears. Microdensitometer settings must remain the same for all scans. For L/D ratios above 100, the “0” centimetre rod image should not be used because the unsharpness due to the film/conversion screen combination overrides the unsharpness due to the L/D ratio. For the lower L/D ratios (under ~ 100), the simplified equation using X_2 and U_0 for the “0” rod image may be used with good results.

7.3.1 To determine the value of b it is necessary to measure the umbral image width for the two rods selected. This dimension is measured along a horizontal line (parallel to background) through the average of the low-density scan of the individual wave form. The desired dimension is the distance between the intersections of this horizontal line with lines drawn through the two sides of the wave form. The measurement may be centimetres or inches and need not be converted to the unmagnified value.

7.3.2 Using this dimension, determine the value of b as follows (see Fig. 6):

$$b = (U_1 X_1) / (U_1 - U_2) + X_0$$

where:

U_1 = umbral width of a rod near the image plane,

U_2 = umbral image width of a rod near the distance where the umbra disappears,

X_0 = distance from the film to the rod chosen for U_1 , cm, and

X_1 = distance between the two rods chosen for analysis, cm.

Since $L/D = b/\text{rod diameter}$, it is possible to determine L/D directly as follows:

$$L/D = \left[\frac{U_1 X_1}{U_1 - U_2} + X_0 \right] / \text{rod diameter}$$

For low L/D ratios (<100) the following equation may be used:

$$L/D = L/D = \left[\frac{U_0 X_2}{U_0 - U_2} \right] / \text{rod diameter}$$

where:

U_0 = umbral image of a rod adjacent to the cassette window and

X_2 = distance from cassette to rod U_2 .

7.3.3 The highest degree of accuracy can be obtained by measuring the umbral width of several rods. These measurements and their respective distances from the image plane are analyzed by a linear regression technique (or alternatively by a best-fit curve of the plotted data) to determine the x -axis

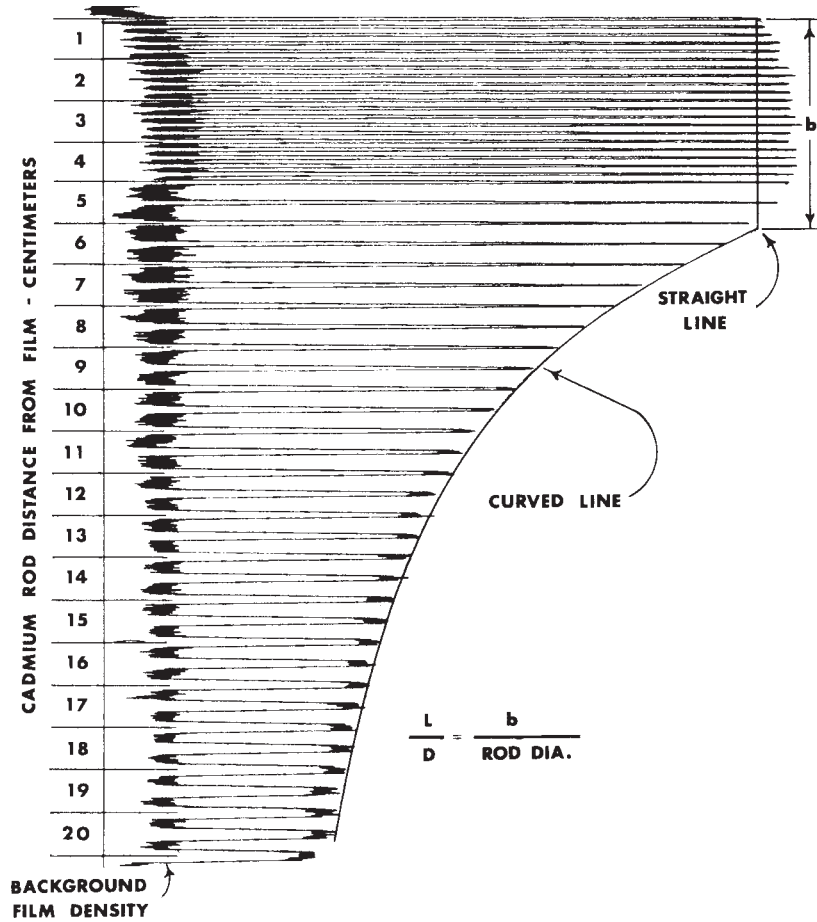

FIG. 4 Microdensitometer Scan 1:1

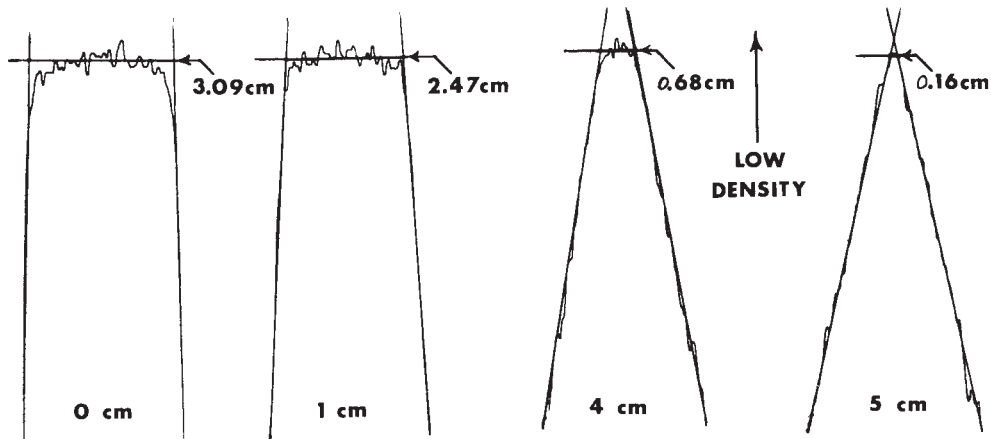

FIG. 5 Film Density Scans of Individual Cadmium Rods 50:1

intercept that is the value of b . L/D ratio is simply $b/\text{rod diameter}$. This technique is recommended for L/D ratios above 200.

8. Keywords

8.1 beam collimation; L/D ratio; neutron radiography; radiographic unsharpness; umbral shadow

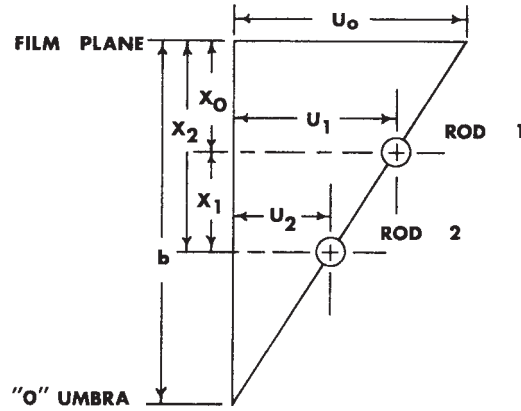

FIG. 6 Diagrammatic Math Model

APPENDIXES

(Nonmandatory Information)

X1. THEORY

X1.1 The collimation ratio of a neutron radiography beam is defined as the distance between the source and the image plane (L) divided by the diameter of the source (D). Since the source diameter (D) is typically large (>2 cm), and because materials with very high neutron attenuation coefficients are available, a unique approach to L/D ratio determination is possible. If an opaque rod with a diameter much smaller than the source diameter is placed near the image plane, an umbral

shadow will be cast as shown in Fig. X1.1.

X1.2 For a given source diameter (D) and a given rod diameter (d), there will be a rod to image plane distance (b) where the width of the umbral shadow on the image plane will equal zero. For this particular distance a simple formula can be developed to determine L/D ratio:

$$\Delta XYZ \text{ is similar to } \Delta STZ$$

Therefore:

$$L/D = b/d$$

where:

- L = source to film distance (Note X1.1),
- D = source size = XY in Fig. X1.1,
- b = object to film distance, and
- d = object size = ST in Fig. X1.1.

NOTE X1.1—When $b \ll L$, $L \cong L - b$. Therefore L may also be considered Source to Object Distance. Thus, if the rod diameter is known, the L/D ratio can be calculated because the value of b can be determined from a neutron radiograph of a system of rods.

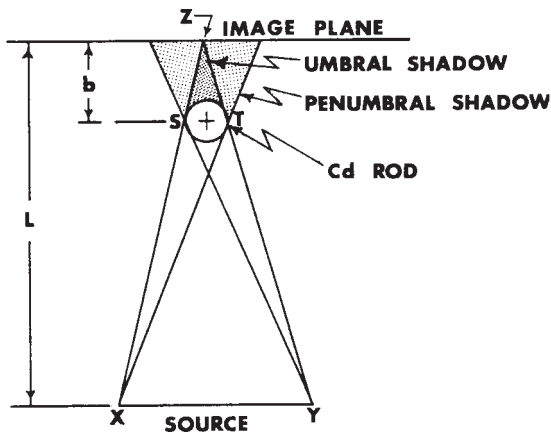

FIG. X1.1 Zero Umbra Geometry

X2. ACCURACY

X2.1 The NU method for determining L/D ratios is particularly accurate in the normal range of L/D ratios used for neutron radiography, that is, 20 to 250. Major sources of inaccuracy are (1) the variations in the cadmium rod diameter; (2) the variations of conversion screen to centerline of first rod distances; (3) the inherent unsharpness of the film/conversion screen system; and (4) the effect of conversion screen gamma

on the film density of the cadmium rods. (4) applies primarily to the method of L/D determination using a 1:1 microdensitometer scan of all rods.

X2.2 Use of the linear regression analysis of individual rod umbral image measurements should provide accuracies of ~ 2 to 3% for L/D ratios up to 1000 assuming the cadmium rod

diameter is accurately known. Any of the analysis techniques utilizing microdensitometer scans should provide an accuracy of $\sim 5\%$ for L/D ratios up to 250 and the visual observation is equally accurate when interpreted by a trained film reader.

X2.3 The visual determination has certain limitations fixed by rod spacing. For example, if the umbral image is observed at 4 cm but is not visible in the 4.5-cm rod image, one can only say that the L/D lies between (4/0.064) and (4.5/0.064) or 62.5 and 70.3. The accuracy is therefore limited to 12.5%. Similarly at an L/D of 20, because the cadmium rods are spaced at 0.2 cm, the best visual accuracy is limited to 16.7% (between 18.75 and 21.87 L/D).

X2.4 The accuracies noted above have been experimentally verified by analysis of neutron radiographic images produced

with facilities having well defined geometrical configurations. The most significant point to be considered in the use of the NU method for determining L/D ratios is that the image is a true indicator. If the values of L/D determined by the NU method disagree with the values determined by geometrical calculations based on alleged source size and source to film distances, it is most probable that the NU method values are more accurate. One should proceed to analyze the source configuration with pinhole techniques to locate source leakage or other problems should the values differ widely. The technique has been found to be equally accurate for circular or square aperture configurations. In the case of a rectangular or oval shaped aperture, the NU device will indicate the L/D ratio normal to the rod direction. Two measurements are necessary to characterize the source.

ASTM International takes no position respecting the validity of any patent rights asserted in connection with any item mentioned in this standard. Users of this standard are expressly advised that determination of the validity of any such patent rights, and the risk of infringement of such rights, are entirely their own responsibility.

This standard is subject to revision at any time by the responsible technical committee and must be reviewed every five years and if not revised, either reapproved or withdrawn. Your comments are invited either for revision of this standard or for additional standards and should be addressed to ASTM International Headquarters. Your comments will receive careful consideration at a meeting of the responsible technical committee, which you may attend. If you feel that your comments have not received a fair hearing you should make your views known to the ASTM Committee on Standards, at the address shown below.

This standard is copyrighted by ASTM International, 100 Barr Harbor Drive, PO Box C700, West Conshohocken, PA 19428-2959, United States. Individual reprints (single or multiple copies) of this standard may be obtained by contacting ASTM at the above address or at 610-832-9585 (phone), 610-832-9555 (fax), or service@astm.org (e-mail); or through the ASTM website (www.astm.org).