



Standard Test Method for Degradation of Fine Aggregate Due to Attrition¹

This standard is issued under the fixed designation C 1137; the number immediately following the designation indicates the year of original adoption or, in the case of revision, the year of last revision. A number in parentheses indicates the year of last reapproval. A superscript epsilon (ϵ) indicates an editorial change since the last revision or reapproval.

1. Scope

1.1 This test method provides a procedure for indicating the degree to which a fine aggregate may be subject to degradation due to the mixing and agitation of portland cement concrete.

1.2 The values given in SI units are to be regarded as the standard. The values given in parentheses are for information only.

1.3 *This standard does not purport to address all of the safety concerns, if any, associated with its use. It is the responsibility of the user of this standard to establish appropriate safety and health practices and determine the applicability of regulatory limitations prior to use.*

2. Referenced Documents

2.1 ASTM Standards:

- C 33 Specification for Concrete Aggregates²
- C 117 Test Method for Materials Finer Than 75- μm (No. 200) Sieve in Mineral Aggregates by Washing²
- C 125 Terminology Relating to Concrete and Concrete Aggregates²
- C 136 Test Method for Sieve Analysis of Fine and Coarse Aggregates²
- C 295 Guide for Petrographic Examination of Aggregates for Concrete²
- C 702 Practice for Reducing Field Samples of Aggregate to Testing Size²
- C 1005 Specification for Reference Masses and Devices for Determining Mass for Use in the Physical Testing of Hydraulic Cements³
- D 75 Practice for Sampling Aggregates⁴
- E 11 Specification for Wire-Cloth Sieves for Testing Purposes⁵

3. Summary of Test Method

3.1 A sample of fine aggregate, of specified grading, is subjected to vigorous agitation under water from the action of a high-speed impeller. Degradation is measured by the de-

crease in fineness modulus (as defined in Definitions C 125) and the increase in amount of materials finer than the 75- μm (No. 200) sieve.

4. Significance and Use

4.1 The tendency of some fine aggregates to degrade from the grinding action in a concrete mixer may affect mixing water demand, entrained air, and slump. Such aggregates may comply with the requirements of Specification C 33. When it is suspected that degradation during mixing is a problem, this test method may be useful in evaluating the extent of the problem.

4.2 This test method may be used for preliminary screening to indicate the need for further evaluation through petrographic examination (Practice C 295) or testing the quality of mortar made from the fine aggregate in question.

4.3 This test method may be of considerable value in comparing the results obtained with unknown materials against those with materials of known performance in concrete.

5. Apparatus

5.1 *Sieves*, conforming to Specification E 11: 75- μm (No. 200), 150- μm (No. 100), 300- μm (No. 50), 600- μm (No. 30), 1.18-mm (No. 16), 2.36-mm (No. 8), 4.75-mm (No. 4), and 9.5-mm ($\frac{3}{8}$ -in.).

5.2 *Balance*—A balance or scale readable and accurate to 0.1 g or 0.1 % of the test load, whichever is greater, at any point within the range of use.

5.3 *Oven*—An oven of appropriate size capable of maintaining a uniform temperature of $110 \pm 5^\circ\text{C}$ ($230 \pm 9^\circ\text{F}$).

5.4 *Attrition Device*—A stainless steel octagonal tank, 140 mm ($5\frac{1}{2}$ in.) high and 110 mm ($4\frac{1}{2}$ in.) minimum inside width, with a motor-driven 19-mm ($\frac{3}{4}$ -in.) vertical shaft so mounted that it can be lowered into the desired position within the octagonal tank. Mounted on the shaft there shall be three horizontal sets of six pitched stainless steel blades⁶ and the shaft and blades shall rotate at approximately 850 r/min when in operation. A lid shall be provided with a hole for the shaft. See Figs. 1 and 2.

5.5 *Rotating Device*—An electric motor-driven device or drill press suitable for driving the impeller clockwise as shown

¹ This test method is under the jurisdiction of ASTM Committee C-9 on Concrete and Concrete Aggregates and is the direct responsibility of Subcommittee C09.20 on Normal Weight Aggregates.

Current edition approved Aug. 10, 1997. Published June 1998. Originally published as C 1137 – 90. Last previous edition C 1137 – 90.

² *Annual Book of ASTM Standards*, Vol 04.02.

³ *Annual Book of ASTM Standards*, Vol 04.01.

⁴ *Annual Book of ASTM Standards*, Vol 04.03.

⁵ *Annual Book of ASTM Standards*, Vol 14.02.

⁶ Available from WEMCO, Minerals Products Division, 1796 Tribute Rd., P.O. Box 15619, Sacramento, CA 95852 (916-929-9363). A $\frac{1}{2}$ -in. attrition tank with 4-in. attriting element (impeller) that can be used in a 850-r/min drill press or in a WEMCO laboratory floatation machine are mentioned in Bulletin No. F7, B2, September 1982, parts No. 23828 (impeller), 23844 (tank), and 44519 (cover).

ASTM C 1137

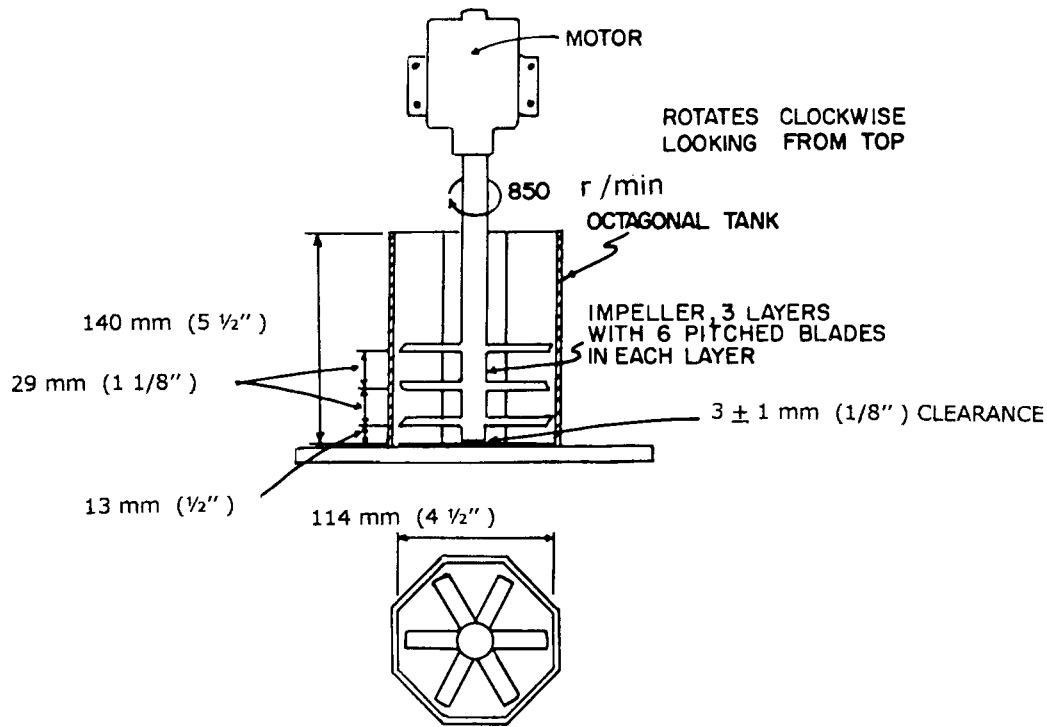
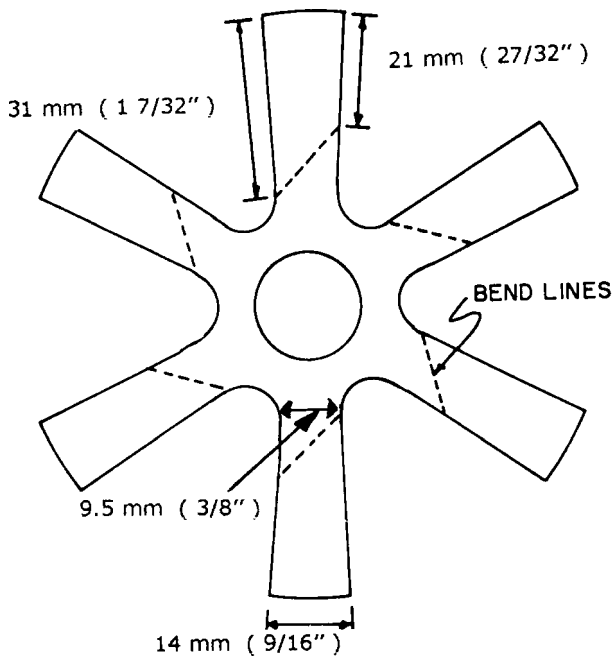

FIG. 1 Attrition Machine



TOP VIEW—TOP IMPELLER
BLADE ENDS BENT LEFT
(COUNTERCLOCKWISE)

Impeller—102 mm (4 in.) diameter × 1.5 mm (No. 16 gage) thick; Three Layers
Shaft—19 mm (3/4 in.) diameter extending 9.5 mm (3/8 in.) below bottom layer and
the ends of the blades bent to 45° pitch. Blades on the top and bottom layer bent
to the left (counterclockwise) and the middle layer bent to the right (clockwise).

FIG. 2 Impeller Details

6. Sample Preparation

6.1 Sample the aggregate in accordance with Practice D 75 and reduce to test portion size in accordance with Practice C 702.

6.2 Prepare at least two test portions of 500 ± 5 g each to have gradings specified in advance. Table 1 lists five alternative gradings that may be specified.

6.3 In preparing test portions to one of the gradings from Table 1, first remove fines as necessary by washing (in accordance with Test Method C 117), then oven dry and sieve (in accordance with Method C 136) into separate size fractions, and reblend.

6.4 If the test is to be performed on one of the standard gradings from Table 1, use the grading nearest that of the as-received sample. Where different fine aggregates are to be compared, use the same initial grading for each.

7. Procedure

7.1 Determine the mass of the test portion of oven-dry fine aggregate to the nearest 0.1 g and record.

TABLE 1 Alternative Test Gradings

Sieve Size	% Passing				
	No. 1	1A ^A	No. 2	No. 2A ^B	No. 3
4.75-mm (No. 4)	100	100	100	100	100
2.36-mm (No. 8)	80	100	88	100	100
1.18-mm (No. 16)	50	60	74	80	85
600- μ m (No. 30)	25	30	49	50	60
300- μ m (No. 50)	10	10	20	20	30
150- μ m (No. 100)	2	0	5	0	10
75- μ m (No. 200)	0	0	0	0	0
Fineness Modulus	3.33	3.00	2.64	2.50	2.15

^A Similar to No. 1 but with the fine and coarser fractions removed.

^B Similar to No. 2 but with the fine and coarser fractions removed.

in Fig. 1. It shall be capable of driving the impeller at approximately 850 r/min with the sample and water in the tank.

7.2 Insert the container and impeller in the drill press and adjust the vertical stop on the feed to position the bottom of the impeller shaft 3 ± 1 mm ($1/8 \pm 1/32$ in.) above the bottom of the container. Make this adjustment prior to each test before introducing the sample. Raise the impeller out of the container. Using a funnel, place the sample in the container. Brush any remaining material from the funnel into the container and add $175 \text{ g} \pm 5 \text{ g}$ of water. Lower the impeller to the previously set test position by turning the feed and chuck by hand simultaneously until the impeller penetrates through the material. Place the lid firmly on the container to avoid loss of the fine aggregate and the water.

7.3 Run the attrition device for $6 \pm 1/10$ min if at 850 r/min or for 5100 ± 85 r.

7.4 Remove the container, lid, and impeller from the drill press and place in a pan. Using a minimum amount of water, wash the sample from the container, impeller, and lid into the pan. Avoid loss of any portion of the sample.

7.5 Allow the samples to settle until the wash is clear, then decant off as much as possible, taking care to avoid loss of any portion of the sample.

7.6 Oven dry the degraded sample to constant mass, and determine and record the mass. If loss from sample is 3 g or less than the original mass, proceed with the following steps. If the loss of mass is more than 3 g the test run is considered invalid.

7.7 Test the sample in accordance with Test Method C 117 and test the remainder in accordance with Method C 136.

7.8 Repeat the test using the duplicate sample.

7.9 Determine the mass of the clean, dry impeller after the test and record its mass to detect any long-term change in the impeller.

8. Report

8.1 Report the following data for both samples:

8.1.1 Grading as-received,

8.1.2 Grading as-tested (from Table 1 or as otherwise specified),

8.1.3 Grading after attrition,

8.1.4 Percent finer than the 75- μm (No. 200) sieve after attrition,

8.1.5 Fineness modulus before and after attrition, and

8.1.6 The mass of the clean, dry impeller after the test.

9. Precision and Bias

9.1 Data on the precision and bias for this test method have not been obtained.

10. Keywords

10.1 agitation; attrition; degradation; fine aggregates; mixing

The American Society for Testing and Materials takes no position respecting the validity of any patent rights asserted in connection with any item mentioned in this standard. Users of this standard are expressly advised that determination of the validity of any such patent rights, and the risk of infringement of such rights, are entirely their own responsibility.

This standard is subject to revision at any time by the responsible technical committee and must be reviewed every five years and if not revised, either reapproved or withdrawn. Your comments are invited either for revision of this standard or for additional standards and should be addressed to ASTM Headquarters. Your comments will receive careful consideration at a meeting of the responsible technical committee, which you may attend. If you feel that your comments have not received a fair hearing you should make your views known to the ASTM Committee on Standards, 100 Barr Harbor Drive, West Conshohocken, PA 19428.

This standard is copyrighted by ASTM, 100 Barr Harbor Drive, West Conshohocken, PA 19428-2959, United States. Individual reprints (single or multiple copies) of this standard may be obtained by contacting ASTM at the above address or at 610-832-9585 (phone), 610-832-9555 (fax), or service@astm.org (e-mail); or through the ASTM website (<http://www.astm.org>).