



Designation: C 143/C 143M – 003

An American National Standard

Standard Test Method for Slump of Hydraulic-Cement Concrete¹

This standard is issued under the fixed designation C 143/C 143M; the number immediately following the designation indicates the year of original adoption or, in the case of revision, the year of last revision. A number in parentheses indicates the year of last reapproval. A superscript epsilon (ε) indicates an editorial change since the last revision or reapproval.

This standard has been approved for use by agencies of the Department of Defense.

1. Scope*

1.1 This test method covers determination of slump of hydraulic-cement concrete, both in the laboratory and in the field.

1.2 The values stated in either inch-pound units or SI units are to be regarded separately as standard. Within the text, the SI units are shown in brackets. The values stated in each system are not exact equivalents; therefore, each system shall be used independently of the other. Combining values from the two systems may result in nonconformance with the standard.

1.3 The text of this standard references notes and footnotes which provide explanatory material. These notes and footnotes (excluding those in tables and figures) shall not be considered as requirements of the standard.

1.4 This standard does not purport to address all of the safety concerns, if any, associated with its use. It is the responsibility of the user of this standard to establish appropriate safety and health practices and determine the applicability of regulatory limitations prior to use.

~~1.4 The text of this standard references notes and footnotes which provide explanatory material. These notes and footnotes (excluding those in tables and figures) shall not be considered as requirements of the standard.~~

2. Referenced Documents

2.1 *ASTM Standards:*

¹ This test method is under the jurisdiction of ASTM Committee C09 on Concrete and Concrete Aggregates and is the direct responsibility of Subcommittee C09.60 on Fresh Concrete Testing.

Current edition approved Aug. 10, 2000³. Published October 2000. ~~September 2003~~. Originally published as D 138 – 22 T; approved in 1922. Last previous edition approved in 2000 as C 143/C 143 – 9800.

*A Summary of Changes section appears at the end of this standard.

C 172 Practice for Sampling Freshly Mixed Concrete²

C 670 Practice for Preparing Precision and Bias Statements for Test Methods for Construction Materials²

3. Summary of Test Method

3.1 A sample of freshly mixed concrete is placed and compacted by rodding in a mold shaped as the frustum of a cone. The mold is raised, and the concrete allowed to subside. The vertical distance between the original and displaced position of the center of the top surface of the concrete is measured and reported as the slump of the concrete.

4. Significance and Use

4.1 This test method is intended to provide the user with a procedure to determine slump of plastic hydraulic-cement concretes.

NOTE 1—This test method was originally developed to provide a technique to monitor the consistency of unhardened concrete. Under laboratory conditions, with strict control of all concrete materials, the slump is generally found to increase proportionally with the water content of a given concrete mixture, and thus to be inversely related to concrete strength. Under field conditions, however, such a strength relationship is not clearly and consistently shown. Care should therefore be taken in relating slump results obtained under field conditions to strength.

4.2 This test method is considered applicable to plastic concrete having coarse aggregate up to 1½ in. [37.5 mm] in size. If the coarse aggregate is larger than 1+2/2½ in. [37.5 mm] in size, the test method is applicable when it is performed on the fraction of concrete passing a 1½-in. [37.5-mm] sieve, with the larger aggregate being removed in accordance with the section titled “Additional Procedure for Large Maximum Size Aggregate Concrete” in Practice C 172.

4.3 This test method is not considered applicable to non-plastic and non-cohesive concrete.

NOTE 2—Concretes having slumps less than ½ in. [15 mm] may not be adequately plastic and concretes having slumps greater than about 9 in. [230 mm] may not be adequately cohesive for this test to have significance. Caution should be exercised in interpreting such results.

5. Apparatus

5.1 *Mold*—The test specimen shall be formed in a mold made of metal not readily attacked by the cement paste. The metal shall not be thinner than 0.060 in. [1.5 mm] and if formed by the spinning process, there shall be no point on the mold at which the thickness is less than 0.045 in. [1.15 mm]. The mold shall be in the form of the lateral surface of the frustum of a cone with the base 8 in. [200 mm] in diameter, the top 4 in. [100 mm] in diameter, and the height 12 in. [300 mm]. Individual diameters and heights shall be within ±1/8 in. [3 mm] of the prescribed dimensions. The base and the top shall be open and parallel to each other and at right angles to the axis of the cone. The mold shall be provided with foot pieces and handles similar to those shown in Fig. 1. The mold shall be constructed without a seam. The interior of the mold shall be relatively smooth and free from projections. The mold shall be free from dents, deformation, or adhered mortar. A mold which clamps to a nonabsorbent base plate is acceptable instead of the one illustrated, provided the clamping arrangement is such that it can be fully released without movement of the mold and the base is large enough to contain all of the slumped concrete in an acceptable test.

5.1.1 Mold with alternative materials.

5.1.1.1 Molds other than metal are allowed if the following requirements are met: The mold shall meet the shape, height, and internal dimensional requirements of 5.1. The mold shall be sufficiently rigid to maintain the specified dimensions and tolerances during use, resistant to impact forces, and shall be nonabsorbent. The mold shall be demonstrated to provide test results comparable to those obtained when using a metal mold meeting the requirements of 5.1. Comparability shall be demonstrated on behalf of the manufacturer by an independent testing laboratory. Test for comparability shall consist of not less than 10 pairs of comparisons performed at each of 3 different slumps ranging from 2-in. [50 mm] to 6 in. [50 to 150 mm]. No individual test results shall vary by more than 0.50 in. [15 mm] from that obtained using the metal mold. The average test results of each slump range obtained using the mold constructed of alternative material shall not vary by more than 0.30 in. [10 mm] from the average of test results obtained using the metal mold. Manufacturer comparability test data shall be available to users and laboratory inspection authorities (see Note 3). If any changes in material or method of manufacture are made, tests for comparability shall be repeated.

NOTE 3—Because the slump of concrete decreases with time and higher temperatures, it will be advantageous for the comparability tests to be performed by alternating the use of metal cones and alternative material cones, to utilize several technicians, and to minimize the time between test procedures.

5.1.1.2 If the condition of any individual mold is suspected of being out of tolerance from the as manufactured condition, a single comparative test shall be performed. If the test results differ by more than 0.50 in. [15 mm] from that obtained using the metal mold, the mold shall be removed from service.

5.2 *Tamping Rod*—A round, straight steel rod 5/8 in. [16 mm] in diameter and approximately 24 in. [600 mm] in length, having the tamping end or both ends rounded to a hemispherical tip, the diameter of which is 5/8 in. [16 mm].

6. Sample

6.1 The sample of concrete from which test specimens are made shall be representative of the entire batch. It shall be obtained in accordance with Practice C 172.

² Annual Book of ASTM Standards, Vol 04.02.

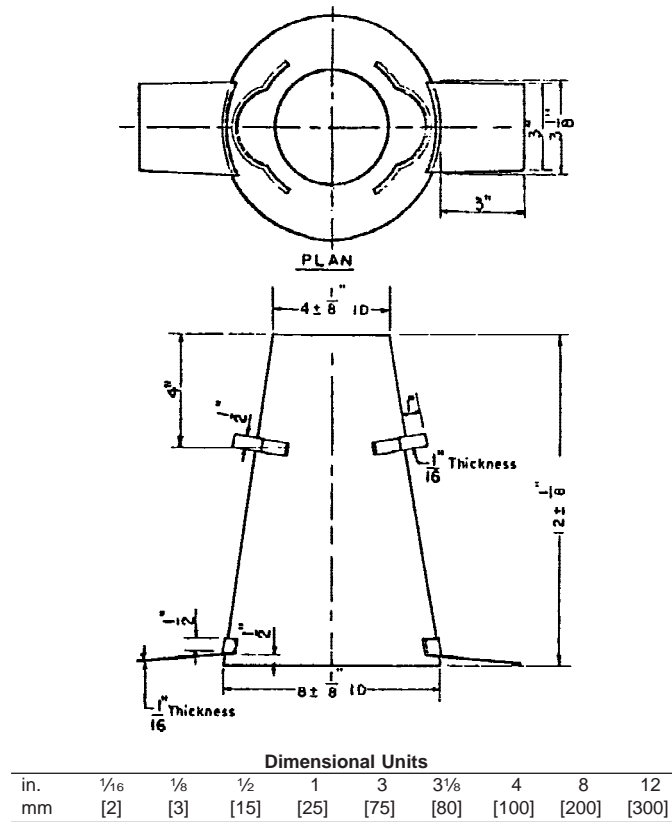

FIG. 1 Mold for Slump Test

7. Procedure

7.1 Dampen the mold and place it on a flat, moist, nonabsorbent (rigid) surface. It shall be held firmly in place during filling by the operator standing on the two foot pieces. From the sample of concrete obtained in accordance with Section 6, immediately fill the mold in three layers, each approximately one third the volume of the mold.

NOTE 4—One third of the volume of the slump mold fills it to a depth of $2\frac{5}{8}$ in. [70 mm]; two thirds of the volume fills it to a depth of $6\frac{1}{8}$ in. [160 mm].

7.2 Rod each layer with 25 strokes of the tamping rod. Uniformly distribute the strokes over the cross section of each layer. For the bottom layer, this will necessitate inclining the rod slightly and making approximately half of the strokes near the perimeter, and then progressing with vertical strokes spirally toward the center. Rod the bottom layer throughout its depth. Rod the second layer and the top layer each throughout its depth, so that the strokes just penetrate into the underlying layer.

7.3 In filling and rodding the top layer, heap the concrete above the mold before rodding is started. If the rodding operation results in subsidence of the concrete below the top edge of the mold, add additional concrete to keep an excess of concrete above the top of the mold at all times. After the top layer has been rodded, strike off the surface of the concrete by means of a screeding and rolling motion of the tamping rod. ~~Continue to hold the mold down firmly and remove concrete from the area surrounding the base of the slump cone mold~~ to preclude interference with the movement of slumping concrete. Remove the mold immediately from the concrete by raising it carefully in a vertical direction. Raise the mold a distance of 12 in. [300 mm] in 5 ± 2 s by a steady upward lift with no lateral or torsional motion. Complete the entire test from the start of the filling through removal of the mold without interruption and complete it within an elapsed time of $2\frac{1}{2}$ min.

7.4 Immediately measure the slump by determining the vertical difference between the top of the mold and the displaced original center of the top surface of the specimen. If a decided falling away or shearing off of concrete from one side or portion of the mass occurs (Note 5), disregard the test and make a new test on another portion of the sample.

NOTE 5—If two consecutive tests on a sample of concrete show a falling away or shearing off of a portion of the concrete from the mass of the specimen, the concrete probably lacks necessary plasticity and cohesiveness for the slump test to be applicable.

8. Report

8.1 Report the slump in terms of inches [millimetres] to the nearest $\frac{1}{4}$ in. [5 mm] of subsidence of the specimen during the test.

9. Precision and Bias³

9.1 *Precision*—The estimates of precision for this test method are based upon results from tests conducted in Fayetteville, Arkansas by 15 technicians from 14 laboratories representing 3 states. All tests at 3 different slump ranges, from 1.0 in. [25 mm] to 6.5 in. [160 mm], were performed using one load of truck-mixed concrete. The concrete was delivered and tested at a low slump, with water then being added and mixed into the remaining concrete to independently produce moderate and finally high-slump concrete. The concrete mixture that used a No. 67 crushed limestone aggregate and a washed river sand, contained 500 lb of cementitious materials per cubic yard [297 kg of cementitious material per cubic metre]. The 500 lb [227 kg] were equally divided between a C150, Type I/II cement and a Class C fly ash. A double dosage of a chemical retarder was used in an attempt to minimize slump losses and maintain workability of the concrete. Concrete temperatures ranged from 86°F [30°C] to 93°F [30 to 34°C]. Slump losses averaged 0.68 in. [17 mm] during the 20 min required to perform a series of 6 tests at 1 slump range. Testing was performed alternately using metal and plastic slump cones, molds, which were determined to produce comparable results. Precision data thus applies to both metal and plastic slump tests were performed.

9.1.1 *Inch-Pound [SI]*—The data used to develop the precision statement were obtained using metric units (millimetres). The precision values shown in inch-pound units are conversions from the millimetre measurements, which were recorded to the nearest 1 mm.

9.1.2 *Measure of Variability*—The standard deviation was determined to be the most consistent measure of variability and was found to vary with the slump value.

9.1.3 *Single-Operator Precision*—The single-operator standard deviation represented by (1s) is shown in Table 1 by average slump values. The reported results for the replicate readings apply to tests conducted by the same operator performing successive tests, one immediately following the other. Acceptable results of two properly conducted tests by the same operator on the same material (Note 6) will not differ from each other by more than the (d2s) value of the last column of Table 1 for the appropriate slump value and single-operator precision.

9.1.4 *Multilaboratory Precision*—The multilaboratory standard deviation represented by (1s) is shown in Table 1 by average slump values. The reported results for the replicate readings apply to tests conducted by different operators from different laboratories performing tests less than 4 min apart. Therefore, acceptable results of two properly conducted slump tests on the same material (Note 6) by two different laboratories will not differ from each other by more than the (d2s) value of the last column of Table 1 for the appropriate slump value and multilaboratory precision.

NOTE 6—“Same materials,” is used to mean freshly mixed concrete from one batch.

9.2 *Bias*—This test method has no bias since slump is defined only in terms of this test method.

10. Keywords

10.1 concrete; cone; consistency; plasticity; slump; workability

³ The test data used to develop this precision statement were based on tests performed in September 1997. A report of test results is on file at ASTM International Headquarters. Request RR: C09-1022.

SUMMARY OF CHANGES

Committee C09 has identified the location of selected changes to this standard since the last issue (C 143/C 143M – 00) that may impact the use of this standard. (Approved July 10, 2003.)

(I) Revised 7.3 to clarify instructions for performing slump test.

TABLE 1 Precision

Slump and Type Index	Standard Deviation (1s) ^A		Acceptable Range of Two Results (d2s) ^A	
	in.	[mm]	in.	[mm]
<i>Single-Operator Precision:</i>				
Slump 1.2 in. [30 mm]	0.23	[6]	0.65	[17]
Slump 3.4 in. [85 mm]	0.38	[9]	1.07	[25]
Slump 6.5 in. [160 mm]	0.40	[10]	1.13	[28]
<i>Multilaboratory Precision:</i>				
Slump 1.2 in. [30 mm]	0.29	[7]	0.82	[20]
Slump 3.4 in. [85 mm]	0.39	[10]	1.10	[28]
Slump 6.5 in. [160 mm]	0.53	[13]	1.50	[37]

^A These numbers represent, respectively, the (1s) and (d2s) limits as described in Practice C 670.

(2) Changed “slump cone” to “mold” in sections 7.3 and 9.1.

ASTM International takes no position respecting the validity of any patent rights asserted in connection with any item mentioned in this standard. Users of this standard are expressly advised that determination of the validity of any such patent rights, and the risk of infringement of such rights, are entirely their own responsibility.

This standard is subject to revision at any time by the responsible technical committee and must be reviewed every five years and if not revised, either reapproved or withdrawn. Your comments are invited either for revision of this standard or for additional standards and should be addressed to ASTM International Headquarters. Your comments will receive careful consideration at a meeting of the responsible technical committee, which you may attend. If you feel that your comments have not received a fair hearing you should make your views known to the ASTM Committee on Standards, at the address shown below.

This standard is copyrighted by ASTM International, 100 Barr Harbor Drive, PO Box C700, West Conshohocken, PA 19428-2959, United States. Individual reprints (single or multiple copies) of this standard may be obtained by contacting ASTM at the above address or at 610-832-9585 (phone), 610-832-9555 (fax), or service@astm.org (e-mail); or through the ASTM website (www.astm.org).