



Standard Test Methods and Practices for Emulsified Asphalts¹

This standard is issued under the fixed designation D 244; the number immediately following the designation indicates the year of original adoption or, in the case of revision, the year of last revision. A number in parentheses indicates the year of last reapproval. A superscript epsilon (ε) indicates an editorial change since the last revision or reapproval.

This standard has been approved for use by agencies of the Department of Defense.

1. Scope

1.1 These test methods and practices, given under the headings titled Composition, Consistency, Stability, and Examination of Residue, cover the examination of asphalt emulsions composed principally of a semisolid or liquid asphaltic base, water, and an emulsifying agent. The test methods cover the following tests:

Test	Sections
Composition:	
Water Content	4-10
Residue and Oil Distillate by Distillation	11-15
Identification of Oil Distillate by Micro-Distillation	16-20
Residue by Evaporation	21-27
Residue by Evaporation	16-22
Particle Charge of Cationic Emulsified Asphalts	28-33
Particle Charge of Cationic Emulsified Asphalts	23-28
Consistency:	
Viscosity (Saybolt Furol)	34-38
Viscosity (Saybolt Furol)	29-33
Stability:	
Demulsibility	39-44
Demulsibility	34-39
Settlement	45-50
Settlement	40-45
Cement Mixing	51-57
Cement Mixing	46-52
Sieve Test	58-63
Sieve Test	53-58
Coating	64-67
Coating	59-62
Miscibility with Water	68-70
Miscibility with Water	63-65
Freezing	71-73
Freezing	66-68
Coating Ability and Water Resistance	74-81
Coating Ability and Water Resistance	69-76
Storage Stability of Asphalt Emulsion	82-88
Storage Stability of Asphalt Emulsion	77-83
Examination of Residue	89-96
Examination of Residue	84-91
Identification Test for Rapid Setting Cationic Emulsified Asphalt	97-104
Identification Test for Rapid Setting Cationic Emulsified Asphalt	92-99
Identification of Cationic Slow Set Emulsions	105-110
Identification of Cationic Slow Set Emulsions	100-105
Field Coating Test on Emulsified Asphalts	111-116
Field Coating Test on Emulsified Asphalts	106-111
Emulsified Asphalt/Job Aggregate Coating Test	117-122
Emulsified Asphalt/Job Aggregate Coating Test	112-117
Weight per Gallon of Emulsified Asphalt	123-129
Weight per Gallon of Emulsified Asphalt	118-124
Residue by Low-Temperature Vacuum Distillation	130-136
Residue by Low-Temperature Vacuum Distillation	126-131

¹ These test methods are under the jurisdiction of ASTM Committee D-4 D04 on Road and Paving Materials and are the direct responsibility of Subcommittee D04.42 on Emulsified Asphalt Tests.

Current edition approved Feb July 10, 1999; 2000. Published June 1999; September 2000. Originally published as D 244 – 26 T. Last previous edition D 244 – 97ε9.

1.2 The values stated in SI units are to be regarded as the standard. The values given in parentheses are for information only.

1.3 *This standard does not purport to address all of the safety concerns, if any, associated with its use. It is the responsibility of the user of this standard to establish appropriate safety and health practices and determine the applicability of regulatory limitations prior to use.*

2. Referenced Documents

2.1 ASTM Standards:

C 150 Specification for Portland Cement²

C 778 Specification for Standard Sand²

D 5 Test Method for Penetration of Bituminous Materials³

D 70 Test Method for Specific Gravity and Density of Semi-Solid Bituminous Materials³

D 86 Test Method for Distillation of Petroleum Products⁴

D 88 Test Method for Saybolt Viscosity⁵

D 113 Test Method for Ductility of Bituminous Materials³

D 128 Test Methods for Analysis of Lubricating Grease⁴

D 139 Test Method for Float Test for Bituminous Materials³

D 140 Practice for Sampling Bituminous Materials³

D 977 Specification for Emulsified Asphalt³

D 2042 Test Method for Solubility of Asphalt Materials in Trichloroethylene³

D 2397 Specification for Cationic Emulsified Asphalt³

D 3289 Test Method for Specific Gravity or Density of Semi-Solid and Solid Bituminous Materials by Nickel Crucible³

E 1 Specification for ASTM Thermometers⁶

E 11 Specification for Wire-Cloth Sieves for Testing Purposes⁷

E 145 Specification for Gravity-Convection and Forced-Ventilation Ovens⁷

3. Sample Conditioning for Testing

3.1 All emulsions with viscosity requirements of 50°C should be heated to $50 \pm 3^\circ\text{C}$ in the original sample container in a 71°C water bath or oven. The container should be vented to relieve pressure. After the sample reaches $50 \pm 3^\circ\text{C}$, stir the sample to achieve homogeneity.

² Annual Book of ASTM Standards, Vol 04.01.

³ Annual Book of ASTM Standards, Vol 04.03.

⁴ Annual Book of ASTM Standards, Vol 04.04.

⁵ Annual Book of ASTM Standards, Vol 05.01.

⁶ Annual Book of ASTM Standards, Vol 14.03.

⁷ Annual Book of ASTM Standards, Vol 14.02.

COMPOSITION

WATER CONTENT

4. Scope

4.1 This test method covers the procedure for determining the water content of an emulsified asphalt by reflux distillation using a water trap.

5. Significance and Use

5.1 This test method measures the amount of water present in the emulsified asphalt, as distinguished from either bitumen or petroleum solvent.

6. Apparatus and Materials

6.1 *Metal Still*—The metal still (Fig. 1(a)) shall be a vertical cylindrical vessel, preferably of copper, having a faced flange at the top to which the head is tightly attached by means of a clamp. The head shall be made of metal, preferably brass or copper, and shall be provided with a tubulation 25.4 mm (1 in.) in inside diameter.

6.2 *Glass Still*—The glass still (Fig. 1(b)) shall be a short-neck, round-bottom flask, made of well-annealed glass, and having an approximate capacity of 500 mL.

6.3 *Heat Source*—The heat source used with the metal still shall be a ring gas burner of 100-mm (4-in.) inside diameter or an electric mantle heater. The heat source for the glass still shall be either an ordinary gas burner or an electric heater.

6.4 *Condenser*—The condenser shall be a water-cooled reflux glass-tube type, having a jacket not less than 400 mm in length,

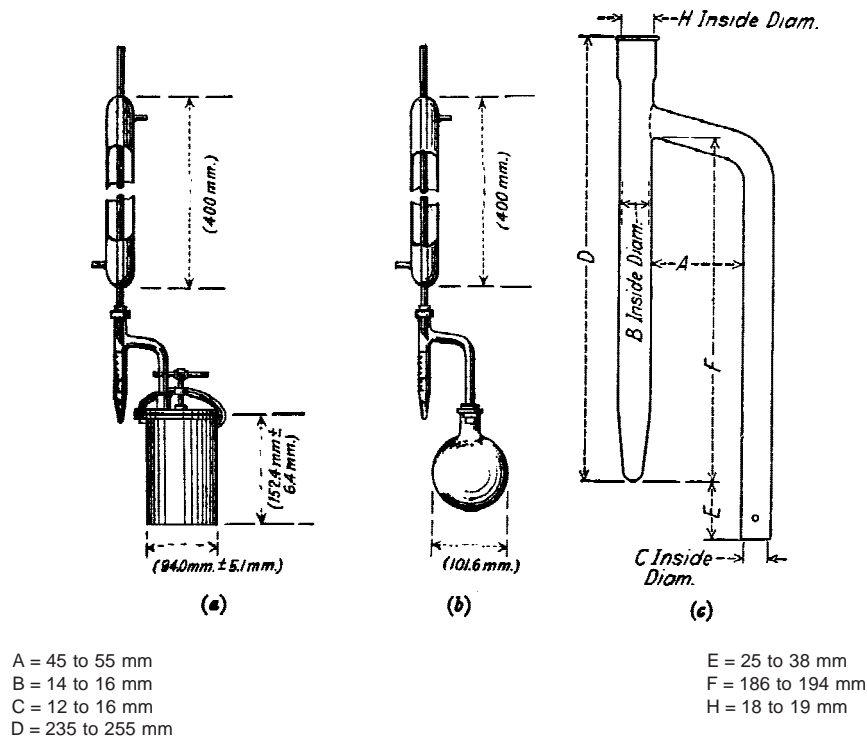

FIG. 1 Apparatus for Determining Water Content

with an inner tube 9.5 to 12.7 mm in outside diameter. The end of the condenser shall be ground to an angle of $30 \pm 5^\circ$ from the vertical axis of the condenser.

6.5 *Trap*—The trap shall be made of annealed glass constructed in accordance with Fig. 1(c) and shall be graduated in 0.10-mL divisions from 0 to 2 mL, and in 0.20-mL divisions from 2 to 25 mL.

6.6 *Solvent*—Xylol or other petroleum distillate conforming to the following distillation requirements: 98 % distills between 120 and 250°C. This distillation shall be conducted in accordance with Test Method D 86.

7. Sample

7.1 Obtain a representative sample of the material for test using standard procedures as specified in Practice D 140.

NOTE 1—The difficulties in obtaining representative samples for this determination are unusually great, so that the importance of sampling cannot be too strongly emphasized.

8. Procedure

8.1 When the material to be tested contains less than 25 % water, place 100 ± 0.1 g of sample in the still. When the material contains more than 25 % water, use a 50 ± 0.1 -g sample. Thoroughly mix the sample to be tested with 200 mL of solvent by swirling, taking proper care to avoid any loss of material.

8.2 Connect the still, trap, and condenser by means of tight-fitting corks as shown in Fig. 1(a) or (b). Adjust the end of the condenser in the trap to a position which will allow the end to be submerged to a depth of not more than 1 mm below the surface of the liquid in the trap after distillation conditions have been established. When using the metal still, insert a heavy paper gasket, moistened with the solvent, between the lid and flange before attaching the clamp.

8.3 When the ring burner is used with the metal still, place it about 76.2 mm above the bottom of the still at the beginning of the distillation, and gradually lower it as the distillation proceeds. Regulate the heat so that the condensate falls from the end of the condenser at a rate of from 2 to 5 drops per second. Continue the distillation at the specified rate until no water is visible on any part of the apparatus and a constant volume of water is obtained in the trap. Remove any persistent ring of condensed water in the condenser tube by increasing the rate of distillation for a few minutes.

9. Calculation and Report

9.1 Calculate the water content as follows:

$$\text{Water content, \%} = (A/B) \times 100 \quad (1)$$

where:

A = volume of water in trap, mL, and

B = original weight of sample, g.

9.2 Report the result as "... water weight percent, ASTM D 244."

10. Precision and Bias

10.1 The following criteria should be used for judging the acceptability of results (95 % probability):

10.1.1 Duplicate results by the same operator should not be considered suspect unless they differ by more than the following amount:

Water Content, weight %
30 to 50

Repeatability, weight %
0.8

10.1.2 The results submitted by each of two laboratories should not be considered suspect unless they differ by more than the following amount:

Water Content, weight %
30 to 50

Reproducibility, weight %
2.0

RESIDUE AND OIL DISTILLATE BY DISTILLATION

11. Scope

11.1 This test method covers the quantitative determination of residue and oil distillate in asphalt emulsions composed principally of a semisolid or liquid asphaltic base, water, and an emulsifying agent.

12. Significance and Use

12.1 This test method can be used for quantitative determination of residue and oil distillates in asphalt emulsions for specification acceptance, service evaluation, control, and research. This test method can also be used to obtain residue and oil distillate for further testing.

13. Apparatus

13.1 *Aluminum-Alloy Still*,⁸ (see Fig. 2), approximately 241.3 mm (9½ in.) in height by 95.3 mm (3¾ in.) in inside diameter with one 121-mm (4¾-in.) inside diameter ring burner,⁹ having holes on the inner periphery and having three spacers, to ensure centering of burner around the still (see Fig. 3).

NOTE 2—Residue by distillation results obtained with iron stills in accordance with Method D 244 – 66 are acceptable. Similarly results obtained with a 127-mm (5-in.) ring burner as in subsequent issues of Test Methods D 244 are acceptable.

13.2 *Connection Apparatus*, consisting of a 12.5 ± 0.5 mm glass or metal connecting tube. The metal connecting tube may be secured to the lid by a threaded compressing fitting. Other condensers of 12.5 ± 0.5 mm glass or metal tubing may be used providing that the wetted length is 400 to 550 mm (15.5 to 21').

13.3 *Graduated Cylinder*, 100-mL, with graduation intervals of 1.0 mL.

13.4 *Thermometer*—Two ASTM Low-Distillation Thermometers, graduated either in Fahrenheit or Celsius degrees as specified, having a range from –2 to +300°C, (30 to 580°F) respectively, and conforming to the requirements for Thermometer 7C or 7F as prescribed in Specification E 1, or any other thermometric device of equal accuracy or response.

NOTE 3—For details of the assembly of apparatus for the distillation test, see Fig. 4.

13.5 *Balance*, capable of weighing 3500 g to within ±0.1 g.

14. Procedure

14.1 Weigh 200 ± 0.1 g of a representative sample of the emulsion in the previously weighed aluminum-alloy still (including lid, clamp, thermometers and gasket, if gasket is used).

14.2 Use a gasket of oiled paper between the still and its cover, or grind the joint to a tight fit. Securely clamp the cover on the still. Other gasket materials may be used providing they withstand the maximum temperature reached during distillation.

14.3 Insert a thermometer, or other thermometric device, through a cork, in each of the small holes provided in the cover. Adjust these thermometers so that the end of the bulb of one is 6.4 mm from the bottom of the still and the bulb of the other is approximately 165.1 mm from the bottom of the still.

14.4 Place the ring burner around the still about 152.4 mm (6 in.) from the bottom of the still. Apply heat by lighting this burner and adjusting to low flame. Also apply just enough heat from a bunsen burner to the connecting tube to prevent condensation of water in this tube.

⁸ Available from P & H Electronics, 442 Columbia St., Lafayette, IN 47901, Koehler Instruments, Inc., 168-56 Douglas Ave., Jamaica, NY 11433, and Humboldt Mfg. Co., 7300 W. Agatite Ave., Chicago, IL 60656.

⁹ Available from Humboldt Manufacturing Co., Catalog No. H-1876, 7302 W. Agatite Ave., Chicago, IL 60656.

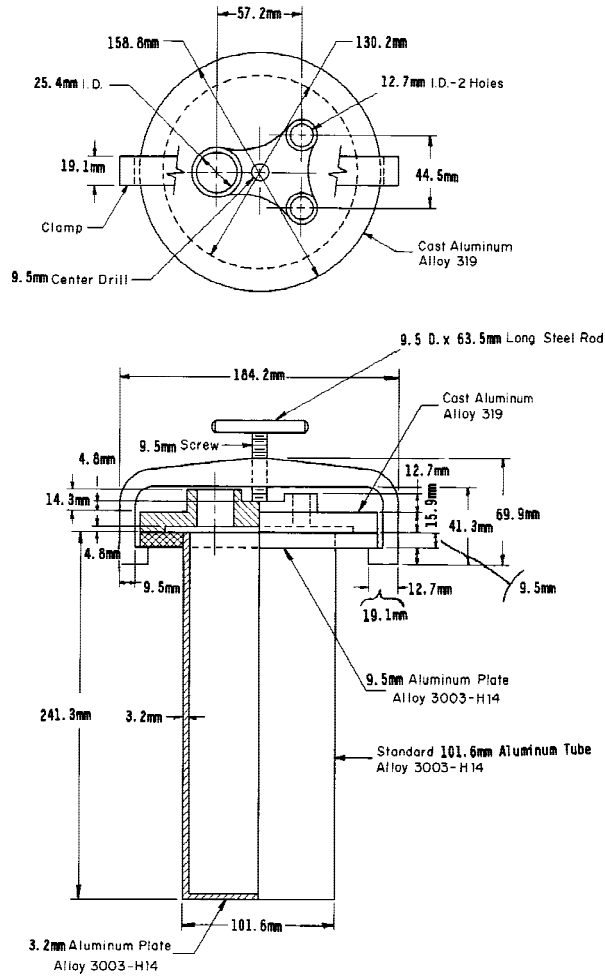

Metric Equivalents

in.	mm
1/8	3.2
3/16	4.8
3/8	9.5
1/2	12.7
9/16	14.3
5/8	15.9
3/4	19.1
1	25.4
1 1/8	41.3
1 1/4	44.5
2 1/4	57.2
2 1/2	63.5
4	101.6
5 1/8	130.2
6 1/4	158.8
7 1/4	184.2
9 1/2	241.3

NOTE 1—The still cover may be machined from Rolled Aluminum Plate Alloy 3003-H14.

FIG. 2 Aluminum-Alloy Still

14.5 Move the ring burner approximately level with the bottom when the temperature can be read on the lower thermometer, approximately 215°C. Increase the temperature to 260 ± 5°C, maintaining it at this temperature for 15 min. Complete the total distillation in 60 ± 15 min from the first application of heat.

NOTE 4—The location of the burner at the start of the test is flexible. It may be raised to decrease chance of foam-over or lowered to middle of still for emulsion containing no solvent. A sudden change in temperature reading of upper thermometer indicates foam on bulb. Remove heat until foaming ceases.

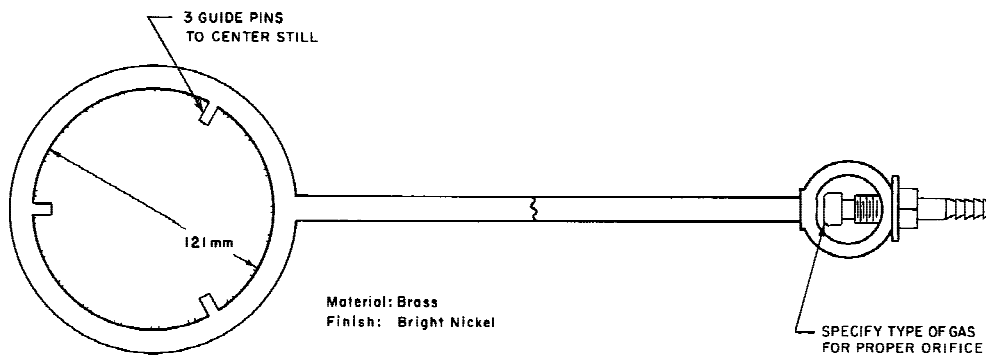
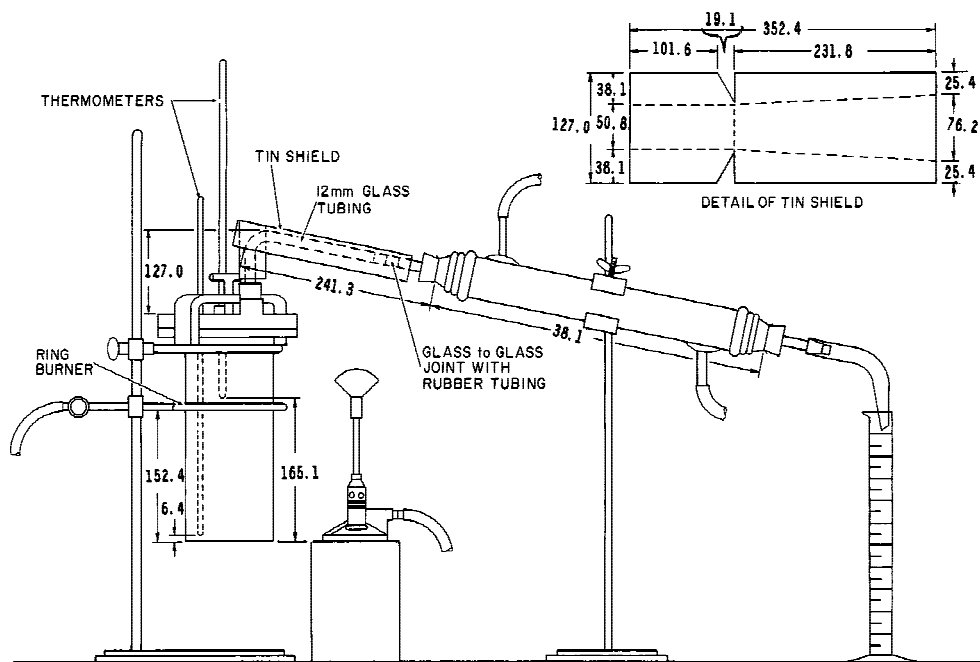

FIG. 3 Ring Burner with 4 3/4-in. (121-mm) Inside Diameter



Metric Equivalents

in.	1/4	3/4	1	1 1/2	2	3	4	5	6	6 1/2	9 1/8	9 1/2	13 7/8	15
mm	6.4	19.1	25.4	38.1	50.8	76.2	101.6	127.0	152.4	165.1	231.8	241.3	352.4	381.0

FIG. 4 Apparatus Assembly for Distillation Test of Emulsified Asphalts

14.6 Immediately at the expiration of the heating period, again weigh the still and accessories as described in 14.1. Calculate and report the percentage residue by distillation. Record the volume of oil distillate to the nearest 1/2 mL. Calculate and report the oil distillate as a volume percentage on the total emulsion. Save this oil distillate if identification is desired.

NOTE 5—The aluminum-alloy still at room temperature (9.1) weighs 1.5 g more than at 260°C. Correct for this error by adding 1.5 g to gross weight obtained in 14.6 prior to calculating the percentage of residue by distillation.

14.7 Remove the cover from the still, stir, and immediately pour suitable portions of the residue into an 8-oz tin or suitable molds and containers for making the required tests. Handle or condition molds and containers for desired examination of the residue as described in Sections 91-96, 86-91, and proceed as required by the appropriate ASTM test method from the points that follow the pouring stage. If there is foreign matter in the residue, the material shall be poured through a 300-µm sieve prior to pouring into the test molds and containers.

15. Precision and Bias

15.1 The following criteria should be used for judging the acceptability of results (95 % probability):

15.1.1 Duplicate results by the same operator should not be considered suspect unless they differ by more than the following amount:

Residue by Distillation,
weight %

Repeatability,
weight %

15.1.2 The results submitted by each of two laboratories should not be considered suspect unless they differ by more than the following amount:

Residue by Distillation,
weight %
50 to 70

Reproducibility,
weight %
2.0

15.2 The precision for penetration of residue from distillation by this method is the same as that shown in Section 84.

IDENTIFICATION OF OIL DISTILLATE 79.

RESIDUE BY MICRO-DISTILLATION-EVAPORATION

16. Scope

16.1 This test method ~~outlines the test procedure~~ covers procedures for redistillation a relatively rapid determination of oil distillate obtained from previously distilled emulsified asphalt sample (Sections 11-15) ~~the percentage of emulsion residue.~~

17. Significance and Use

17.1 ~~The results of this test may be used to indicate compositional characteristics of emulsified asphalt. Evaporation residue may also be subjected to other characterization tests outlined under the oil distillate recovered examination of residue sections. However, properties of the residue from evaporation procedure may differ from those of the emulsified asphalt distillation residue (see Note 7).~~

18. Apparatus

18.1 ~~Apparatus shall be in accordance with Test Method D 86, with the following exceptions:~~

18.1.1 ~~Flask, 10-mL.¹⁰~~

18.1.2 ~~Graduated Cylinder, 10-mL, graduation interval 1/10 mL.~~

18.1.3 ~~Condenser, borosilicate glass, 100-mm jacket.¹¹~~

19. Procedure

19.1 ~~Redistill a 10-mL sample of the oil distillate under prescribed conditions of Test Method D 86, using Group 2 Test Conditions in Table 1 with the following exceptions:~~

—Diameter of hole in flask support, mm	49
—Temperature at start of test:	
—Flask and thermometer	not above ambient
—Graduate and 10-mL charge	not above ambient

20. Calculation and Report

20.1 ~~Calculation and report shall be in accordance with Test Method D 86, where applicable.~~

~~NOTE 6—Better identification of the solvent contained in the emulsion is possible if a larger condenser is used with ice water for the cooling medium during the distillation of the emulsion.~~

RESIDUE BY EVAPORATION

21. Scope

21.1 This test method covers procedures for a relatively rapid determination of the percentage of emulsion residue.

22. Significance and Use

22.1 The test may be used to indicate compositional characteristics of emulsified asphalt. Evaporation residue may also be subjected to other characterization tests outlined under the examination of residue sections. However, properties of the residue from evaporation procedure may differ from those of the distillation residue (see Note 8).

23. Apparatus

~~23.1—~~

~~18.1 Beakers, low form, 1000-mL capacity, made of borosilicate glass or aluminum.~~

~~23.2—~~

⁴⁰ Arthur H. Thomas

¹⁰ Limestone from the Monon Stone Co. Catalog No. 5395 flask of Monon, IN, has been found satisfactory for this purpose, suitable as reference aggregate.

¹¹ Arthur H. Thomas Co. Catalog No. 3906 condenser has been found satisfactory for this purpose.

¹¹ F-95 grade whole grain or equivalent is available from U.S. Silica Sand Co., Ottawa, IL.

18.2 *Glass Rods*, with flame-polished ends, 6.4 mm in diameter and 177.8 mm in length.

~~23.3~~

18.3 *Balance*, capable of weighing 500 g to within ± 0.1 g.

~~23.4~~

18.4 *Oven*, conforming to Specification E 145, Type 1B.

~~23.5~~

18.5 *Sieve*—A 300- μm sieve conforming to Specification E 11.

~~24.~~

19. Procedure A

~~2419.1~~ Use procedure A when determination of the percentage of residue only is required.

~~2419.2~~ Weigh 50 ± 0.1 g of thoroughly mixed, emulsified asphalt into each of three beakers, each beaker having previously been weighed with a glass rod. Place the beakers containing the rods and sample in the oven, the temperature of which has been adjusted to $163 \pm 3.0^\circ\text{C}$, for 2 h. At the end of this period remove each beaker and stir the residue thoroughly. Replace in the oven for 1 h, then remove the beakers from the oven, allow to cool to room temperature, and weigh, with the rods.

~~NOTE 76~~—Care must be taken to prevent loss of asphalt from the beaker through foaming or spattering, or both. Also, the placing of beakers and emulsion samples in a cold or warm oven and bringing the oven and sample up to a temperature of 163°C together is permissible. If preferred, preliminary evaporation of water may be accomplished by careful heating on a hot plate, followed by oven treatment at 163°C for 1 h.

250. Procedure B

~~250.1~~ Use procedure B when tests on the residue from the emulsion are required.

~~250.2~~ Proceed in accordance with 22.2 using four 50 ± 0.1 -g samples. After the calculation for percentage of residue, replace the beakers in the oven until the asphalt residue is sufficiently fluid to pass through a 300- μm sieve (usually requiring 15 to 30 min). Pour the residue through the 300- μm sieve into suitable containers and molds for making such tests as desired, as described in Sections ~~91-95~~ 86-90.

~~NOTE 87~~—As the test method for residue by evaporation described in Sections ~~23-25~~ 18-20 tends to give an asphaltic residue lower in penetration and ductility than the distillation test method described in Sections 13-15, material may be accepted but shall not be rejected as failing to meet specifications containing requirements for determination of residue by distillation, on data obtained by evaporation. If residue from evaporation fails to meet the requirements for properties specified for residue from distillation, tests shall be rerun using the distillation test method.

261. Calculation and Report

~~261.1~~ Calculate the percentage of residue on each beaker as follows:

$$\text{Residue, \%} = 2(A - B) \quad (2)$$

where:

A = weight of beaker, rod, and residue, g, and

B = tare weight of beaker and rod, g.

~~261.2~~ Report the percentage of residue by evaporation as the average of the three results.

272. Precision and Bias

~~272.1~~ The following criteria should be used for judging the acceptability of results (95 % probability):

~~272.1.1~~ Duplicate results by the same operator should not be considered suspect unless they differ by more than the following amount:

Residue by Evaporation, weight %
50 to 70

Repeatability, weight %
0.4

~~272.1.2~~ The results submitted by each of two laboratories should not be considered suspect unless they differ by more than the following amount:

Residue by Evaporation, weight %
50 to 70

Reproducibility, weight %
0.8

PARTICLE CHARGE OF CATIONIC EMULSIFIED ASPHALTS

283. Scope

~~283.1~~ This test method is used to identify cationic emulsions. Positively charged particles are classified as cationic.

294. Significance and Use

~~294.1~~ Cationic emulsions are identified by the migration of the particles to a negatively charged electrode (cathode) by means of a direct current.

30.

25. Apparatus

30.1

25.1 Current Source, of 12-V dc, a milliammeter, and a variable resistor (see Fig. 5 and Fig. 6).

30.2

25.2 Electrodes—Two stainless steel plates, 25.4 mm by 101.6 mm insulated from each other and rigidly held parallel 12.7 mm apart (see Fig. 7).

30.3

25.3 Insulator—Polytetrafluoroethylene resin square rod, virgin electrical grade, 12.7 mm thick (see Fig. 7).

30.4

25.4 Beaker, 250 mL.

30.5

25.5 Glass Rod, 101.6 mm long and 6.35 mm thick or other suitable material or device that is capable of insulating and suspending the electrode assembly in emulsion.

30.6

25.6 Water Bath, capable of maintaining the required testing temperature within the limits specified in this test method.

30.7

25.7 Thermometer, ASTM No. 19C or 19F conforming to the requirements of Specification E 1.

31.

26. Procedure

3126.1 Heat the emulsion to be tested to $50 \pm 3^\circ\text{C}$, in a $71 \pm 3^\circ\text{C}$ water bath. Stir the emulsion thoroughly to ensure uniformity of temperature.

3126.2 Pour the emulsion to be tested into the 250-mL beaker to a height that will allow the electrodes to be suspended 25.4 mm in the emulsion. To facilitate suspension of the electrodes, insert the glass rod or equivalent between the two electrodes under the insulator. Place the ends of the glass rod or equivalent on the two opposite top edges of the beaker. An apparatus capable of manual height adjustment to insulate and suspend electrode assembly in emulsion may be used if desired.

3126.3 Connect the electrodes, that have been properly cleaned (Note 9; 8), to the dc source.

NOTE 9—New electrodes and electrodes to be re-used should be cleaned in the following sequence:

1. Wash with distilled water,
2. Wash with a suitable asphalt solvent,
3. Wash with isopropyl or ethyl alcohol, and
4. Wash with distilled water.

3126.4 Adjust the current to at least 8 mA with the variable resistor and start timing with a suitable timing device. (The 8 mA is a minimum current value. Higher current levels may be specified. The current used shall be reported.)

3126.5 When the current drops to 2 mA or at the end of 30 min, whichever occurs first, disconnect the current source and gently wash the electrodes with a smooth, thin stream of distilled water.

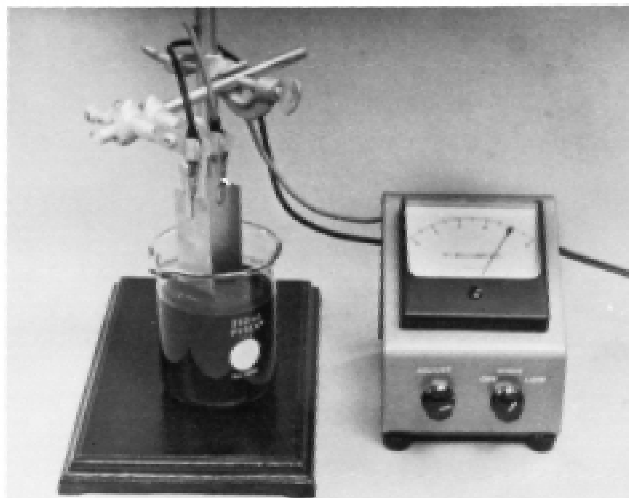
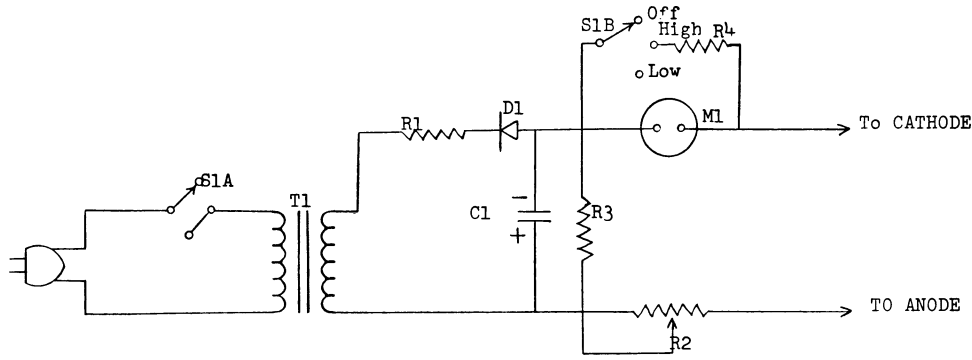

FIG. 5 Particle Charge Tester



C1—500 μ F 25-V capacitor
 D1—silicon diode
 R1—47 Ω , 1-W resistor
 R2—5000 Ω potentiometer
 R3—6800 Ω , 1/4-W resistor

R4—meter shunt (determined by type of meter used)
 S1—2-pole, 3-position rotary switch
 T1—12.6-V filament transformer
 M1—0 to 10-mA milliammeter

FIG. 6 Particle Charge Tester Circuit Diagram

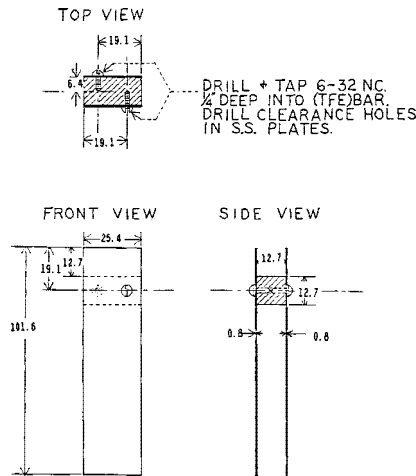

FIG. 7 Insulator

31.26.6 Observe the asphalt deposit on the electrodes. A cationic emulsion will deposit a discernible amount of asphalt on the cathode (negative electrode) while the anode (positive electrode) will be relatively clean. Any evidence of a deposit of asphalt on the cathode which is clearly discernible when compared to the anode is to be considered passing.

NOTE—10—If 9—If the emulsion does not produce conclusive results and it is a cationic slow-setting grade, then proceed to Section 1050, "Identification of Cationic Slow-Set Emulsion."

327. Report

327.1 Report the following information:

327.1.1 Level of current used, and

327.1.2 Whether the tested emulsion passes or fails as defined in 31.6.

33. 26.6.

28. Precision and Bias

33.28.1 This test method, which requires subjective evaluation of test results and reporting of only two possible conditions, does not lend itself readily to a conventional statistical round-robin exercise. At present, there is no precision and bias statement for this test method.

CONSISTENCY
VISCOSITY

~~34.~~

29. Scope

3429.1 This test method utilizes the Saybolt Furol viscometer to measure the consistency of an asphalt emulsion. It is applicable to all the emulsions specified in Specifications D 977 and D 2397.

350. Significance and Use

350.1 Viscosity has significance in the use of asphalt emulsions because it is a property which affects their utility. When used in application types of construction, the material must be thin enough to be uniformly applied through the spray bar of distributor, yet thick enough so that it will not flow from the crown or grade of the road. For mixing grade emulsions, the viscosity may affect mixability and resulting thickness of film on the aggregate. The viscosity of many emulsions is affected by shear. Therefore, strict adherence to test procedure is necessary to achieve precision.

361. Apparatus

361.1 *Viscometer*—A Saybolt Furol viscometer conforming to the requirements specified in Test Method D 88.

361.2 *Sieve*—A 850- μm sieve or a 20-mesh strainer of wire cloth, framed or unframed.

361.3 *Thermometers*—ASTM No. 17C or 17F for tests at 25°C and ASTM No. 19F or 19C for tests at 50°C, conforming to the requirements of Specification E 1.

361.4 *Water Bath*, capable of maintaining the required testing temperature within the limits specified in Table 2 of Test Method D 88.

372. Procedure

372.1 *Tests at 25°C*—Stir the sample thoroughly without incorporating bubbles and pour it into a 118-mL bottle. Place the bottle in the water bath at 25°C for 30 min and mix the sample in the bottle by inverting it several times slowly enough to prevent bubble formation. Pour the sample into the viscometer through the 850- μm sieve or 20-mesh strainer, allowing a small portion to flow through the outlet tube to waste. Place the cork in position, fill the viscometer and, without again stirring the sample, determine the viscosity as prescribed in Test Method D 88.

372.2 *Tests at 50°C*—Clean and dry the viscometer and insert the cork. Heat the emulsion sample to $122 \pm 5^\circ\text{F}$ ($50 \pm 3^\circ\text{C}$) in a $160 \pm 5^\circ\text{F}$ ($71 \pm 3^\circ\text{C}$) water bath or oven. Stir the sample thoroughly without incorporating bubbles, and then pour approximately 100 mL into a 400-mL glass beaker. Immerse the bottom of the beaker containing the emulsion approximately 2 in. (50.8 mm) below the level of a $160 \pm 5^\circ\text{F}$ ($71 \pm 3^\circ\text{C}$) water bath. Hold the beaker upright and stir the emulsion with a wide circular motion at a rate of 60 revolutions per minute with the thermometer to obtain uniform temperature distribution. Avoid incorporation of bubbles. Heat the emulsion in the water bath to $124.5 \pm 0.5^\circ\text{F}$ ($51.4 \pm 0.3^\circ\text{C}$). Immediately pour the emulsion through the 850- μm (No. 20) sieve or 20-mesh strainer into the viscometer until it is above the overflow rim. Stir the emulsion in the viscometer at 60 revolutions per minute with the thermometer until the test temperature is attained, avoiding bubble formation. Adjust the bath temperature until the emulsion temperature remains constant for 1 min at $50 \pm 0.05^\circ\text{C}$. Withdraw the thermometer. Quickly remove the excess emulsion from the gallery with a suction pipet. Determine the viscosity as described in Test Method D 88. Report the results to the nearest full second.

NOTE 1H0—While the Saybolt Furol viscometer is not used for petroleum products and lubricants when the time of flow is less than 25 s, this instrument is satisfactory for testing emulsified asphalt when the time of flow is not less than 20 s.

383. Precision and Bias

383.1 The following criteria should be used for judging the acceptability of results (95 % probability):

383.1.1 Duplicate results by the same operator should not be considered suspect unless they differ by more than the following amount:

Test Temperature, °C	Viscosity, s	Repeatability, % of the mean
25	20 to 100	5
50	75 to 400	9.6

383.1.2 The results submitted by each of two laboratories should not be considered suspect unless they differ by more than the following amount:

Test Temperature, °C	Viscosity, s	Reproducibility, % of the mean
25	20 to 100	15
50	75 to 400	21

STABILITY

DEMULSIBILITY

394. Scope

394.1 This test method, applicable to anionic and cationic emulsions of the RS and MS type, measures the chemical breaking of the emulsion.

~~40.~~

35. Significance and Use

~~40~~35.1 This test method is used to identify or classify an emulsion as an RS or MS by measuring the amount of available asphalt that is broken from the emulsion by utilizing specified amounts and concentrations of calcium chloride solution for anionic emulsions and dioctyl sodium sulfosuccinate for cationic emulsions.

~~41.~~

36. Apparatus and Reagents

~~41.1~~

~~36.1~~ *Wire Cloth*—Three pieces of 1.40-mm wire cloth approximately 125 mm square, unframed, having wire diameters and openings that conform to Specification E 11.

~~41.2~~

~~36.2~~ *Beakers*—Three metal beakers of 600-mL capacity each.

~~41.3~~

~~36.3~~ *Rods*—Three metal rods with rounded ends, approximately (7.9 mm) in diameter.

~~41.4~~

~~36.4~~ *Buret*—A 50-mL glass buret graduated in 0.1-mL intervals.

~~41.5~~

~~36.5~~ *Calcium Chloride Solution* (1.11 g/L)—Dissolve 1.11 g of calcium chloride (CaCl₂) in water and dilute to 1 L. The 1.11 g/L calcium chloride solution shall be standardized to be a 0.02 N ± 0.001 normal solution of calcium chloride in water.

~~41.6~~

~~36.6~~ *Calcium Chloride Solution* (5.55 g/L)—Dissolve 5.55 g of CaCl₂ in water and dilute to 1 L. The 5.55 g/L calcium chloride solution shall be standardized to be a 0.1 N ± 0.001 normal solution of calcium chloride in water.

~~41.7~~

~~36.7~~ *Dioctyl Sodium Sulfosuccinate Solution* (0.8%)—Dissolve 8.00 g of dioctyl sodium sulfosuccinate in 992 g of water.

~~41.8~~

~~36.8~~ *Balance*, capable of weighing 500 g to within ±0.1 g.

~~42.~~

37. Procedure

~~42~~37.1 Determine the percentage of residue by distillation as described in Section 14.

~~42~~37.2 Record the weight of each assembly of beaker, rod, and wire cloth.

~~42~~37.3 Weigh 100 ± 0.1 g of the emulsified asphalt into each of three 600-mL beakers in the weighed assemblies. Bring the weighed sample of emulsion and the proper reagent to a temperature of (25 ± 0.5°C). Over a period of approximately 2 min, add to each beaker, from a buret, 35 mL of CaCl₂ solution (1.11 g/L) (Note—~~H~~ 10) for rapid setting emulsions, or 50 mL of CaCl₂ solution (5.55 g/L) for mixing-type emulsions. While adding the CaCl₂ solution, stir the contents of the beaker continuously and vigorously, kneading any lumps against the sides of the beaker to ensure thorough mixing of the reagent with the emulsion. Continue kneading any lumps for an additional 2 min after the addition of the CaCl₂ solution.

NOTE 121—When testing cationic emulsions, use 35 mL of dioctyl sodium sulfosuccinate solution (0.8 %) instead of 35 mL of CaCl₂ solution (1.11 g/L).

~~42~~37.4 Decant the mixture of any unbroken emulsion and reagent onto the wire cloth. Rinse the beaker containing the sample and metal rod with distilled water. Knead and break up all lumps, and continue washing the beaker, rod, and wire cloth until the wash water drains clear. Place the wire cloth enclosing the asphalt in the beaker with the metal rod. Place the assembly in a 163°C drying oven and dry to constant weight.

438. Calculation

~~438~~.1 Subtract the tare weight of the beaker, rod, and wire cloth from the weight of the dried assembly to obtain the

demulsibility residue. Calculate the demulsibility as follows:

$$\text{Demulsibility, \%} = (A/B) \times 100 \quad (3)$$

where:

A = average weight of demulsibility residue from the three tests of each sample of emulsified asphalt, and

B = weight of residue by distillation in 100 g of the emulsified asphalt.

~~44.~~

39. Precision and Bias

4439.1 The following criteria should be used for judging the acceptability of results of tests on RS emulsions (95 % probability):

NOTE 132—Precision does not apply when using dioctyl sodium sulfosuccinate solution in the testing of cationic emulsions for demulsibility.

4439.1.1 Duplicate results by the same operator should not be considered suspect unless they differ by more than the following amount:

Demulsibility, weight % 30 to 100	Repeatability, % of the mean 5
--------------------------------------	-----------------------------------

4439.1.2 The results submitted by each of two laboratories should not be considered suspect unless they differ by more than the following amount:

Demulsibility, weight % 30 to 100	Reproducibility, % of the mean 30
--------------------------------------	--------------------------------------

SETTLEMENT

450. Scope

450.1 This test method measures the settlement of an emulsified asphalt that occurs in a cylindrical container.

461. Significance and Use

461.1 This test method is a measure of the uniformity of an emulsified asphalt dispersion in storage over a period of time.

472. Apparatus

472.1 *Cylinders*—Two 500-mL glass cylinders, with pressed or molded glass bases and cork or glass stoppers, having an outside diameter of 50 ± 5 mm.

472.2 *Glass Pipet*—A 60-mL siphon glass-tube pipet of optional form.

472.3 *Balance*, capable of weighing 500 g to within ± 0.1 g.

483. Procedure

483.1 Place a 500-mL representative sample in each of the two glass cylinders. Stopper the cylinders and allow them to stand undisturbed at laboratory air temperature for 5 days. After standing for this period, remove approximately the top 55 mL of emulsion by means of a pipet or siphon without disturbing the balance. Mix each portion thoroughly. Weigh 50 g of each sample into separate weighed 1000-mL low-form glass beakers, and determine the asphaltic residue by evaporation in accordance with Section ~~24~~ 19.

483.2 After removal of the top sample, siphon off approximately the next 390 mL from each of the cylinders. Thoroughly mix the emulsion remaining in the cylinders and weigh 50 g into separate weighed 1000-mL low-form beakers. Determine the asphaltic residue of these samples in accordance with Section ~~24~~ 19.

NOTE 143—If the emulsion contains appreciable amounts of oil distillate as determined by distillation (see 14.6), the settlement value may be calculated from the difference in the percentage of water content between the top and bottom samples as determined by the procedure described in Section 8.

494. Calculation and Report

494.1 Calculate the settlement for each cylinder as follows:

$$\text{Settlement, \% (5 days)} = B - A \quad (4)$$

where:

A = the percentage of residue from the top samples, and

B = the percentage of residue from the bottom samples.

NOTE 154—If the settlement values between the two cylinders differ by more than the stated repeatability, the result is considered suspect and the test shall be repeated. If for individual cylinders the percent residue of both the top and bottom samples is less than the percent residue of the emulsion, the result is considered suspect and the test shall be repeated. If for individual cylinders the percent residue of both the top and bottom samples is greater than the percent residue of the emulsion, the result is considered suspect and the test shall be repeated.

494.2 Report the settlement as the average of the two individual cylinder results.

450. Precision and Bias

450.1 The following criteria should be used for judging the acceptability of results (95 % probability):

450.1.1 Duplicate results by the same operator should not be considered suspect unless they differ by more than the following amount:

Settlement, weight %	Repeatability
0 to 1.0	0.4 weight %
above 1.0	5 % of the mean

450.1.2 The results submitted by each of two laboratories should not be considered suspect unless they differ by more than the following amount:

Settlement, weight %	Reproducibility
0 to 1.0	0.8 weight %
above 1.0	10 % of the mean

CEMENT MIXING

~~51.~~

46. Scope

5146.1 This test method is a mixing test used to identify or classify a slow setting, SS or CSS, type of emulsion.

~~52.~~

47. Significance and Use

5247.1 The result of this test indicates the ability of a slow setting emulsified asphalt to mix with a finely divided, high surface area material (high early strength, Type III, portland cement) without breaking the emulsion.

~~53.~~

48. Apparatus

~~53.1~~

48.1 *Sieves*—A 180- μ m sieve and a 3-in. (76.2-mm) diameter 1.4-mm sieve, made of wire cloth conforming to Specification E 11.

~~53.2~~

48.2 *Dish*—A round-bottom iron dish or a kitchen saucepan of approximately 500-mL capacity.

~~53.3~~

48.3 *Stirring Rod*—A steel rod with rounded ends, approximately 13 mm in diameter.

~~53.4~~

48.4 *Graduate*—A 100-mL graduated cylinder.

~~53.5~~

48.5 *Balance*, capable of weighing 500 g to within ± 0.1 g.

549. Cement

549.1 High-early-strength portland cement conforming to the requirements for Type III portland cement in Specification C 150 and having a minimum specific surface area of 1900 cm²/g, as measured by the Wagner Turbidimeter.

550. Procedure

550.1 Dilute the emulsion with distilled water to a residue of 55 %, as determined by distillation or by evaporation for 3 h at 163°C.

550.2 Sieve a portion of the cement through the 180- μ m sieve. Weigh 50 ± 0.1 g of the cement passing the No. 80 (180- μ m) sieve into the iron dish or saucepan.

550.3 Bring the ingredients and apparatus to a temperature of approximately 25°C before mixing. Add 100 mL of the diluted emulsion to the cement and stir the mixture at once with the steel rod, using a circular motion at a rate of 60 revolutions per minute. At the end of the 1-min mixing period, add 150 mL of distilled water, and continue the stirring for 3 min.

550.4 Pour the mixture through a weighed 1.4-mm sieve. Use repeated washings to completely remove material from the mixing bowl. Pour these over the sieve, and rinse the sieve using distilled water held at a height of approximately 152 mm until the water is clear. Place the sieve in a weighed shallow pan, heat at 163°C in an oven, and weigh. Repeat the heating and weighing until successive weights differ by no more than 0.1 g.

561. Report

561.1 Report the weight, in grams, of the material retained on the sieve and in the pan as the percentage of break in the cement mixing test.

572. Precision and Bias

572.1 The following criteria should be used for judging the acceptability of results (95 % probability):

572.1.1 Duplicate results by the same operator should not be considered suspect unless they differ by more than the following amount:

Cement Mixing, weight %
0 to 2

Repeatability, weight %
0.2

572.1.2 The results submitted by each of two laboratories should not be considered suspect unless they differ by more than the following amount:

Cement Mixing, weight %
0 to 2

Reproducibility, weight %
0.4

SIEVE TEST

583. Scope

583.1 This test method measures the degree to which an emulsified asphalt may contain particles of asphalt or other discreet solids retained on a 850 µm mesh sieve.

594. Significance and Use

594.1 The retention of an excessive amount of particles on the sieve indicates that problems may occur in handling and application of the material. Particles of asphalt retained on the sieve often are caused by agglomeration of the dispersed phase. Storage, pumping, handling, and temperature can all contribute to the formation of particles. Contamination from the tank, transport, or hose are other factors affecting particle formation.

~~60.~~

55. Apparatus and Reagents

~~60.1~~

55.1 *Sieve*—A sieve having a 76.2-mm frame conforming to 76.2 mm of Specification E 11, and having a 850-µm wire sieve cloth.

~~60.2~~

55.2 *Pan*—A tin box cover or shallow metal pan of appropriate size to fit over the bottom of the standard sieve.

~~60.3~~

55.3 *Sodium Oleate Solution (2 %)*—Dissolve 2 g of pure sodium oleate in distilled water and dilute to 100 mL.

NOTE 165—Replace sodium oleate solution with distilled water in testing cationic emulsions.

~~60.4~~

55.4 *Balances*, capable of weighing 2000 g to within ±1 g, and 500 g to within ±0.1 g.

561. Procedure

561.1 The temperature at which the sieve test should be performed is related to the emulsion viscosity. For those materials whose viscosity is 100 s or less at 25°C, perform the test at room temperature. For those materials whose viscosity is more than 100 s at 25°C and those whose viscosity is specified at 50°C, use a test temperature of 50 ± 3°C. If heating is necessary the emulsion, in a closed container, may be placed in an oven or water bath, followed by stirring to achieve homogeneity.

561.2 Record the weight of the sieve and pan and wet the wire cloth with the 2 % sodium oleate solution. Weigh 1000 g of the emulsified asphalt into a suitable container and pour it through the sieve. Wash the container and the residue on the sieve with the sodium oleate solution until the washings run clear. Place the pan under the sieve and heat for 2 h in a 105°C drying oven. Cool in a desiccator, and weigh the sieve, pan and residue.

~~62.~~

57. Calculation

6257.1 Calculate the percentage of sample retained on the sieve as follows:

$$\text{Sample retained, \%} = (B - A)/10 \quad (5)$$

where:

A = weight of sieve and pan, g, and

B = weight of sieve, pan, and residue, g.

~~63.~~

58. Precision and Bias

6358.1 The following criteria should be used for judging the acceptability of results (95 % probability):

~~6358.1.1~~ Duplicate results by the same operator should not be considered suspect unless they differ by more than the following amount:

Sieve Test, weight %
0 to 0.1

Repeatability, weight %
0.03

~~6358.1.2~~ The results submitted by each of two laboratories should not be considered suspect unless they differ by more than the following amount:

Sieve Test, weight %
0 to 0.1

Reproducibility, weight %
0.08

COATING TEST

~~64.~~

59. Scope

~~6459.1~~ This practice is applicable to those emulsions intended for use by mixing with aggregate. It is not applicable to rapid-setting types or diluted materials used for tack coats, priming or mulch treatments.

650. Significance and Use

~~650.1~~ The intent of the coating test is to ensure that a given mixing grade emulsion is stable enough as an emulsion and otherwise possesses the ability to mix with a reference stone for the prescribed time and coat it uniformly and thoroughly.

661. Apparatus and Material

~~661.1~~ *Sieves*—Standard 19.0-mm and 6.3-mm sieves conforming to Specification E 11.

~~661.2~~ *Spatula*—A steel spatula or its equivalent, having a blade approximately 203.2 mm in length.

~~661.3~~ *Dish*—A round-bottom iron dish or a kitchen saucepan, of approximately 1-L capacity.

~~661.4~~ *Stone*—A supply of reference stone (hard limestone, trap rock, or other type) which has been washed with water and dried before using. All stone shall pass through the standard 19.0-mm screen and not more than 5 % shall pass through the 6.3-mm screen.

~~NOTE 176~~—Each laboratory shall select its own reference stone supply, the source of which is not apt to change; this is to obviate rapid changes in the character of reference stone used in any one laboratory.

~~661.5~~ *Balance*, capable of weighing 1000 g to within ± 0.1 g.

672. Procedure

~~672.1~~ Weigh 465.0 ± 0.1 g of stone into the metal pan. Add 35.0 ± 0.1 g of the emulsion to the stone in the pan, and mix vigorously with the spatula for 3 min.

~~672.2~~ Record whether or not there is appreciable separation of the asphaltic base from the water of the emulsion, and whether or not the stone is uniformly and thoroughly coated with the emulsion.

MISCIBILITY WITH WATER

683. Scope

~~683.1~~ This practice may be applied to all medium and slow-setting asphalt emulsions. It is not applicable to the rapid-setting types.

694. Significance and Use

~~694.1~~ It is sometimes desirable to dilute an emulsified asphalt in the field with water. This test is designed to ascertain if this may be done safely without breaking the emulsion.

~~70.~~

65. Procedure

~~7065.1~~ Gradually add 150 mL of distilled water, with constant stirring, to 50 mL of the emulsion in a 400-mL glass beaker. The temperature should be between 21 and 25°C. Allow the mixture to stand for 2 h; then examine it for any appreciable coagulation of the asphalt content of the emulsion.

FREEZING TEST

~~71.~~

66. Scope

~~7166.1~~ Emulsified asphalt is normally damaged by freezing temperatures, but specially formulated materials are expected to pass this practice.

672. Significance and Use

672.1 Certain agencies, who desire to use, store or transport emulsified asphalt under less than ideal weather conditions, may require that the product remain homogeneous (unbroken) after being subjected to temperatures of -17.8°C .

~~73.~~

68. Procedure

7368.1 Place approximately 400 g of the emulsion in a clean metal container, such as a 500-mL press-top can.

7368.2 Expose the emulsion in the closed container to an air temperature of -17.8°C for 12 (or more) consecutive hours.

7368.3 At the expiration of the freezing period, permit the emulsion to thaw by exposure of the container to ambient temperature.

7368.4 Repeat the freezing and thawing periods until the emulsion will have been subjected to three cycles of freezing and thawing.

7368.5 After the third cycle, the emulsion may be homogeneous or may have separated into distinct layers which cannot be rendered homogeneous by stirring at laboratory temperature.

7368.6 Report the result of this test as either “Homogeneous” or “Broken.”

COATING ABILITY AND WATER RESISTANCE

~~74.~~

69. Scope

7469.1 This test method is intended to aid in the identification of asphalt emulsions suitable for mixing with coarse graded calcareous aggregates. It can be applied to other aggregates. (See Note 187).

750. Significance and Use

750.1 This test method covers the determination of the ability of an asphalt emulsion to (1) coat an aggregate thoroughly, (2) withstand a mixing action while remaining as a film on the aggregate, and (3) resist the washing action of water after completion of the mixing.

761. Apparatus

761.1 *Mixing Pan*—A white-enameled kitchen saucepan with handle, of approximately 3-L capacity.

761.2 *Mixing Blade*—A putty knife with a 31.8 by 88.9-mm steel blade with rounded corners. A 254.0-mm kitchen mixing spoon may be used as an alternative.

761.3 *Sieves*—Standard 19.0-mm and 4.75-mm sieves conforming to Specification E 11.

761.4 *Constant-Head Water-Spraying Apparatus*—An apparatus for applying tap water in a spray under a constant head of 774.7 mm (Figs. 8 and 9). The water shall issue from the apparatus in a low-velocity spray.

761.5 *Thermometer*—An ASTM Low Softening Point Thermometer 15F (or 15C), having a range from -2 to 80°C and conforming to the requirements in Specification E 1.

761.6 *Balance*, capable of weighing 1000 g to within ± 0.1 g.

761.7 *Pipet*, of 10-mL capacity.

772. Materials

772.1 *Aggregate*—Standard reference aggregate¹⁰ shall be a laboratory-washed and air-dried limestone aggregate graded to pass the 19.0-mm sieve and be retained on the 4.75-mm sieve.

NOTE 187—Aggregates other than limestone may be used provided calcium carbonate is omitted throughout the test method. Laboratory washing and air-drying of such aggregates shall also be omitted.

772.2 *Calcium Carbonate*—Chemically pure, precipitated calcium carbonate (CaCO_3) shall be used as a dust to be mixed with the standard reference aggregate.

772.3 *Water*—Tap water of not over 250 ppm CaCO_3 hardness for spraying over the sample.

783. Sample

783.1 The sample shall be representative of the asphalt emulsion to be tested.

794. Procedure for Tests with Dry Aggregate

794.1 Carry out the test at $23.9 \pm 5.5^{\circ}\text{C}$.

794.2 Weigh 461 g of the air-dried, graded reference aggregate in the mixing pan.

794.3 Weigh 4.0 g of CaCO_3 dust in the mixing pan and mix with the 461 g of aggregate for approximately 1 min by means of a mixing blade to obtain a uniform film of dust on the aggregate particles.

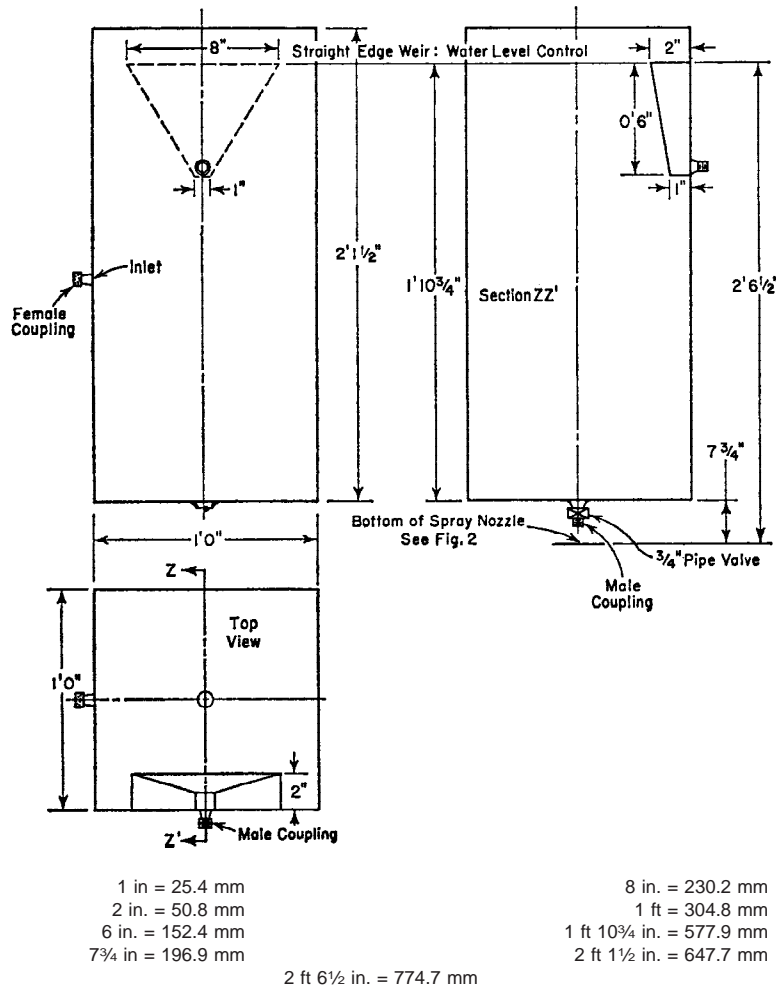

FIG. 8 Constant-Head Flow Tank

NOTE 1—Use galvanized steel sheeting for the tank. All joints and fitting attachments shall be soldered and shall be watertight. All couplings shall be standard brass garden hose fittings. The 19-mm pipe valve shall be placed as close as possible to the bottom of the tank, allowing space to shut off the valve. The tank shall be placed on a suitable stand, so that the distance from the bottom of the spray head to the top of the test sample is 0.914 m ± 25.4 mm.

NOTE 198—The total weight of aggregate and dust shall equal 465 g. If no calcium carbonate is included, the weight of aggregate alone shall be 465 g.

794.4 Weigh 35 g of the asphalt emulsion into the aggregate in the pan and mix vigorously with the mixing blade for 5 min using a tossing action created by a back-and-forth motion in an elliptical path of the mixing blade or spoon. At the end of the mixing period, tilt the pan and permit any excess emulsion not on the aggregate to drain from the pan.

794.5 Remove approximately one half of the mixture from the pan and place it on absorbent paper and evaluate the coating.

794.6 Immediately spray the mixture remaining in the pan with tap water from the constant-head water spraying apparatus to cover the mixture. The distance from the sprayhead to the sample shall be 305 ± 75 mm. Then carefully pour off the water. Continue spraying and pouring off the water until the overflow water runs clear. Carefully drain off the water in the pan. Scoop the mixture from the mixing pan on to absorbent paper for evaluation of coating retention in the washing test.

794.7 Evaluate the mixture immediately by visual estimation as to the total aggregate surface area that is coated with asphalt.

794.8 Repeat the evaluation by visual estimation of the coating of aggregate surface area by asphalt after the mixture has been surface air-dried in the laboratory at room temperature. A fan may be used for drying if desired.

80.—

75. Procedure for Tests with Wet Aggregate

8075.1 Proceed in accordance with 794.1-794.3.

8075.2 Pipet 9.3 mL of water to the aggregate and CaCO₃ dust mixture into the mixing pan and mix thoroughly to obtain uniform wetting.

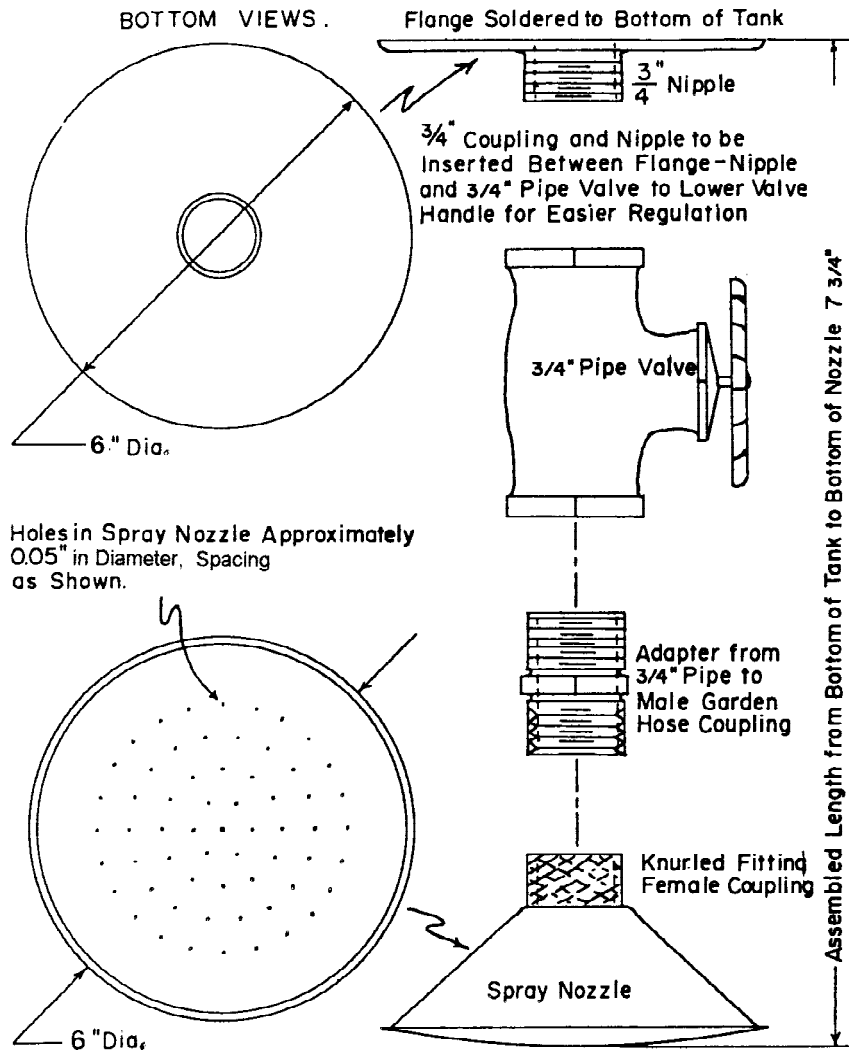

NOTE 1—A Speakman, Model 235S, all brass, fixed shower head has been found acceptable.
 NOTE 2—Existing 101.6-mm diameter shower heads may continue to be used.
 NOTE 3—0.05 in. = 1.3 mm
 6 in. = 152.4 mm
 7 3/4 in. = 196.9 mm

FIG. 9 Valve and Nozzle Assembly for Constant-Head Flow Tank

8075.3 Continue in accordance with 79.4-79.8.

81- 74.4-74.8.

76. Interpretation of Results

8176.1 Evaluate and report the following information for tests with both dry and wet aggregate:

8176.1.1 At the end of the mixing period, record the coating of the total aggregate surface area by the asphalt emulsion as good, fair, or poor, where a rating of "good" means fully coated by the asphalt emulsion exclusive of pinholes and sharp edges of the aggregate, a rating of "fair" coating applies to the condition of an excess of coated area over uncoated area, and a rating of "poor" applies to the condition of an excess of uncoated area over coated area.

8176.1.2 After spraying with water, record the coating of the total aggregate surface area by the asphalt as good, fair, or poor.

8176.1.3 After air-drying in the laboratory, record the coating of the total aggregate surface area by the asphalt as good, fair, or poor.

8176.1.4 Comments about the results of the test may be included in the evaluation.

STORAGE STABILITY OF ASPHALT EMULSION

~~82.~~

77. Scope

8277.1 This test method relates to the ability of an asphalt emulsion to remain as a uniform dispersion during storage. It is applicable to asphalt emulsions composed principally of a semisolid or liquid asphaltic base, water, and an emulsifying agent.

783. Summary of Test Method

783.1 This test method determines the difference in percent residue of samples taken from the top and bottom of material placed in undisturbed simulated storage for 24 h. The result is expressed as the average of the two individual values obtained by determining the difference between the percent residue of the top and bottom samples for each storage cylinder.

~~84.~~

79. Significance and Use

8479.1 This test method is useful for determining in a comparatively short time the storage stability of an asphalt emulsion. It is a measure of the permanence of the dispersion as related to time, but it is not to be construed to have significance as a measure of other stability aspects involved in use.

850. Apparatus

850.1 *Cylinders*—Two 500-mL glass cylinders, with pressed or molded glass bases and cork or glass stoppers, having an outside diameter of 50 ± 5 mm, and having 5-mL graduations.

850.2 *Glass Pipet*—A 60-mL siphon glass-tube pipet of optional form.

850.3 *Balance*, capable of weighing 500 g to within ± 0.1 g.

861. Procedure

861.1 Bring the asphalt emulsion to room temperature, 21 to 27°C. Place a 500-mL representative sample in each of the two glass cylinders. Stopper the cylinders and allow them to stand undisturbed, at laboratory air temperature 21 to 27°C, for 24 h. After standing for this period, remove approximately 55 mL from the top of the emulsion by means of the pipet or siphon without disturbing the balance. Thoroughly mix each portion.

861.2 Weigh 50.0 ± 0.1 g of each sample into separately weighed 1000-mL glass or aluminum beakers, each beaker having previously been weighed with a 6-mm diameter by 178-mm glass rod. Adjust the temperature of the oven to 163 ± 2.8 °C. Then place the beakers containing the rods and sample in the oven for 2 h. At the end of this period remove each beaker and thoroughly stir the residue. Replace in the oven for 1 h, then remove the beakers from the oven, allow to cool to room temperature, and weigh with the rods (see Note ~~7~~ 6).

861.3 After removal of the top sample, siphon off the next 390 mL (approximate) from each of the cylinders. Thoroughly mix the emulsion remaining in the cylinders and weigh 50 g into separate weighed 1000-mL glass or aluminum beakers. Determine the asphaltic residue of these samples in accordance with 861.2.

872. Calculation and Report

872.1 Calculate and report the storage stability in accordance with Section ~~49~~ 44, and observe Note 154.

883. Precision and Bias

883.1 *Repeatability*—The repeatability standard deviation is 0.2 %. The average difference between two results, obtained by the same operator with the same equipment, but not concurrently, will be approximately 0.2 %. Two such values should be considered suspect (95 % confidence level) if they differ by more than 0.5 %.

883.2 *Reproducibility*—The reproducibility standard deviation is 0.2 %. The average difference between two results obtained by operators in different laboratories will be approximately 0.3 %. Two such values should be considered suspect (95 % confidence level) if they differ by more than 0.6 %.

~~NOTE—20—If 19—~~If this test method is performed using only one cylinder instead of two for each determination as specified in the test method, then the following precision criteria should be used:

	Repeatability, %	
Standard deviation		0.2
Average difference		0.3
Suspect criterion		0.5
	Reproducibility, %	
Standard deviation		0.2
Average difference		0.3
Suspect criterion		0.6

EXAMINATION OF RESIDUE

894. Scope

894.1 Tests for specific gravity, ash content, solubility in trichloroethylene, penetration, ductility and float test are suggested for examination of the emulsion residue obtained by distillation or evaporation (14.7 and ~~25.2~~)

~~90. 20.2)~~

85. Significance and Use

9085.1 The suggested procedures are used to characterize and evaluate the properties of emulsion residues.

~~91.~~

86. Specific Gravity

9186.1 Determine the specific gravity on a representative portion of the residue in accordance with Test Method D 70 or Test Method D 3289.

~~92.~~

87. Ash Content

9287.1 Determine the ash on a representative portion of the residue in accordance with the rapid routine test method of ash determination, as described in Section 7 of Test Methods D 128.

~~93.~~

88. Solubility in Trichloroethylene

9388.1 Determine the solubility in trichloroethylene on a representative portion of the residue in accordance with Test Method D 2042.

894. Penetration

894.1 Determine the penetration on a representative portion of the residue in accordance with Test Method D 5.

894.2 *Precision*—The following criteria should be used for judging the acceptability of results (95 % probability):

894.2.1 Duplicate results by the same operator should not be considered suspect unless they differ by more than the following amount:

Penetration of Residue, range 80 to 200	Repeatability, points 15
--	-----------------------------

894.2.2 The results submitted by each of two laboratories should not be considered suspect unless they differ by more than the following amount:

Penetration of Residue, range 80 to 200	Reproducibility, points 30
--	-------------------------------

950. Ductility

950.1 Determine the ductility on a representative portion of the residue in accordance with Test Method D 113.

961. Float Test

961.1 Determine the float test on a representative portion of the residue in accordance with Test Method D 139 except revise 6.2 of Test Method D 139 as follows: Pour the residue into the collar at or near 260°C preferably, directly from the still. If the residue has been allowed to cool below 260°C, reheat it to 260°C with stirring and pour into the collar.

PRACTICE FOR THE IDENTIFICATION TEST FOR RAPID-SETTING CATIONIC EMULSIFIED ASPHALT
972. Scope

972.1 This practice covers a procedure for identifying rapid-setting cationic emulsified asphalts. Their inability to coat a specific silica sand distinguishes them from medium and slow setting cationic grades.

983. Significance and Use

983.1 This practice is based upon the rapid asphalt deposition properties of rapid setting cationic emulsified asphalt as a function of sand surface area and surface charge. The test method differs from the usual coating test because the material passes the requirement when it fails to coat the specified silica sand.

983.2 Impurities in the silica sand often prevent the emulsion from passing the test. Washing the sand to remove impurities prior to test is required. Impurities affecting test results are normally due to the presence of iron (Fe⁺⁺⁺) and organic dewatering agents that can alter sand surface charge.

994. Apparatus

994.1 *Mixing Container*—Glass beaker or stainless steel beaker or bowl, 1000 mL capacity.

994.2 *Washing Container*—Beaker made from borosilicate glass, 1000 mL capacity.

994.3 *Stainless Steel Spatula or Glass Rod*.

994.4 *Oven*—Convection or forced-draft, capable of maintaining 120 to 150°C.

994.5 *Balance*—Capable of weighing 500 ± 0.1 g.

994.6 *Drying Pan*—Stainless steel or glass, 150-mm by 225-mm or larger.

994.7 *Graduated Cylinder*—Made from borosilicate glass, 500-mL capacity.

994.8 *Thermometer*—ASTM No. 67C or as specified in Table 1 of Specification E 1.

994.9 *Eye Protection*—Suitable safety glasses or other appropriate eye protection.

994.10 *Hand Protection*—Suitably acid and alcohol resistant.

~~100.~~

95. Materials

~~100.1~~

95.1 *Silica Sand*, F-95, whole grain.

~~100.2~~¹¹

95.2 *Hydrochloric Acid*, reagent, 36.5 % to 38.0 %.

~~100.3~~

95.3 *Isopropyl Alcohol*, reagent, 100 %.

~~100.4~~

95.4 *Distilled Water*.

TYPICAL GRADATION

Millimetres	0.850	0.425	0.300	0.212	0.150	0.106	0.075	0.053
% Passing	100	99	97	89	56	17	2	T

~~101.~~

96. Emulsified Asphalt (Emulsion) Sample

~~101~~96.1 Obtain a representative sample of the rapid-setting cationic emulsion for test.

~~102.~~

97. Sand Preparation

~~102~~97.1 Prepare 400 mL of 5 % hydrochloric acid, by volume, in isopropyl alcohol by mixing 20 mL hydrochloric acid into a blend of 80 mL distilled water and 300 mL isopropyl alcohol in a 500 mL graduated cylinder.

~~102~~97.2 Weigh 500 g of the F-95 silica sand into a 1000 mL beaker. Add 400 mL of the 5 % hydrochloric acid in isopropyl alcohol/water mixture into the beaker containing the silica sand and stir for 5 min with a stainless steel spatula or a glass rod.

~~102~~97.3 Decant the acid/alcohol/water mixture carefully without loss of sand.

~~102.4~~ Wash

97.4 Wash sand with at least 400 mL of hot distilled water, 50° to 70°C stir for approximately 1 min. Decant water without loss of sand. Repeat water washing the sand two more times.

~~102~~97.5 Scrape washed sand onto drying pan avoiding as much loss of sand as is possible and spread sand over the surface of the drying pan. Place pan with sand in an oven and dry the sand at a temperature of 120 to 150°C to constant mass.

~~10297.6~~ Allow sand to cool and transfer dry sand to a suitable container. Mix sand for approximately 30 s to obtain uniformity.

~~103.~~

98. Procedure

~~103.1~~ Test

~~98.1~~ Test at $25 \pm 5^\circ\text{C}$.

~~10398.2~~ Weigh 465 g of the washed silica sand blend into a 1000 mL beaker. Add 35 g of the emulsion to be tested and mix vigorously with a spatula for approximately 2 min using a combined stirring and kneading action. At the end of the mixing period, tilt the beaker and allow any excess emulsion, which is not on the sand, to drain from the beaker.

~~10398.3~~ Place the completed mix on absorbent paper. Visually estimate the amount of uncoated and coated area in the mixture. See Note ~~21~~.

~~104.~~ **20.**

99. Interpretation of Results

~~104.1~~ From

~~99.1~~ From the visual estimation of the amount of uncoated area and coated area in the mixture, record the coating of the total sand surface area by the asphalt emulsion. An excess of uncoated area over the coated area shall be considered as a passing rating for identification of rapid-setting cationic emulsified asphalt.

NOTE ~~210~~—Visual estimation is less accurate at moderate levels of coating than at the two extremes. If results are inconclusive, the washing and mixing procedure should be repeated.

IDENTIFICATION OF CATIONIC SLOW-SET EMULSIONS

1050. Scope

~~1050.1~~ This practice is intended to identify a cationic slow-setting grade of emulsified asphalts if the results of the particle charge test are inconclusive.

1061. Summary of Practice

~~1061.1~~ A weighed amount of washed and dried silica sand is hand mixed with a weighed amount of emulsified asphalt. Mixing time should extend until aggregate is completely coated. The amount of CSS-grade emulsified asphalt in the mix should give a total mix asphalt content of about 5.0 %. The sample is spread out and allowed to air cure for 24 h. The retained coating, after boiling, is determined.

1072. Significance and Use

~~1072.1~~ The conditions of the practice are designed to identify the adequacy of a slow-setting grade of emulsified asphalt (CSS-D 2397) to properly mix, coat, and adhere to a specified silica sand aggregate.

~~1072.2~~ This practice is intended to confirm the adhesive properties that exist between a cationic emulsion and silica sand and the adequacy of the sample to remain coated after being submerged in boiling water.

1083. Apparatus and Material

~~1083.1~~ *Heat Source*—Hot plate or Bunsen burner. The use of a Bunsen burner will necessitate the placement of an interfacial material between the flame and beaker.

~~1083.2~~ *Screen*—850 μm mesh folded into a circular configuration with the edges folded downward, or cut a strip of 850 μm mesh screen 25.4 mm by 355.6 mm in length and a circular screen of the circumference of 1000-mL beaker. Bend the strip into a circle and insert it in the bottom of the beaker. Place the circular screen on top of the strip.

~~1083.3~~ *Beaker*, 1000-mL.

~~1083.4~~ *Paper Napkin*.

~~1083.5~~ *20–30 Standard Ottawa Silica Sand*, as described in Specification C 778 (silica sand should be washed to remove impurities prior to test).

~~1083.6~~ *Spatula*—A steel spatula or its equivalent, having a blade of approximately 200 mm in length.

~~1083.7~~ *Mixing Container*, 400-mL glass or stainless steel beaker or bowl.

~~1083.8~~ *Beaker Tongs*.

~~1083.9~~ *Eye Protection*—Suitable safety glasses with side shield or any other appropriate eye protection.

~~1083.10~~ *Hand Protection*—Heat resistant gloves.

1094. Procedure

~~1094.1~~ Weigh 150 g of dry silica sand into the mixing container.

1094.2 Add 12 g of the emulsion and immediately begin to mix vigorously for 20 to 60 s or until silica sand is completely coated. (Water may be added to facilitate mixing; 1.0 % is generally sufficient.)

1094.3 The sample should be spread onto a paper napkin in such a manner as to facilitate curing. Allow to air cure for 24 h. (Remove sample from paper napkin and break into several pieces; observe whether sample is completely cured. If sample is not completely cured, allow additional curing time.)

1094.4 Boil about 500 mL of distilled water in a 1000-mL beaker containing 850 μ m mesh screen shelf. Place the coated silica sand in the boiling water on top of the screen.

1094.5 Boil for 10 min and then decant the water.

1094.6 Spread the sample on a level surface and observe the coating of the mix.

1105. Report

1105.1 From the visual examination of the amount of coated and uncoated areas in the mixture, record the retained coating, after boiling, of the total sand surface area. If the coating is in excess of 50 %, the emulsion should be considered as having a passing rating for classification of slow-setting cationic emulsified asphalt.

PRACTICE FOR DETERMINING FIELD COATING OF EMULSIFIED ASPHALTS

~~111.~~

106. Scope

~~1106.1~~ This is a quick field test method to ascertain the compatibility of an asphalt emulsion with the job aggregate.

~~112.~~

107. Summary of Practice

~~11207.1~~ A measured amount of the job aggregate is hand-mixed with a measured amount of the emulsion supplied to the job. The ability of the emulsion to remain as a coating during a 5-min mixing cycle is observed. The resistance offered by the coating to wash-off is determined by repeated filling with water and emptying a container of the coated aggregate.

~~113.~~

108. Significance and Use

~~11308.1~~ The practice is proposed for use at the project site to determine (1) the ability of an asphalt emulsion to coat the job aggregate, (2) the ability of the emulsion to withstand mixing, and (3) the water resistance of the emulsion coated aggregate.

~~114.~~

109. Apparatus

~~114.1~~

~~109.1~~ *Metal Containers*, ½-L capacity (friction-top pint cans).

~~114.2~~

~~109.2~~ *Metal Porcelain Saucepan*, (2½ to 3-L), equipped with a handle.

~~114.3~~

~~109.3~~ *Dispensing Graduate*, 50-mL capacity, preferably plastic.

~~114.4~~

~~109.4~~ *Serving Spoon*, long-handled.

1150. Procedure

1150.1 Derim the ½-L can.

1150.2 Fill the can level with the job aggregate, deleting any sizes above 19 mm.

1150.3 Measure out 50 mL of emulsified asphalt.

1150.4 Dump the aggregate (1150.2) and the emulsion (1150.3) into the porcelain saucepan.

1150.5 Hand mix vigorously for 5 min with the long-handled spoon.

1150.6 Observe (1) whether the stone is fully coated with the emulsion and rate the coating as good, fair or poor—a rating of good means fully coated by the asphalt emulsion exclusive of pinholes and sharp edges of the aggregate, a rating of fair applies to the condition of an excess of coated area over uncoated area, and a rating of poor applies to the condition of an excess of uncoated area over coated area; and (2) the presence, if any, of free water, which denotes breakdown of the emulsion.

1150.7 Refill the ½-L can with the coated stone.

- 1150.8 Set the can of coated stone upright in the porcelain saucepan.
1150.9 Fill the can with water and pour off. Repeat this step five times.
1150.10 Dump the contents of the can onto newspapers. Repeat the observations made in 1150.6 and record.

1161. Report

- 1161.1 Report the observations made in 1150.6 and 1150.10 as the results from this practice.

EMULSIFIED ASPHALT/JOB AGGREGATE COATING PRACTICE

1172. Scope

1172.1 This practice may be used to identify the adequacy of slow setting grade of emulsified asphalt to mix with and coat a dense and fine-graded job aggregate. It is a laboratory practice of screening emulsion candidates for mixing with and coating job aggregates and is not to be construed as a mix design test method.

1183. Summary of Practice

1183.1 A weighed amount of dry job aggregate is hand-mixed with a weighed amount of water for prewetting the aggregate. The wetted aggregate is then hand-mixed with a weighed amount of emulsified asphalt of known asphalt-cement content until maximum coating of the job aggregate is obtained. (Mix time is usually 15 to 120 s.) The adequacy of emulsified asphalt for mixing with job aggregate is determined by using various amounts of water and emulsified asphalt until a maximum coating of the job aggregate is obtained. This coating is rated as good, fair, or poor.

1194. Significance and Use

1194.1 The conditions of the practice are designed to identify the adequacy of emulsified asphalt, slow-setting grade (CSS-D 2397 and SS-D 977) for mixing with and coating dense-graded aggregate and fine-graded aggregate.

~~120.~~

115. Apparatus

~~120.1~~

115.1 *Containers*—A 1000-mL glass beaker, a 1.0-L friction-top metal can, or 1000-mL stainless steel beaker or bowl.

~~120.2~~

115.2 *Mixing Tool*—A steel spatula or its equivalent, having a blade approximately 200 mm in length.

~~120.3~~

115.3 *Balance*, capable of weighing 1000 g to within ± 0.1 g.

1216. Procedure

1216.1 Weigh 300 g of dry job aggregate into the container and add water basis dry weight of aggregate. Immediately begin to mix vigorously for 1 min or until all aggregate surfaces subjectively appear to be wetted (as a guide, 2 to 8 % water for dense-graded aggregate and 4 to 12 % water for fine-graded aggregate). The natural moisture in a job aggregate may be used in the test if predetermined. Additional water may then be added, if necessary, to obtain the desired level of water to be used for prewetting the aggregate.

1216.2 Add the emulsion and immediately begin to mix vigorously, scraping sides and bottom of container, for 15 to 120 s or until maximum coating has been attained (as a guide, basis dry mass of aggregate, 3 to 7 % Asphalt Cement (A/C) residue for dense aggregate and 4 to 8 % A/C residue for fine aggregate). Example: 8 % emulsion at 60 % solids would be equivalent to 4.8 % asphalt cement residue in the mix.

1216.3 If mix appears to be too dry and insufficiently coated repeat 1216.1 and 1216.2, using an increased amount of water or emulsified asphalt, or both. If mix appears to be too wet from excessive water or emulsified asphalt, or both, repeat 1216.1 and 1216.2, using less water or emulsified asphalt, or both.

1216.4 For each job aggregate mix observe and record the amount of aggregate prewetting water and asphalt cement residue from the emulsified asphalt and note the one mix which provides the best aggregate coating.

1216.5 Rate the best coating as good, fair, or poor using the ratings as defined in Section-8†.

~~122.~~ **76.**

117. Report

12217.1 Report the observations made in 1216.2 and 1216.3 relating to amount of aggregate prewetting water and residual asphalt needed for best obtainable aggregate coating.

12217.2 Report the maximum coating achieved as good, fair, or poor in accordance with Section-84 76.

DENSITY OF EMULSIFIED ASPHALT

~~123.~~

118. Scope

12318.1 This test method is used to determine the density of emulsified asphalt used in highway construction. This unit weight is computed by determining the mass of an asphalt emulsion contained in a standard measure of known volume.

~~124.~~

119. Significance and Use

12419.1 This test method provides a controlled laboratory test for the determination of quantitative volumes of emulsion asphalt for use in bills of lading, invoicing, and application rates.

1250. Apparatus

1250.1 *Density Cup*—Stainless steel measure of known standard volume (83.2 mL).

1250.2 *Balance*, accurate to 0.01 g.

1250.3 *Water Bath*, constant-temperature, maintained at 25°C.

1261. Procedure

1261.1 Stir the emulsion sample and place in a constant-temperature water bath maintained at $25 \pm 0.5^\circ\text{C}$ for approximately 1 h.

1261.2 Place the measure and its cap on the balance, tare, and zero the balance.

1261.3 Remove the emulsion sample from the bath and stir, using care to avoid trapping air in the sample. If necessary, strain through a 850- μm sieve to remove any skin or film that might be present in the emulsion.

1261.4 Bring the measure to approximately 25°C and pour the emulsion into the measure, filling it completely.

1261.5 Start placing the cap into the measure and remove, with a clean dry rag or paper, the excess emulsion oozing through the orifice in the cap.

1261.6 When the cap is placed on tightly, clean the measure carefully, weigh on the tared balance to the nearest 0.01 g, and record.

1272. Calculation

1272.1 Calculate the density of the emulsion as follows:

$$W = (G)(11.98) \quad (6)$$

where:

W = unit density of the emulsion, as expressed in g/L, and

G = mass of emulsion in the measure, g.

NOTE 221—If the desired units are to be expressed in pounds per gallon at 25°C, then the calculation would be $W = G/10$. Pounds per gallon at 25°C may be translated to pounds per gallon at 15.6°C by using a multiplier of 1.00475. The calculation of Imperial gallon mass may be made by using the proper conversion factors.

1283. Report

1283.1 Report the unit density of the emulsion in g/L to the nearest whole unit at 25°C.

1294. Precision and Bias

1294.1 The following criteria should be used for judging the acceptability of results (95 % probability):

1294.1.1 Duplicate results by the same operator should not be considered suspect unless they differ by more than the following amount:

Unit Mass Grams per Liter 25°C	Repeatability 0.019
-----------------------------------	------------------------

1294.1.2 The results submitted by each of two laboratories should not be considered suspect unless they differ by more than the following amount:

Unit Mass Grams per Liter 25°C	Reproducibility 0.034
-----------------------------------	--------------------------

~~130.~~

125. Keywords

13025.1 emulsified asphalt; asphalt emulsion; emulsion; cationic emulsion

RESIDUE BY LOW-TEMPERATURE VACUUM DISTILLATION

~~131.~~

126. Scope

13126.1 This test method covers the quantitative determination of residue in asphalt emulsions composed principally of a semisolid or liquid asphaltic base, water, and an emulsifying agent. The emulsion will generally contain polymeric materials. It is especially suitable for asphalt emulsion residue properties that may be altered at the high-temperature 260°C (500°F) distillation.

127. Significance and Use

1327.1 This test method can be used for the quantitative determination of residue in asphalt emulsions at a temperature of 135°C (275°F) with a 60 min distillation test using current distillation apparatus. This test method is suitable for obtaining residues for service evaluation, quality control, and research. This distillation test method is not intended to produce residues equivalent to the D 244 260°C (500°F) distillation procedure.

~~133.~~

128. Apparatus

~~133.1~~

128.1 *Aluminum Alloy Still*, conforming to 13.1, except that a 13-mm (1/2-in.) diameter hole is drilled between the two existing 13-mm (1/2-in.) thermometer holes for the connection of a vacuum gage (see Fig. 10). The joint between the still and lid shall be airtight with the gasket in place. Other heating devices may be used, provided that they use the intended control of temperature during the distillation procedure.

~~133.2~~

128.2 *Connection Apparatus*, conforming to 13.2, with modifications as shown in Fig. 11. The connection tubing may be of suitable materials, provided that the intended vacuum, temperature, and method is maintained. Other forms of condensers may be used, provided that they have an equivalent or greater interior surface area for the condensation of distillate.

NOTE 232—Silicone rubber stoppers are recommended.

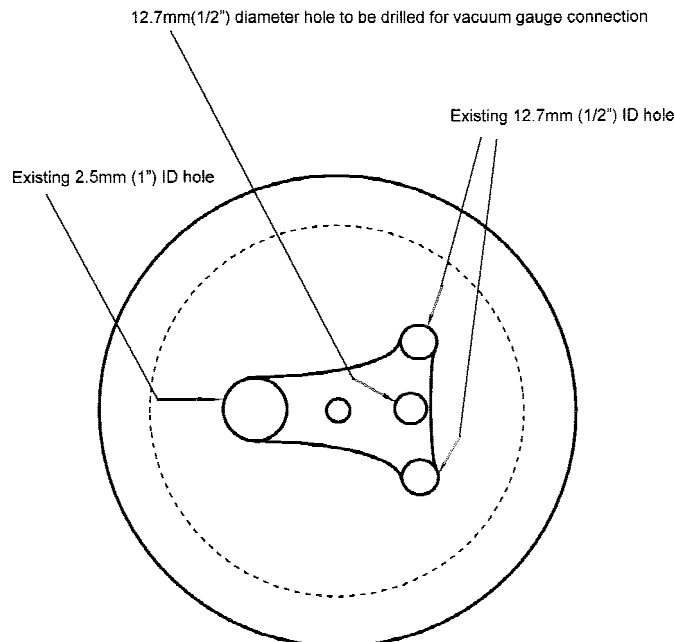

FIG. 10 Aluminum Alloy Still Lid Showing Location of the Hole for Vacuum Gage Connection

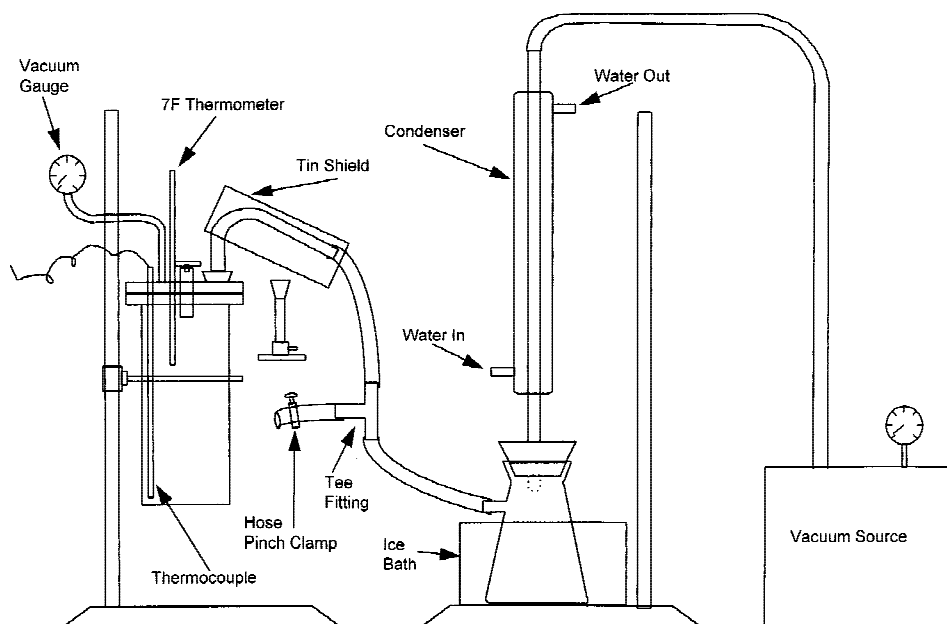

FIG. 11 Connection Apparatus Schematic

133.3-

128.3 *Thermometers*, one ASTM 7F and one thermocouple device¹² calibrated at 135°C (275°F). The thermocouple probe, Type T with exposed junction, should be of sufficient length (approximately 12 in. (305 mm)) to be positioned 6 mm (0.25 in.) off the bottom of the assembled still. The use of other thermometric measuring devices may be acceptable, provided that they have a similar accuracy and response and maintain the intended location in the distillation apparatus.

133.4-

128.4 *Balance*, capable of weighing 3500 g to ±0.1 g.

133.5-

128.5 *Vacuum Pump*, rotary vane type, capable of maintaining a vacuum of 88 kPa below gage pressure or greater.

NOTE 243—Eighty-eight kPa below gage pressure is equal to 26 in. Hg (660 mm) below atmospheric pressure.

133.6-

128.6 *Gasket*, of silicone rubber, 3-mm (1/8-in.) thick, cut to fit the flanged opening on the still. Other gasket materials may be used, provided that they withstand the maximum temperature reached during distillation and are able to maintain the specified vacuum within the still.

133.7-

128.7 *Vacuum Gages*, dial type or other suitable type, connected to vacuum tubing or fittings, or both, to allow attachment to both the vacuum pump and the still apparatus, and capable of reading a minimum vacuum of 88 kPa below gage pressure (660 mm or 26 in. Hg below atmospheric pressure).

133.8-

128.8 *Freezer*, maintained at approximately -10°C.

133.9-

128.9 *Plastic Drink Cups*, disposable, of convenient size and make to serve as a container during freezing of emulsion.

134.-

129. Procedure

13429.1 Weigh 200 to 201 g of a representative sample of the emulsion into the disposable plastic drink cup. Place the cup and sample in the freezer until frozen thoroughly.

NOTE 254—Typically 0.5 g of frozen emulsion is lost in handling the frozen emulsion. If the desired amount of frozen emulsion to be tested is 200.0 g, weigh 200.5 g into the drink cup.

¹² Limestone

¹² Model 8528-10, with Type T probe Model No. G-08522-31, from the Monon Stone Co. of Monon, IN; Cole Parmer Instruments, Niles, IL, has been found suitable as reference aggregate for this purpose.

13429.2 Prepare the still by inserting the thermometer and thermocouple probe through size No. 00 rubber stoppers, and then into the 13-mm (½-in.) holes provided for in the still cover. Adjust the thermocouple so the end is 6 mm (0.25 in.) from the bottom of the still. The bulb of the 7F thermometer should be adjusted to 165 mm (6.5 in.) from the bottom of the still.

13429.3 Prepare the frozen emulsion sample by splitting the edge of the cup and partially peeling the sides away from the sample. Place the frozen sample in the previously weighed still apparatus (including the lid, clamp, thermometer, thermocouple probe, stoppers, and gasket), and weigh to 0.1 g.

13429.4 Assemble the apparatus, and insert the vacuum gage with tubing and stopper attachment into the 13-mm (½-in.) hole located between the thermometer holes. Immediately apply a minimum vacuum of 88 kPa below gage (atmospheric) to the still and contents. Maintain this vacuum throughout the distillation. The elapsed time from removing the sample from the freezer to applying the vacuum should not exceed 2 min.

13429.5 Apply heat from a ring burner or other suitable heating device after 10 min. The ring burner at the beginning of the heating period shall be positioned around the still approximately 200 mm (8 in.) from the bottom of the still. Also apply a small amount of heat to the connecting tube from a Bunsen burner or other suitable heating device. Other heating devices may require a different procedure to apply heat in the intended manner.

NOTE 265—The location of the ring burner or heating device at the start of the test is flexible.

13429.6 As the temperature rises to approximately 149°C (300°F) on the upper thermometer, lower the burner gradually until the thermocouple reads 135 ± 5°C (275 ± 10°F). This should be accomplished in 45 min.

13429.7 Maintain the temperature of the still contents at 135 ± 5°C (275 ± 10°F) for 15 min.

NOTE 276—Cooling of the outside of the still may be done to prevent temperature overshoot. This can be performed by the application of water-soaked toweling applied momentarily to the base of the still with due precaution.

13429.8 At the end of the heating period, reweigh the still apparatus and residue immediately. Record the results.

NOTE 287—The aluminum alloy still at room temperature weighs 0.8 g more than at 135°C (275°F). Correct for this error by adding 0.8 g to the gross weight obtained in 13429.8 before calculating the percentage of residue by distillation.

13429.9 Remove the lid from the still and stir if the residue is sufficiently fluid, and transfer suitable portions of the residue into molds or containers for further testing. If the residue is not sufficiently fluid for pouring without the incorporation of air, heat the sample quickly to the lowest temperature at which this can be achieved. Record the pouring temperature.

1350. Calculation and Report

1350.1 Calculate the residue content as follows:

$$\text{Emulsion residue, \%} = (A \div B) \times 100 \quad (7)$$

where:

A = weight of residue, g, and

B = weight of emulsion, g.

1350.2 Report the following information:

1350.2.1 Sample identification,

1350.2.2 Date of test,

1350.2.3 Pouring temperature,

1350.2.4 Emulsion residue weight percent, and

1350.2.5 Distillation test method.

1361. Precision and Bias

1361.1 *Precision*—The research necessary to report precision has not been conducted.

1361.2 *Bias*—The research necessary to report bias has not been conducted.

1372. Keywords

1372.1 asphalt; asphalt emulsion; distillation; cationic emulsion; emulsified asphalt emulsion; emulsion; low-temperature; vacuum

ASTM International takes no position respecting the validity of any patent rights asserted in connection with any item mentioned in this standard. Users of this standard are expressly advised that determination of the validity of any such patent rights, and the risk of infringement of such rights, are entirely their own responsibility.

This standard is subject to revision at any time by the responsible technical committee and must be reviewed every five years and if not revised, either reapproved or withdrawn. Your comments are invited either for revision of this standard or for additional standards and should be addressed to ASTM International Headquarters. Your comments will receive careful consideration at a meeting of the responsible technical committee, which you may attend. If you feel that your comments have not received a fair hearing you should make your views known to the ASTM Committee on Standards, at the address shown below.



This standard is copyrighted by ASTM International, 100 Barr Harbor Drive, PO Box C700, West Conshohocken, PA 19428-2959, United States. Individual reprints (single or multiple copies) of this standard may be obtained by contacting ASTM at the above address or at 610-832-9585 (phone), 610-832-9555 (fax), or service@astm.org (e-mail); or through the ASTM website (www.astm.org).