



Designation: D 5858 – 96^{ε1}

Standard Guide for Calculating In Situ Equivalent Elastic Moduli of Pavement Materials Using Layered Elastic Theory¹

This standard is issued under the fixed designation D 5858; the number immediately following the designation indicates the year of original adoption or, in the case of revision, the year of last revision. A number in parentheses indicates the year of last reappraisal. A superscript epsilon (ε) indicates an editorial change since the last revision or reappraisal.

^{ε1} NOTE—Paragraph 1.5 was added editorially October 1998.

1. Scope

1.1 This guide covers the concepts for calculating the in situ equivalent layer elastic moduli can be used for pavement evaluation, rehabilitation and overlay design. The resulting equivalent elastic moduli calculated from the deflection data are method-dependent and represent the stiffnesses of the layers under a specific nondestructive deflection testing (NDT) device at that particular test load and frequency, temperature, and other environmental and site-specific conditions. Adjustments for design load, reference temperature, and other design-related factors are not covered in this guide. The intent of this guide is not to recommend one specific method, but to outline the general approach for estimating the in situ elastic moduli of pavement layers.

1.2 This guide is applicable to flexible pavements and in some cases, rigid pavements (that is, interior slab loading), but is restricted to the use of layered elastic theory² as the analysis method. It should be noted that the various available layered elastic computer modeling techniques use different assumptions and algorithms and that results may vary significantly. Other analysis procedures, such as finite element modeling, may be used, but modifications to the procedure are required.

NOTE 1—If other analysis methods are desired, the report listed in Footnote 3 can provide some guidance.

1.3 The values stated in inch-pound units are to be regarded as the standard. The SI units given in parentheses are for information only.

1.4 *This standard does not purport to address all of the safety concerns, if any, associated with its use. It is the responsibility of the user of this standard to establish appropriate safety and health practices and determine the applica-*

*bility of regulatory limitations prior to use.*³

1.5 *This guide offers an organized collection of information or a series of options and does not recommend a specific course of action. This document cannot replace education or experience and should be used in conjunction with professional judgment. Not all aspects of this guide may be applicable in all circumstances. This ASTM standard is not intended to represent or replace the standard of care by which the adequacy of a given professional service must be judged, nor should this document be applied without consideration of a project's many unique aspects. The word "Standard" in the title of this document means only that the document has been approved through the ASTM consensus process.*

2. Referenced Documents

2.1 ASTM Standards:

- D 653 Terminology Relating to Soil, Rock, and Contained Fluids⁴
- D 4123 Test Method for Indirect Tensile Test for Resilient Modulus of Bituminous Mixtures⁵
- D 4602 Guide for Nondestructive Testing of Pavements Using Cyclic-Loading Dynamic Deflection Equipment⁴
- D 4694 Test Method for Deflections with a Falling-Weight-Type Impulse Load Device⁵
- D 4695 Guide for General Pavement Deflection Measurements⁵

3. Terminology

3.1 *Definitions*—In addition to Terminology D 653, the following definitions are specific to this standard:

3.1.1 *backcalculation*—analytical technique used to determine the equivalent elastic moduli of pavement layers corresponding to the measured load and deflections. The analysis

¹ This guide is under the jurisdiction of ASTM Committee D04 on Road and Paving Materials and is the direct responsibility of Subcommittee D04.39 on Non Destructive Testing of Pavement Structures.

Current edition approved Feb. 10, 1996. Published May 1996.

² The concepts of elastic layer theory are discussed in Chapter 2 of *Principles of Pavement Design*, by E. J. Yoder and M. W. Witzczak, published by John Wiley and Sons, Inc., 1975.

³ Corrections or adjustments and a complete discussion of the use of each of these analysis methods with different NDT devices may be found in: Lytton, R. L., F. P. Germann, Y. J. Chou, and S. M. Stoffels "Determining Asphalt Concrete Pavement Structural Properties by Nondestructive Testing," *NCHRP Report No. 327*, National Cooperative Highway Research Program, 1990.

⁴ *Annual Book of ASTM Standards*, Vol 04.08.

⁵ *Annual Book of ASTM Standards*, Vol 04.03.

may be performed by any of the following methods: iteration, database-searching, closed-form solutions (currently available only for two layer pavement systems), and simultaneous equations (using non-linear regression equations developed from layered elastic analysis output data). The primary emphasis of this guide will be concerned with the first method; however, many of the ideas pertaining to the use of the iterative concept also apply to the other approaches. An iterative analysis procedure involves assuming "seed" moduli values for a layered pavement structure, computing the surface deflection at several radial distances from the load, comparing the computed and measured deflections, and repeating the process, changing the layer moduli each time, until the difference between the calculated and measured deflections are within selected tolerance(s) or the maximum number of iterations has been reached. Alternatively, the analysis procedure may involve searching through a data base of precalculated deflection basins computed from a factorial of known layer moduli and thicknesses until a basin is found that "closely matches" the measured deflection basin. When analyzing pavement behavior, surface deflections and other responses are typically calculated (in the "forward" direction) from layered pavement analysis programs that use layer moduli as input. In "backcalculation", *layer moduli* are selected and adjusted to ultimately compute surface deflections that best match known surface deflections.

3.1.2 *deflection sensor*—the term that shall be used in this guide to refer to the electronic device(s) capable of measuring the vertical movement of the pavement and mounted in such a manner as to minimize angular rotation with respect to its measuring plane at the expected movement. Sensors may be of several types, such as seismometers, velocity transducers, or accelerometers.

3.1.3 *deflection basin*—the idealized shape of the deformed pavement surface due to a cyclic or impact load as depicted from the peak measurements of five or more deflection sensors.

3.1.4 *equivalent elastic modulus*—the effective in situ modulus of a material, which characterizes the relationship of stress to strain, specific to the conditions that existed at the time of NDT testing, that is determined by backcalculation procedures for an assigned layer of known or assumed thickness. The collection of all of these layer moduli will produce, within reasonable limits, the same surface deflections as measured at various distances from the center of the load when entered into an layered elastic pavement simulation model analogous to that used in backcalculation.

3.1.5 *pavement materials*—the physical constituents that are contained in all of the various layers of the pavement system; these layers consist of various thicknesses of placed or stabilized in-place materials for supporting traffic as well as the native subgrade or embankment material being protected.

3.1.6 *resilient modulus of elasticity* (M_r)—a laboratory test measurement of the behavior of a material sample (either an intact core or a recompacted specimen) used to approximate the in situ response. Specifically as shown below, the applied cyclic deviator stress divided by the recoverable axial strain that occurs when a confined or unconfined and axially loaded cylindrical material specimen is loaded and unloaded. The

resilient modulus is a function of load duration, load frequency, and number of cycles:

$$M_r = \sigma_d / e_r \quad (1)$$

where:

σ_d = the applied deviator stress, and

e_r = the recoverable (resilient) axial strain.

4. Summary of Guide

4.1 A necessary requirement of most overlay or rehabilitation design procedures is some measure of the in situ or "effective" structural value of the existing pavement. For years, center-of-load (or maximum) deflection measurements have been used to determine the overall structural effectiveness of the existing pavement to carry load repetitions. The analysis of individual surface deflection values and the deflection shape or "basin" represents a technique that can be used to determine separate estimates of the effective layer properties that collectively describe the overall structural capacity of the pavement system.

4.2 A pavement deflection basin can be induced by a static or dynamic surface load. Some pavement materials are viscoelastic, meaning they exhibit elastic behavior at high rates of loading while viscous flow becomes more significant at very slow rates of loading. For this reason, layered elastic theory is appropriate for dynamic loading; however, it is difficult to verify whether these magnitudes of deflection equate to those measured under static loading. When dynamic loadings are applied, the resulting displacements registered at each of the deflection sensors are also dynamic; however, these peak amplitude values do not all occur at the same time. In a static analysis, such as layered elastic theory, these peak dynamic deflections are analyzed as if they are equivalent in magnitude to the deflections that would occur if a load of "equal" magnitude had been applied statically.

4.3 Layered elastic theory is one of the more common analysis methods being used in the design of flexible pavements and, to a lesser degree, rigid pavements. This guide is primarily concerned with the use of layered elastic theory to calculate the layer moduli in flexible pavements. Various computer programs that use some type of deflection-matching iterative procedure or database searching technique have been developed to estimate the pavement material moduli.⁶ This guide discusses the various elements of procedures for calculating and reporting in situ layer moduli of the pavement cross-section that could then be used in rehabilitation and overlay design calculations.

4.4 Presently, there are two distinct categories of analysis methods that may be applied to flexible pavements: quasi-static and dynamic. The quasi-static elastic approaches referred to in this guide, include the Boussinesq-Odemark transformed section methods, the numerical integration layered subroutines,

⁶ The following is a list of some of the backcalculation computer programs that have been developed: MODULUS, ELMOD, ISSEM4, MODCOMP, FPEDD1, EVERCALC, WESDEF, and BOUSDEF. One of the procedures, WESDEF, is available through the U.S. Army Corps of Engineers Waterways Experiment Station. See VanCauwelaert, Alexander, Barker, and White, "A Competent Multilayer Solution and Backcalculation Procedure for Personal Computers," *ASTM STP 1026*, November 1989.

and the finite element methods. As a general principle, the selection of a method for analyzing NDT data to determine layer moduli should be compatible with the analysis procedure that will eventually be used for designing the flexible pavement rehabilitation. That is, if a particular layered elastic computer program is to be used in analyzing the pavements for rehabilitation design purposes, the same computer program (or its equivalent) should be used as the basis for determining the material properties from nondestructive testing of pavements. Similarly, if a finite element procedure is to be used as a basis for design, it also should be used for analyzing NDT pavement data. In summary, it is important to consistently use the same analysis method in both backcalculation and design applications.

4.5 The fundamental approach employed in most iterative backcalculation analysis methods estimating the in situ layer moduli is that the solution initiates at the outer deflection sensor location(s) to determine the moduli of the lowest subgrade layer above the apparent stiff layer, that usually has an assigned modulus (see Fig. 1). The calculation sequence progresses toward the center of the basin using the “known” lower layer moduli and the deflections at smaller radial offsets to calculate the moduli of the higher layers. This sequence is repeated in an iterative cycle until a solution is obtained that nearly matches the calculated and measured deflections. When using the database-searching or Boussinesq-Odemark transformed section methods, the sequence may not be the same. In all approaches, layer thicknesses and Poisson’s ratios must either be known or assumed. Although the principles of these approaches are applicable to all pavement types (flexible and rigid), some analysis methods are more appropriate for specific pavement types and specific NDT devices.³ Also, some pavement analysis models are restricted to pavement structures where the strength of layers decreases with depth (for example, cement-aggregate mixtures could not be modeled below a granular base material).

5. Significance and Use

5.1 This guide is intended to present the elements of an approach for estimating layer moduli from deflection measurements that may then be used for pavement evaluation or overlay design. To characterize the materials in the layers of a pavement structure, one fundamental input parameter measured in the laboratory and used by some overlay design procedures is the resilient modulus. Deflection analysis pro-

vides a technique that may be used to estimate the in situ equivalent layer elastic moduli of a pavement structure as opposed to measuring the resilient moduli in the laboratory of small and sometimes disturbed samples. For many overlay design procedures that are based on layered elastic theory, the resilient modulus is approximated by this equivalent layer elastic modulus, because the equivalent modulus is determined as an average value for the total layer at the in-situ stress conditions of an actual pavement.

5.2 It should be emphasized that layer moduli calculated with this procedure are for a specific loading condition and for the environmental conditions at the time of testing. For these moduli to be used in pavement evaluations and overlay design, adjustments to a reference temperature, season, and design load may be required. These adjustments are not a part of this guide.

5.3 The underlying assumption used in the solution is that a representative set of layer moduli exists for the particular loading condition (magnitude and area) and temperature condition, such that the theoretical or calculated deflection basin (using quasi-static layered elastic theory and the assumed static load characteristics of the NDT device) closely approximates the measured deflection basin. In reality, depending on the tolerance allowed in the procedure and the relative number of layers compared to the number of deflection sensors, several combinations of moduli may cause the two basins to “match” (or be within tolerance) reasonably well. A certain degree of engineering judgement is necessary to evaluate these alternative solutions and select the most applicable combination or eliminate unreasonable solutions, or both.

5.4 There have been several studies that compared the results of various types of equipment and analysis methods; unfortunately, considerable variability has been noted. At this time, no precision estimate has been obtained from a statistically-designed series of tests with different “known” materials and layer thicknesses. The backcalculated results do vary significantly with the various assumptions used in analysis to emulate the actual condition as well as with the techniques used to produce and measure the deflections. Since the guide deals with a computerized analytical method, the repeatability is excellent if the input data and parameters remain the same. The bias of the procedure can not be established at this time. The identity of the “true” in situ modulus, based on resilient modulus testing or some other field or laboratory test, needs to be standardized before the bias of the method can be established.

6. Analytical Approach

6.1 There are several mathematical techniques based on layered elastic theory that may be used to analyze deflection measurements for determining effective layer moduli in a pavement structure.

NOTE 2—The user is cautioned against using layer moduli that have been determined from one analysis model in a different model for designing the rehabilitation, because of inherent differences between models. As a general rule, the same model used in overlay or pavement rehabilitation design should also be used in the backcalculation of layer moduli, as discussed in 4.4, unless correlations are developed and verified.

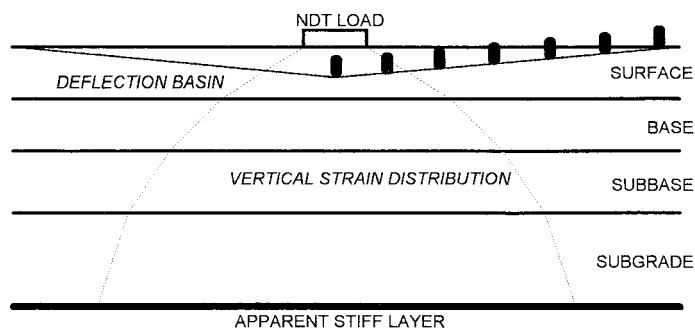

FIG. 1 Depiction of NDT Load Stress Distributed Through Pavement

6.2 Regression equations or simplified algorithms developed from quasi-static layered elastic model computer-generated output may be used, provided the resulting equivalent layer elastic moduli are used to recalculate, in the layered elastic model, the deflections at each point used within the measured deflection basin. The percent error (between calculated and measured deflection basins) should then meet the requirements in 7.3.4.

7. Procedure

7.1 The following discussion provides general guidelines intended to assist in the estimation of the structural layer moduli of existing pavements.

7.1.1 *Deflection Testing*—Guide D 4602 and Test Method D 4694 provide procedures that can be used for nondestructive deflection testing of pavements using dynamic cyclic and impulse (impact) loading deflection equipment, respectively. These test procedures generally refer to the calibration and operation of various types of NDT equipment. It should be emphasized that proper calibration of the sensors is essential for measuring accurate pavement responses, especially those far away from the load. The location and spacing of measurements are recommended in Guide D 4695.

7.1.2 *Delineating Pavement Sections*—Plots of deflection parameters as a function of longitudinal distance or station can be very helpful in defining pavement subsections with similar characteristics. Longitudinal profile graphs of both maximum surface deflection and the deflection measurement furthest from the load should be prepared for the pavement being evaluated. If the applied load inducing these deflections varied by more than five percent, the individual deflections (especially the maximum) should be normalized to a reference load magnitude to lessen the scatter in the data:

$$\text{normalized deflection} = \frac{\text{actual deflection} \times (\text{reference load/actual load})}{\text{reference load/actual load}} \quad (2)$$

Other deflection basin parameters, such as AREA, may also be plotted to provide an indication of the variation in overall load distribution capacity of the pavement. However, the above normalization process is not necessary or appropriate for the AREA calculation. A general formula for AREA is defined as follows for more than one deflection sensor (other definitions exist for specific numbers of sensors, such as Fig. 2⁷; results from different equations may not be comparable):

$$\text{AREA} = (\text{Dist}_2/2) + \left[\sum_{i=2}^{n-1} d_i \times (\text{Dist}_i + \text{Dist}_{i+1}) / (2 d_{\max}) \right] + [\text{Dist}_n \times d_n / (2 d_{\max})] \quad (3)$$

⁷ Hoffman, Mario S., and Thompson, Marshall R., "Backcalculating Nonlinear Resilient Moduli from Deflection Data," *Transportation Research Record* 852, pp. 42–51.

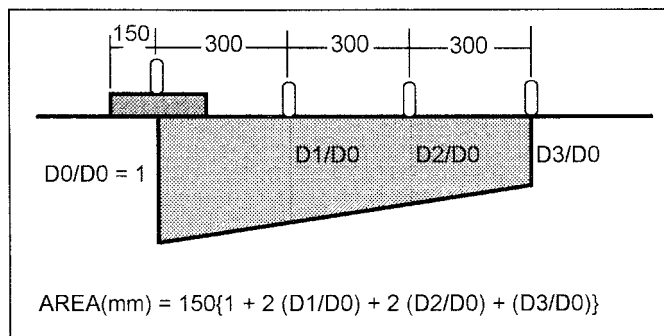

FIG. 2 Concept of "Area" for Structural Capacity

where:

- n = the number of sensors used to measure basin,
- d_i = the deflection measured with Sensor i ,
- Dist_2 = the distance between Sensor 2 and 1,
- Dist_n = the distance between Sensor n and $n-1$,
- Dist_i = the distance between Sensor i and $i-1$,
- Dist_{i+1} = the distance between Sensor i and $i+1$, and
- d_{\max} = the maximum deflection at the center of the load, measured with Sensor 1.

By evaluating these and other longitudinal profiles, pavement segments with significantly different pavement response characteristics can be visually or statistically designated, or both, as individual subsections.

NOTE 3—For some overlay design procedures, results from deflection testing are initially used to designate design sections and aid in evaluating differences in material properties. Deflection data are plotted in the form of a profile by location throughout the length of the pavement section and then separated into subsections with similar deflection basin characteristics. In other procedures, layer moduli are initially calculated for each measured basin and then these moduli or the expected pavement performance based on these moduli are used to delineate uniform subsections.

NOTE 4—Subsections with similar deflections, deflection basin characteristics, moduli, expected pavement performance, or any combination of these, can be statistically checked by using the Student-t test to determine if two sets of data are significantly different.

7.1.2.1 Under variable topographical or geological conditions, backcalculation of layer moduli for each measurement location may be preferred or even necessary. In more uniform situations, for simplification purposes, an actual "representative" deflection basin could be selected for analysis. However, some site-specific information can be missed or additional error introduced, or both. Basins with large differences (greater than two standard deviations within the design section) that may occur could be overlooked by analyzing only a "representative" basin. Locations with notably different deflection magnitudes should be evaluated individually.

NOTE 5—If the pavement exhibits only occasional cracks, such as asphalt thermal cracking or concrete joints or cracks, the deflection basins selected for analysis should represent uncracked surfaces (or measurements should be taken with the load and all sensors at least 5 ft (1.5 m) from any cracks), because layered elastic theory does not consider these discontinuities. If the pavement surface has extensive cracking, then these areas should be evaluated as well and the type and severity of cracks should be noted on the report with the backcalculated layer elastic moduli. These kinds of notations may be helpful in explaining the analysis findings for that location. The calculated equivalent moduli will usually reflect the surface condition.

7.2 Approximate material classifications and layer thicknesses can be obtained from historical as-built construction records. A pavement coring program will provide more accurate thicknesses, preferably to the nearest 0.2 in. (5 mm) for bound layers or 1.0 in. (25 mm) for unbound layers, and the material type of each layer in the pavement structure, and also check for the existence of a shallow rigid layer (for example, bedrock).

NOTE 6—As a general rule, all material types and layer thicknesses recovered from as-built construction plans should be verified using field cores or borings, or both, if at all possible. The number of cores required per analysis section or project is not a part of this guide. Engineering judgement may be needed or statistical methods may be utilized⁸ to determine the number of cores required to estimate layer thicknesses to a desired level of precision and degree of confidence. Thickness variations are dependent on construction practice and maintenance activities. However, it should be noted that any deviation between the assumed and actual in-place layer thicknesses may affect the backcalculated layer moduli significantly.

7.3 For each individual measured or the “representative” measured deflection basin to be evaluated, the required data are entered into the selected analytical technique. The NDT device loading characteristics, Poisson’s ratios and thicknesses of all the assumed individual layers, deflection values and locations, and possibly initial estimates of the layer moduli (seed moduli) are included in the input data set. The Poisson’s ratio of the subgrade should be selected carefully. Small variations in this value may cause significant differences in the moduli of the upper pavement layers. Typical ranges of Poisson’s ratio values, that may be used if other values are not available, are the following:

asphalt concrete:	0.30 to 0.40
portland cement concrete:	0.10 to 0.20
unbound granular bases:	0.20 to 0.40*
cohesive soil:	0.25 to 0.45*
cement-stabilized soil:	0.10 to 0.30
lime-stabilized soil:	0.10 to 0.30

* Depending on stress/strain level and degree of saturation.

NOTE 7—In programs where seed moduli are required, their selection can affect the number of necessary iterations, the time required before an acceptable solution is achieved and, possibly, the final moduli that are determined. If an extremely poor selection of a seed modulus is made, the analysis may possibly fail to find a solution within the specified tolerance between calculated and measured deflections (7.3.4). In this case, an alternate set of seed moduli may provide an acceptable solution before reaching the maximum allowable number of iterations. Ordinarily, if the tolerance is sufficiently narrow, the final moduli that are calculated are not significantly affected by the values chosen for the initial set of seed moduli. The following typical values of seed moduli may be used, if other values are not available:

asphalt concrete:	500 000 psi (3500 MPa)
portland cement concrete:	5 000 000 psi (35 000 MPa)
cement-treated bases:	600 000 psi (4100 MPa)
unbound granular bases:	30 000 psi (200 MPa)
unbound granular subbases:	15 000 psi (100 MPa)
cohesive soil:	7000 psi (50 MPa)
cement-stabilized soil:	50 000 psi (350 MPa)
lime-stabilized soil:	20 000 psi (140 MPa)

In addition, many programs require a range of acceptable

⁸ The statistical techniques dealing with material variability and sampling procedures are discussed in Chapter 13 of *Principles of Pavement Design*, written by E. J. Yoder and M. W. Witzczak, published by John Wiley and Sons, Inc., 1975.

moduli values for each of the layers to improve the speed of operation and to limit the moduli to their approximate practical values.

7.3.1 *Thin Layers in Pavements*—For upper surface layers that are thin, that is, less than one-fourth of the diameter of the loaded area (for example, 3 in. (75 mm) or less for a 12-in. ((300 mm) loading plate) or layers that are thinner than the layer directly above, the elastic moduli often cannot be accurately determined by most backcalculation methods. These thin layers, if possible, should be combined in assigned thickness with a similar type of material above or below the thin layer, or the moduli of the thin layers can be estimated and assigned as “known” values. For thin asphalt concrete layers (with very few cracks) on unbound granular base courses, the elastic moduli may be measured in the laboratory using Test Method D 4123 or mathematically estimated using available regression equations⁹ or nomographs.¹⁰ The temperature at which the modulus is measured or estimated should correspond to that which existed in the field at the time the deflections were measured. For flexible pavements with single or double bituminous surface treatments, the surface layer is usually combined with the base material in the backcalculation procedure.

7.3.2 *Number of Layers*—Based on recommended practice, the number of unknown layers (including subgrade but excluding any fixed apparent stiff layer) to be backcalculated should be no more than five and preferably less. In order to solve for a number of “unknowns” (for example, four layer moduli), as a minimum, that same number and more, if available, of “knowns” (for example, five deflections) should be provided, to better define the basin and reduce the number of possible combinations of moduli that would provide a deflection basin match. Although more deflection points can be derived artificially by interpolating between actual measured points, this is not recommended because additional error can be introduced by not interpreting the correct changes in slope between points. Therefore, if four deflection sensors were used, then a maximum of four unknown layers (three pavement layers and the subgrade) could be used in the structural evaluation. For a pavement where more than three to five layers were constructed, the thicknesses of layers of similar (same type of binder) materials may be combined into one effective structural layer for backcalculation purposes. These analysis techniques, in general, iteratively progress toward the center of the deflection basin from the outer edge of the basin in determining these layer moduli. For example, it is possible to estimate¹¹ the minimum distance from the center of the applied load at which the deflection measured at the pavement surface is due primarily to the strain or deflection of the subgrade (see Fig. 1), relatively independent of the overlying layers. Therefore, a

⁹ The regression equation on page 16 of *Research Report No. 82-2*, “Research and Development of The Asphalt Institute’s Thickness Design Manual (MS-1) Ninth Edition,” provides a method of calculating modulus as a function of mix parameters.

¹⁰ A nomographic solution for estimating asphalt concrete stiffness as a function of mix and asphalt properties is detailed in Appendix 2 of the *Shell Pavement Design Manual*, Shell International Petroleum Company Ltd, 1978.

¹¹ Chapter III of *AASHTO Guide for Design of Pavement Structures 1986*, published by the American Association of State Highway and Transportation Officials, contains a procedure for deriving the effective radius of the subgrade stress zone.

 **D 5858**

measured deflection beyond this distance can be used to solve for the effective subgrade modulus at that stress level directly. For stress-dependent materials, it is advisable that the first sensor beyond this distance be used to solve for the subgrade modulus. Depending on the materials in the pavement structure, it may be necessary to employ non-linear response parameters in the process. Each succeeding deflection point can be attributed to strains that occur in response to the load in successively more layers and it therefore provides some additional “known” information about the “higher” pavement layers. The effective moduli of these higher layers are then estimated using the closer (to the load) deflections and the previously estimated lower layer moduli.

7.3.3 Estimation of an Apparent Stiff Layer—Many back-calculation procedures include an apparent stiff ($M_r = 100\,000$ to $1\,000\,000$ psi (700 to 7000 MPa)) layer at some depth into the subgrade. It is intended to simulate either bedrock or the depth where it appears that vertical deflection is negligible. Research has shown that the results of the analysis can be significantly inaccurate by not including such a layer or by not locating this stiff layer near the actual depth, particularly if the actual depth is less than 20 ft (6 m). The magnitude of this error is also affected by the modeling of the subgrade; for example, a nonlinear stress-dependent (softening) material would also lead to “stiffer” subgrade layers with depth, or decreasing stress, if included in the total number of layers.

7.3.4 Tolerances of Deflection Matching—The accuracy of the final backcalculated moduli is affected by the tolerance allowed within the procedure for determining a match between the calculated and measured deflections. Two different approaches are commonly employed for evaluating this “match”. These are an arithmetic absolute sum (AASE) of percent error and a root mean square (RMSE) percent error. In both procedures, the engineer should bear in mind that the significance of random sensor error can be much greater at the outer sensor locations where the actual measured deflections are very small; therefore, different tolerance weighting factors for each sensor may be a consideration.

7.3.4.1 An arithmetic absolute sum of percent error, AASE, may be used to evaluate the match between the calculated and measured deflection basins and is defined as:

$$AASE = 100 \sum_{i=1}^n |(dmeas_i - dcalc_i)/dmeas_i| \quad (4)$$

where:

- n = number of sensors used to measure basin,
- $dmeas_i$ = measured deflection at point i , and
- $dcalc_i$ = calculated deflection at point i .

The magnitude of tolerance varies with the number of deflection sensors used to define the basin. It is suggested that the sum of percent error should not be greater than the following values for the pavement section to be adequately characterized:

- 9 to 18 % if nine deflection sensors are used,
- 7 to 14 % if seven deflection sensors are used, and
- 5 to 10 % if five deflection sensors are used.

No less than five deflection sensors should be used to describe the basin.

7.3.4.2 A root mean square percent error, RMSE, may also

be used to evaluate the match between the calculated and measured deflection basins. This measure of error is less dependent on the number of sensors used to characterize the deflection basin. However, the same minimal number of deflection sensors (five) as above should be followed. RMSE is defined as follows:

$$RMSE = 100 \left\{ 1/n \sum_{i=1}^n [(dcalc_i - dmeas_i)/dmeas_i]^2 \right\}^{0.5} \quad (5)$$

where the parameters are the same as previously defined. A maximum tolerance limit of 1 to 2 % on the root mean square error is recommended.

NOTE 8—If the above requirements for the percent error cannot be met, then conditions may exist which violate the assumptions of layered elastic theory, or the actual layer compositions or thicknesses may be significantly different than those used in the model. Additional field material sampling or coring at these locations may provide the means to resolve this problem. If this condition cannot be reconciled, then more complex models which can simulate dynamic loading, material inhomogeneities, or physical discontinuities in the pavement should be used.

NOTE 9—There are several factors that affect the accuracy and applicability of backcalculated layer moduli. Any analysis method that uses an iterative or searching procedure to match measured to calculated deflection basins will result in some error. The magnitude of this error depends on different factors, some of which include: combining different layers into one structural layer, number of deflection points and limitation on number of layers used in the analysis, “noise” or inaccuracies contained in the sensor measurement itself; small deflections that are close in magnitude to the established random error for the sensors, discontinuities such as cracks in the pavement, particularly if located between the load and the sensor, inaccurate assumption of the existence and depth of an apparent stiff layer; depths less than 5 ft (1.524 m) may require a dynamic analysis, differences between assumed and actual layer thicknesses. Due to inaccurate or unavailable measurements or point-to-point variability, saturated clays directly beneath base materials, extremely weak soils beneath the base and overlying much stiffer soils, non-uniform load pressure distributions at the load-pavement contact area, non-linear, inhomogeneous, or anisotropic materials in the pavement structure (especially the subgrade) and for successive layers, a stiffness ratio (M_r upper layer/ M_r lower layer) less than 0.5.

8. Report

8.1 Include the following in the report documenting the backcalculated layer moduli results for each pavement section:

8.1.1 Identification/location of pavement tested, location of test points analyzed, date and time of deflection testing, file name of original data file, and the backcalculation program (including version number) used.

8.1.2 Details of the NDT device (load range, load footprint, and spacing of all deflection sensors).

8.1.3 The thicknesses, Poisson’s ratios (assumed or measured) and material types of each layer in the pavement structure throughout the test section as well as the source of this information. Any differences in construction history or pavement cross-section within the section should be noted if the information is known or available. In addition, any layers that were combined into one structural layer for analysis should be so indicated.

8.1.4 Visual Characteristics of the Test Section—These could include notations on the location of changes in pavement features such as surface appearance or type, transitions from cut to fill, presence of culverts, different soil types, and



different shoulder widths. In addition, the locations, types, severity, and extent of pavement distresses such as rutting, washboarding, block cracking, and fatigue cracking should be noted to aid the engineer in understanding any anomalies in the data. The location of the applied loading relative to any nearby surface distress should also be noted.

8.1.5 The ambient air temperature and pavement surface temperature for each basin measurement. In addition, the average asphalt pavement layer temperature can be obtained by drilling a small hole to the mid-depth of the asphalt concrete, filling with liquid (for example, oil or water), and measuring the liquid temperature with a thermometer set in the fluid after the reading has stabilized. If this is not possible, some procedures also exist for estimating the pavement temperature as a function of depth using the air temperatures of the previous five days and the current pavement surface temperature.^{12,13}

¹² Southgate, Herbert F., and Deen, Robert C., "Temperature Distribution within Asphalt Pavements and Its Relationship to Pavement Deflection," *HRB Record 291*, 1969, pp. 116–131. Research performed by the Kentucky Department of Highways produced a method for estimating the temperature of asphalt concrete pavements at varying depths.

8.1.6 The measured load magnitude and measured and calculated deflections for each basin used to backcalculate layer moduli. When a "representative" deflection basin is used, report the range of the actual values measured for each sensor.

8.1.7 The equivalent layer elastic moduli of each structural layer for each backcalculated basin along with the mean and standard deviation for the design section of each layer. In some cases, the results are too few or are not normally-distributed, and other statistical tools may be more appropriate, such as median values, outlier analyses, and frequency distribution plots.

8.1.8 For each layer moduli calculation, the arithmetic absolute sum of percent error or the root mean square percent error between the measured and calculated deflection basins.

9. Keywords

9.1 backcalculation; deflection basin; layered elastic theory; NDT (nondestructive deflection testing); pavement moduli

¹³ Stubstad, R. N., Baltzer, S., Lukanen, E. O., and Ertman-Larsen, H. J., "Prediction of AC Mat Temperatures for Routine Load/Deflection Measurements," *Proceedings of the Fourth International Conference on the Bearing Capacity of Roads and Airfields*, Minneapolis, Minnesota, July 1994, pp. 401–412.

The American Society for Testing and Materials takes no position respecting the validity of any patent rights asserted in connection with any item mentioned in this standard. Users of this standard are expressly advised that determination of the validity of any such patent rights, and the risk of infringement of such rights, are entirely their own responsibility.

This standard is subject to revision at any time by the responsible technical committee and must be reviewed every five years and if not revised, either reapproved or withdrawn. Your comments are invited either for revision of this standard or for additional standards and should be addressed to ASTM Headquarters. Your comments will receive careful consideration at a meeting of the responsible technical committee, which you may attend. If you feel that your comments have not received a fair hearing you should make your views known to the ASTM Committee on Standards, at the address shown below.

This standard is copyrighted by ASTM, 100 Barr Harbor Drive, PO Box C700, West Conshohocken, PA 19428-2959, United States. Individual reprints (single or multiple copies) of this standard may be obtained by contacting ASTM at the above address or at 610-832-9585 (phone), 610-832-9555 (fax), or service@astm.org (e-mail); or through the ASTM website (www.astm.org).