



Designation: D 5635 – 034

Standard Test Method for Dynamic Puncture Resistance of Roofing Membrane Specimens¹

This standard is issued under the fixed designation D 5635; the number immediately following the designation indicates the year of original adoption or, in the case of revision, the year of last revision. A number in parentheses indicates the year of last reapproval. A superscript epsilon (ϵ) indicates an editorial change since the last revision or reapproval.

1. Scope

1.1 This test method covers the evaluation of the maximum dynamic puncture load that roofing membrane samples can withstand, without allowing the passage of water, when subjected to impact from a rigid object having a sharp edge.

1.2 This laboratory test can be conducted at any desired temperature using membrane samples manufactured in a factory or prepared in a laboratory.

1.3 Roof membrane specimens to which the test method is applicable include bituminous built-up, polymer-modified bitumens, vulcanized rubbers, non-vulcanized polymeric, and thermoplastic materials.

1.4 This test method is not applicable to aggregate-surfaced membrane specimens; however, it is applicable to specimens having factory-applied granules.

1.5 The values stated in SI units are to be regarded as the standard. The values given in parentheses are for information only.

1.6 *This standard does not purport to address all of the safety concerns, if any, associated with its use. It is the responsibility of the user of this standard to establish appropriate safety and health practices and determine the applicability of regulatory limitations prior to use.*

¹ This test method is under the jurisdiction of ASTM Committee D08 on Roofing and Waterproofing and is the direct responsibility of Subcommittee D08.20 on Roofing Membrane Systems.

Current edition approved Oct. 1, 2003⁴. Published November 2003. Originally approved in 1994. Last previous edition approved in 1998² as D 5635 – 98³.

2. Referenced Documents

2.1 *ASTM Standards:*²

C 578 Specification for Rigid, Cellular Polystyrene Thermal Insulation

D 1079 Terminology Relating to Roofing, Waterproofing, and Bituminous Materials

3. Terminology

3.1 *Definitions:*

3.1.1 For definitions of terms used in this test method, refer to Terminology D 1079.

4. Summary of Test Method

4.1 The roofing membrane test specimen, set on a thermal insulation substrate, is subjected to a predetermined dynamic impact load created by a rigid falling puncture head. The head falls through a quarter-circle trajectory from a vertical position to horizontal position under gravitational acceleration.

4.2 The puncture energy is increased from 5 to 50 J (119 to 1190 ft-pdl) in 2.5 J (59.4 ft-pdl) increments until puncture of the membrane specimen occurs or until the maximum energy is reached.

4.3 Puncture of the test specimen is assessed by visual examination and verified by conducting a watertightness test.

5. Principle of the Test Method

5.1 The energy at impact is equated to the potential energy of the raised puncture head as follows:

$$E = mgH \quad (1)$$

where:

m = mass of the puncture head (in kg or lbm),

g = gravitational acceleration (in m/s^2 or ft/s^2), and

H = height through which the puncture head falls (in metres or feet).

In this test method, the height is fixed at 0.51 m (1.67 ft). With gravitational acceleration being equal to $9.8 m/s^2$ ($32 ft/s^2$), the impact energy is, thus, equal to the following:

$$E = 5 \cdot m \quad (2)$$

where:

m = kg.

or

$$E = 53.4 \cdot m \quad (3)$$

where:

m = lbm.

Increasing the mass of the puncture head from 1 to 10 kg (2.2 to 22 lbm) in increments of 0.5 kg (1.1 lbm) increases the puncture energy from 5 to 50 J (119 to 1190 ft-pdl) in increments of 2.5 J (59.4 ft-pdl).

NOTE 1—A counter weight placed on the falling arm opposite to the axis of rotation eliminates the need to include the mass of the arm in the determination of the impact energy.

6. Significance and Use

6.1 An important factor affecting the performance of membrane roofing systems is their ability to resist dynamic puncture loads. This test method provides a means to assess dynamic puncture resistance.

6.2 This test method can be used to compare the dynamic puncture resistance of a single type of membrane as a function of a variety of insulation substrates or, conversely, to compare the resistance of a number of membrane specimens set on a single type of insulation.

6.3 The effect of temperature on puncture resistance can be studied by conducting the test under controlled conditions using such equipment as an environmental chamber, oven, or freezer.

6.4 The test method can be useful in developing performance criteria for membrane roofing systems.

6.5 The test method can be useful in developing classifications of dynamic puncture resistance of membrane roofing systems.

6.6 While it is considered that the results obtained by this laboratory test can afford a measure of the dynamic puncture resistance of membrane roofing systems in the field, (provided that service loads and temperature conditions are known) no direct correlation has yet been established.

² For referenced ASTM standards, visit the ASTM website, www.astm.org, or contact ASTM Customer Service at service@astm.org. For *Annual Book of ASTM Standards*, Vol 04.06, volume information, refer to the standard's Document Summary page on the ASTM website.

7. Apparatus

7.1 *Dynamic Puncture Device*—The dynamic puncture device consists primarily of a heavy base, a falling arm, and puncture head (see Fig. 1).

7.1.1 The falling arm is attached to the base so that it can rotate freely (for example, using ball bearings) from a vertical to horizontal position. The length of the arm is sufficiently long so that the puncture head can be secured to it at a distance that is 0.51 m (1.67 ft), $\pm 0.5\%$, from the point of rotation at the base.

7.1.2 The shape and dimensions of a typical puncture head are given in Fig. 2. When mounted on the arm, the face of the puncture head is parallel to axis of rotation. Several heads of different mass may be needed. Alternatively, a means for adding weights to a given puncture head to increase its mass can be used. The head and additional weights shall constitute a continuous series of mass from 1 to 10 kg (2.2 to 22 lbm) in 0.5 kg (1.1 lbm) increments. The mass of the puncture head shall be within $\pm 0.5\%$ of that selected.

NOTE 2—It is suggested that the puncture head be fabricated from 1018 mild steel to minimize risk of damage during its use. No matter the metal from which the puncture head is made, users of the test device should periodically examine the puncture head to check that damage has not occurred during use.

7.1.3 A counter weight, equivalent to the mass of the falling arm, is placed on the arm on the side of the axis of rotation opposite to that holding the puncture head. The presence of the counter weight eliminates the need to include the mass of the arm in the determination of the puncture energy. Alternatively, if a counter weight is not used, then the mass of the arm shall be included in the determination of the impact energy.

7.1.4 The device shall incorporate a mechanism that allows the puncture head to be kept stationary in an upright position, forming an angle from the vertical not exceeding 5° . This mechanism shall allow release of the arm so that it falls freely without any additional motion imposed.

NOTE 3—A vacuum release mechanism has been found suitable for this purpose.

7.1.5 The base of the device, supporting the arm and puncture head, is placed on a horizontal surface that is sufficiently stable. This surface will shall not shake, vibrate, or otherwise move when the test is conducted at maximum impact energy. The arm and puncture head of the dynamic puncture device shall be horizontal when the puncture head contacts the horizontal surface of the test specimen (see Fig. 1). Heavy rigid shims having length and width dimensions larger than those of the test specimen and substrate may be used.

7.2 *Specimen Frame*—A frame, having minimum exterior and interior dimensions of 250 by 250 mm (9.8 by 9.8 in.) and 200 by 200 mm (7.9 by 7.9 in.), respectively, and a minimum mass of 2.5 kg (5.5 lbm) is used to hold the test specimen in place on the insulation substrate during the test. Adhere medium abrasive, 60 grit sand paper to the bottom surface of the specimen frame.

NOTE 4—The bottom surface of the frame is that surface which sets on the specimen. The use of sand paper assists in securing the specimen during test. Double-side adhesive tape has been found suitable for adhering the sand paper to metal frames. The sand paper is replaced with new pieces when it no longer assists in securing the specimen during test.

8. Sampling and Sample Preparation

8.1 *Single-Ply Samples*—Cut the test specimens directly from the sheet membrane material in accordance with 9.1.

8.2 *Multi-Ply Samples Prepared in the Laboratory:*

8.2.1 Condition all components at $23 \pm 2^\circ\text{C}$ ($74 \pm 3^\circ\text{F}$) and $50 \pm 5\%$ relative humidity for 24 ± 0.25 h prior to constructing the membrane sample.

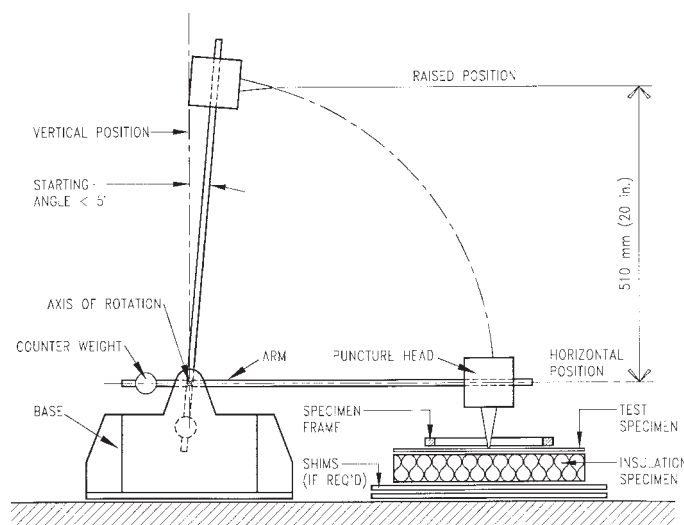
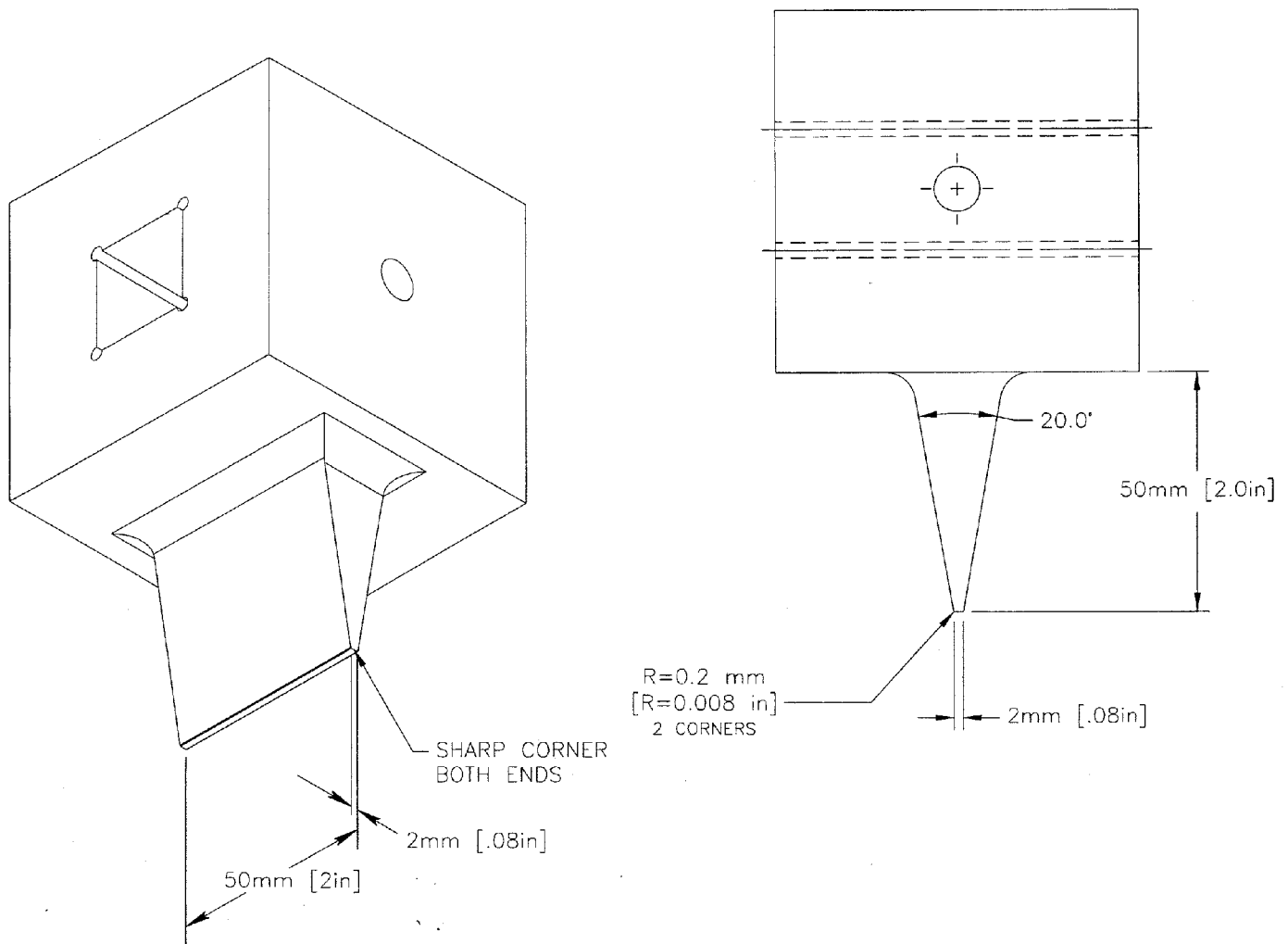

FIG. 1 Schematic of the Dynamic Puncture Device



NOTE 1—Dimensions are in millimetres.
FIG. 2 Shape and Dimensions of Puncture Head

8.2.2 Prepare the multi-ply membrane samples at least 0.90 by 1.20 m (3 by 4 ft) in accordance with the membrane manufacturer's instructions or by using other preparation methods at the discretion of the test laboratory. The method of preparation shall be described in the report of the test. The quantity of material in each layer of the membrane sample shall be within 10 % of that specified, and the entire sample shall be within 5 %. Cut the test specimens directly from this larger membrane sample, in accordance with 9.1.

9. Test Specimens

9.1 *Dimensions*—The dimensions of the membrane test specimens and insulation substrates are 250 by 250 mm (9.8 by 9.8 in.). Cut the test specimens and substrates to size using a metal template having these dimensions.

9.2 *Number of Specimens*—The number of specimens can vary depending upon the actual performance of the membrane material found during testing. It is suggested that at least twelve specimens be available at the beginning of the test.

9.3 *Type of Membrane Specimen Substrate*—The use of any roof insulation as a membrane specimen substrate is allowable. The membrane substrate shall be expanded polystyrene board conforming to Specification C 578, Type IX and having a thickness of 38 mm (1.5 in.), $\pm 15\%$, unless otherwise specified. Whatever insulation is used, the sections used as the specimen substrate throughout the test shall be taken from the same manufactured lot.

10. Conditioning and Test Temperature Selection

10.1 Condition the apparatus and all specimens at the selected test temperature $\pm 2^\circ\text{C}$ ($\pm 3^\circ\text{F}$) for a minimum of 8 h prior to testing.

10.2 It is not prohibited to conduct tests across a range of cold, room, and elevated temperatures. Unless otherwise specified, the test shall be conducted at 23°C (74°F).

10.2.1 The selected temperature shall be maintained at $\pm 2^\circ\text{C}$ ($\pm 3^\circ\text{F}$) throughout the test.

11. Procedure

11.1 Screening Procedure:

11.1.1 Secure the membrane specimen on the insulation using the specimen frame.

11.1.2 Position the assembly under the falling arm of the dynamic puncture device so that the puncture head is set on the center of the surface of the specimen. Align the arm and puncture head horizontally to the specimen surface. The direction of the test specimen (that is, longitudinal or transverse) shall be perpendicular to the direction of the puncture head.

11.1.3 Select an initial mass of the puncture head, in integral increments of 0.5 kg (1.1 lbm), somewhat below that at which the specimen may be expected to fail.

NOTE 5—Pretesting specimens at various masses is useful to estimate the initial load to be applied.

11.1.4 Raise the arm and puncture head to the vertical position and allow it to fall freely onto the specimen surface. Then visually examine the specimen to determine whether puncture has occurred.

11.1.5 If it cannot be determined visually that the specimen has or has not punctured, apply a suitable watertightness test. One example of a suitable test is the use of water pressure of 5000 Pa (0.73 lbf/in.²) applied for 15 min to the surface of the membrane specimen that was subjected to the impact (Note 6). Another example is a dielectric test (Note 7). If the test specimen is not watertight, repeat the procedure in 11.1.4 and 11.1.5 on another test specimen using a puncture head having lesser mass.

NOTE 6—One type of watertightness test that has been used to examine whether membrane specimens have been punctured incorporates a water column sealed to the top of the membrane specimen. A water height of 500 mm (20 in.) provides a pressure of 5000 Pa (0.73 lbf/in.²). A similar type of watertightness test uses a chamber in which the membrane specimen is sealed and into which water is forced at the specified pressure.

NOTE 7—One dielectric test for examining whether membrane specimens have been punctured uses a 15 kV dielectric tester with a pointed electrode. The test specimen is placed on a metal plate (second electrode), such that contact exists between the impacted area of the specimen and the metal plate. The size of the metal plate is at least that of the specimen. A 15 kV charge is applied across the specimen at the location of the applied puncture force by passing the pointed electrode over the impacted area while in contact with the specimen surface. If sparks are observed, puncture has occurred.

11.1.6 Using the same specimen, repeat 11.1.4 and 11.1.5 as necessary, increasing the puncture head mass by 0.5 kg (1.1 lbm) each time, until puncture occurs or until the maximum puncture head mass of 10 kg (22 lbm) is reached. Shift the specimen and insulation substrate at least 25 mm (1 in.) so that the puncture head impacts an area that was not previously struck.

11.1.7 Using a new membrane specimen and a new insulation substrate, repeat the test at the last mass selected to verify the results of the screening procedure.

11.2 Dynamic Puncture Resistance Determination:

11.2.1 Conduct the test on three new membrane specimens and insulation substrates in accordance with 11.1, using a puncture head mass that is 0.5 kg (1.1 lbm) less than that which caused puncture in the screening procedure or at the 10 kg (22 lbm) maximum mass that did not result in puncture. Consider the results as follows:

11.2.1.1 If none of the three specimens are punctured at this selected mass, repeat the test, using three new specimens at incrementally higher puncture head masses, the number of times necessary until at least one of the three specimens fail, or until the maximum mass of the test is reached. Calculate the greatest energy at which none of a set of three specimens failed using Eq 2 (or 2B). Report that energy as the puncture resistance of the test specimens.

11.2.1.2 If two of the original three specimens are not punctured, test an additional specimen at the same puncture head mass. If this additional specimen is not punctured, calculate the energy using Eq 2 (or 2B) and report that energy as the puncture resistance of the test specimens. If the additional specimen is punctured, repeat the test the number of times necessary using three new specimens and a puncture head mass that is incrementally reduced by 0.5 kg (1.1 lbm). Report the puncture resistance for the greatest impact energy that did not produce puncture.

11.2.1.3 If two of the original three specimens are punctured, repeat the test, as necessary, using three new specimens and a puncture head mass that is incrementally reduced by 0.5 kg (1.1 lbm). Report the puncture resistance for the greatest impact energy that did not produce puncture.

11.2.1.4 To verify that puncture did not occur, use a watertightness test on the three specimens (see 11.1.5) for which the puncture resistance is reported.

12. Report

12.1 Report the following information:

12.1.1 Complete identification of the roof membrane sample including type, source, manufacturer, and method of preparation if made in the laboratory.

12.1.2 Complete identification of the insulation substrate including type, source, manufacturer, density, and thickness.

12.1.3 The temperature of the test.

12.1.4 A description of the watertightness test used.

12.1.5 The dynamic puncture resistance of the membrane material as the maximum impact energy that three specimens sustained without puncture and loss of watertightness. The direction of the specimen shall be included.

13. Precision and Bias

13.1 At the present time, there is no basis for statements concerning the precision and bias of test results obtained from either within-laboratory or between-laboratory testing.

14. Keywords

14.1 dynamic puncture; impact energy; insulation substrate; membranes; puncture; roofing; test method

ASTM International takes no position respecting the validity of any patent rights asserted in connection with any item mentioned in this standard. Users of this standard are expressly advised that determination of the validity of any such patent rights, and the risk of infringement of such rights, are entirely their own responsibility.

This standard is subject to revision at any time by the responsible technical committee and must be reviewed every five years and if not revised, either reapproved or withdrawn. Your comments are invited either for revision of this standard or for additional standards and should be addressed to ASTM International Headquarters. Your comments will receive careful consideration at a meeting of the responsible technical committee, which you may attend. If you feel that your comments have not received a fair hearing you should make your views known to the ASTM Committee on Standards, at the address shown below.

This standard is copyrighted by ASTM International, 100 Barr Harbor Drive, PO Box C700, West Conshohocken, PA 19428-2959, United States. Individual reprints (single or multiple copies) of this standard may be obtained by contacting ASTM at the above address or at 610-832-9585 (phone), 610-832-9555 (fax), or service@astm.org (e-mail); or through the ASTM website (www.astm.org).