



Designation: C 520 – 98

Standard Test Methods for Density of Granular Loose Fill Insulations¹

This standard is issued under the fixed designation C 520; the number immediately following the designation indicates the year of original adoption or, in the case of revision, the year of last revision. A number in parentheses indicates the year of last reapproval. A superscript epsilon (ϵ) indicates an editorial change since the last revision or reapproval.

1. Scope

1.1 These test methods are applicable to granular loose fill insulation materials such as vermiculite and perlite. They may be used for other insulation materials with similar flow and settling properties.

1.2 *Method A* will be used to determine bulk density.

1.3 *Method B* will be used to determine design density and, with Method A, can be used to calculate percent loss of volume due to settling.

1.4 *This standard does not purport to address all of the safety concerns, if any, associated with its use. It is the responsibility of the user of this standard to establish appropriate safety and health practices and determine the applicability of regulatory limitations prior to use.*

2. Referenced Documents

2.1 *ASTM Standards:*

C 168 Terminology Relating to Thermal Insulating Materials²

C 390 Criteria for Sampling and Acceptance of Preformed Thermal Insulation Lots²

3. Terminology

3.1 The definitions of terms used in this method shall be in accordance with Terminology C 168.

3.2 *Definitions of Terms Specific to This Standard:*

3.2.1 *bulk density*—the apparent density of the granular material, according to the procedures in Method A, as received, and including the normal voids incorporated during the placement procedure. No conditioning is required unless specified.

3.2.2 *design density*—the apparent density of the granular material, according to the procedures in Method B, as conditioned, and including the normal voids incorporated during the placement and subsequent procedures.

3.2.3 *percent volume loss*—the loss in volume between the as received bulk density and the design density determined by

induced settling procedures or specified conditioning, or both, expressed as a percent.

4. Significance and Use

4.1 *Method A* will be used primarily as a manufacturing quality control and field test method without the need for conditioning. For more accurate research purposes, conditioning may be specified.

4.2 *Method B* will be used, when specified, to determine the density at which other insulation properties such as thermal resistance and placement coverage will be determined.

5. Apparatus

5.1 *Bulk Density Measure*—A lightweight rigid box having a volume of 1 ft³ (0.03 m³). All inside dimensions shall be 12.00 ± 0.04 in. (305 ± 1 mm).

5.2 *Scale(s)*—A scale or balance with an accuracy of at least 1 % of the sample weight. More than one type may be required for Method B.

5.3 *Design Density Sample Measure*—The sample container (see Fig. 1) shall be made of construction grade plywood and two 48-in. (1220 mm) long, nominal 2 by 8-in. wood joists. The joists shall be spaced 16 in. (406 mm) apart from center to center. The inside width and depth of the container will depend somewhat on the actual dimensions of the 2 by 8-in. lumber used and should result in an interior volume of approximately 2.9 ± 0.1 ft³ (0.082 ± 0.003 m³). The actual volume must be measured.

5.4 *Screed*—A suitable piece of wood, metal, or plastic at least 20 in. (508 mm) long with a thin straight edge suitable for leveling the loose, granular material.

5.5 *Tapping Hammer and Frame*—This shall include a standard 7½-lb (3.4 kg) sledge hammer. The total length of the handle shall be approximately 34 in. (864 mm). A ¼-in. (6-mm) hole is drilled through the handle to provide a pivot point 32⅛ in. (816 mm) from the center line of the head of the hammer. It shall be incorporated in a moveable frame as described in Fig. 1.

5.6 *Blowing Machine, Optional*—The blowing machine, if used, shall be typical of the type of blowing machine recommended by the insulation manufacturer and shall be equipped

¹ These test methods are under the jurisdiction of ASTM Committee C-16 on Thermal Insulation and are the direct responsibility of Subcommittee C 16.32 on Mechanical Properties.

Current edition approved Aug. 10, 1998. Published October 1998. Originally published as C 520 – 63 T. Last previous edition C 520 – 91.

² *Annual Book of ASTM Standards*, Vol 04.06.

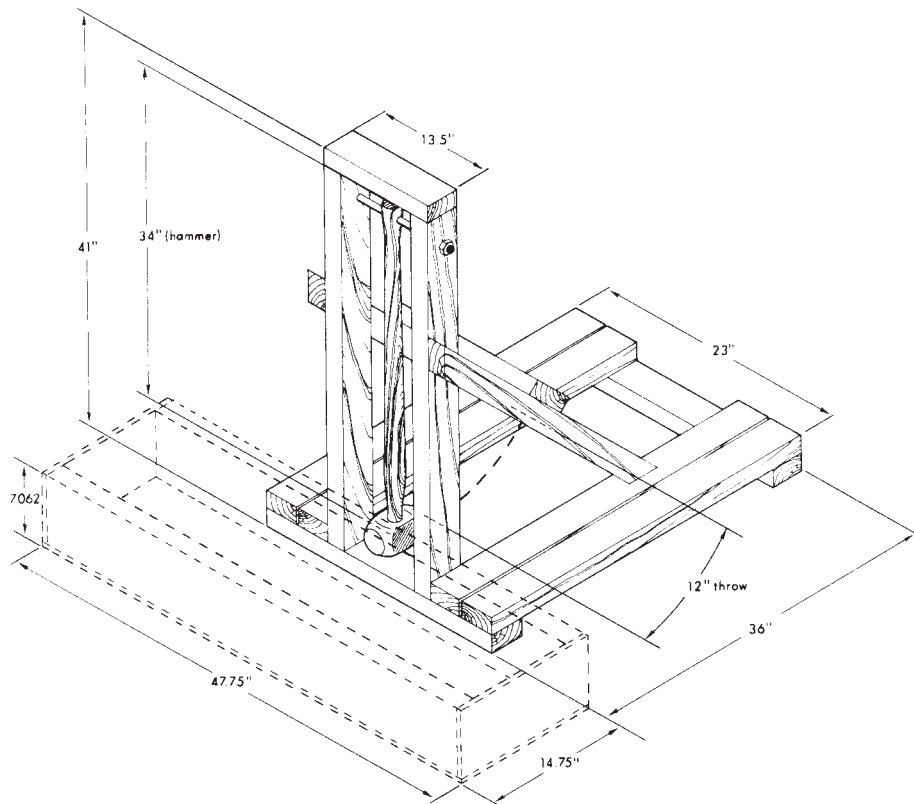

FIG. 1 Sample Container

with 100 ft (30 m) of the type and diameter of blower hose recommended by the insulation manufacturer for field installation.

6. Sampling

6.1 For the purposes of standard tests, sampling shall be in accordance with Criteria C390.

7. Conditioning

7.1 When specified as a requirement of testing, condition samples for at least 24 h at $50 \pm 2\%$ relative humidity and $73 \pm 2^\circ\text{F}$ ($23 \pm 1.1^\circ\text{C}$), and test under the specified conditions.

8. Procedure

8.1 Method A:

8.1.1 Remove approximately one cubic foot of insulation to be tested from the shipping container in such a way to provide a representative distribution of particle size and weight.

8.1.2 Fill the bulk density sample container described in 5.1 to overflowing with a shovel or scoop, discharging the insulation from a height not to exceed 2 in. (51 mm) above the top of the container. Take care to prevent, so far as possible, segregation of the particle sizes of which the sample is composed. Level off the surface of the insulation in such a way that any slight projections of the larger pieces of the coarse insulation shall approximately balance the larger voids in the surface below the top of the container. Take care not to compact the sample.

8.1.3 Determine the net weight of the insulation by subtracting the weight of the empty container from the weight of the full container.

8.1.4 Using fresh material, repeat the test for a total of three times.

8.1.5 *Calculation*—Calculate bulk density as follows:

$$\text{Bulk density (B)} = \frac{W}{V} \quad (1)$$

where:

W = net weight, lb (kg), and

V = volume of container, ft^3 (m^3).

8.2 Method B:

8.2.1 Weigh test bags of insulation.

8.2.2 Place the sample container on a flat surface. Pour the material into the container from a height not less than 6 in. (152 mm) nor more than 24 in. (610 mm) above the top of the container in a natural motion and speed normal to that used in the field. Use the screed to level off the material to the top of the container, being careful not to compress or compact the insulation.

8.2.3 Place the sample frame and tapping hammer against the side of the measure, and draw the face of the hammer back 12 in. from the side of the container. Allow the hammer to pivot freely into the side of the measure one time from each side (repositioning the frame each time if required).

8.2.4 Refill the measure by adding additional insulation and screeding level with the top of the container.

8.2.5 Reweigh the test bag of insulation to determine total material added to the container. Record the total weight added and the volume of the container.

8.2.6 Using fresh material, repeat the test for a minimum of three measurements.

8.2.7 Calculations:

8.2.7.1 Calculate the design density as follows:

$$\text{Design density (D)} = \frac{W}{M} \quad (2)$$

where:

W = final net weight, lb (kg), and

V = volume of container, ft³ (m³).

8.2.7.2 Calculate the volume loss as follows:

$$\text{Volume loss (\%)} = \frac{D - B}{B} \times 100 \quad (3)$$

9. Report

9.1 Report the following information:

9.1.1 Report the density in pounds per cubic foot (kilograms per cubic meter) for each test and the average of the three or more tests for each method.

9.1.2 If required, report the percent volume loss on placement for each sample and the average of the three or more tests.

10. Precision and Bias

10.1 Granular loose fill insulations, as a class, generally require care in handling during testing due to friability, varying particle size, and a tendency to pack, settle, or segregate as a result of rough handling or vibration.

10.2 The precision of Test Method A with regard to a single unit of product, can be stated only in terms of a single operation, single measurement, and single sample. At the 95 % confidence limit, the standard deviation for vermiculite is ± 0.25 lb/ft³, for perlite ± 0.30 lb/ft³.

10.3 The precision of Test Method B is expressed as the precision of the single operator, multi-sample, and single measurement of design density. At the 95 % confidence limit, the standard deviation for vermiculite is ± 0.12 , for perlite ± 0.20 lb/ft³.

11. Keywords

11.1 bulk density; density; design density; granular loose fill; insulation; perlite; thermal insulation; vermiculite; volume loss

The American Society for Testing and Materials takes no position respecting the validity of any patent rights asserted in connection with any item mentioned in this standard. Users of this standard are expressly advised that determination of the validity of any such patent rights, and the risk of infringement of such rights, are entirely their own responsibility.

This standard is subject to revision at any time by the responsible technical committee and must be reviewed every five years and if not revised, either reapproved or withdrawn. Your comments are invited either for revision of this standard or for additional standards and should be addressed to ASTM Headquarters. Your comments will receive careful consideration at a meeting of the responsible technical committee, which you may attend. If you feel that your comments have not received a fair hearing you should make your views known to the ASTM Committee on Standards, 100 Barr Harbor Drive, West Conshohocken, PA 19428.