



Designation: E 1289 – 97

## Standard Specification for Reference Specimen for Sound Transmission Loss<sup>1</sup>

This standard is issued under the fixed designation E 1289; the number immediately following the designation indicates the year of original adoption or, in the case of revision, the year of last revision. A number in parentheses indicates the year of last reapproval. A superscript epsilon ( $\epsilon$ ) indicates an editorial change since the last revision or reapproval.

### 1. Scope

1.1 This specification describes the construction and installation of a standard reference specimen for quality control of laboratory sound transmission loss measurements using Test Method E 90. Test Method E 90 allows a significant latitude in the construction and operation of a test facility. It is the objective of standard measurement procedures that the property of a reference specimen being measured have the same value in all facilities.

1.2 This specification addresses the need for a reference specimen for sound transmission loss facilities where measurements are made according to Test Method E 90. It describes in detail how the specimen is to be constructed and installed in a test opening.

1.3 The values stated in SI units are to be regarded as standard. The values in parentheses are provided for information only.

### 2. Referenced Documents

#### 2.1 ASTM Standards:

- C 634 Terminology Relating to Environmental Acoustics<sup>2</sup>
- E 90 Test Method for Laboratory Measurement of Airborne-Sound Transmission Loss of Building Partitions<sup>2</sup>

### 3. Terminology

3.1 *Definitions*—For definitions of terms used in this specification, see Terminology C 634.

### 4. Construction of Reference Specimen

#### 4.1 General:

4.1.1 The reference specimen is composed of framed steel panels. The required materials for fabrication and installation are as follows:

- Galvanized steel sheets—width, 1200 mm (4 ft); thickness, 0.62 mm (0.024 in. or 24 gauge). Check weight for compliance with limits given in 4.2.1.
- Steel right angles with 25-mm (1-in.) flanges—thickness, 3.2 mm (0.125 in.).
- Blind rivets—diameter, 3 mm (0.125 in.).
- Duct tape, 50 mm (2 in.) wide.
- Drywall screws, Type W—length, 31.8 mm (1.25 in.).

- Bolts (10–24 by 1 in.)—25 mm long with appropriate nuts and washers.
- Fasteners, to hold wood frame to the perimeter of the test opening.
- Caulking, non-hardening.
- Wood framing, approximately 40 mm by 90 mm (2 by 4 in. nominal) in width and thickness.

NOTE 1—The quantity and length of each component needed depends on the size of the laboratory test opening.

4.1.2 The weight of each component of the reference specimen and the assembled specimen shall be measured and kept on record. In addition, the thickness of each of the steel panels shall be measured in six locations. (See Appendix X1.)

#### 4.2 Assembly:

4.2.1 *Sheets*—The 1200-mm (4-ft nominal)-wide rectangular galvanized sheets shall be 24 gauge, 0.62 mm (0.024 in.) thick. The weight of the sheets shall be  $5.1 \pm 0.7 \text{ kg/m}^2$  ( $1.05 \pm 0.15 \text{ lb/ft}^2$ ). The length of each sheet shall be a few millimeters less than the height of the laboratory test opening. The total width of all the sheets shall be a few millimeters less than the width of the test opening. This may require that one sheet be cut lengthwise. The intent is that when installed, the panels fill the test opening completely.

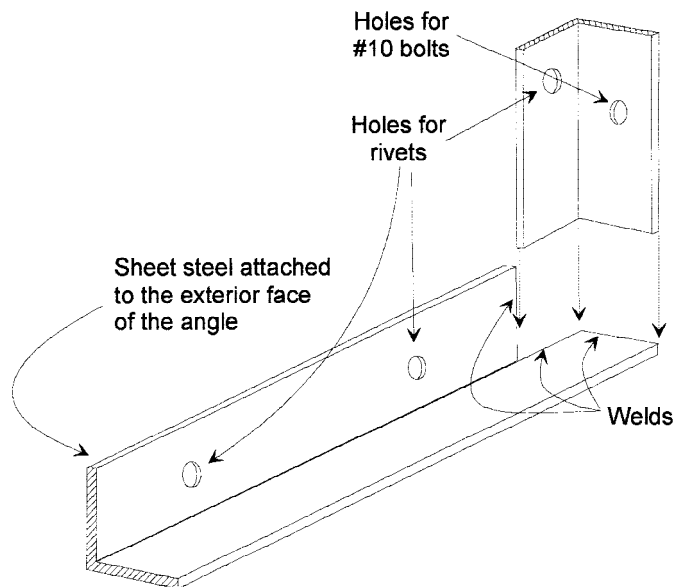

FIG. 1 Notching and Welding Corners of Steel Angles

<sup>1</sup> This specification is under the jurisdiction of ASTM Committee E-33 on Environmental Acoustics and is the direct responsibility of Subcommittee E33.03 on Sound Transmission.

Current edition approved Nov. 10, 1997. Published July 1998. Originally published as E 1289 – 89. Last previous edition E 1289 – 91.

<sup>2</sup> *Annual Book of ASTM Standards*, Vol 04.06.

4.2.2 *Frame*—Cut steel right angles to size to form a frame

for each sheet; the frame shall have the same outside dimensions as the sheets. Notch and weld the steel angles to form the four corners of the frame as shown in Fig. 1. Alternatively, miter the angles and weld similarly. Smooth corners after welding.

4.2.3 *Panels*—Construct a panel by riveting steel sheets to the frames.

4.2.3.1 Drill holes at 100 mm (4 in.) on-center around the perimeter of the sheets for the installation of the blind rivets. To assure proper alignment of the sheets with the frame, it is recommended to drill a few holes and then install rivets to hold the sheet in place. Once this is done, the remaining holes may be drilled and the rivets installed. Position these holes to avoid conflict with the clearance holes described in 4.2.3.2.

4.2.3.2 Drill 4 mm (0.16 in.) diameter holes through horizontal members of the frame and sheet as shown in Figs. 2 and 3. These are clearance holes for the drywall screws used to

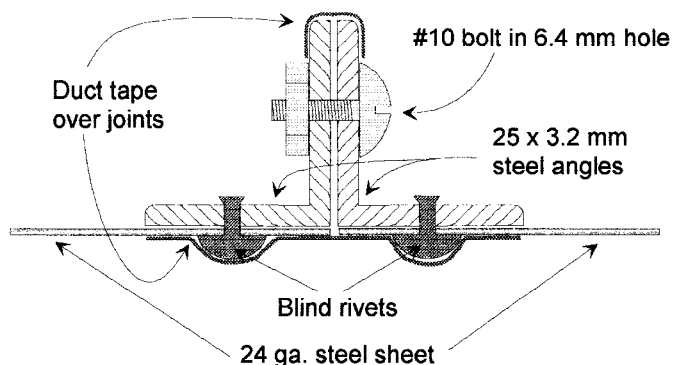

**FIG. 3 Construction Details of Steel Panels (not to scale)**

perimeter of the laboratory opening. Use a double bead of caulking between the wood frame and the surface of the laboratory opening. Use suitable fasteners no more than 300 mm (11.8 in.) on-center.

5.2 Place the reference specimen against the wood frame with the flanges of the panel frames as shown in Fig. 4.

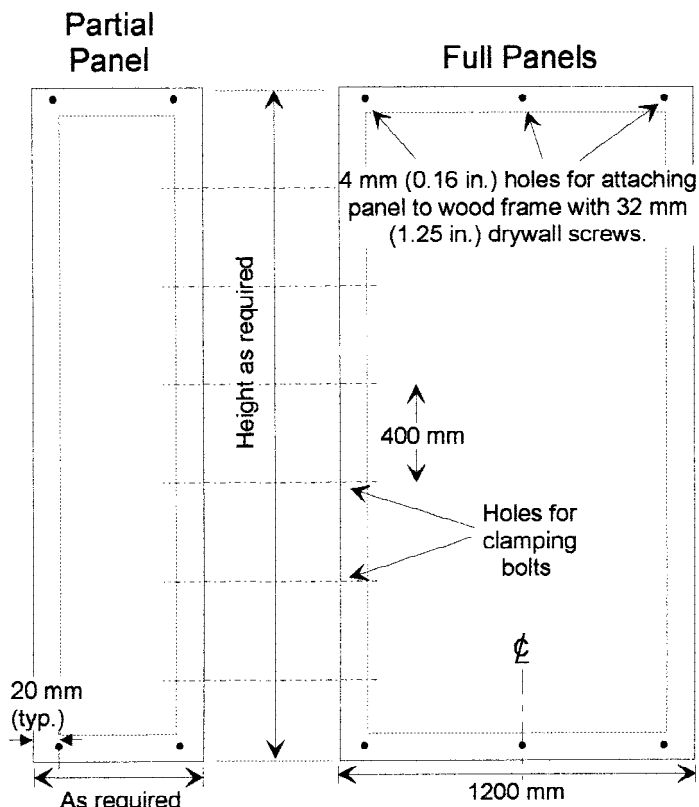

**FIG. 2 Construction Details of Steel Panels (not to scale)**

attach the panel to the wood plate (see 5.5).

4.2.3.3 Drill 6.4 mm (0.25 in.) diameter holes at 400 mm (16 in.) on-center through the vertical flanges of the steel frame. These are clearance holes for the bolts used to connect the panels together (see 5.4). The holes in adjacent vertical members should be carefully aligned with each other to ease installation of the panels.

**5. Installation**

5.1 Using approximately 40 mm by 90 mm wood studs (nominal 2 in. by 4 in.), install a wood frame around the

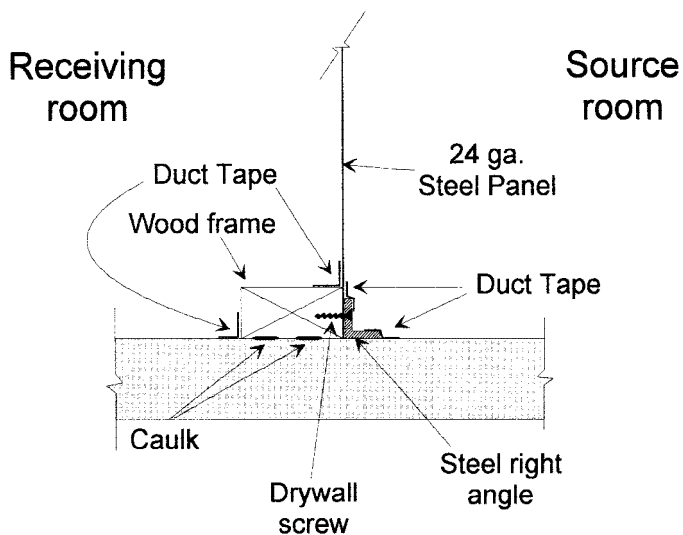

NOTE 1—Wood frame caulked, specimen joints and perimeter taped on both sides.

**FIG. 4 Installation of Reference Specimen Showing Caulking of Wood Frame and the Taping of the Specimen Joints and Perimeter on Both Sides**

5.3 Insert 25-mm (1-in.) long No. 10-24 bolts or equivalent through the holes in adjacent vertical flanges drilled according to 4.2.3.3. Washers may be used if desired. Tighten nut snugly to close the gap between adjacent panels.

5.4 Fasten the test panels to the wood frame with Type W drywall screws 31.8-mm (1.25-in.) long inserted through the holes drilled according to 4.2.3.2.

5.5 Seal the test panel joints on both sides with a single layer of 50-mm (2-in.) wide duct tape (centered on the joints).

5.6 Seal the perimeter joint on both sides with a single layer of 50-mm (2-in.) wide duct tape (centered on the joints) as shown in Fig. 4.

**6. Measurements**

6.1 Conduct a sound transmission loss test in accordance

with Test Method E 90.

6.2 The test results may be compared to the values given in Table 1, which were determined in a six-laboratory round robin

mass law at all frequencies. The values determined by the standard for a given specimen are taken to be without bias.

7.2 The between laboratory, 95 % Reproducibility Interval,

**TABLE 1 Mean and Standard Deviation of Sound Transmission Loss Data on a Single Steel Panel<sup>A</sup>**

One-third Octave Band Center, Frequency (Hz)	Average Laboratory Value of Sound Transmission Loss (dB)	Standard Deviation of Results (dB)
100	10.4	2.6
125	11.8	1.2
160	12.8	1.2
200	14.8	1.3
250	16.1	1.2
315	17.5	1.2
400	19.2	0.9
500	20.8	1.2
630	22.7	1.1
800	24.6	1.1
1000	26.4	1.0
1250	28.3	1.1
1600	30.3	1.0
2000	32.3	1.0
2500	34.0	1.0
3150	35.8	1.4
4000	37.4	1.5
5000	39.5	2.0

<sup>A</sup> Refer to 4.2.3 for description of panels.

evaluation conducted from 1983 to 1985. They may also be compared with theoretical values of transmission loss.

6.3 Theoretical values of transmission loss may be calculated using the equations for mass law:<sup>3</sup>

$$TL = 20 \cdot \log fm - 47.7 \quad (1)$$

where:

TL = transmission loss, dB,

$f$  = frequency, Hz, and

$m$  = panel mass, kg/m<sup>2</sup>, or,

$$TL = 20 \cdot \log fw - 33.9 \quad (2)$$

where:

$w$  = panel mass, lb/ft<sup>2</sup>.

6.3.1 In these equations it is assumed that there is no significant sound energy transmitted for grazing incidence sound with angles of incidence between 78 and 90°. The angle of incidence is the angle made between the sound wave front and the normal to the panel.

## 7. Precision and Bias

7.1 Test Method E 90 does not give results that agree with

which is approximately equal to 2.8 times the standard deviation of results, is shown in Table 1. These statistics are based on a six-laboratory round robin evaluation conducted from 1983 to 1985. A report covering the results in detail has been filed at ASTM Headquarters.<sup>4</sup>

7.3 The within laboratory, 95 % Repeatability Interval for this specimen tested in accordance with Test Method E 90, will be determined some time in the future. Evaluations are presently underway.

7.4 The significance of the Repeatability and Reproducibility Intervals is as follows:

7.4.1 *Repeatability Interval, I(r)*—On the basis of test error alone, the absolute value of the difference in two test results obtained in the same laboratory on the same material will be expected to exceed  $I ( r )$  only about 5 % of the time.

7.4.2 *Reproducibility Interval, I(R)*—On the basis of test error alone, the absolute value of the difference in two test results obtained in different laboratories on the same material will be expected to exceed  $I ( R )$  only about 5 % of the time.

## 8. Keywords

8.1 reference specimen; sound transmission loss

<sup>3</sup> Jones, Robert E., "Intercomparisons of Laboratory Determinations of Airborne Sound Transmission Loss," *Journal of the Acoustical Society of America*, Vol 66, No. 1, July 1979, pp. 148–164.

<sup>4</sup> Available from ASTM Headquarters. Request RR: E33-1007.



**APPENDIX**

**(Nonmandatory Information)**

**X1. Record Form—Physical Measurements of Steel Sheets and Panels**

X1.1 A suggested record form for physical measurements of the unassembled and assembled panels is shown in Fig. X1.1.

Panel No.	Mass (Weight) of Steel Sheet, kg/m <sup>2</sup> (lb/ft <sup>2</sup> )	Mass (Weight) of Sheet and Frame, kg/m <sup>2</sup> (lb/ft <sup>2</sup> )	Average <sup>A</sup> Thickness of Steel Sheets, mm (in.)	Width of Panel mm (in. or ft)	Height of Panel mm (in. or ft)
1					
2					
3					
4					

<sup>A</sup> Measured at six locations on each sheet.

**FIG. X1.1 Suggested Record Form**

*ASTM International takes no position respecting the validity of any patent rights asserted in connection with any item mentioned in this standard. Users of this standard are expressly advised that determination of the validity of any such patent rights, and the risk of infringement of such rights, are entirely their own responsibility.*

*This standard is subject to revision at any time by the responsible technical committee and must be reviewed every five years and if not revised, either reapproved or withdrawn. Your comments are invited either for revision of this standard or for additional standards and should be addressed to ASTM International Headquarters. Your comments will receive careful consideration at a meeting of the responsible technical committee, which you may attend. If you feel that your comments have not received a fair hearing you should make your views known to the ASTM Committee on Standards, at the address shown below.*

*This standard is copyrighted by ASTM International, 100 Barr Harbor Drive, PO Box C700, West Conshohocken, PA 19428-2959, United States. Individual reprints (single or multiple copies) of this standard may be obtained by contacting ASTM at the above address or at 610-832-9585 (phone), 610-832-9555 (fax), or service@astm.org (e-mail); or through the ASTM website (www.astm.org).*