



Designation: E 966 – 02

Standard Guide for Field Measurements of Airborne Sound Insulation of Building Facades and Facade Elements¹

This standard is issued under the fixed designation E 966; the number immediately following the designation indicates the year of original adoption or, in the case of revision, the year of last revision. A number in parentheses indicates the year of last reappraisal. A superscript epsilon (ϵ) indicates an editorial change since the last revision or reappraisal.

INTRODUCTION

The sound transmission of a building facade or facade element as measured under field conditions is dependent not only on the physical characteristics of the facade, but also on the characteristics of the incident sound field used to make the measurement. This is also true for laboratory tests of panels using the two-room method described in Test Method E 90; however, the incident sound field in these controlled tests is made uniformly diffuse. The same is approximately true for field measurements of noise reduction and transmission loss by Test Method E 336. Such uniformity is not possible for facade measurements in the field where each situation is unique, resulting in incident sound fields that may range all the way from free field produced by a point source to quasi-diffuse produced by a line source.

At this time, there are insufficient data available to specify a single, standard measurement procedure suitable for all field situations. For this reason, this guide provides a number of alternative test procedures for the measurements of facade field level reduction and transmission loss.

1. Scope

1.1 This guide covers field procedures for measuring the sound level reduction or sound transmission loss of an installed building facade or facade element in specified frequency bands. These values may be used separately to predict interior levels or combined into a single number such as by Classification E 413 (with precautions) or Classification E 1332 to estimate the sound insulating properties of the test element, FOITC, in the field. The results are applicable to installations similar to that tested when exposed to an outdoor sound field similar to that used during the measurement.

1.1.1 The facade element may be the exterior wall of a room in the building, or a portion of that wall such as a door or window, when the remainder of that wall has substantially greater sound insulation than the portion under test.

1.2 To cope with the variety of outdoor test geometry that may be encountered, several testing techniques are presented. These techniques and their general applicability are summarized in Table 1 and Figs. 1-6.

1.3 This guide may be used to determine the outdoor-indoor level reduction (OILR), which is the difference in sound pressure between a specified outdoor sound field and the resulting sound pressure level in the room abutting the test

facade or facade element. The outdoor sound field and its measurement must be thoroughly described. The resulting level reduction or transmission loss value will depend on the outdoor field geometry and the point at which it is measured or represented.

1.4 The values stated in SI units are to be regarded as standard. The values given in parentheses are provided for information only.

1.5 *This standard does not purport to address the safety concerns, if any, associated with its use. It is the responsibility of the user of this standard to establish appropriate safety and health practices and determine the applicability of regulatory limitations prior to use.*

2. Referenced Documents

2.1 ASTM Standards:

- C 423 Test Method for Sound Absorption and Sound Absorption Coefficients by the Reverberation Room Method²
- C 634 Terminology Relating To Environmental Acoustics²
- E 90 Test Method for Laboratory Measurement of Airborne Sound Transmission Loss of Building Partitions²
- E 336 Test Method for Measurement of Airborne Sound Insulation in Buildings²
- E 413 Classification for Rating Sound Insulation²
- E 1332 Classification for Determination of Outdoor-Indoor Transmission Class²

¹ This guide is under the jurisdiction of ASTM Committee E33 on Environmental Acoustics and is the direct responsibility of Subcommittee E33.03 on Transmission.

Current edition approved April 10, 2002. Published June 2002. Originally published as E 966 – 84. Last previous edition E 966 – 99.

² Annual Book of ASTM Standards, Vol 04.06.

TABLE 1 Application Guide to Measurement of Outdoor-Indoor Level Reduction (OILR) of Facade Elements^A

Outdoor Signal Source	Outdoor Microphone Position	Calculation Reference Section	Applications Remarks
Calibrated loudspeaker at $\theta = 45^\circ$ from test element	Incident sound pressure inferred from separate calibration of source	8.3.1, Fig. 1; Eq 4	Use when traffic noise is not available or when outdoor measurement at or near facade is not possible.
Loudspeaker at $\theta = 45^\circ$ from test element	Several locations averaged about 1.2 m 2.4 m from the facade element	8.3.2, Fig. 2; Eq 5	Use when calibrated source or flush measurement is not possible.
Loudspeaker at $\theta = 45^\circ$ from test element	Several locations less than 17 mm from facade element	8.3.3, Fig. 3; Eq 6	Use when traffic noise is not available and when loudspeaker cannot be calibrated.
Traffic or equivalent	Simultaneous measurement remote from the facade	9.5.1, Fig. 4; Eq 8	Source far from facade (that is, consistent traffic or aircraft overflights).
Traffic or equivalent, moving parallel with facade	Simultaneous measurement 2 m (79 in.) from facade	9.5.2, Fig. 5; Eq 9	Suitable when facade faces traffic. Smooth or rough facades. OILR and OITL down to 80 Hz.
Traffic or equivalent, moving parallel with facade	Simultaneous measurement less than 17 mm from facade surface	9.5.3, Fig. 6; Eq 10	Smooth or rough facade element test (for example, window, wall air conditioner, etc.); OILR & OITL to 5000 Hz.

^ASee 5.1, 8.3 and 9.2.

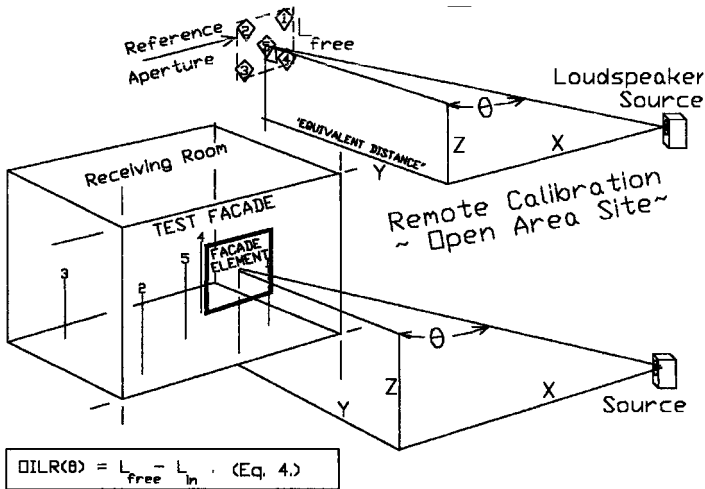

$$OILR(\theta) = L_{free} - L_{in} \quad (\text{Eq. 4.})$$

FIG. 1 Geometry—Calibrated Source Method

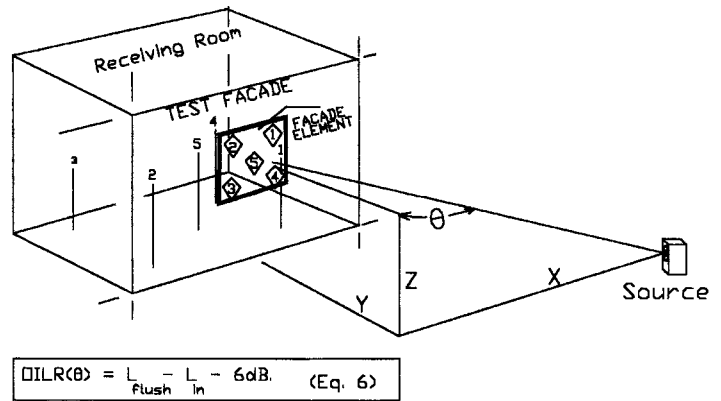

$$OILR(\theta) = L_{flush} - L_{in} - 6\text{dB} \quad (\text{Eq. 6})$$

FIG. 3 Geometry—Flush Method

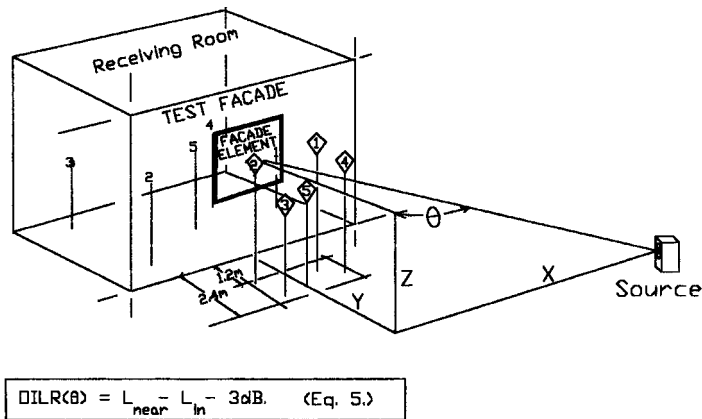

$$OILR(\theta) = L_{near} - L_{in} - 3\text{dB} \quad (\text{Eq. 5.})$$

FIG. 2 Geometry—Nearby Average Method

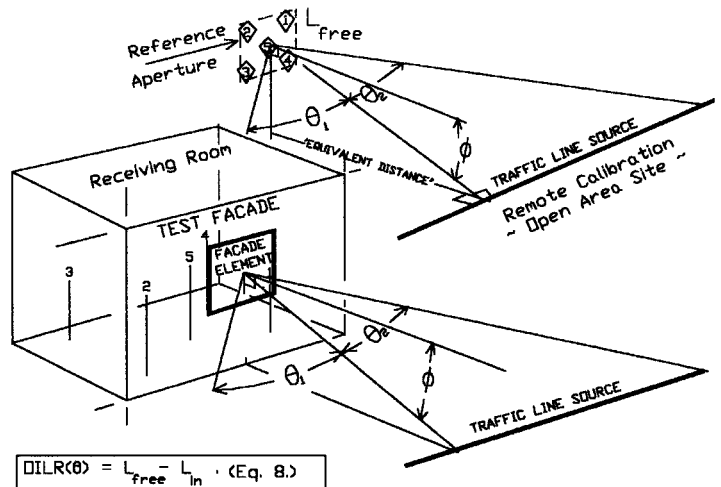

$$OILR(\theta) = L_{free} - L_{in} \quad (\text{Eq. 8.})$$

FIG. 4 Geometry—Equivalent Distance Method

2.2 ANSI Standards:³
 S1.4 Specification for Sound Level Meters

S1.11 Specification for Octave-Band and Fractional-Octave Analog and Digital Filter Sets
 S1.31 Precision Methods for the Determination of Sound Power Levels of Broadband Sources in Reverberation Rooms

2.3 IEC Standards:³
 IEC Publication 651—Sound Level Meters

³ Available from the American National Standards Institute, 11 W. 42nd. St., 13th Floor, New York, NY, 10036.

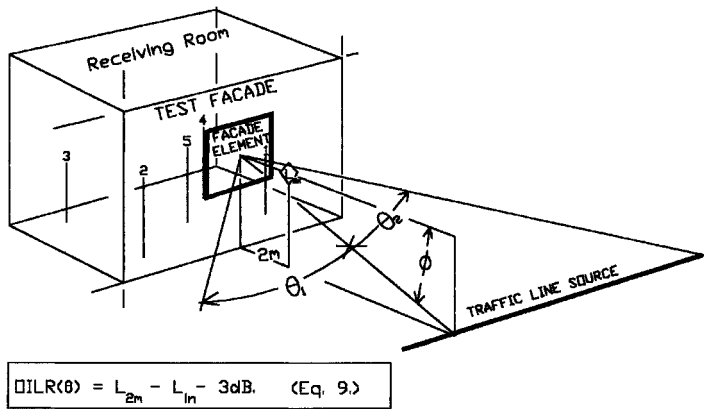

FIG. 5 Geometry—2 m (79 in.) Position Method

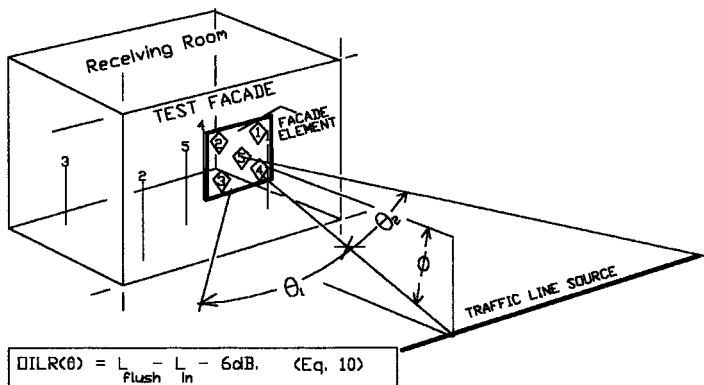

FIG. 6 Geometry and Formulas—Line Source Flush Method

IEC Publication 804 Integrating-Averaging Sound Level Meters

3. Terminology

3.1 *Definitions*—For acoustical terms used in this guide, see Terminology C 634.

3.2 *Definitions of Terms Specific to This Standard:*

3.2.1 *apparent outdoor-indoor transmission loss, apparent OITL* (θ)—the value of outdoor-indoor transmission loss obtained on a test facade element as installed, without flanking tests to identify or eliminate extraneous transmission paths; the apparent OITL is the lower limiting value of the outdoor-indoor transmission loss of the facade element.

3.2.2 *coincidence transmission*—transmission loss which is especially angular dependent (see 8.2.3.2).

3.2.3 *field outside-inside transmission class, FOITC*—the single number rating obtained by Classification E 413 or E 1332 with the OITL values.

3.2.4 *outdoor-indoor level reduction, OILR*—in a specified frequency band, the difference between the time-averaged exterior sound pressure and the space-time average sound pressure in a room of a building.

3.2.4.1 *Discussion*—The direct field sound pressure is from a sound source at a specified angle of incidence, θ , as defined in Fig. 2, or a range of angles in the case of a moving source, which would be present at the facade of the room, were the building and its facade not present.

3.2.5 *outdoor-indoor transmission loss, OITL* (θ)—of a building facade element in a specified frequency band, ten times the common logarithm of the ratio of airborne sound power per unit area incident on the facade element at a specified angle, θ , as defined in Fig. 2, to the sound power transmitted through it and radiated to the interior; the quantity so obtained is expressed in decibels (dB).

3.2.5.1 *Discussion*—The unqualified term OITL (θ) signifies that flanking tests have been performed according to Annex A1 to verify that there was no significant flanking or leakage transmission. In the absence of such tests, the test result may be termed the apparent OITL (see 3.2.1).

3.2.6 *traffic noise*—noise emitted by moving transportation vehicles, such as cars, trucks, locomotives, or aircraft.

4. Summary of Guide

4.1 This guide provides procedures to measure the reduction in sound level from the outdoors to an enclosed room. This outside-inside level reduction is a function of angle, OILR (θ), where θ is the angle of incidence of the outdoor sound. With further measurements under restricted conditions, a basic property of a facade or facade element, the outdoor-indoor transmission loss, OITL (θ), may be determined. This requires that the conditions of Annex A1 be met to demonstrate that flanking of sound around the test specimen is not significant. If it is not possible to meet the conditions of Annex A1, the apparent OITL (θ) is reported. The OILR (θ) and OITL (θ) may be reported for a range of angles.

4.2 *Sources of Test Signal:*

4.2.1 The outdoor sound pressure level produced by a loudspeaker source is either inferred from a previous calibration of the level emitted by that loudspeaker at a specific distance, or it is measured near the facade, or it is measured flush to the facade. When the outdoor sound level is measured near the facade, measurements shall be averaged over several locations near the test specimen to minimize effects of incident and reflected sound wave interference.

4.2.2 In the traffic noise method, movement of sources along a line such as a highway or flight path combined with time averaging will minimize interference effects. To account for source fluctuations using the traffic noise method, the incident sound is measured synchronously with the indoor levels.

4.3 To avoid propagation anomalies and extraneous noise sources, the measurements shall be made without precipitation and when the wind speed is less than 5 m/s (11 mph).

4.4 Measurements are preferably conducted in a series of one-third octave band frequencies from at least 80 to 5000 Hz. Octave band data in the same frequency range are optional.

NOTE 1—Where A-weighted OILR values are desired, A-weighted measurements may be used. These values shall be reported as A-weighted.

5. Significance and Use

5.1 The OILR and OITL produced by the methods described will not correspond to the transmission loss and noise reduction measured by Test Method E 90 and E 336 because of the different angular distributions that may exist in the outdoor

incident sound fields (1)⁴ and the sound intensity distribution across the test facade. Of the three methods cited for measuring the outdoor sound field from a loudspeaker, the free and flush methods are more repeatable. The near method is used only when the free field and the flush methods are not feasible.

5.2 Flanking transmission or unusual field conditions could render the determination of OITL difficult or meaningless. Where the auxiliary tests described in Annex A1 cannot be satisfied, only the apparent OITL or the OILR are to be considered valid.

6. Conditions Required to Typify the Characteristics of a Facade Element

6.1 The facade under test is usually the whole segment of exterior wall common to and enclosing one room (the receiving room). A facade element under test would be only a part of that facade. The room selected for test should be surrounded with equal or better construction, with no obvious leakage paths such as open windows in adjacent spaces. Rooms at the top of a multi-story building might be unsuitable for testing because of flanking transmission through the roof. A room at the corner of a building may be undesirable since sound penetrating the adjoining exterior wall may be difficult to assess.

6.2 If a relatively massive facade contains a low-mass element such as a window, the latter could be considered the element under test on the assumption that it transmits a greater amount of incident sound. A decision should be made whether the test element size is to be defined with or without its perimeter joints and framing.

6.3 Flanking measurement according to Annex A1 should be made blocking the element under test as defined in 6.2. This test determines the degree to which sound transmits through the remainder of the facade. The OITL may be computed with the result of Eq A1.1, and so stated in the report according to 13.1.2.

7. Properties of the Receiving Room Required to Determine OITL(θ) or Apparent OITL(θ)

7.1 The sound transmitted through the test facade element is measured in an adjacent receiving room. The ratio of the incident power to the power transmitted and radiated into the room is calculated using the space- and time-averaged sound pressure levels and the receiving room absorption.

7.2 *Receiving Room Shape and Volume*—The receiving room must form an enclosed space. For determining the OITL or apparent OITL, the room length, width, and height should be all different with the largest dimension no greater than twice the shortest and the test facade dimensions should be at least 2.3 by 2.4 m (7.5 by 8.0 ft).

7.2.1 The volume of the receiving room determines to a large extent the lowest frequency at which the sound fields are adequately uniform; the larger the room, the lower the limiting frequency. In all cases, the room volume must be reported. It is recommended that the room volume be greater than 50 m³ (1770 ft³) for OITL measurement.

7.3 *Diffusion*—For determining an accurate spatial sound pressure level, it is helpful if the room contains diffusing objects such as hard furniture.

7.4 *Receiving Room Absorption Measurement for Determining OITL (θ)*:

7.4.1 It is preferred that the receiving room should have hard wall, ceiling, and floor surfaces. For furnished rooms, it should be reported whether the absorption exceeds that given by the following equation:

$$A_2 = V^{2/3} \quad (1)$$

where:

V = room volume, m³ (ft³), and

A_2 = absorption, m²(sabins).

7.4.2 *Measurement of the Receiving Room Absorption, A₂*:

7.4.2.1 *Reverberation Method (see Test Method C 423)*—The value of A is derived from measurements of the rate of decay of sound pressure level in the receiving room, employing a sound source in the receiving room. The Sabine equation leads to the following equation:

$$A_2 = 0.921 V d/c \quad (2)$$

where d is the rate of decay of reverberant sound in the room, dB/s, or 60 dB/ T , where T is the reverberation time of the room, s .

The speed of sound in the receiving room will change with air temperature. It must be calculated, m/s, as follows:

$$c = 20.047\sqrt{273.05 + t} \quad (3)$$

where t is the air temperature in degrees Celsius.

8. OILR and OITL Measurement with a Fixed (Loudspeaker) Source

8.1 *Measurement Site Background Noise*—Indoor and outdoor levels produced by the loudspeaker should be at least 5 dB above the respective background noise levels in all measurement bands. If the level produced by the test loudspeaker is between 5 and 10 dB above the background level, adjustments for background noise must be applied according to Section 10. It may be necessary to conduct measurements during periods of low indoor and outdoor noise to meet these requirements.

8.2 *Generation of Outdoor Sound Field*:

8.2.1 *Loudspeaker Sound Emission Characteristics*—A single loudspeaker enclosure shall be used. Its directional characteristic should be such that at 2000 Hz the free-field radiated sound pressure up to an angle of 45° shall not be more than 6 dB different from the on-axis sound pressure. It must supply sufficient output in all measurement bands over the range from 80 to 5000 Hz.

8.2.2 *Test Signal*—The electrical signal shall consist of random noise filtered in one-third octave (preferred) or octave bands. Filtering may be used in the source system or in the microphone system, or in both. Bands of random noise may exhibit minor fluctuations in level with time. Measurements should be averaged over a sufficient time interval to account for source level fluctuations. See 9.4 and Note 5.

8.2.3 *Geometry of the Angle of Incidence*—As shown in Fig. 7, the loudspeaker shall be located at a specified angle of incidence, θ , which is the angle between a perpendicular line,

⁴ The boldface numbers in parentheses refer to a list of references at the end of this standard.

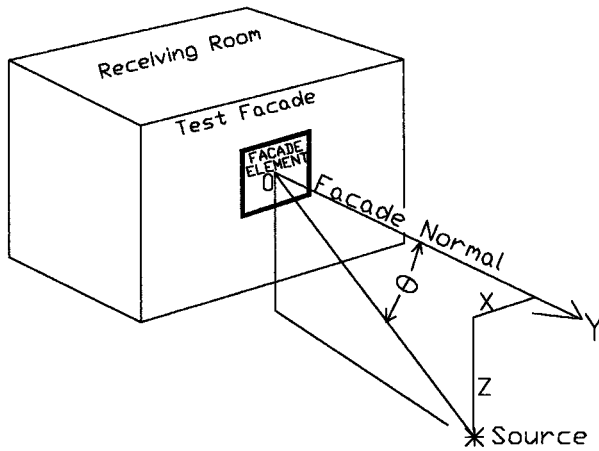

θ = angle of incidence.

FIG. 7 Source Location (*) and θ Definition

OY, at the midpoint of the test facade and the line from that midpoint to the source. In this guide, this angle can lie in any plane, and is calculated according to dimensions and notes given in Fig. 7.

8.2.3.1 When the test objective is to evaluate the performance of a facade element for a particular source location, the test should duplicate the condition of concern as closely as possible. When the test objective is to rate the performance of a variety of facade elements using a single source location, an incident angle of 45° is preferred. If there is a desire to compare results to those obtained in a diffuse sound field, measurements should be made at angles of 15° , 30° , 45° , and 60° . The source positions should preferably be in the vertical plane through the center of the facade element and perpendicular to the element. If the facade has major irregularities such as balconies, additional directions may be needed to provide adequate representation of the facade performance. The preferred set of additional source positions are in the horizontal plane through the center of the facade element. If measurements are made at several angles of incidence, the individual values of OITL (θ) should be reported.

8.2.3.2 The incidence angle for test sound is critical for a facade elements exhibiting strong coincidence transmission (2, 3, 4). The angle of least transmission loss (greatest transparency) depends on panel stiffness, panel mass and sound frequency (5).

8.2.4 *Distance of Source from Test Facade Element*—The source shall be far enough from the facade so that the ratio of the distances from the source in the farthest and nearest parts of the test surface is no more than two. The loudspeaker axis shall be directed toward the center of the test element, favoring the more remote edge only as needed to make the sound pressure variation across that element as small as possible, preferably within 3 dB.

8.3 *Determination of Outdoor Sound Pressure Level:*

8.3.1 *Calibrated Loudspeaker Source Method (Fig. 1)*—This method is feasible when the sound pressure incident on the test facade can be inferred from prior calibration of a source

of constant sound such as a loudspeaker.⁵ The sound pressure level, L , measured at an equivalent distance and direction is assumed to also be the sound pressure incident on the facade without the test facade and without reflections from surrounding building components. This source shall be calibrated in a free-field (echo-free) environment, and at the same distance that the source is to be from the facade. Measurements are made of L at a distance from the source and at an angle from the source (loudspeaker) axis corresponding to the loudspeaker location relative to the test facade (Fig. 1 inset). The test signal input to the source is set to the value that shall be maintained throughout the facade test. This input value should be monitored throughout the test. Appropriate corrections should be applied if necessary. Average the sound pressure level found at five random positions within a reference aperture that corresponds to the facade element under test. See Fig. 1. Each level measurement must be averaged over a sufficient time period (see 8.2.2).

8.3.1.1 The effect of ground and nearby object reflections on the calibration is determined by blocking all known reflection paths with a screen or by applying a sound absorber to nearby surfaces. For purposes of this guide, the calibration site meets the free-field requirement when the L calibration level does not change by more than 1 dB when the screen(s) and absorber(s) are removed.

NOTE 2—When outdoor measurements made proximate to another building facade are influenced by reflections from that other building, it should be so stated in the test report. This fact is especially important when the test noise source is a calibrated loudspeaker or a traffic source at an equivalent distance.

8.3.2 *Outdoor Measurement Near the Facade (Fig. 2)*—Measure the outdoor sound pressure level near the facade. To minimize wave interference effects, average five or more measurements at random distances from the test element, at random positions across the test element, and at varying heights across the test element to meet the requirements of 12.2. The random distances should be in the range of more than 1.2 m and less than 2.5 m (more than 4 ft and less than 8 ft) from the facade. The random positions and random heights should be within the left, right, upper, and lower limits of the test element. If the facade is irregular in shape, see 9.3.2.

8.3.3 *Flush Outdoor Measurement Position (Fig. 3)*—This measurement method is feasible when the facade is smooth and hard or if only one smooth and hard facade element such as a window is under test. Measure the sound pressure with a small condenser microphone 13 mm (1/2 in.) in diameter mounted on or very close to the exterior surface at the midpoint of the test element. The microphone should be within half a diaphragm radius of the surface, but not likely to touch the facade surface or impede the airflow through the microphone grille (see also 11.1.3). It is suggested that up to five measurements about the surface of the test element be averaged.

⁵ The sole source of suitable loudspeakers, known to the committee at this time is Brüel & Kjaer, 2815 Colonnades Court, Norcross, GA (Type 4224 Noise Source). If you are aware of alternative suppliers, please provide this information to ASTM Headquarters. Your comments will receive careful consideration at a meeting of the responsible technical committee,¹ which you may attend.

NOTE 3—The outdoor microphone must be closer than one-quarter wavelength from the surface at the highest frequency of interest and the surface absorption must be very low (6). If the microphone is entirely within 17 mm (5/8 in.) of the surface, it provides accurate flush measurements for frequencies at least up to 2500 Hz (0.05 wavelengths) (7).

8.4 *Indoor Sound Pressure Level Determination*—Measure the average sound pressure level in the room with a moving microphone or a set of fixed microphone positions.

8.4.1 A single moving microphone may be used which moves continuously along a traverse or circular path while satisfying the following conditions:

8.4.1.1 No microphone position shall be closer than 1 m (39 in.) to the inside surface of the exterior wall or to any other boundary or extended surface,

8.4.1.2 For a fixed microphone, a minimum of three microphone positions is required, but more positions may be required to achieve the desired precision (see 12.2), and,

8.4.1.3 The minimum separation of microphone positions should be one-half wavelength or 1 m (39 in.), whichever is less.

8.4.2 Use of only one microphone position is permissible only for OILR measurements. In this case, it should be located from 1.2 m to 1.5 m (4 ft to 5 ft) above the floor, and its exact location with respect to the facade element under test shall be reported. This procedure is not allowed for OITL measurement.

8.5 *Determination of Outdoor-Indoor Level Reduction (OILR)*:

8.5.1 *Calibrated Source Method*—If the incident outdoor level L has been established by prior calibration as in 8.3.1, the value of OILR is calculated using:

$$OILR(\theta) = L_{free} - L_{in}(\theta) \quad (4)$$

where:

- L_{free} = calibrated level, L , and
- $L_{in}(\theta)$ = average sound pressure level in the room enclosed by the test facade, dB, caused by exterior sound incident at angle θ , and
- θ = angle of incidence, that is, the angle between the source position and the perpendicular to the test element midpoint, degrees.

8.5.2 *Nearby Microphone Method*—The average outdoor sound pressure level is measured about 2 m (79 in.) from the test facade as described in 8.3.2. The OILR for that angle is calculated using:

$$OILR(\theta) = L_{near} - L_{in}(\theta) - 3 \text{ dB} \quad (5)$$

8.5.3 *Flush Microphone Method*—If the outdoor sound pressure level has been measured very close to the surface as described in 8.3.3, the OILR value for that angle is calculated using:

$$OILR(\theta) = L_{flush} - L_{in}(\theta) - 6 \text{ dB} \quad (6)$$

8.6 *Measurement of OITL*—The OITL (θ) is calculated using:

$$OITL(\theta) = OILR(\theta) + 10 \log (Scos(\theta)/A_2) + 6 \text{ dB} \quad (7)$$

where:

- S = area of the test facade element, m^2 (ft^2), and
- A_2 = room absorption determined in 7.4, m^2 (sabins).

This OITL measured at an angle θ is valid only for that angle. The OITL cannot be predicted for other angles. To compare the OITL for the facade element with results from Test Method E 90, the sound power transmitted at all incidence angles must be measured. An approximation to this is to measure the sound pressure level at several incidence angles. These angles may be chosen to represent equal areas of a hemisphere, so that the resultant squared pressures can be averaged. For three measurement angles, these angles are 34, 60, and 80°. If a uniform angular increment is more convenient, then a weighting factor must be applied to the measured squared pressure at each angle. For instance, for incidence angles of 15, 30, 45, 60, and 75°, the factor that weights each pressure squared measurement according to the hemispherical solid angle of incidence that it represents is respectively 0.08, 0.15, 0.22, 0.26, and 0.29. If measurements are made at 30 and 60°, the corresponding factor is respectively 0.37 and 0.63.

9. Measurement with Traffic Noise (8) (or Similar Existing Source)

9.1 Traffic noise may be used as the source of noise for the measurement of OILR only. OITL shall only be measured using a controlled source, as described in 8.6.

9.2 *Measurement Site (Fig. 8)*—An acceptable traffic noise site is one for which the test facade is parallel to a straight and level traffic route that is long enough to include angles of incidence up to at least 70° in each direction, and in which the vertical angle of incidence is no greater than 20° at the vehicle location nearest the test facade. If these restrictions are not met, the sound incidence angle at traffic closest approach shall be reported, and this OILR shall not be used to typify the general noise isolation performance of the facade or facade element under test. To ensure adequate indoor signal level to measure OILR over the frequency range required by this guide, the sound spectrum of the vehicle(s) used for such pass-by tests may be augmented or reinforced at the higher frequencies.

9.2.1 For aircraft traffic noise sources, the range of vertical angles is large and this range can vary for each noise event. Also, the noise level varies significantly as described in 9.3.1. Measurements with aircraft noise sources should be restricted to components such as roofs, ventilators, and complete structures that cannot be readily tested by other means. When flying

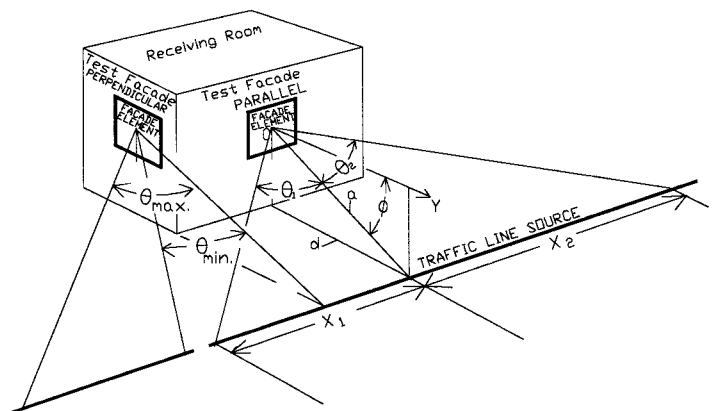

FIG. 8 Location of Traffic Line Source and Orientation of Incidence Angles with Respect to Traffic Flow and Facade Normal

aircraft provide the test noise, the sound incidence angle at closest approach shall be reported.

9.3 Determination of Outdoor Traffic Noise Level:

9.3.1 Traffic Noise Measurement at an Equivalent Distance (Fig. 4)—This method is used with steady and uniform roadway traffic as a noise source. Measure the traffic noise sound pressure level, L , outdoors at a reference aperture (Fig. 4 inset), remote from any reflecting surfaces other than the ground, at the same distance as the test facade is from the traffic. The indoor and outdoor sound pressure levels shall be measured simultaneously as described in 9.5. If traffic is nonuniform, or if overflying aircraft are used as the noise source, the average of the indoor noise level and the outdoor noise level must each properly represent each vehicle passage as described in Note 5. It is applicable to aircraft flyovers when the flight path location is known.

9.3.2 Traffic Noise Measurement at the 2 m (79 in.), Position (Fig. 5)—Measure the traffic noise outdoors at a point opposite the center of the facade element under test, at a distance of 2 m (79 in.) from the outermost portion of the facade. If there are major protrusions such as balconies, the test point shall be 2 m (79 in.) outside the protruding section, and the protrusion should be identified as part of the element under test.

9.3.3 Traffic Noise Measurement at the Flush Position (Fig. 6)—This method may be used when the facade is smooth or if only one element of a facade such as a window is under test. Measure the traffic noise outdoors flush with the facade surface at its center. Use a small diameter microphone according to 8.3.3 and Note 3.

9.4 Determination of Indoor Sound Pressure Level—The indoor measurement positions shall be as described in 8.4. For measurement procedures, see 9.5.

9.5 Measurement Procedures for Fluctuating Traffic Noise—Measure the average sound pressure level of all fluctuating noises using an integrating averaging sound level meter meeting the requirements of IEC 804-1985. Outdoor and indoor measurements must be averaged over the same time interval (see 8.2.2). The time averaging of both indoor and outdoor levels shall be done for each indoor microphone position. Background levels, outdoors and indoors, may also be verified during each measurement, and corrections made if necessary (see Section 10).

NOTE 4—An outdoor-indoor microphone pair can be used to measure OILR with a continuous traffic noise source. The level difference is measured, then the indoor microphone is moved and this procedure is repeated for each of at least three different indoor microphone positions located according to 8.4.1.2. These results are then averaged.

NOTE 5—For aircraft flyover noise, or where natural traffic is sparse simultaneously measure the integrated average sound level (that is, the sound exposure level, SEL) of the outdoor and indoor sound pressures for individual aircraft flyovers. Record the range of angles occurring for each flyover. Where the outdoor microphone is remote from the test facade, the averaging or integrating start and stop times must account for the aircraft transit time between the remote location and the test facade.

9.6 Calculation of OILR for the Traffic Noise Methods:

9.6.1 Remote Outdoor Sound Field Measurement (see 9.3.1)—Calculate OILR as:

$$OILR (line) = L_{free} - L_{in} \quad (8)$$

where:

L_{free} = remote traffic outdoor sound pressure level, L , and
 L_{in} = simultaneous space average sound pressure level in the receiving room.

9.6.2 Outdoor Measurements at 2 m (79 in.) from the Facade (see 9.3.2)—Calculate OILR as follows:

$$OILR (line) = L_{2m} - L_{in} - 3 \text{ dB} \quad (9)$$

where:

L_{2m} = equivalent sound pressure level outdoors at a point 2 m (79 in.) from the facade test element, dB.

9.6.3 Outdoor Sound Field Measurements Flush to the Facade (see 9.3.3)—Calculate OILR as follows:

$$OILR (line) = L_{flush} - L_{in} - 6 \text{ dB} \quad (10)$$

9.7 Comparison with the US DOT Methods—The United States Federal Highway Administration and Federal Aviation Administration (FHWA and FAA) have evolved facade noise insulation measurements and single number rating methods:

9.7.1 FHWA Method (9)—The sound pressure level is measured A-weighted or in full-octave or one-third octave bands from 125 to 4000 Hz. The A-weighted level can be computed from octave and one-third octave data. The outdoor microphone is placed approximately 25 mm (1 in.) from the facade surface. Between one and four microphones are placed in the receiving room. Roadway traffic sound is used as the noise source. The maximum sound level detected by each microphone is recorded. This procedure is essentially a point source measurement, since the maximum level is caused by the loudest source at the moment that it passes through the position where θ is zero. A noise reduction value is computed with a formula similar to Eq 6. FHWA experience is that the 6 dB factor is 5 dB in practice.

9.7.2 FHWA-EWR Method (9)—An outdoor sound field is assumed to be incident on the facade. One-third octave band measurements are used. The receiving room absorption is measured as in 7.4. Level reduction in one-third octave bands is determined by this guide. A transmission loss value is calculated as:

$$\text{transmission loss} = \text{level reduction} + 10 \log (S/A) + 6 \quad (11)$$

9.7.2.1 External Wall Rating—A single number rating value is derived from transmission loss results over the frequency range from 125 Hz through 4000 Hz in a manner analogous to that found in Classifications E 413 or E 1332, except that a different criterion curve is used to emphasize the low frequency content of exterior noise. This value is called the external wall rating (EWR).

9.7.2.2 A-Weighted Level Reduction—The EWR can be used, with corrections for room absorption and traffic type, to estimate the interior A-weighted level.

9.7.3 FAA Method (10)—The outdoor microphone is mounted either close to the facade or on a remote pole 6 m (20 ft) above ground level to measure the free-field sound level. Aircraft overflight sound is used as the noise source. The maximum sound level is recorded for each microphone. The A-weighted noise reduction is calculated for the outdoor measurement near the surface, or as the level difference directly similar to Eq 4 for the remote outdoor measurement.

10. Adjustments for Background Noise

10.1 Verify that the outdoor and indoor levels are from the designated test source (traffic or loudspeaker) and not from some extraneous background noise source. This requirement can affect the choice of test method (see 4.1.2). At each measurement position, the background level should be at least 5 dB below the level of signal and background combined. Adjustments shall be made unless the background level is more than 10 dB below the combined level. If the background level is between 5 and 10 dB below the combined signal and background combined, the adjusted value of the signal level is calculated as follows:

$$L_s = 10 \log (10^{L_{sb}/10} - 10^{L_b/10}) \quad (12)$$

where:

- L_b = background noise level, dB,
- L_{sb} = level of signal and background combined, dB, and
- L_s = adjusted signal level, dB.

NOTE 6—If the test signal consists of naturally occurring noise such as traffic noise, determine the background level when the outdoor test noise is low or intermittent (see 9.3.1).

11. Instrumentation

11.1 Measurements of Sound Pressure Level:

11.1.1 *Loudspeaker Source Method*—A sound level meter or equivalent instrumentation that meets Type 2 requirements of ANSI S1.4 is required for the method in Section 8.

11.1.2 *Traffic Noise Source*—Two similar microphone systems are required for simultaneous measurement of indoor and outdoor levels for the method in Section 9. Process the data to obtain average sound pressure levels. The microphones and indicating systems shall meet the Type 2 requirements of ANSI S1.4 or IEC 651. Any instrumentation system that achieves this result to the precision of 12.2, may be used. An integrating-averaging sound level meter meeting the requirements of IEC 804 is recommended for variable noise sources such as a vehicular passby.

11.1.3 *Windscreen*—The microphone should be fitted with a wind screen of such design that the system meets the Type 2 requirements for outdoor measurements. For the flush method described in 8.3.3, a modified foam windscreen partly cut away to permit placement of the microphone close to the surface may be used.

11.2 *Filters*—Filters for defining the frequency bands used shall meet the Order 3 requirements of ANSI S1.11 for one-third octave and for octave-band filters.

11.3 *Calibration*—The calibration of all measurement systems shall be verified at one frequency before (and preferably after) each series of tests at a given site.

11.4 *Batteries*—If instruments containing batteries are used, the battery voltages shall be checked before and after a test series is made.

12. Precision of Determination of OITL for a Facade Element

12.1 Because of the nonuniform exterior and interior sound fields that can exist near facade elements, Section 8 measures sound levels at a set of five different locations for the outdoor

and for the indoor locations. Where a microphone scan in accordance with 8.4.1 is used, the resulting single measurement may be used place of that set and the standard deviation, s , for that set is made zero. In Section 7, the absorption, A_2 , was measured by a series of independent decays. Compute the standard deviation of the observed level s_o for outdoor sound, s_I for indoor sound and $s_A = \pm \Delta A/A$ for the standard deviation of determination of area, A_2 . The corresponding uncertainties at 95 % confidence are as_o , as_I and as_A , where the factors of confidence, a , corresponding to the number of observations involved is given in Table 2. The 95 % uncertainty of the outdoor-indoor transmission loss s_{OITL} is calculated as follows:

$$s_{OITL} = ((as_o)^2 + (as_I)^2 + 18.86(as_A)^2)^{1/2} \quad (13)$$

NOTE 7—A more detailed discussion of procedures for combining uncertainties is given in Ref. (11).

12.2 It is recommended that sufficient data be taken to achieve an uncertainty of not more than ± 4 dB at 80, 125, 160, and 200 Hz, ± 3 dB from 250 to 500 Hz, and ± 2 dB for frequency bands higher than 500 Hz, all at a confidence level of 95 %.

13. Report

13.1 The test report should include the following:

13.1.1 Provide a statement, if true in every respect, that the test was performed in accordance with one of the methods described in this guide and state which method was followed.

13.1.2 Describe the test site: the dimensions and construction of the facade, the dimensions and furnishings of the

TABLE 2 Factors for Calculating 95 % Confidence Limits for Averages (12)

Number of Measurements	Confidence Limit Factor, ($\bar{X} \pm a \cdot s$) ^A
n	a
4	1.591
5	1.241
6	1.050
7	0.925
8	0.836
9	0.769
10	0.715
11	0.672
12	0.635
13	0.604
14	0.577
15	0.554
16	0.533
17	0.514
18	0.497
19	0.482
20	0.468
21	0.455
22	0.443
23	0.432
24	0.422
25	0.413

^ALimits that may be expected to include the “true” average, \bar{X} , 95 times in 100 in a series of measurements, each involving a single sample of observation.

receiving room, whether the room was highly absorbent, and the condition of operable windows or doors (open or closed). If auxiliary tests are done, for example to investigate flanking transmission or to determine the sound transmission loss of a portion of the facade, these procedures also shall be reported.

13.1.3 Cite the specific test method used and essential details of the test procedure. If the traffic noise method is used, describe the traffic flow and its location relative to the facade. If a loudspeaker source is used, report the characteristics of the loudspeaker and its location relative to the test facade. If a calibrated loudspeaker source was used, report the method of test and free-field determination. If the flush microphone position is used, report the microphone type, orientation, and spacing to the facade exterior surface.

13.1.4 Identify the instruments used and the measurement and calibration procedures (including microphone calibration). For a time-varying noise source such as traffic, describe the method of determining equivalent sound pressure levels. Report band filtering method if different from one-third octave bands (that is, octave or A-weighting filters).

13.1.5 If possible, list results according to frequency and clearly identified as OILR, OITL, or apparent OITL.

13.1.6 Record precision of the results, in terms of the 95 % confidence limits according to Section 12.

13.1.7 Identify OITC values as being FOITC or apparent FOITC (see 13.1.5 and 3.2.1). The single number rating, OITC, is intended to use TL values as determined using Test Method E 90 to rate the effectiveness of a building facade element at reducing transportation noise intrusion. The rating is described in Classification E 1332. When applied to the OITL values obtained here, it should be termed “field” or FOITC.

14. Precision and Bias

14.1 *Precision*—No body of experience in the use of this guide exists at present; however, it is estimated that the repeatability standard deviation of the test procedure is of the order of 2 to 4 dB, depending on frequency (see 12.2).

14.2 *Bias*—The bias of test methods referenced in this guide have not been established and await a round robin of OITL measurements.

14.3 The principal aspect of these test procedures that degrades precision and bias, especially for OITL measurement, is the wide range of exterior sound field configurations.

15. Keywords

15.1 calibrated loudspeaker; doors; facade; flanking; noise reduction; outdoor noise field; traffic noise; transmission loss; windows

ANNEX

(Mandatory Information)

A1. TESTS FOR ASSESSING FLANKING TRANSMISSION (PATHS OTHER THAN THROUGH THE TEST ELEMENT)

A1.1 Introduction:

A1.1.1 The formulas provided in this guide determine the outdoor-indoor transmission loss of the test facade presuming that all the sound reaching the receiving room is transmitted through the test element. In practical testing, some sound may find its way through adjacent elements (flanking transmission).

A1.1.2 To provide a better estimate of the true OITL of the test element alone, a flanking test is applied. The sound transmitted into the receiving room by flanking paths is identified by blocking the test specimen and repeating the measurement. Sound transmitted under this condition may be eliminated or corrections made for it.

A1.1.3 The tests given in A1.2-A1.4 apply to a test element, which can be the entire facade, such as a wall, or to a test element which forms only part of that facade, such as a window. In applying this procedure to the test element (see the procedure in A1.3), specific attention is given to joints between the test element and the remainder of the facade.

NOTE A1.1—In the case of windows or doors, the frame (with its closure hardware and seals) is usually considered as part of the test specimen; in this case, the blocking should cover the frame.

A1.2 *Specimen and Perimeter Integrity*—This survey is recommended before proceeding to OILR or OITL measurements:

A1.2.1 To compare sound transmitted through the test facade or element to that transmitted elsewhere, survey the sound levels within a few millimetres of the various surfaces of the receiving room. This may be done with a stethoscope, a sound level meter, and headphones. A more revealing method is to sense the vibration of each room surface with a low mass vibration transducer placed on each of the room surfaces in turn. Identify major air leaks through joints or local defects with the open end of the air tube of a stethoscope, used as a probe at all such locations.

NOTE A1.2—In conducting the airborne sound survey, be aware of the normal buildup of sound in a room near any reflecting surface and in the intersecting corner of any two or three reflecting surfaces.

A1.2.2 *Remedial Procedures*—Reduce significant sound transmission through surfaces or elements not included in the specimen. For example (unless it forms part of the test specimen), a leaky joint can be taped or caulked, a ventilator opening can be covered, or filler panels around windows or air conditioners may be made more massive. All remedial steps should be reported.

A1.3 Facade Flanking Test Procedure:

A1.3.1 *Blocking Panel*—Measure the apparent OITL. Cover the interior side of the test facade or element with an additional panel designed to reduce transmission through the

test element by at least 10 dB. A suitable construction consists of a layer of freestanding or lightly supported plywood or gypsum board weighing about 10 kg/m² (2 lb/ft²), spaced at least 100 mm (4 in.) from the test facade or element. Fill the space with soft sound absorbing material such as glass fiber batts. Seal all panel joints and perimeter with tape, gaskets, or caulking compound.

A1.3.2 *Repeat Tests*—Measure the apparent OITL of the modified test element. Compare with the initial OITL measurement.

A1.3.3 *Assessment of Results*—If the apparent OITL of the modified element is at least 10 dB higher in every one-third octave band than the initially-measured OITL, then the initial measurements may represent the true OITL of the test element.

A1.3.3.1 If the difference in apparent OITL is less than 5 dB, proceed to A1.4.

A1.3.3.2 If the difference is between 5 and 10 dB, estimate the true OITL by treating level measurements with the test

element blocked off as background noise for the same outdoor level in each case (see Section 10). Adapting Eq 12:

$$L_s = 10 \log (10^{(L_{ab}/10)} - 10^{(L_b/10)}) \quad (\text{A1.1})$$

where:

- L_b = indoor level with the test element blocked off,
- L_{ab} = initial indoor level with test element exposed, and
- L_s = adjusted indoor level due to transmission through the test element alone.

A1.4 *Supplementary Flanking Tests*—If blocking the test specimen reduces the receiving room level by less than 5 dB, increase the transmission loss of the blocking panel or block off other possible sound transmitting paths into the room. The tests given in A1.2 may provide guidance in choosing the next step. The procedure given in A1.3 may be repeated until the requirements of A1.3.3 are met.

REFERENCES

- (1) Donovan, P. R., Flynn, D. R., and Yaniv, S. L., "Highway Noise Criteria Study: Outdoor/Indoor Noise Isolation," *Technical Note 1113-2*, National Bureau of Standards, 1980.
- (2) Jones, R. E., "Intercomparisons of Laboratory Determinations of Airborne Sound Transmission Loss," *Journal of the Acoustical Society of America*, Vol 66, 1970, pp. 148–164.
- (3) Quirt, J. D., "Acoustic Insulation Factor: A Rating for the Insulation of Buildings Against Outdoor Noise," *Building Research Note 148*, June 1979 (Revised June 1980), National Research Council, Canada.
- (4) Cremer, L. and Heckel, M. *Structure-Borne Sound*, Springer-Verlag, 1988, Chapter VI, Part 6.
- (5) Ver, I. and Holmer, C. *Noise and Vibration Control*, 1971, Institute of Noise Control Engineers, Chapter 11, pp 281–283.
- (6) Waterhouse, R. V., "Interference Patterns in Reverberant Sound Fields," *Journal of the Acoustical Society of America*, Vol 27, 1955, pp. 247–258.
- (7) Nash, A., "Facade Sound Insulation—A Field Study," *Inter-Noise 84 Proceedings*, Noise Control Foundation, Poughkeepsie, NY, pp. 593–596.
- (8) Lewis, P. T., "A Method for Field Measurements of the Transmission Loss of Building Facades," *Journal of Sound and Vibration*, Vol 33, Part 2, 1974, pp. 127–141.
- (9) "Background Report on Outdoor-Indoor Noise Reduction Calculation Procedures Employing the Exterior Wall Noise Rating (EWN) Method," Report No. FHWA-TS-77-220, Section 2.3.
- (10) "Study of Soundproofing Public Buildings Near Airports," Report No. DOT-FAA-AEQ-77-9, April 1977, Section 4.2.2.
- (11) Taylor, J. R., *An Introduction to Error Analysis, the Study of Uncertainties in Physical Measurements*, University Science Books, Mill Valley, CA, 1982.
- (12) *Manual on Presentation of Data and Control Chart Analysis*, ASTM STP 150, ASTM, 1976.

ASTM International takes no position respecting the validity of any patent rights asserted in connection with any item mentioned in this standard. Users of this standard are expressly advised that determination of the validity of any such patent rights, and the risk of infringement of such rights, are entirely their own responsibility.

This standard is subject to revision at any time by the responsible technical committee and must be reviewed every five years and if not revised, either reapproved or withdrawn. Your comments are invited either for revision of this standard or for additional standards and should be addressed to ASTM International Headquarters. Your comments will receive careful consideration at a meeting of the responsible technical committee, which you may attend. If you feel that your comments have not received a fair hearing you should make your views known to the ASTM Committee on Standards, at the address shown below.

This standard is copyrighted by ASTM International, 100 Barr Harbor Drive, PO Box C700, West Conshohocken, PA 19428-2959, United States. Individual reprints (single or multiple copies) of this standard may be obtained by contacting ASTM at the above address or at 610-832-9585 (phone), 610-832-9555 (fax), or service@astm.org (e-mail); or through the ASTM website (www.astm.org).