



Standard Test Methods for Maximum Index Density and Unit Weight of Soils Using a Vibratory Table¹

This standard is issued under the fixed designation D 4253; the number immediately following the designation indicates the year of original adoption or, in the case of revision, the year of last revision. A number in parentheses indicates the year of last reapproval. A superscript epsilon (ϵ) indicates an editorial change since the last revision or reapproval.

1. Scope *

1.1 These test methods cover the determination of the maximum-index dry density/unit weight of cohesionless, free-draining soils using a vertically vibrating table. The adjective “dry before density or unit weight is omitted in the title and remaining portions of this standard to be consistent with the applicable definition given in Section 3 on Terminology.

1.2 Systems of Units:

1.2.1 The testing apparatus described in this standard has been developed and manufactured using values in the gravitational or inch-pound system. Therefore, test apparatus dimensions and mass given in inch-pound units are regarded as the standard.

1.2.2 It is common practice in the engineering profession to concurrently use pounds to represent both a unit of mass (lbm) and a unit of force (lbf). This implicitly combines two separate systems of units; that is, the absolute system and the gravitational system. It is scientifically undesirable to combine the use of two separate sets of inch-pound units within a single standard. This standard has been written using the gravitational system of units when dealing with the inch-pound system. In this system, the pound (lbf) represents a unit of force (weight). However, balances or scales measure mass; and weight must be calculated. In the inch-pound system, it is common to assume that 1 lbf is equal to 1 lbm. While reporting density is not regarded as nonconformance with this standard, unit weights should be calculated and reported since the results may be used to determine force or stress.

1.2.3 The terms density and unit weight are often used interchangeably. Density is mass per unit volume whereas unit weight is force per unit volume. In this standard density is given only in SI units. After the density has been determined, the unit weight is calculated in SI or inch-pound units, or both.

1.3 Four alternative methods are provided to determine the maximum index density/unit weight, as follows:

1.3.1 *Method 1A*—Using oven-dried soil and an electromagnetic, vertically vibrating table.

1.3.2 *Method 1B*—Using wet soil and an electromagnetic, vertically vibrating table.

1.3.3 *Method 2A*—Using oven-dried soil and an eccentric or cam-driven, vertically vibrating table.

1.3.4 *Method 2B*—Using wet soil and an eccentric or cam-driven vertically vibrating table.

1.4 The method to be used should be specified by the individual assigning the test.

1.4.1 The type of table to be used (Method 1 or 2) is likely to be decided based upon available equipment.

NOTE 1—There is evidence to show that electromagnetic tables yield slightly higher values of maximum index density/unit weight than the eccentric or cam-driven tables.

1.4.2 It is recommended that both the dry and wet methods (Methods 1A and 1B or 2A and 2B) be performed when beginning a new job or encountering a change in soil types, as the wet method can yield significantly higher values of maximum index density/unit weight for some soils. Such a higher maximum index density, when considered along with the minimum index density/unit weight, Test Methods D 4254, will be found to significantly affect the value of the relative density (3.2.8) calculated for a soil encountered in the field. While the dry method is often preferred because results can usually be obtained more quickly, as a general rule the wet method should be used if it is established that it produces maximum index densities/unit weights that would significantly affect the use/application of the value of relative density.

1.5 These test methods are applicable to soils that may contain up to 15 %, by dry mass, of soil particles passing a No. 200 (75- μ m) sieve, provided they still have cohesionless, free-draining characteristics (nominal sieve dimensions are in accordance with Specification E 11). Further, these test methods are applicable to soils in which 100 %, by dry mass, of soil particles pass a 3-in. (75-mm) sieve.

1.5.1 Soils, for the purpose of these test methods, shall be regarded as naturally occurring cohesionless soils, processed particles, or composites or mixtures of natural soils, or mixtures of natural and processed particles, provided they are free draining.

1.6 These test methods will typically produce a higher maximum dry density/unit weight for cohesionless, free-draining soils than that obtained by impact compaction in which a well-defined moisture-density relationship is not apparent. However, for some soils containing between 5 and 15 % fines, the use of impact compaction (Test Methods D 698 or D 1557) may be useful in evaluating what is an appropriate

¹ This standard is under the jurisdiction of ASTM Committee D18 on Soil and Rock and are the direct responsibility of Subcommittee D18.03 on Texture, Plasticity, and Density Characteristics of Soils.

Current edition approved June 10, 2000. Published September 2000. Originally published as D 4253 – 83 . Last previous edition D 4253 – 93 (1996).

*A Summary of Changes section appears at the end of this standard.

maximum index density/unit weight.

1.7 For many types of free-draining, cohesionless soils, these test methods cause a moderate amount of degradation (particle breakdown) of the soil. When degradation occurs, typically there is an increase in the maximum index density/unit weight obtained, and comparable test results may not be obtained when different size molds are used to test a given soil.

1.8 *This standard does not purport to address all of the safety concerns, if any, associated with its use. It is the responsibility of the user of this standard to establish appropriate safety and health practices and determine the applicability of regulatory limitations prior to use.*

2. Referenced Documents

2.1 ASTM Standards:

- C 127 Test Method for Specific Gravity and Absorption of Coarse Aggregate²
- D 422 Test Method for Particle-Size Analysis of Soils³
- D 653 Terminology Relating to Soil, Rock and Contained Fluids³
- D 698 Test Method for Laboratory Compaction Characteristics of Soil Using Standard Effort (12 400 ft-lbf/ft³(600 kN-m/m³))
- D 854 Test Methods for Specific Gravity of Soil Solids by Water Pycnometer³
- D 1140 Test Methods for Amount of Materials in Soils Finer Than the No. 200 (75- μ m) Sieve³
- D 1557 Test Method for Laboratory Compaction Characteristics of Soil Using Modified Effort (56 000 ft-lbf/ft³(2700 kN-m/m³))
- D 2216 Test Method for Laboratory Determination of Water (Moisture) Content of Soil and Rock by Mass³
- D 2487 Practice for Classification of Soils for Engineering Purposes (Unified Soil Classification System)³
- D 2488 Practice for Description and Identification of Soils (Visual-Manual Procedure)³
- D 3740 Practice for Minimum Requirements for Agencies Engaged in the Testing and/or Inspection of Soil and Rock as Used in Engineering Design and Construction³
- D 4254 Test Methods for Minimum Index Density and Unit Weight of Soils and Calculation of Relative Density³
- D 4753 Specification for Evaluating, Selecting, and Specifying Balances and Scales for Use in Testing Soil, Rock, and Related Construction Materials³
- D 6026 Practice for Using Significant Digits in Geotechnical Data⁴
- E 11 Specification for Wire-Cloth Sieves for Testing Purposes⁵
- E 177 Practice for Use of the Terms Precision and Bias in ASTM Test Methods⁵
- E 691 Practice for Conducting and Interlaboratory Study to Determine the Precision of a Test Method⁵

3. Terminology

3.1 *Definitions:* For common definitions in this standard

² Annual Book of ASTM Standards, Vol 04.02.
³ Annual Book of ASTM Standards, Vol 04.08.
⁴ Annual Book of ASTM Standards, Vol 04.09.
⁵ Annual Book of ASTM Standards, Vol 14.02.

refer to Terminology D 653.

3.2 Definitions of Terms Specific to This Standard:

3.2.1 *dry density/unit weight*, ρ_d or γ_d , n —the dry density/unit weight of a soil deposit or fill at the given void ratio.

3.2.2 *given void ratio*, e , n —the in situ or stated void ratio of a soil deposit or fill.

3.2.3 *maximum index density/unit weight*, ρ_{dmax} or γ_{dmax} , n —the reference dry density/unit weight of a soil in the densest state of compactness that can be attained using a standard laboratory compaction procedure that minimizes particle segregation and breakdown.

3.2.4 *maximum index void ratio*, e_{max} , n —the reference void ratio of a soil at the minimum index density/unit weight.

3.2.5 *minimum index density/unit weight*, ρ_{dmin} or γ_{dmin} , n —the reference dry density/unit weight of a soil in the loosest state of compactness at which it can be placed using a standard laboratory procedure which prevents bulking and minimizes particle segregation.

3.2.6 *minimum index void ratio*, e_{min} , n —the reference void ratio of a soil at the maximum index density/unit weight.

3.2.7 *relative density*, D_d , n —the ratio, expressed as a percentage, of the difference between the maximum index void ratio and any given void ratio of a cohesionless, free-draining soil; to the difference between its maximum and minimum index void ratios. The equation is as follows:

$$D_d = \frac{e_{max} - e}{e_{max} - e_{min}} \times 100 \quad (1)$$

or, in terms of corresponding dry densities

$$D_d = \frac{\rho_{dmax}(\rho_d - \rho_{dmin})}{\rho_d(\rho_{dmax} - \rho_{dmin})} \times 100 \quad (2)$$

in terms of corresponding or dry unit weights

$$D_d = \frac{\gamma_{dmax}(\gamma_d - \gamma_{dmin})}{\gamma_d(\gamma_{dmax} - \gamma_{dmin})} \quad (3)$$

3.2.8 *percent compaction or relative compaction*, R_c , n —the ratio, expressed as a percentage, of the dry density/unit weight of a given soil to its maximum index density/unit weight. The equation is:

$$R_c = \frac{\rho_d}{\rho_{dmax}} \times 100 \quad (4)$$

or

$$R_c = \frac{\gamma_d}{\gamma_{dmax}} \times 100 \quad (5)$$

3.2.9 *density index*, I_d —the ratio, expressed as a percentage, of the difference between any given dry density/unit weight and the minimum index density/unit weight of a given cohesionless soil to the difference between its maximum and minimum index densities/unit weights. The equation is:

$$I_d = \frac{\rho_d - \rho_{dmin}}{\rho_{dmax} - \rho_{dmin}} \times 100 \quad (6)$$

or

$$I_d = \frac{\gamma_d - \gamma_{dmin}}{\gamma_{dmax} - \gamma_{dmin}} \quad (7)$$

4. Summary of Test Method

4.1 The maximum index density/unit weight of a given

free-draining soil is determined by placing either oven-dried or wet soil in a mold, applying a 2-lb/in.²(14-kPa) surcharge (dead weight) to the surface of the soil, and then vertically vibrating the mold, soil, and surcharge. Use either an electromagnetic, eccentric, or cam-driven vibrating table having a sinusoid-like time-vertical displacement relationship at a double amplitude of vertical vibration (peak-to-peak) of about 0.013 in. (0.33 mm) for 8 min at 60 Hz or about 0.019 in. (0.48 mm) for 10 min at 50 Hz. The maximum index density/unit weight is calculated by dividing the oven-dried mass/weight of the densified soil by its volume (average height of densified soil times area of mold).

5. Significance and Use

5.1 For many cohesionless, free-draining soils, the maximum index density/unit weight is one of the key components in evaluating the state of compactness of a given soil mass that is either naturally occurring or placed by man (fill).

5.1.1 Relative density and percent compaction are commonly used for evaluating the state of compactness of a given soil mass. Density/unit weight index is also sometimes used. See Section 3 for descriptions of terms.

5.2 It is generally recognized that either relative density or percent compaction is a good indicator of the state of compactness of a given soil mass. However, the engineering properties, such as strength, compressibility, and permeability of a given soil, compacted by various methods to a given state of compactness can vary considerably. Therefore, considerable engineering judgment must be used in relating the engineering properties of soil to the state of compactness.

5.3 An absolute maximum density/unit weight is not necessarily obtained by these test methods.

NOTE 2—In addition, there are published data to indicate that these test methods have a high degree of variability.⁶ However, the variability can be greatly reduced by careful calibration of equipment, including the vibrating table, and careful attention to proper test procedure and technique.

NOTE 3—The quality of the result produced by this standard is dependent on the competence of the personnel performing it, and the suitability of the equipment and facilities used. Agencies that meet the criteria of Practice D 3740, generally, are considered capable of competent and objective testing/sampling/inspection/etc. Users of this standard are cautioned that compliance with Practice D 3740 does not in itself assure reliable results. Reliable results depend on many factors; Practice D 3740 provides a means of evaluating some of those factors.

5.4 The double amplitude of vertical vibration has been found to have a significant effect on the density obtained.⁶ For a particular vibrating table and mold assembly, the maximum index density/unit weight of a given material may be obtained at a double amplitude of vibration other than the double amplitude of 0.013 ± 0.002 in. (0.33 ± 0.05 mm) at a frequency of 60 Hz or 0.019 ± 0.003 in. (0.48 ± 0.08 mm) at 50 Hz required in this method; that is, dry density/unit weight may initially increase with increasing double amplitude of vibration, reach a peak, and then decrease with further increases in double amplitude of vibration. Furthermore, the relationship between the peak density/unit weight and optimum

double amplitude of vibration (double amplitude of vibration where peak density/unit weight occurs) can vary with various soil types and gradations. For this reason, these methods allow the use of double amplitudes of vibration other than that described above, in special circumstances as provided in 11.1.6.3.

5.5 The use of the standard molds (6.1.1) has been found to be satisfactory for most soils requiring maximum index-density/unit weight testing. Special molds (6.1.2) shall only be used when the test results are to be applied in conjunction with design or special studies and there is not enough soil to use the standard molds. Such test results should be applied with caution as maximum index densities/unit weights obtained with the special molds may not agree with those that would be obtained using the standard molds.

6. Apparatus

6.1 *Mold Assembly*—An example of a typical mold assembly is shown in Fig. 1. Individual components and accessories shall be as follows:

6.1.1 *Standard Molds*—Cylindrical metal molds having nominal volumes of 0.100 ft³(2 830 cm³) and 0.500 ft³(14 200 cm³). The molds shall conform to the requirements shown in Fig. 2. The actual volume of the molds shall be within ±1.5 % of the specified nominal volume.

6.1.2 *Special Molds*—Cylindrical metal molds having a capacity less than 0.100 ft³(2 830 cm³), an inside diameter equal to or greater than 2¾ in. (70 mm), but less than 4 in. (100 mm) and conforming to the design methodology presented in Fig. 3. Such molds may only be used when the test results are to be used in conjunction with design or other special studies or both, and there is not enough soil to use the 0.100 ft³(2 830 cm³) mold.

6.1.3 *Guide Sleeves*—One guide sleeve with clamp assembly, or other suitable attachment devices [see Fig. 4(a)], for each size mold. For easy centering of the guide sleeve above the mold, two of the three setscrews on the clamp assembly should be provided with lock nuts.

6.1.4 *Surcharge Base Plates*—One surcharge base plate for each standard size mold, conforming to the requirements of Fig. 5.

6.1.5 *Surcharge Weights*—One surcharge weight for each size mold. See Fig. 5 for tolerances related to the 0.100 ft³(2 830 cm³) and 0.500 ft³(14 200 cm³) molds. For special molds, similar tolerances should be maintained. The total mass of the surcharge base plate and surcharge weight shall be equivalent to a surcharge stress of 2.00 ± 0.02 lb/in.²(13.8 ± 0.1 kPa) for the mold being used. For special molds, the surcharge weight can be composed of a single solid mass of metal.

6.1.6 *Surcharge Base-Plate Handle*—A device used to initially place and then to remove the surcharge base plate upon completion of densification. An example of such a handle is given in Fig. 4(b); however, any convenient hooking device may be used.

6.2 *Dial-Indicator Gage Holder and Dial Indicator*—A device used, in conjunction with the guide brackets, to measure the difference in elevation between the top surfaces of the mold and surcharge base plate after densification [Fig. 4(c)]. The dial indicator shall have a 2-in. (50-mm) or greater travel, with

⁶ E. T. Selig and R. S. Ladd, eds., *Evaluation of Relative Density and its Role in Geotechnical Projects Involving Cohesionless Soils*, ASTM STP 523, ASTM, 1973.

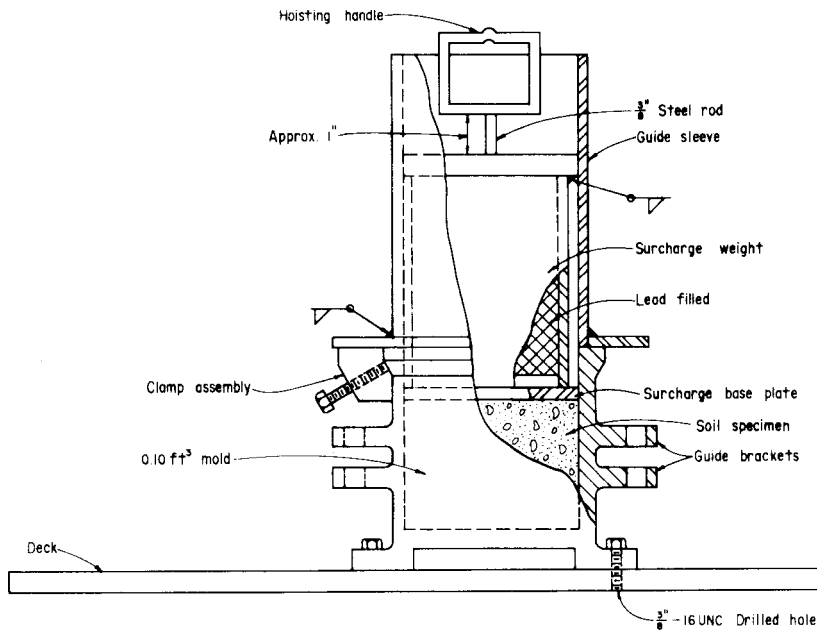

FIG. 1 Schematic Drawing of a Typical Mold Assembly

0.001-in. (0.025-mm) graduations and mounted so that the dial stem is parallel with the vertical axis of the mold. The dial indicator may be of the clockwise-movement type where the dial pointer reads zero when the stem is extended, or of the counterclockwise type where the dial pointer reads zero when the stem is all the way in.

6.3 *Balance(s)*, of sufficient capacity to determine the total mass of the specimen and mold, having sufficient accuracy that the mass of the soil is determined to the nearest 0.1 %. Examples of balances capable of satisfying these requirements for most conditions have specifications as follows:

6.3.1 For 0.500-ft³ (14 200-cm³) molds, use a balance having a minimum capacity of 40-kg and meeting the requirements of Specification D 4753 for Class GP 10 (readability of 5 g).

6.3.2 For 0.100-ft³ (2 830-cm³) molds, use a balance of at least 15-kg capacity and meeting the requirements of Specification D 4753 for Class GP 5 (readability of 1 g).

6.3.3 For special molds that are less than 0.1-ft³ (2 830-cm³), use a balance having a minimum capacity of at least 2-kg and meeting the requirements of Specification D 4753 for a Class GP 2 (readability of 0.1 g).

6.4 *Hoist*—A rope, chain, or cable hoist of at least 140-kg capacity when either the 0.100-ft³ (2 830-cm³) or 0.500-ft³ (14 200 cm³) size molds are being used.

6.5 *Drying Oven*, thermostatically controlled, preferably of the forced-draft type, capable of maintaining a uniform temperature of 110 ± 5°C throughout the drying chamber.

6.6 *Sieves*, 3-in. (75-mm), 1½-in. (37.5-mm), ¾-in. (19-mm), ⅜-in. (9.5-mm), No. 4 (4.75-mm), and No. 200 (75-µm) sieves conforming to the requirements of Specifications E 11.

6.7 *Calibration Bar*, metal, about 3 by 12 by ¼ in. (75 by 300 by 6 mm), optional (see 10.4).

6.8 Other equipment such as mixing pans, a large metal scoop, a hair-bristled dusting brush, a timing device indicating minutes and seconds, a micrometer with at least a 1-in. (25-mm) travel and with 0.001-in. (0.025-mm) graduations,

and a metal straight edge (for trimming excess soil after it has been placed in the mold, if the minimum index density/unit weight by Test Methods D 4254 is being determined).

6.9 *Vibrating Table*, shall be mounted to a concrete floor or mass of sufficient size and configuration that excess vibrations are not transmitted to other testing areas. The vertically vibrating deck of the table shall be of sufficient size and rigidity that the mold assembly being used can be attached and rigidly supported during the test. The table shall be capable of vertically vibrating the mold assembly with a sinusoid-like time-vertical displacement relationship at an average double amplitude (peak-to-peak displacement) of 0.013 ± 0.002 in. (0.33 ± 0.05 mm) at a frequency of 60 Hz or 0.019 ± 0.003 in. (0.48 ± 0.08 mm) at 50 Hz under test conditions. The table shall have the capability for adjustment of the frequency of vibration (between 0 to 60 Hz) or double amplitude of vibration, or both, between about 0.005 in. (0.15 mm) and 0.013 in. (0.33 mm) at 60 Hz or about 0.007 in. (0.20 mm) and 0.019 in. (0.48 mm) at 50 Hz for use with Methods 1A, 1B, 2A, or 2B (11.2.3). The table shall have the capability for adjustment of the double amplitude of vibration between about 0.008 in. (0.20 mm) and 0.025 in. (0.64 mm) at 60 Hz or about 0.012 in. (0.30 mm) and 0.036 in. (0.91 mm) at 50 Hz for use in conjunction with design or other special studies (11.1.6.3).

6.9.1 Use one of the following table types:

6.9.1.1 *Electromagnetic Vibrating Table*—A steel table conforming to the requirements of 6.9 with a vertically vibrating, cushioned steel deck generally about 30 by 30 in. (760 by 760 mm), actuated by an electromagnetic vibrator of the solid-impact type with a net mass over 45 kg. The table shall be mounted to a concrete floor or slab having a mass of about 450 kg.

6.9.1.2 *Eccentric or Cam-Driven Vibrating Table*, conforming to the requirements of 6.9. The mass required to support cam-driven tables and eliminate vibrations in other areas may be as large as 4500 kg.

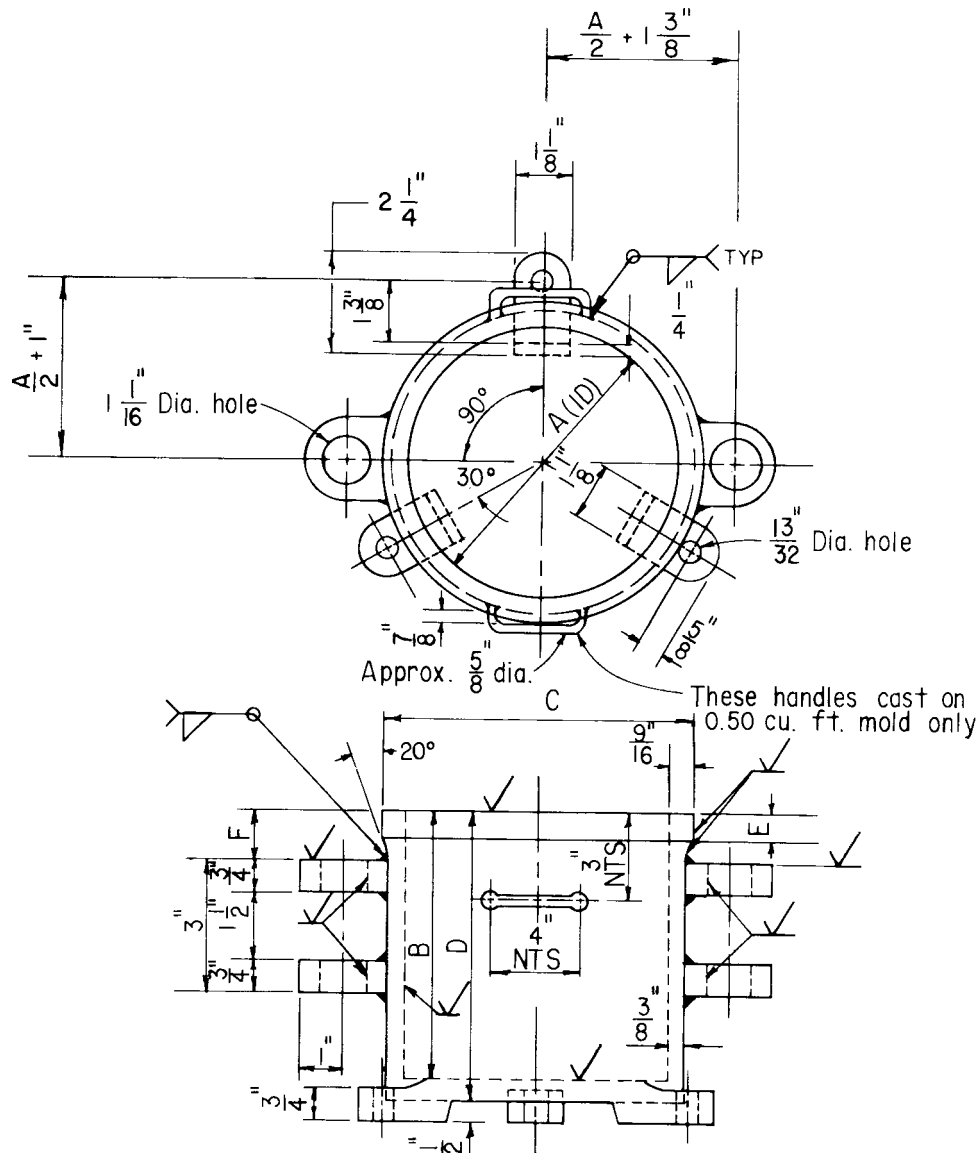

NOTE 1—Tolerances are $\pm\frac{1}{64}$ in. (± 0.4 mm) unless otherwise noted.

Size Mold ft ³ (cm ³)	Dimensions, in. (mm)					
	A ($+0.005$ in. -0.000)	B ($+0.005$ in. -0.000)	C	D	E	F
0.100 (2830)	6.000 (152.4)	6.112 (155.2)	7 $\frac{1}{8}$ (181.0)	6 $\frac{1}{2}$ (105.1)	$\frac{1}{2}$ (12.7)	1 $\frac{1}{8}$ (28.6)
0.500 (14 200)	11.000 (279.4)	9.092 (230.9)	12 $\frac{1}{8}$ (308.0)	9 $\frac{1}{2}$ (241.3)	$\frac{5}{8}$ (15.9)	2 (50.8)

FIG. 2 Details of Molds

NOTE 4—See Footnote 6 (not Note 6) for examples of electromagnetic and cam-driven vibratory tables.

7. Precautions

7.1 *Safety Precautions*—Use of vibratory tables in certain acoustic environments may produce noise levels above those considered acceptable. Suitable hearing-protection devices shall be used in areas where such conditions are known to exist or where acoustic monitoring surveys have not been conducted. In addition, testing personnel should also adhere to any additional personal safety requirements in accordance with individual laboratory policies.

8. Sampling and Test Specimen

8.1 Prior to testing, the sample should be stored in a manner to prevent freezing, contamination with other matter, loss of soil, or loss of identification.

8.2 The required size (mass) of the test specimen and mold is a function of the maximum particle size contained in the sample and the particle-size distribution (gradation) of the sample (see Table 1).

8.2.1 Using a visual method or Test Method D 422 (depending upon the complexity of the gradation of the sample and operator experience), determine the percentage of particles

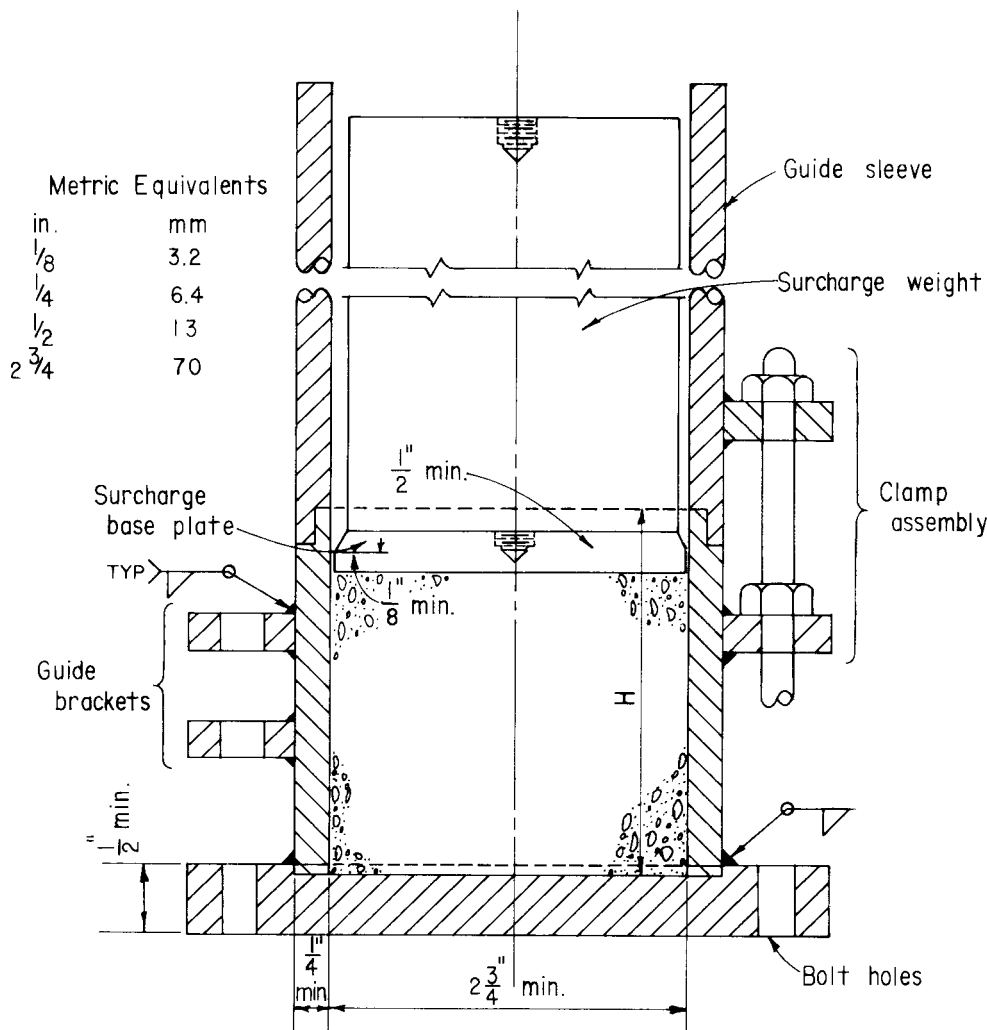

H = (0.7 to 1.3) times diameter
FIG. 3 Special Cylindrical Metal Molds

retained on the 3-in. (75-mm), 1½-in. (37.5-mm), ¾-in. (19.0 mm), ⅜-in. (9.5-mm), No. 4 (4.75-mm), and No. 200 (75-µm) sieves.

8.2.2 The determination of the maximum index density/unit weight should not be performed in accordance with these test methods unless the requirements of 1.5 are met. If these conditions are met, then the mold size and specimen mass required can be determined according to the maximum particle size as prescribed in Table 1.

8.2.3 When it is applicable to use special molds, 100 % of the sample shall pass the ¾-in. (19.0-mm) sieve and have less than 10 % retained on the ⅜-in. (9.5-mm) sieve.

8.2.3.1 The selected test specimen shall have a mass not less than that determined using the following equation:

$$M_r = 0.0024 \cdot V_m \quad (8)$$

where:

M_r = mass required in kg, and

V_m = volume of mold in cm³.

8.3 Select a representative specimen of soil that meets the requirements of 8.2, using a splitter, riffle, or other method such as quartering.

8.4 If Methods 1A or 2A are being performed, dry the specimen in the drying oven, maintained at 110 ± 5°C to a constant mass. It is often desirable to obtain the water content of the field sample. If this is the case, determine the water content in accordance with Test Method D 2216.

8.4.1 After drying, thoroughly break up the weakly cemented aggregations; avoiding the reduction of the natural size of the particles.

9. Preparation of Apparatus

9.1 For a mold assembly in which the alignment of the guide sleeve on top of the mold is controlled by the position of the setscrews, assemble the guide sleeve on top of the mold and tighten the clamp assemblies so that the inner wall of the sleeve is in line with the inner wall of the mold. Tighten the lock nuts on the two setscrews so equipped. Loosen the set screw having no lock nut and remove the guide sleeve.

9.2 Determine and record the mass of the empty mold, using the appropriate balance specified in 6.3.

9.3 Check that the vibrating table is in good working condition and that parts are not loose or worn. Make any necessary adjustments or repairs.

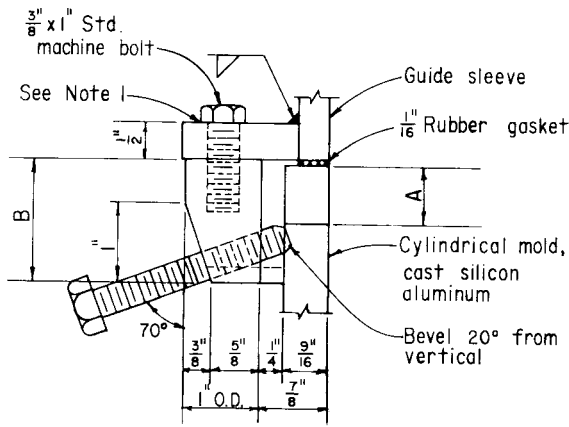

(a)
Typical Clamp Assembly for Guide Sleeve
for Guided Surcharge Weights.

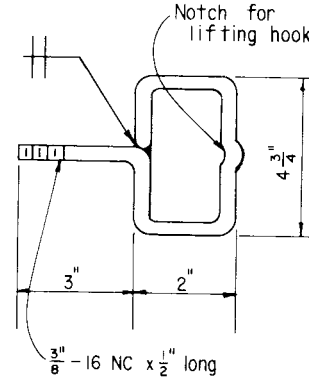

(b)
Surcharge Base Plate Handle
(1 Required)

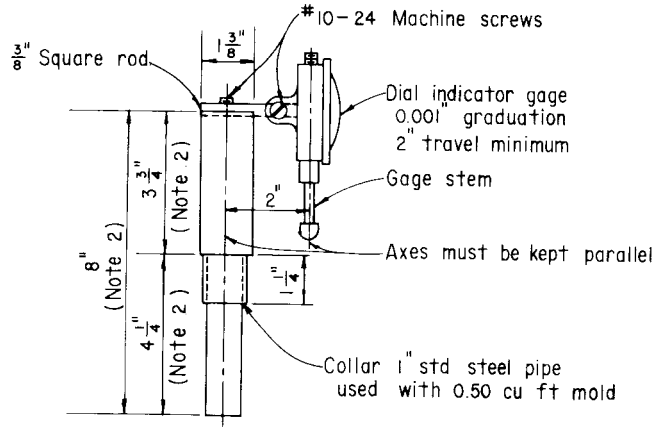

(c)
Holder for Dial Indicator Gage

NOTE 1—This piece shall be a steel bar, 1½ by ½ in. (38.1 by 12.7 mm) of a length necessary to produce the indicated dimension from the inside of the guide sleeve. Weld three clamp assemblies to the guide sleeve at equal spacing.

NOTE 2—These dimensions must be changed to fit the dial gage indicator used.

NOTE 3—Tolerances are ±¼ in. (±0.4 mm) unless otherwise noted.

Size Mold, ft ³ (cm ³)	A, in. (mm)	B, in. (mm)	Guide Sleeve
0.100 (2830cm ³)	½(12.7)	1¾ (34.9)	Steel tubing, 6 in. (150 mm) ID ¼ in. (6.4 mm) wall, 12 in. long (305 mm)
0.500(14 200cm ³)	¾ (15.9)	1½ (38.1)	Steel pipe, 11 in. (280 mm) ID ¾ in. (9.5 mm) wall, 8 in. (200 mm) long

FIG. 4 Details of Apparatus Components

9.4 Check that one set of initial dial readings is within ± 0.005 in. (0.15 mm) of the value obtained in 10.4, that is, the dial-gage zero has not been changed. As required, adjust the dial gage or reperform the calibration (10.4). Alternatively, a reference bracket [similar to that shown in Fig. 6] may be used and, if required, adjust the dial gage to the reference bracket reading.

10. Calibration

10.1 The following calibrations of test apparatus should be performed before initial use and at intervals not exceeding each 1000 tests, or annually, whichever occurs first.

10.2 *Molds*—Determine the volume of each mold by either the direct-measurement method or the water-filling method as

TABLE 1 Required Mass of Specimen^A

Maximum Particle Size (100 % Passing) in. (mm)	Mass of Specimen Required, (kg)	Size of Mold to be Used, ft ³ (cm ³)
3 (75)	34	0.500(14 200)
1½ (38.1)	34	0.500(14 200)
¾ (19.0)	11	0.100 (2830)
¾ (9.5)	11	0.100 (2830)
No. 4 (4.75) or less	11	0.100 (2830)

^A The mass of the sample should be at least two (preferably four) times these values, since normally the wet and dry method is performed and more than one trial is done in the dry method preferably using non-tested soil (see 11.1.11).

provided in 10.2.1 and 10.2.2. The volume obtained by either method should be within ±1.5 % of the nominal value. It is

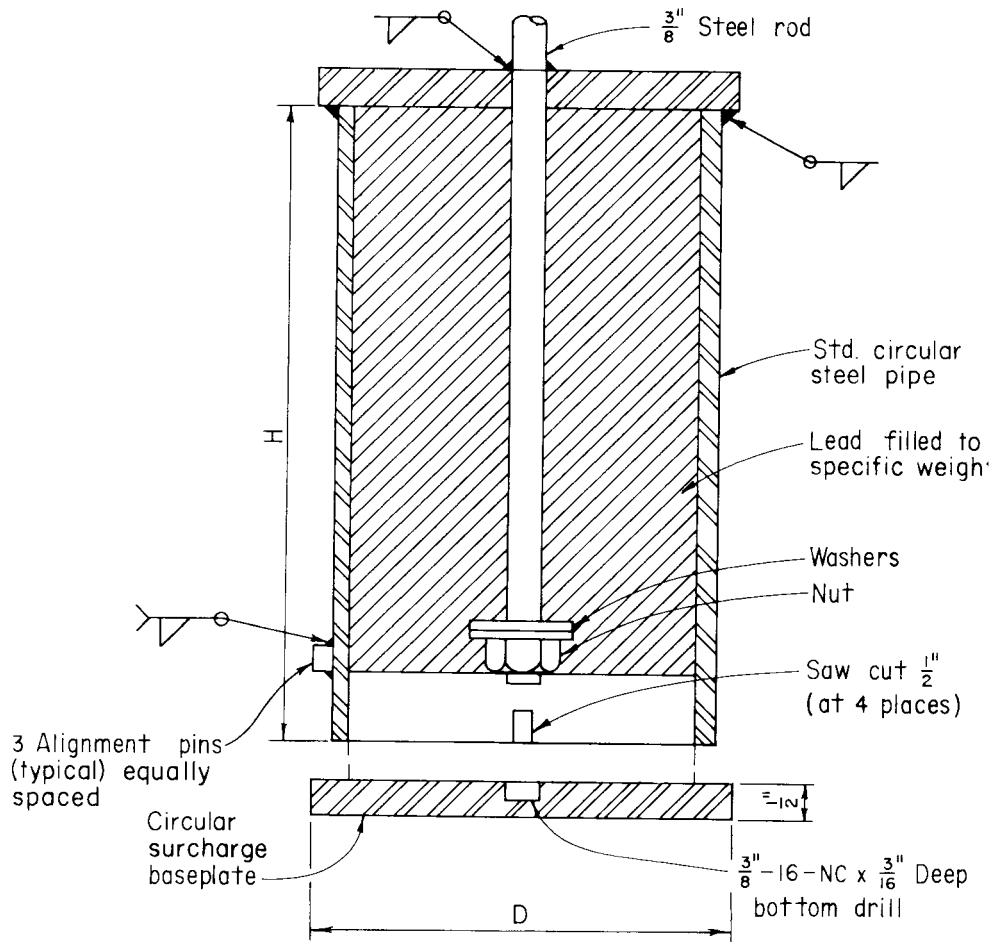

NOTE 1—All plates shall be 1/2-in. (12.7-mm) thick steel.

NOTE 2—Top plates for weights may be torch-cut, but edges must be ground as smooth as practicable. Surcharge base plates must be machined to the specified diameter.

NOTE 3—Hoisting handles shall have the same shape as the surcharge base plate handle (see Fig. 4 (b)).

Size Mold, ft ³ (cm ³)	D, in. (mm)	H, in. (mm)	Standard Pipe, in. (mm)	Total Weight Required, lb (kg)
0.100 (2830)	5 15/16 (151)	6.0 (150)	4.0 (100)	56.5 ± 0.5 (25.6 ± 0.2)
0.500(14 200)	10 7/8(276)	9.0 (230)	10 (250)	190 ± 2 (86.2 ± 0.9)

FIG. 5 Circular Surcharge Weight and Base Plate

recommended that both the direct-measurement and water-filling methods be used. If the difference between the volumes calculated from the two methods exceeds 0.5 % of the nominal value of the mold being calibrated, then the calibration should be repeated. Failure to obtain agreement between the two calibration methods within the stated tolerances, even after several trials, is an indication that the mold is badly deformed and should be replaced. If both calibration methods are performed, the volume obtained by the water-filling method should be assigned to the mold (as this method more accurately reflects the conditions over the entire mold).

10.2.1 *Direct Measurement Method*—The volume of the mold is calculated from the average of at least three internal diameter and three height measurements, evenly spaced throughout the mold, made to the nearest 0.001 in. (0.025 mm). Calculate and record the height, in m or cm to four significant digits (in accordance with Practice D 6026). Calculate and

record the cross-sectional area, A_m , (m² or cm²) and volume, V_m , (m³ or cm³) to four significant digits (in accordance with Practice D 6026).

10.2.2 *Water-Filling Method*—Completely fill the mold with water. Slide a glass plate carefully over the top surface (rim) of the mold to ensure that the mold is completely filled with water. A thin film of grease or silicone lubricant on the rim of the mold will make a watertight joint between the glass plate and rim of the mold. Determine the mass of the water required to fill the mold using the appropriate balance specified in 6.3.3. Determine the temperature of this water to the nearest degree Celsius. From Table 2, obtain the unit volume of water in milliliters per gram at the observed temperature. Calculate and record the volume of the mold (m³ or cm³) to four significant digits as follows:

10.2.2.1 For mass measurements in grams, the calculated volume in cubic centimeters (cm³) is obtained by multiplying

ASME D 4253

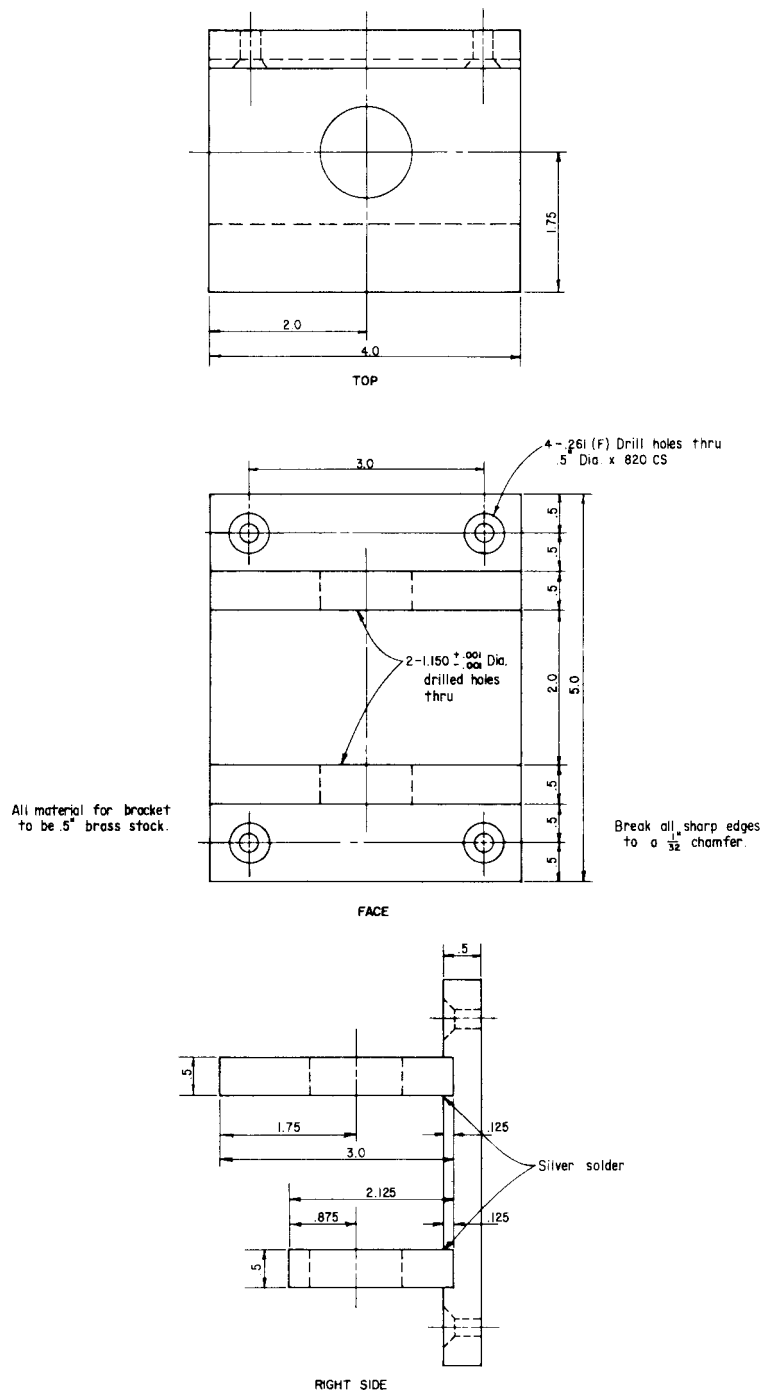

FIG. 6 Dial Gauge Calibration Standard (Reference Bracket)

the mass of water, in grams, used to fill the mold by the volume of water per gram (mL/g), from Table 2. To determine the volume in cubic meters (m^3), multiply the volume in cm^3 by 1×10^{-6} .

10.2.2.2 If only the water-filling method is used to determine the volume of the mold, then the cross-sectional area of the mold must be calculated by dividing its measured volume (10.2.2) by its measured height (10.2.1).

10.3 *Surcharge Base Plate*—Calculate and record the average thickness of the surcharge base plate (T_p) to the nearest 0.001 in. (0.025 mm) from at least four measurements using a

vernier or micrometer caliper. Calculate and record this thickness, T_p in same units that dial gage is recorded.

10.4 *Initial Dial Reading*—This value may be obtained using the calibration bar, as provided in 10.4.1 or without the bar, as provided in 10.4.2, if the contact area between the mold guide bracket and the collar of the dial gage holder (Fig. 2 and Fig. 4) has been machined level or made level by the use of brass inserts.

10.4.1 *Initial Dial Reading with Calibration Bar*—Determine the thickness of the calibration bar to 0.001 in. (0.025 mm) using a micrometer. Place the calibration bar

TABLE 2 Volume of Water per Gram Based on Temperature^A

Temperature		Volume of Water per Gram
°C	°F	mL/g
15	59.0	1.00090
16	60.8	1.00106
17	62.6	1.00122
18	64.4	1.00140
19	66.2	1.00129
20	68.0	1.00180
21	69.8	1.00201
22	71.6	1.00223
23	73.4	1.00246
24	75.2	1.00271
25	77.0	1.00296
26	78.8	1.00322
27	80.6	1.00350
28	82.4	1.00378
29	84.2	1.00407
30	86.0	1.00437

^A Values other than shown may be obtained by referring to the *CRC Handbook of Chemistry and Physics*. David R. Lide, Editor-in-Chief, 74th Edition, 1993–1994

across the diameter of the mold and between the vertical axis of the guide brackets. Insert the dial-indicator gage holder in each of the guide brackets on the mold with the dial gage stem on top of the calibration bar and its vertical axis in line with the vertical axis of the opposite guide bracket. The dial gage holder should be placed in the same position in the guide brackets each time by means of matchmarks on the guide brackets and the holder. Obtain six dial indicator readings, three on each the left and the right sides, and average these six readings. To compute the initial dial reading, R_i , for clockwise-reading dial indicators, subtract the thickness of the calibration bar from the average of the six dial indicator readings. To compute counterclockwise-reading dial indicators, R_i , add the thickness of the calibration bar to the average of the six dial indicator readings. Record R_i to the nearest 0.001 in. (0.025 mm).

10.4.2 Initial Dial Reading Without Calibration Bar—Insert the dial indicator gage holder in each of the guide brackets with the dial gage stem in contact with the rim of the mold (at its center) on both sides of the guide brackets. Obtain six sets of dial indicator readings, three on each side of each guide bracket. The average of these twelve readings is the initial dial gage reading, R_i . Record R_i to the nearest 0.001 in. (0.025 mm).

10.5 Vibrating Table—The calibration shall consist of determining, under simulated test conditions and for each mold size being used, the required rheostat, eccentric, or cam setting for the electro-magnetic, eccentric, or cam-driven table, respectively, such that the mold has a double amplitude of vertical vibration of 0.013 ± 0.002 in. (0.33 ± 0.05 mm) at 60 Hz or 0.019 ± 0.003 in. (0.48 ± 0.08 mm) at 50 Hz. The double amplitude of vibration should be measured on the mold to the nearest 0.0005 in. (0.015 mm). It is recommended that during each calibration a relationship between the double amplitude of vertical vibration versus the rheostat, eccentric, or cam setting be established.

10.5.1 While there are many different equipment configurations that can be used to measure this double amplitude of vibration, it is not easily measured unless one has considerable experience. Typical calibration procedure and equipment re-

quirements have been given in the *Geotechnical Testing Journal*.⁷

10.5.2 In addition to the calibration frequency recommended in 10.1, the vibrating table should also be calibrated before reuse after any event (including repairs) which might affect its operation and whenever the test results are questionable.

11. Procedure

11.1 Dry Method—Methods 1A or 2A:

11.1.1 Mix the oven-dried specimen to provide an even distribution of particle sizes; that is, having as little segregation as possible.

11.1.2 Fill the mold with soil and level the surface of the soil using methods that minimize segregation (see Note 5). A scoop or pouring device (funnel) should be used to place the soil in the mold. The sides of the mold may be struck a few times using a metal bar, rubber hammer, or similar item to settle the soil so that the surcharge base plate can be easily placed into position and there is no surge of air from the mold when vibration is initiated.

NOTE 5—If the minimum index density/unit weight is also being performed, the soil shall be placed in accordance with the appropriate method specified in Test Methods D 4254. The mass of the mold plus soil shall also be determined and recorded.

11.1.3 Place the appropriate surcharge base plate on the surface of the soil and twist it slightly several times so that it is firmly and uniformly in contact with the surface of the soil. Remove the surcharge base-plate handle.

11.1.4 Attach the mold to the vibrating table.

11.1.5 Firmly attach the guide sleeve to the mold and lower the appropriate surcharge weight onto the surcharge base plate.

11.1.6 Setting for double amplitude of vibration.

11.1.6.1 Method 1A—Set the vibrator control (rheostat) at the setting determined in 10.5 for the mold assembly being used to obtain a double amplitude of vertical vibration of 0.013 ± 0.002 in. (0.33 ± 0.05 mm) at 60 Hz or 0.019 ± 0.003 in. (0.48 ± 0.08 mm) at 50 Hz.

11.1.6.2 Method 2A—Set the eccentric or cam at the setting determined in 10.5 for the mold assembly being used to obtain a double amplitude of vertical vibration of 0.013 ± 0.002 in. (0.33 ± 0.05 mm) at 60 Hz or 0.019 ± 0.003 in. (0.48 ± 0.08 mm) at 50 Hz.

11.1.6.3 As stated in 5.4, there is a relationship between density/unit weight and double amplitude of vibration, and the peak density/unit weight occurs at an optimum double amplitude of vibration which may not be the same as the maximum index density/unit weight obtained at the double amplitude of vibration prescribed in 11.1.6.1 and 11.1.6.2. Therefore, this method allows the use of a double amplitude of vertical vibration other than those prescribed in 11.1.6.1 or 11.1.6.2 if the following conditions are met:

(a) (a) Test results are to be used in conjunction with design or special studies or both, and

⁷ Kaufman, L. P., Strickland, E. A., and Benavidez, A. A., "Suggested Method for the Calibration of Vibrating Tables for Maximum Index Density Testing," *Geotechnical Testing Journal*, GTJODJ, Vol 2, No. 3, Sept. 1979, pp. 152–157.

(b) (b) The double amplitude of vertical vibration used should be: (a) the optimum double amplitude of vertical vibration (see the Appendix X1 for a recommended method to obtain the optimum double amplitude of vibration), (b) less than 0.025 in. (0.64 mm) at 60 Hz or 0.037 in. (0.94 mm) at 50 Hz, and (c) greater than 0.008 in. (0.20 mm) at 60 Hz or 0.012 in. (0.30 mm) at 50 Hz (except when filling the mold for the wet method, 11.2.3). In terms of nominal peak acceleration, these values are greater than about 1.5 g (14 m/s²) and less than about 4.8 g (45 m/s²).

NOTE 6—The nominal peak acceleration can be calculated using the following equation:

$$A_p = 0.0511 \cdot (2Y_p) \cdot f^2 \quad (9)$$

where:

A_p = nominal peak acceleration in g,
 $2Y_p$ = double amplitude of vertical vibration in inches, and
 f = frequency in cycles per second, Hz.

11.1.7 Vibrate the mold assembly and specimen for $8 \pm \frac{1}{4}$ min at 60 ± 2 Hz or for $12 \pm \frac{1}{4}$ min at 50 ± 2 Hz. Remove the surcharge weight and guide sleeve from the mold. Check that the surcharge base plate is firmly and uniformly in contact with the surface of the soil; that is, does not wobble when pressed at the edges. If it wobbles, this should be noted on the report form (data sheet).

11.1.8 To obtain and record dial indicator gage readings on opposite sides of the surcharge base plate, place the indicator gage holder in each of the guide brackets. Brush aside any fines that might have collected on the surcharge base plate where these readings will be taken.

11.1.9 Remove the surcharge base plate from the mold and detach the mold from the vibratory table. During this step, prevent (as much as possible) any fines that have collected on the surfaces of the surcharge base plate and the rim of the mold from entering the mold. If the mass of these fines is greater than about 0.2 % of the total mass of the specimen, determine the mass and note it on the report form (data sheet).

11.1.10 Determine and record the mass of the mold and soil using a balance meeting the requirements of 6.3. To calculate and record the mass of the soil filling the mold, subtract the mass of the empty mold from the mass of the mold and soil. Alternately, the contents of the mold may be emptied into a pan and weighed. Calculate the maximum-index density/unit weight, $\rho_{dmax,n}$, in accordance with Section 12.

11.1.11 Steps 11.1.1-11.1.10 should be repeated until consistent values of maximum index density/unit weight (preferably within 2 %) are obtained. If excessive degradation (particle breakdown) of the soil is suspected, a sufficient quantity of representative soil sample should be provided (if possible), so that a single test specimen is not repeatedly subjected to step 11.1.7.

11.2 Wet Method—Methods 1B or 2B:

11.2.1 The wet method may be conducted on either oven-dried soil to which sufficient water is added or, if preferred, on wet soil from the field. Mix the sample to provide an even distribution of particle sizes and water content with as little segregation as possible. If water is added to dry soil, allow a

minimum soaking period of about $\frac{1}{2}$ h. The amount of water added should be sufficient enough that free water does not accumulate in the mixing pan, and the specimen will become basically saturated during the densification process.

NOTE 7—The following equation can be used to estimate the amount of water required to be added to an oven-dried soil or, initially, try about 1000 mL for every 4.5 kg of dry soil.

$$M_w = M_s \cdot \left(\frac{\rho_w - 1}{\rho_d - G_s} \right) \quad (10)$$

where:

M_w = mass of water in grams,
 ρ_d = estimated dry density after initial placement in mold in Mg/m³. This typically ranges between 1.6 and 1.9 Mg/m³.
 M_s = mass of test specimen in grams,
 ρ_w = density of water, 1 Mg/m³, and
 G_s = specific gravity of soil solids.

11.2.2 Attach the mold to the vibrating table.

11.2.3 With the vibrating table turned on, slowly fill the mold with wet soil using a scoop or shovel. After each increment of soil is added, inspect to see if a small amount of free water has accumulated on the soil surface. If not, add a sufficient amount of water by squeezing from a sponge, pouring from a small container, or by other means. During this process, which is to take 5 to 6 minutes, the double amplitude or the frequency or both, of vibration must be adjusted to prevent excessive boiling and fluffing of the soil. During and just after the final minute of vibration, any water appearing above the surface of the soil should be removed using means which prevent, as much as possible, the removal of soil.

11.2.4 Assemble the surcharge base plate, surcharge weight, and guide sleeve as specified in 11.1.3 and 11.1.5.

11.2.5 Vibrate the mold assembly and specimen as specified in 11.1.6-11.1.7. After the vibration period, remove the surcharge weight and guide sleeve from the mold. Remove any free water appearing above, on, and around the surcharge base plate.

11.2.6 Obtain and record dial indicator-gage readings in accordance with 11.1.8.

11.2.7 Remove the surcharge base plate and detach the mold from the vibratory table in accordance with 11.1.9. If a determination of the specimen water content is desired, determine and record the mass of the mold and soil. Carefully remove the entire wet specimen from the mold, placing it in a pan of known mass for oven drying. Wash all particles clinging to the inside of the mold and bottom of the base plate into the pan. Dry the specimen in a drying oven, maintained at $110 \pm 5^\circ\text{C}$ to a constant mass (Test Method D 2216). Determine and record its oven-dried mass, using a balance meeting the requirements of 6.3.

12. Calculation

12.1 Calculate the maximum index density for each trial (see 11.1.11) as follows:

$$\rho_{dmax,n} = \frac{M_s}{V} \quad (11)$$

where:

- $\rho_{dmax,n}$ = maximum index density for given trial, Mg/m³ or g/cm³
 M_s = mass of the tested-dry soil, Mg or g, and
 V = volume of the tested-dry soil, m³ or cm³, being equal to:

$$V = V_c - (A_c \cdot H \cdot \text{Conversion Factor}) \quad (12)$$

with: Conversion Factor given in Table 3; and

- V_c = calibrated volume of mold, m³ or cm³,
 A_c = calibrated cross sectional area of mold, m² or cm², and
 H = positive difference in elevation between top surfaces of mold and tested soil (botto surface of surcharge base plate), m or cm, being equal to:

$$H = R_f - R_i + T_p \text{ for clockwise-reading dial indicator, or} \quad (13)$$

$$H = R_i - R_f + T_p \text{ for counterclockwise-reading dial indicator.}$$

with:

- R_i = initial dial reading (see 10.4), mm or in.,
 R_f = average of final dial gage readings on opposite sides of the surcharge base plate after completion of the vibration period, mm or in., and
 T_p = thickness of surcharge base plate, mm or in.

12.1.1 Calculate the average maximum-index density/unit weight from the trials of the dry method that agree within 2 %, see 11.1.11. This average value is to recorded/reported as the maximum-index density, ρ_{dmax} .

12.1.1.1 If it is established that the wet method produces a maximum-index density/unit weight higher than the dry method and this higher value would significantly affect its application, then the result of the wet method should be used.

12.1.2 If requested, calculate the maximum-index unit weight of the specimen as follows:

$$\gamma_{dmax} = 9.807 \cdot \rho_{dmax}, \text{ kN/m}^3, \text{ or} \quad (14)$$

$$\gamma_{dmax} = 62.428 \cdot \rho_{dmax}, \text{ lbf/ft}^3$$

where:

- γ_{dmax} = maximum-index unit weight, kN/m³ or lbf/ft³
 9.807 = conversion factor, Mg/m³ or g/cm³ to kN/m³, and
 62.428 = conversion factor, Mg/m³ or g/cm³ to lbf/ft³.

NOTE 8— ρ_{dmax} is the average value if Method 1A or 2A is used, see 12.1.1.

12.2 If requested, calculate the minimum-index void ratio, e_{min} , as follows:

$$e_{min} = \frac{\rho_w \cdot G_{avg}}{\rho_{dmax}} - 1 \quad (15)$$

TABLE 3 Dial Reading Conversion Factors for Volume Calculations

Volume Requirements	Factor	
	Dial Reading Units	
	mm	in.
m ³	0.001	0.0254
cm ³	0.1	0.2540

where:

- e_{min} = minimum-index void ratio,
 ρ_w = density of water at 20°C (0.99821) or equal to 1 Mg/m³ or g/cm³,
 ρ_{dmax} = maximum-index density, Mg/m³ or g/cm³, and
 $G_{avg@20^\circ C}$ = weighted average specific gravity of soil solids composed of particles larger and smaller than the No. 4 (4.75-mm) sieve being equal to:

$$G_{avg@20^\circ C} = \frac{1}{\frac{R}{100G_{1@20^\circ C}} + \frac{P}{100G_{2@20^\circ C}}} \quad (16)$$

with:

- $G_{1@20^\circ C}$ = apparent specific gravity of the soil solids retained on the No. 4 sieve as determined by Test Method C 127 and corrected to 20°C (see Test Methods D 854),
 $G_{2@20^\circ C}$ = specific gravity of the soil solids passing the No. 4 sieve as determined by Test Methods D 854,
 R = percentage of soil particles retained on the No. 4 sieve, and
 P = percentage of soil particles passing the No. 4 sieve.

12.3 If the minimum index density/unit weight, ρ_{dmin} or γ_{dmin} , has been determined in accordance with Test Methods D 4254; and the soil deposit or fill dry density/unit weight, ρ_d or γ_d , or void ratio, e , is known, the relative density, D_r , can be calculated by any of the equations given in 3.2.7, i.e., Equations 1, 2, or 3.

13. Report

13.1 The report shall include the following information:

13.1.1 Origin of material used in test.

13.1.2 Description of appearance of test specimen, based on Practice D 2488 (Practice D 2487 may be used as an alternative).

13.1.3 The Methods (1A, 1B, 2A, or 2B) and size of mold used.

13.1.4 Double amplitude of vertical vibration used if different from that specified in 11.1.6.1 or 11.1.6.2.

13.1.5 The maximum index density, ρ_{dmax} , Mg/m³ or g/cm³ or maximum-index unit weight, γ_{dmax} in lbf/ft³(kN/m³), or both, to four significant digits (in accordance with Practice D 6026).

13.1.6 Any abnormalities such as loss of material, segregation, or excessive tilt of base plate.

14. Precision and Bias

14.1 *Precision*—Criteria for judging the acceptability of test results obtained by these test methods, using Method 1A and testing a poorly graded sand (SP), is given in Tables 4 and 5. These estimates of precision are based on the results of the interlaboratory program conducted by the ASTM Reference

TABLE 4 Summary of Test Results from Triplicate Test Laboratories (Maximum Index Unit Weight)

(1) Soil Type	(2) Number of Triplicate Test Labs	(3) Average Value ^A (lb/ft ³)	(4) Standard Deviation ^B (lb/ft ³)	(5) Acceptable Range of Two Results ^C (lb/ft ³)
<i>Single-Operator Results (Within-Laboratory Repeatability):</i>				
SP	8	117.3	0.6	1.5
<i>Multilaboratory Results (Between-Laboratory Reproducibility):</i>				
SP	8	117.3	1.0	2.7

^AThe number of significant digits and decimal places presented are representative of the input data. In accordance with Practice D 6026, the standard deviation and acceptable range of results can not have more decimal places than the input data.

^BStandard deviation is calculated in accordance with Practice E 691 and is referred to as the 1s limit.

^CAcceptable range of two results is referred to as the d2s limit. It is calculated as $1.960 \sqrt{2} \cdot 1s$, as defined by Practice E 177. The difference between two properly conducted tests should not exceed this limit. The number of significant digits/decimal places presented is equal to that prescribed by these test methods or Practice D 6026. In addition, the value presented can have the same number of decimal places as the standard deviation, even if that result has more significant digits than the standard deviation.

TABLE 5 Summary of Single Test Result from Each Laboratory (Maximum Index Unit Weight)^A

(1) Soil Type	(2) Number of Test Labs	(3) Average Value (lb/ft ³)	(4) Standard Deviation (lb/ft ³)	(5) Acceptable Range of Two Results (lb/ft ³)
<i>Multilaboratory Results—Reproducibility (Single Test Performed by Each Laboratory):</i>				
SP	12	116.9	1.8	5.1

^ASee footnotes in Table 4.

Soils and Testing Program.⁸ In this program, some laboratories performed three replicate tests per soil type (triplicate test laboratory), while other laboratories performed a single test per soil type (single-test laboratory). A description of the soil tested is given in 14.1.4. The precision estimates may vary with soil type and method used (Method 1A, 1B, 2A, 2B). Judgement is required when applying these estimates to another soil or method.

⁸ Supporting data are available from ASTM Headquarters. Request RR:D18-1011.

14.1.1 The data in Table 4 are based on three replicate tests performed by each triplicate test laboratory on the SP sand. The single operator and multilaboratory standard deviation shown in Table 4, Column 4 were obtained in accordance with Practice E 691, which recommends each testing laboratory perform a minimum of three replicate tests. Results of two properly conducted tests performed by the same operator on the same material, using the same equipment, and in the shortest practical period of time should not differ by more than the single-operator d2s limits shown in Table 4, Column 5. For definition of d2s see Footnote C in Table 4. Results of two properly conducted tests performed by different operators and on different days should not differ by more than the multilaboratory d2s limits shown in Table 4, Column 5.

14.1.2 In the ASTM Reference Soils and Testing Program, many of the laboratories performed only a single test. This is common practice in the design and construction industry. The data in Table 5 are based upon the first test results from the triplicate test laboratories and the single test results from the other laboratories. Results of two properly conducted tests performed by two different laboratories with different operators using different equipment and on different days should not vary by more than the d2s limits shown in Table 5, Column 5. The results in Tables 4 and 5 are dissimilar because the data sets are different.

14.1.3 Table 4 presents a rigorous interpretation of triplicate test data in accordance with Practice E 691 from pre-qualified laboratories. Table 5 is derived from test data that represents common practice.

14.1.4 *Soil Type*—Based on the multilaboratory test results, the soil used in the program is described below in accordance with Practice D 2487. In addition, the local name of the soil is given.

SP—Poorly graded sand, SP, 20 % coarse sand, 48 % medium sand, 30 % fine sand, 2 % fines, yellowish brown. Local name—Frederick sand.

14.2 *Bias*—There is no accepted reference value for these test methods, therefore, bias cannot be determined.

15. Keywords

15.1 maximum index density; maximum index unit weight; relative density; vibrating table

APPENDIX

(Nonmandatory Information)

X1. RECOMMENDED METHOD TO OBTAIN THE OPTIMUM DOUBLE AMPLITUDE OF VIBRATION

X1.1 To reduce testing problems, the dry method (Test Method A) should be used. The size of mold used should be in accordance with 8.2.

X1.2 For the mold size and vibrating table being used, establish the relationship between the double amplitude of vertical vibration of the mold assembly, and the rheostat, eccentric, or cam setting under simulated test conditions.

X1.3 Select between four and six test specimens from the

sample using a splitter, riffle, or other method, such as quartering, and dry each specimen. An unused portion of material shall be used for each trial to eliminate any cumulative degradation effects of the soil.

X1.4 Using the procedure outlined in Section 11 (except for 11.1.6) perform about four trials with the double amplitude of vibration varying between about 0.008 in. (0.2 mm) and 0.025 in. (0.64 mm) for 60 Hz. See Table X1.1 for a typical set of

TABLE X1.1 Typical Set of Double Amplitude of Vibration Values

Frequency of Vibration	Double Amplitude of Vibration, in. (mm)					
50 Hz	0.012 (0.30)	0.017 (0.43)	0.022 (0.56)	0.026 ^A (0.66)	0.030 ^A (0.76)	0.036 ^A (0.91)
60 Hz	0.008 (0.20)	0.012 (0.30)	0.015 (0.38)	0.018 (0.46)	0.021 (0.53)	0.025 ^A (0.64)

^A For some electromagnetic tables, double amplitudes of vibration of 0.025 in. (0.64 mm) and above may be harmful to the electromagnets. This can be checked by inserting a strip of paper between the electromagnets in accordance with the manufacturer's instructions.

double amplitude of vibration values which may be used. If a peak dry density/unit weight is not clearly defined (see X1.5) then additional trials using other values as indicated in Table X1.1 or between those already tried shall be used.

X1.5 From the data obtained in X1.4, plot the dry density/unit weight values as ordinates with corresponding double amplitude of vibration values as abscissas. Draw a smooth curve connecting the plotted points. The double amplitude of vibration corresponding to the peak of this curve is termed the optimum double amplitude of vibration, while the peak dry

density/unit weight is termed the optimum maximum-index density/unit weight.

X1.6 For soils susceptible to degradation, the optimum maximum-index density/unit weight may not be clearly defined, that is, dry density/unit weight may continue to increase with increasing double amplitude of vibration beyond a reasonable value of 0.025 in. (0.64 mm) at 60 Hz or 0.037 in. (0.93 mm) at 50 Hz. For this case, a selected optimum double amplitude value of 0.015 in. (0.38 mm) at 60 Hz or 0.022 in. (0.56 mm) at 50 Hz shall be used.

SUMMARY OF CHANGES

In accordance with Committee D18 policy, this section identifies the location of changes to this standard since the last edition (93(Reapproved 1996)) that may impact its use.

- (1) The Summary of Changes section was added
- (2) "Test Methods" was changed to "Methods" where applicable.
- (3) Reworded sentences in 1.1 and 1.2.3.
- (4) Note 1 was reworded.
- (5) Under Terminology, changed order in which some terms are presented and corrected some equations so the resultant is in percent.
- (6) References to Practice E 380 were replaced with references to Practice D 6026. Also, references to Practices D 3740, D 6026, E 177, E 691, and Test Method D 1140 were made where applicable.
- (7) Note 3 was added (and all subsequent notes were renumbered) in accordance with D18 policy.
- (8) In 6.3.1-6.3.3 under balances gave the required readability for the specified balance.
- (9) Under Calibration in 10.2.2, reworded how the mass of water is to be determined (use appropriate balance specified in Apparatus Section). In 10.2.2.1, reworded and added sentence covering how to determine the volume in m³.
- (10) The mL/g constants in Table 2 were updated to agree with the density of water given in Test Methods D 854. Also, values

at one °C intervals were included and the reference was changed to agree with Test Methods D 854.

(11) In 10.4.1, the determination of the "initial dial reading" was reworded.

(12) In 12.1, reworded to indicate the density being calculated was for each trial, not the final result. In addition, the definition for "H" was added and the equation for "H" using clockwise-reading dial indicator was corrected.

(13) In 12.1.1-12.2 the sequence of calculations were modified, and many of the definitions for terms used in equations were reworded to maintain consistency and agreement with Test Methods D 854.

(14) In 12.3, the second equations was corrected so the result is in percent.

(15) The constants in Table 3 were corrected.

(16) In 13.1.5, the reporting requirement for density or unit weight was changed from "three" to "four" significant digits.

(17) In Table 1, the title for maximum particle size was modified to agree with that given in Test Methods D 1140.

(18) Section 14 on Precision and Bias was revised completely.

The American Society for Testing and Materials takes no position respecting the validity of any patent rights asserted in connection with any item mentioned in this standard. Users of this standard are expressly advised that determination of the validity of any such patent rights, and the risk of infringement of such rights, are entirely their own responsibility.

This standard is subject to revision at any time by the responsible technical committee and must be reviewed every five years and if not revised, either reapproved or withdrawn. Your comments are invited either for revision of this standard or for additional standards and should be addressed to ASTM Headquarters. Your comments will receive careful consideration at a meeting of the responsible technical committee, which you may attend. If you feel that your comments have not received a fair hearing you should make your views known to the ASTM Committee on Standards, at the address shown below.

This standard is copyrighted by ASTM, 100 Barr Harbor Drive, PO Box C700, West Conshohocken, PA 19428-2959, United States. Individual reprints (single or multiple copies) of this standard may be obtained by contacting ASTM at the above address or at 610-832-9585 (phone), 610-832-9555 (fax), or service@astm.org (e-mail); or through the ASTM website (www.astm.org).