



Standard Test Method for Laboratory Preparation of Chemically Grouted Soil Specimens for Obtaining Design Strength Parameters¹

This standard is issued under the fixed designation D 4320; the number immediately following the designation indicates the year of original adoption or, in the case of revision, the year of last revision. A number in parentheses indicates the year of last reapproval. A superscript epsilon (ϵ) indicates an editorial change since the last revision or reapproval.

1. Scope

1.1 This test method covers the laboratory preparation of chemically grouted soil specimens for use in laboratory tests to determine design strength parameters.

NOTE 1—This test method may not be applicable to grout mixtures with gel times shorter than the time required to saturate the specimen with grout.

1.2 The specimens are intended for both strength and modulus determination in unconfined and confined compression testing.

NOTE 2—Preparation methods for specimens to be used for other purposes are described in Test Methods D 4219 and D 5202.

1.3 This test method requires the injection of grout into soil specimens already fabricated to a desired density.

1.4 The values stated in inch-pound units are to be regarded as the standard.

1.5 *This standard does not purport to address all of the safety problems, if any, associated with its use. It is the responsibility of the user of this standard to establish appropriate safety and health practices and determine the applicability of regulatory limitations prior to use.*

2. Referenced Documents

2.1 ASTM Standards:

D 4219 Test Method for Unconfined Compressive Strength Index Test of Chemical-Grouted Soils²

D 5202 Test Method for Determining Triaxial Compression Creep Strength of Chemical Grouted Soils²

3. Significance and Use

3.1 The purpose of this test method is to prepare specimens of chemically grouted soils for testing in unconfined or triaxial compression, when the test data is to be used for design purposes.

4. Apparatus

4.1 *Specimen Molds*—Molds are to be constructed so that they may be longitudinally split to allow the removal of

grouted specimens without the use of a jacking force. They may be sized for the preparation of one or multiple specimens (Multiple specimen molds should be externally marked to indicate desired ends of individual specimens, as an aid in preparation). Molds shall produce specimens with a length-to-diameter ratio between two and three, (2.5 is recommended) and shall have a tolerance of ± 0.01 in. (0.25 mm) on the internal diameter. Molds will have top and bottom caps designed to prevent leakage of grout during pressure injection.

NOTE 3—Satisfactory molds, similar to Fig. 1, may be made from an acrylic tube which has been split longitudinally into three pieces (Fig. 2), which allows for the mold to be assembled and disassembled using silicon rubber seals and hose clamps. Equally satisfactory molds can be made by splitting tubes longitudinally with one narrow slit (Fig. 3), which is closed by hose clamps around the tubes and will reopen when the clamps are loosened, thus releasing the specimens. Leakage may be prevented by covering the slit from the inside with tape. Satisfactory seals of end caps may be made by threading the tubing and cap or by external tie rods to hold the caps in place (Fig. 4).

4.2 *Grout Injection System*—A system composed of the following components (Fig. 5):

4.2.1 *Mixing Tank*, capable of being pressurized to 30 psi (207 kPa) without leaking and able to contain all of the grout volume to be injected in one grouting operation. The tank will have an internal mixing device (such as a paddle wheel) or be able to accommodate the use of a magnetic stirrer. The tank will be fitted with a regulated air-pressure source and pressure gage.

NOTE 4—Alternatively, proportioning pump sets may be used. Such equipment may be of advantage when the grout gel times are too short for effective use of pressure-tank injection equipment.

4.2.2 *Tubing*, capable of transporting the grout from the mixing tank to the specimen mold or molds to be injected is required. A bleed valve located just before the mold injection inlet allows for air bubbles trapped in the grout lines to be removed before they move into the specimen.

4.3 *Balance*—A balance or scale of 1000-g capacity, sensitive to 0.1 g.

4.4 *Miscellaneous Equipment*—Tools such as: spoons, weighing dishes, etc., for handling and weighing soil and any dry grout components, graduate for measuring water and fluid grout components, tamping rod or vibrating tool or both for compaction of specimens to desired density, nylon screen having openings small enough to retain the soil to be grouted

¹ This test method is under the jurisdiction of ASTM Committee D-18 on Soil and Rock and is the direct responsibility of Subcommittee D18.16 on Grouting.

Current edition approved April 15, 1993. Published August 1993. Originally published as D 4320 – 84. Last previous edition D 4320 – 84.

² *Annual Book of ASTM Standards*, Vol. 04.08.

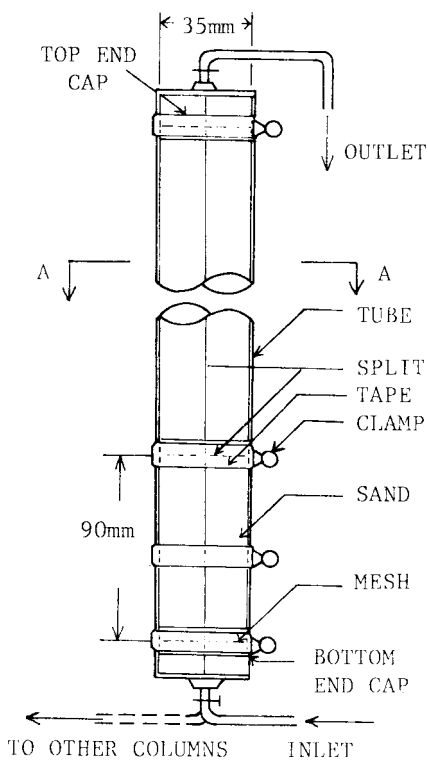

FIG. 1 Specimen Mold

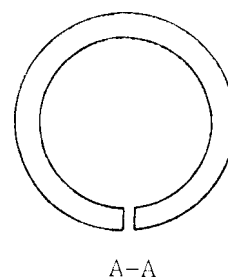

FIG. 3 Split tube multiple specimen mold

6.2 *Formation of Soil Specimen*—The mold to be used is assembled (with the top cap removed) and held vertically in a stable fashion while the soil sample is prepared using the following procedure:

6.2.1 A small piece of screen made of inert material is placed over the grout inlet at the bottom of the mold to retain filter material.

NOTE 6—The term “inert” refers to a material which does not interact in any way with the components of the specific grout being used.

6.2.2 The lower portion of the mold is filled with a layer (approximately 0.5 to 1 in. (12.5 to 25.4 mm)) of coarse sand or pea gravel to serve as a filter to disperse grout over the entire area of the specimen.

6.2.3 Insert the leveling device and smooth the surface of the filter material perpendicular to the long axis of the mold. Remove the leveling device and insert a piece of inert screen, having a diameter no more than 0.1 in. (2.5 mm) smaller than the inside of the mold. Position the screen flat on the filter surface.

6.2.4 The soil to be grouted is placed in layers and compacted to the desired density.

NOTE 7—Compaction may be done by tamping, tapping, or vibration. The method used shall be noted in the report. Satisfactory density control can be obtained by weighing sufficient soil to produce a 1-in. (25-mm) layer at the desired density and compacting this soil until a 1-in. layer thickness is obtained. If a multiple specimen mold is used, an inert screen shall be inserted at the interface between the specimens, as noted on the outside of the mold. When the top specimen is compacted and the inert screen is in place, construct the top filter as in 6.2.2 and assemble the top cap.

6.2.5 Alternatively, inert porous discs may be placed on top and at the bottom of specimens prior to grouting, so that the samples will not require future capping. Discs shall have porosities equal to or greater than that of the ungrouted specimen and shall fit the specimen molds with a clearance of between 0.01 to 0.02 in. (0.25 to 0.5 mm). When molds for multiple specimens are used, inert screens shall be used between adjacent top and bottom discs.

7. Grout Injection

7.1 Fill the grout injection tank with enough water to represent three times the volume of voids in the soil specimens, and pump this water through the specimens from the bottom to the top under a pressure of 5 psi (34.5 kpa) or less to enhance saturation. If this process takes less than 30 min, let the sample remain filled with water until 30 min has elapsed.

7.1.1 Tap water may be used whenever its composition is similar to site ground water, or whenever it does not change

but otherwise as large as possible, and scissors for cutting.

4.5 *Leveling Device*—A leveling plate attached to a rod of sufficient length such that the plate can be oriented perpendicular to the long axis of the mold at any height within the mold, capable of fitting inside the mold with approximately 0.25-in. (6-mm) clearance.

4.6 *Moist Room or Cabinet*—A moist room or cabinet capable of maintaining a temperature of 73.4 ± 2.0°F (23.0 ± 1.1°C) and a relative humidity of not less than 96 % for moist curing specimens.

NOTE 5—Deviations from standard curing conditions are to be noted in the report.

5. Size of Specimens

5.1 Compression test specimens shall be right circular cylinders having a minimum diameter of 1.4 in. (36 mm). The height shall be between two and three times the diameter (2.3 is recommended).

6. Molding Specimens

6.1 Either single or multiple specimen molds may be used.

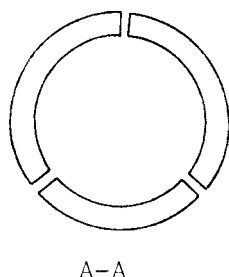

FIG. 2 Three piece multiple specimen mold

ASTM D 4320

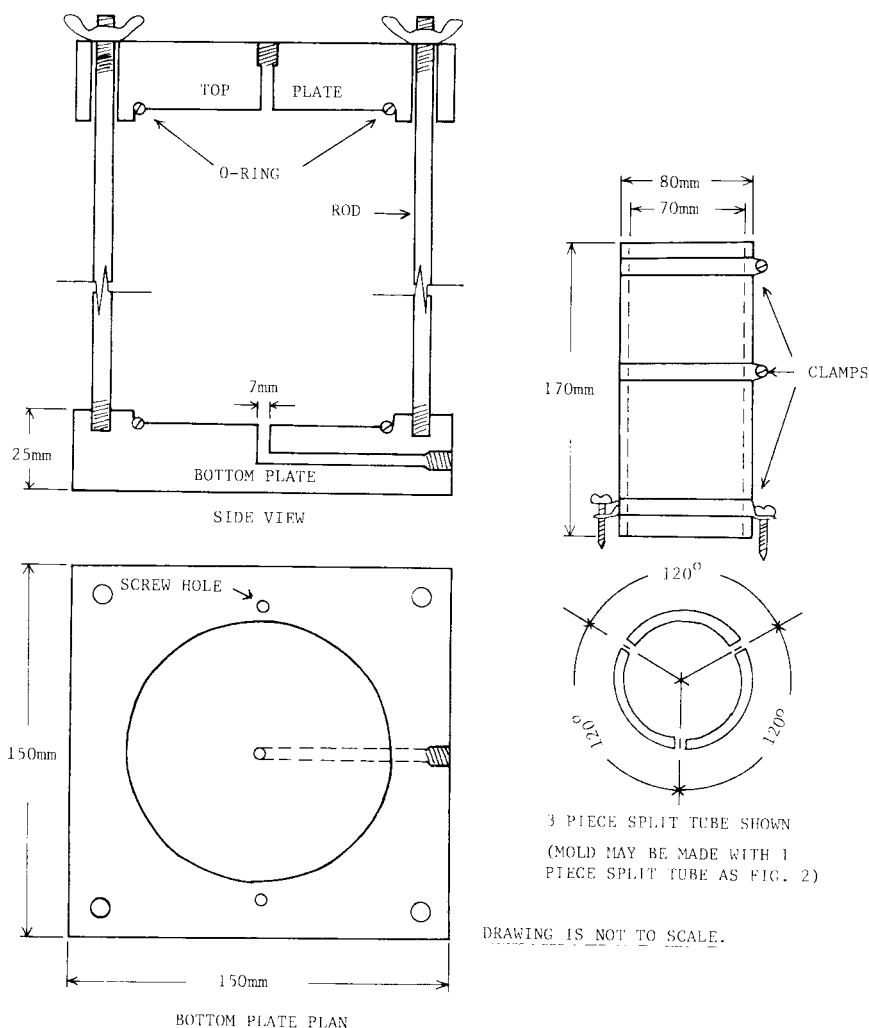

FIG. 4 Schematic Diagram of Specimen Preparation Mold

grout characteristics from those obtained with deionized water. Deionized water may be used, when the use of tap water is questionable. Site ground water or site supply water may also be used.

NOTE 8—Presaturation is not required for soils expected to be grouted above the ground water table.

7.2 Pour the predetermined quantities of the grout constituents into the empty injection tank and mix as required, but for less than 20 % of the gel time. Using a mixing propeller or a magnetic stirrer is permissible during the injection period for those grouts which would be similarly handled in the field.

7.3 Apply the design injection air pressure to the injection tank (10 to 20 psi (69 to 138 kPa) depending on grout viscosity and gelling time) and maintain constant during the pumping process. Injection should continue until the effluent shows that the water in the specimens has been replaced with grout. A specimen of this material shall be taken for a gel time check.

7.4 Leave specimens within the molds for at least long enough so that they can be removed without physical damage. For low concentration silicate-based grouts, this period may be as long as 48 h. For acrylamide and acrylate grouts, this period may be only a few minutes longer than the gel time.

8. Curing Specimens

8.1 Leave the specimens in the molds when they are to be tested within 16 h. After 16 h, the specimens may be removed from the mold provided that they have cured sufficiently to be undamaged by handling. Specimens removed from molds shall be sealed in plastic or cured in a moist room, as specified in 4.6 from the time of gelation until tested.

NOTE 9—Other curing environments, such as soaking in water, air drying, alternate wetting and drying, may be specified depending upon the intended end use of the data. These procedures shall be given in detail in the report.

9. Report

9.1 The report shall include the following:

9.1.1 Specimen identification number, classification, moisture content and other physical data which may be pertinent,

9.1.2 Grout components and proportions, temperature, viscosity, gel time, and water source,

9.1.3 Gradation of soil and dry and mass density of specimens as formed, dimensions and method of compaction, and temperature,

9.1.4 Details of curing environment and duration,

ASTM D 4320

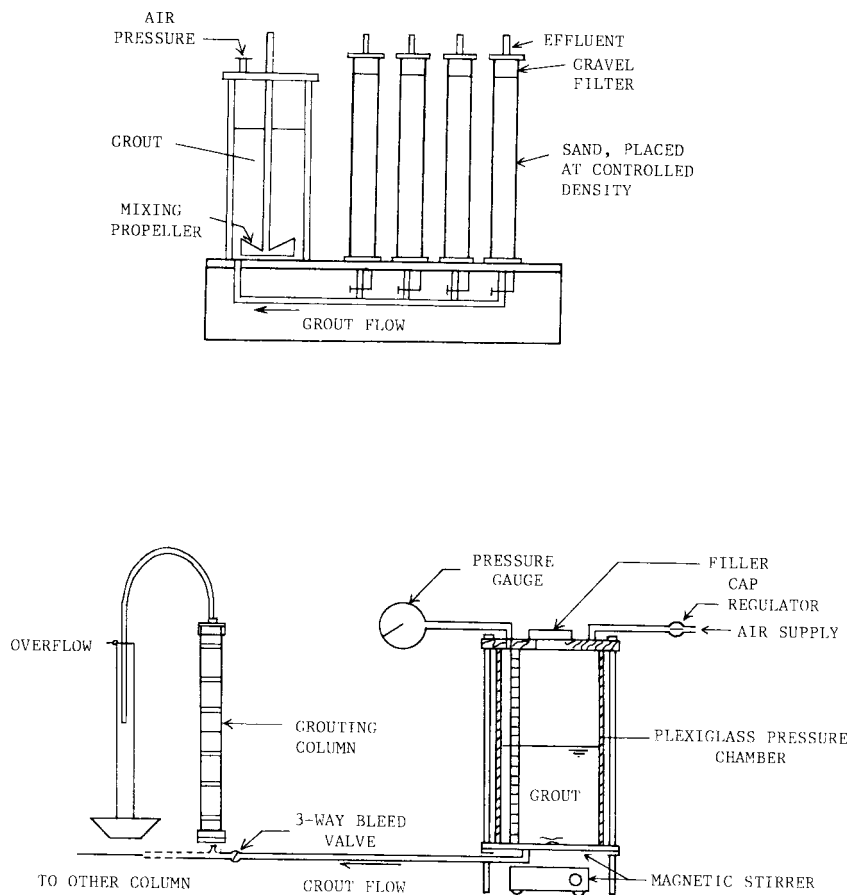

FIG. 5 Schematic Representation of Injection Systems

- 9.1.5 Deviations from standards, and
- 9.1.6 Dimensions of sample and mass density at time of test.

method, therefore, bias cannot be determined.

10. Precision and Bias

10.1 *Precision*—Data are being evaluated to determine the precision of this test method. In addition, Subcommittee D18.16 is seeking pertinent data from users of the test method.

11. Keywords

11.1 chemical grout; chemical grouted soils; curing conditions; grouting; grout injection; strength; unconfined compressive

10.2 *Bias*—There is no accepted reference value for this test

The American Society for Testing and Materials takes no position respecting the validity of any patent rights asserted in connection with any item mentioned in this standard. Users of this standard are expressly advised that determination of the validity of any such patent rights, and the risk of infringement of such rights, are entirely their own responsibility.

This standard is subject to revision at any time by the responsible technical committee and must be reviewed every five years and if not revised, either reapproved or withdrawn. Your comments are invited either for revision of this standard or for additional standards and should be addressed to ASTM Headquarters. Your comments will receive careful consideration at a meeting of the responsible technical committee, which you may attend. If you feel that your comments have not received a fair hearing you should make your views known to the ASTM Committee on Standards, 100 Barr Harbor Drive, West Conshohocken, PA 19428.