

This document is not an ASTM standard and is intended only to provide the user of an ASTM standard an indication of what changes have been made to the previous version. Because it may not be technically possible to adequately depict all changes accurately, ASTM recommends that users consult prior editions as appropriate. In all cases only the current version of the standard as published by ASTM is to be considered the official document.



Designation: D 4644 – 87 (Reapproved 1998)



Designation: D 4644 – 04

Standard Test Method for Slake Durability of Shales and Similar Weak Rocks¹

This standard is issued under the fixed designation D 4644; the number immediately following the designation indicates the year of original adoption or, in the case of revision, the year of last revision. A number in parentheses indicates the year of last reappraisal. A superscript epsilon (ε) indicates an editorial change since the last revision or reappraisal.

¹ This test method is under the jurisdiction of ASTM Committee D-18 on Soil and Rock and is the direct responsibility of Subcommittee D18.12 on Rock Mechanics. Current edition approved Feb. 2, 1987; 1, 2004. Published April February 2004. Originally approved in 1987. Last previous edition approved in 1998 as D 4644 – 87 (1998).

1. Scope*

1.1 This test method covers the determination of the slake durability index of a shale or other similar rock after two drying and wetting cycles with abrasion.

1.2 All observed and calculated values shall conform to the guidelines for significant digits and rounding established in Practice D 6026.

1.2.1 The method used to specify how data are collected, calculated, or recorded in this standard is not directly related to the accuracy to which the data can be applied in design or other uses, or both. How one applies the results obtained using this standard is beyond its scope.

1.3 The values stated in SI units are to be regarded as the standard. The values given in parentheses are provided for information only.

1.3.4 *This standard does not purport to address all of the safety concerns, if any, associated with its use. It is the responsibility of the user of this standard to establish appropriate safety and health practices and determine the applicability of regulatory limitations prior to use.*

2. Referenced Documents

2.1 *ASTM Standards:*²

D 653 Terminology Relating to Soil, Rock, and Contained Fluids

D 2113 Practice for Diamond Core Drilling for Site Investigation

D 2216 Test Method for Laboratory Determination of Water (Moisture) Content of Rock and Soil

D 3740 Practice for Minimum Requirements for Agencies Engaged in Testing and/or Inspection of Soil and Rock as Used in Engineering Design and Construction

D 5079 Practices for Preserving and Transporting Rock Core Samples

D 6026 Practice for Using Significant Digits in Geotechnical Data

E 11 Specification for Wire-Cloth and Sieves for Testing Purposes

3. Terminology

3.1 For terminology used in this test method, refer to Terminology D 653

3.2 Definitions of Terms Specific to This Standard:

3.2.1 slake durability index—the percentage by dry mass retained of a collection of shale pieces on a 2.00 mm (No. 10) sieve after two cycles of oven drying and 10 min of soaking in water with a standard tumbling and abrasion action.

4. Significance and Use

4.1 The test method is used to estimate qualitatively the durability of weak rocks in the service environment. **(1-7)**³.

4.2 This test method is used to assign quantitative durability values to weak rocks. A primary example is the Franklin Rating System **(1)**.

NOTE 1—The quality of the result produced by this standard is dependent on the competence of the personnel performing it, and the suitability of the equipment and facilities used. Agencies that meet the criteria of Practice D 3740 are generally considered capable of competent and objective testing.

² For referenced ASTM standards, visit the ASTM website, www.astm.org, or contact ASTM Customer Service at service@astm.org. For Annual Book of ASTM Standards, Vol 14.02, Standards volume information, refer to the standard's Document Summary page on the ASTM website.

³ The boldface numbers in parentheses refer to the list of references at the end of this standard.

sampling, inspection, and so forth. Users of this standard are cautioned that compliance with Practice D 3740 does not in itself assure reliable results. Reliable results depend on many factors; Practice D 3740 provides a means of evaluating some of those factors.

5. Apparatus

5.1 *Slake Durability Device*—The drum (Fig. 1) shall be made of 2.00 mm (No. 10) square-mesh, woven-wire cloth, conforming to the requirements of Specification E 11. It shall be cylindrical in shape, with a diameter of 140 mm (5.5 in.) and a length of 100 mm (3.9 in.). The ends shall be rigid plates, with one removable end. It must be sufficiently strong to retain its shape during use, but neither the exterior of the mesh nor the interior of the drum shall be obstructed by a support. The drum shall be able to withstand a temperature of 110 ± 5°C (230 ± 9°F). A trough shall support the drum in a horizontal manner such that the drum is free to rotate about its axis. The trough shall be capable of being filled with slaking fluid to 20 mm (0.8 in.) below the drum axis, and shall allow at least 40 mm (1.6 in.) unobstructed clearance between the trough and the bottom of the mesh. The drum shall be rotated by a motor capable of maintaining a speed of 20 rpm, constant to within 5 %, for a period of 10 min. Devices conforming to these requirements are commercially available.

5.2 *Drying Oven*, thermostatically controlled, capable of maintaining a temperature of 110 ± 5°C (230 ± 9°F).

5.3 *Balance*, sensitive to 1 g and having a 2000-g capacity.

5.4 *Miscellaneous Apparatus*, including a brush and hammer.

5.5 *Distilled Water*.

6. Test Sample and Specimen

6.1 Collect, transport, and store test samples and test specimens in such a manner as to retain the natural water content using the guidelines in Practices D 2113 and D 5079 and Test Method D 2216.

6.2 The test specimen shall consist of ten representative, intact, roughly equidimensional shale fragments weighing 40 g to 60 g each. These fragments may be naturally occurring or may be produced by breaking with a hammer. Such fragments may be obtained from rock cores or from test pits, and their sizes will vary with the method of sampling. Break off any sharp corners, if possible, and remove any dust by brushing the sample fragment just prior to weighing. The total sample test specimen shall weigh 450 to 550 g.

6.2 Transport and store the sample in such a manner as to retain the natural water content.

7. Procedure

7.1 Place the shale fragments

7.1 Photograph specimen prior to placement in the drum. Weigh, and dry in drum.

7.2 *Water Content*—Using Test Method D 2216, determine the oven for 16 h or to constant mass. Allow water content of each test specimen before testing. This shall be done with the shale and fragments in the drum to cool at room temperature be used for 20 min and weigh again. Calculate the natural water content as follows:

$$w = [(A - B)/(B - C)] \times 100 \tag{1}$$

where:

w = percentage water content,

A = mass of drum plus sample at natural moisture content, g,

B = mass of drum plus oven-dried sample before actual testing.

7.3 Mount the first cycle, g, and

C = mass of drum, g.

7.2 Mount the drum in the trough and couple to the motor. Fill the trough with distilled water at room temperature to 20 mm (0.8 in.) below the drum axis. Rotate the drum at 20 rpm for a period of 10 min. Record the water temperature at the beginning and end of the run.

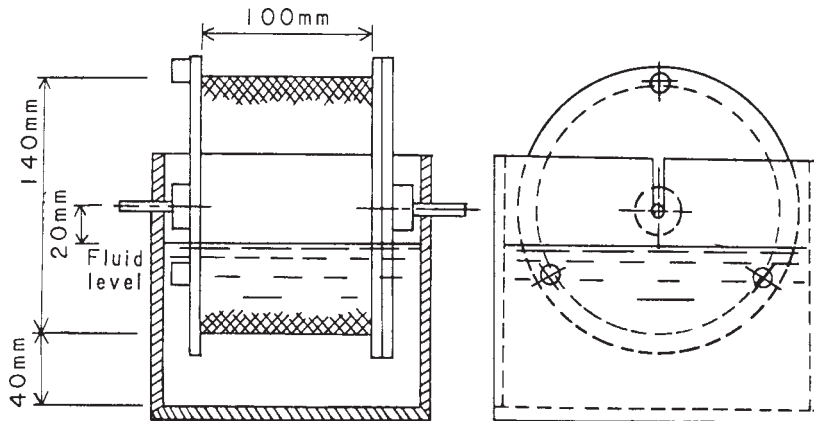

FIG. 1 Critical Dimensions of Slake Durability Equ Devipmce Showing Critical Dimensions

7.34 Remove the drum from the trough immediately after the rotation period is complete and dry the drum and the sample specimen retained in the oven for 16 h, or to constant mass:

7.4 Weigh the drum same as in 7.2 and sample to obtain the oven-dried mass for the second cycle. Repeat 7.2 mass.

7.5 Repeat 7.3 and 7.3. Again weigh the drum and sample 7.4 to obtain a final mass.

7.5 Photograph materials oven-dried mass for the second cycle.

7.6 Photograph specimen retained and file a copy of the photo with the laboratory report, or record standard verbal descriptions, as follows:

7.56.1 Type I—Retained pieces specimen remain virtually unchanged.

7.56.2 Type II—Retained materials specimen consist of large and small pieces:

7.5.3 fragments.

7.6.3 Type III—Retained material specimen is exclusively small fragments.

7.67 See Fig. 2 for representative photographs of the three types.

8. Calculations

8.1 Calculate the slake durability index (second cycle), as follows:

$$I_d(2) = [(W_F - C)/(B - C)] \times 100 \tag{1}$$

where:

$I_d(2)$ = slake durability index (second cycle),

B = mass of drum plus oven-dried sample specimen before the first cycle, g,

W_F = mass of drum plus oven-dried sample specimen retained after the second cycle, g, and

C = mass of drum, g.



FIG. 2 Illustration of Fragment Types Retained

9. Report

9.1 The report shall include the following:

9.1.1 Description of the ~~material~~ specimen and where it was obtained.

9.1.2 Slake durability index (second cycle) to the nearest 0.1 %.

9.1.3 Range and average value of the water temperature.

9.1.4 Natural water content.

9.1.5 Description of the appearance of the fragments retained in the drum (see 7.56).

10. Precision and Bias

10.1 ~~Test data on precision is not presented due to the nature of shale and other similar rock tested by this test method-i. It is either not feasible or too costly at this time to produce multiple specimens which have uniform physical properties. Any variation observed on the data is just as likely to be due to specimen variation as to operator or laboratory testing variation: Subcommittee D18.12 welcomes proposals that would allow for development of a valid precision statement. There is no accepted reference value of shale or weak rock for this test method; therefore, bias cannot be determined.~~

11. Keywords

11.1 abrasion resistance; shale; slake durability; weak rocks

REFERENCES

- (1) Franklin Trow Associates, "Field Evaluation of Shales for Construction Projects," Research and Development Project No. 1404, Ministry of Transportation and Communications, Research and Development Branch, Downsview, Ontario, March 1979.
- (2) Chapman, D. R., "Shale Classification Tests and Systems: A Comparative Study," MSCE Thesis and Joint Highway Research Project No. 75-11, Purdue University, West Lafayette, IN, June 1975, 90 pp.
- (3) Deo, P., "Shales as Embankment Materials," Ph.D. Thesis and Joint Highway Research Project No. 45, Purdue University, West Lafayette, IN, December 1972, 202 pp.
- (4) International Society for Rock Mechanics, "Suggested Methods for Determining Slake-Durability Index Properties," Commission on Standardization of Laboratory and Field Tests, November 1972.
- (5) Lutton, R. J., "Design and Construction of Compacted Shale Embankments, Volume 3, Slaking Indexes for Design," Report No. FHWA-RD-77-1, Federal Highway Administration, Washington, DC, February 1977.
- (6) Surendra, M., "Additives to Control Slaking in Compacted Shales," Ph.D. Thesis and Joint Highway Research Project No. 80-6, Purdue University, West Lafayette, IN, May 1980, 277 pp.
- (7) Oakland, M. W., and Lovell, C. W., "Classification and Other Standard Tests for Shale Embankment," Joint Highway Research Project No. 82-4, Purdue University, West Lafayette, IN, February 1982, 171 pp.

SUMMARY OF CHANGES

In accordance with Committee D18 policy, this section identifies the location of changes to this standard since the last edition (D 4644 – 87 (1998)) that may impact the use of this standard.

- (1) As required, a footnote about Summary of Changes was added to the title of Section 1.
- (2) Added standard paragraphs for significant digits and rounding established by Practice D 6026
- (3) Added Terminology D 653 , Practice D 2113, Test Method D 2216, Practice D 3740, Practice D 5079, Practice D 6026.
- (4) Added 3.1 referencing Terminology D 653, and renumbered section accordingly.
- (5) Added Note 1 referencing Practice D 3740.
- (6) Moved 6.2 up to 6.1 and added reference to Practice D 2113, Test Method D 2216, and Practice D 5079.
- (7) Section 7. Changed all reference to material to specimen and changed pieces to fragments.
- (8) Added 7.1 about photographing test specimen before testing and renumbered accordingly.
- (9) Took out section in 7.1 on calculating initial water content and referred user to Test Method D 2216 for determining water content.
- (10) Reworded 7.3 and 7.4 to remove instructions contained in Test Method D 2216.
- (11) Changed sample to specimen in 8.1.
- (12) The word "material" was changed to "specimen" in 9.1.1.
- (13) Section 10 was re-worded to conform with the D18 standards preparations manual.
- (14) Added Summary of Changes section.

ASTM International takes no position respecting the validity of any patent rights asserted in connection with any item mentioned in this standard. Users of this standard are expressly advised that determination of the validity of any such patent rights, and the risk of infringement of such rights, are entirely their own responsibility.

This standard is subject to revision at any time by the responsible technical committee and must be reviewed every five years and if not revised, either reapproved or withdrawn. Your comments are invited either for revision of this standard or for additional standards and should be addressed to ASTM International Headquarters. Your comments will receive careful consideration at a meeting of the responsible technical committee, which you may attend. If you feel that your comments have not received a fair hearing you should make your views known to the ASTM Committee on Standards, at the address shown below.

This standard is copyrighted by ASTM International, 100 Barr Harbor Drive, PO Box C700, West Conshohocken, PA 19428-2959, United States. Individual reprints (single or multiple copies) of this standard may be obtained by contacting ASTM at the above address or at 610-832-9585 (phone), 610-832-9555 (fax), or service@astm.org (e-mail); or through the ASTM website (www.astm.org).