



Standard Test Method for Laboratory Miniature Vane Shear Test for Saturated Fine-Grained Clayey Soil¹

This standard is issued under the fixed designation D 4648; the number immediately following the designation indicates the year of original adoption or, in the case of revision, the year of last revision. A number in parentheses indicates the year of last reapproval. A superscript epsilon (ϵ) indicates an editorial change since the last revision or reapproval.

1. Scope *

1.1 This test method covers the miniature vane test in very soft to stiff saturated fine-grained clayey soils ($\phi = 0$). Knowledge of the nature of the soil in which each vane test is to be made is necessary for assessment of the applicability and interpretation of the test results.

NOTE 1—It is recommended that the miniature vane test be conducted in fine-grained, predominately clay soils with an undrained shear strength less than 1.0 tsf (100 kPa) which are defined as stiff according to Practice D 2488. Vane failure conditions in higher strength clay and predominantly silty soils may deviate from the assumed cylindrical failure surface, thereby causing error in the measured strength.

1.2 This test method includes the use of both conventional calibrated torque spring units (Method A) and electrical torque transducer units (Method B) with a motorized miniature vane shear device.

1.3 Laboratory vane is an ideal tool to investigate strength anisotropy in the vertical and horizontal directions, if suitable samples (specimens) are available.

1.4 The values stated in inch-pound units are to be regarded as the standard. The values given in parentheses are for information only.

1.5 *This standard does not purport to address all of the safety concerns, if any, associated with its use. It is the responsibility of the user of this standard to establish appropriate safety and health practices and determine the applicability of regulatory limitations prior to use.*

2. Referenced Documents

2.1 ASTM Standards:

- D 1587 Practice for Thin-Walled Tube Sampling of Soils²
- D 2488 Practice for Description and Identification of Soils (Visual-Manual Procedure)²
- D 2573 Method for Field Vane Shear Test In Cohesive Soil²
- D 3740 Practice for Minimum Requirements for Agencies Engaged in the Testing and/or Inspection of Soil and Rock as used in Engineering Design and Construction³

¹ This test method is under the jurisdiction of ASTM Committee D18 on Soil and Rock and is the direct responsibility of Subcommittee D18.13 on Marine Geotechnics.

Current edition approved Feb. 10, 2000. Published April 2000. Originally published as D 4648 – 87. Last previous edition D 4648 – 94.

² *Annual Book of ASTM Standards*, Vol 04.08.

³ *Annual Book of ASTM Standards*, Vol 04.09.

D 4220 Practices for Preserving and Transporting Soil Samples²

3. Terminology

3.1 Definitions of Terms Specific to This Standard:

3.1.1 *torque*—the product of the magnitude of a force and the perpendicular distance of the line of action of the force from a specified axis of rotation.

3.1.2 *torque spring*—an elastic spring that can be calibrated to provide a measure of torque that is proportional to the rotation (about a central longitudinal axis) of one end of the spring relative to a fixed condition at the opposite end of the spring.

3.1.3 *torque transducer*—an electronic measuring device that can be calibrated to provide a measure of torque.

4. Summary of Test Method

4.1 The miniature vane shear test consists of inserting a four-bladed vane in the end of an undisturbed tube sample or remolded sample and rotating it at a constant rate to determine the torque required to cause a cylindrical surface to be sheared by the vane. This torque is then converted to a unit shearing resistance of the cylindrical surface area. The torque is measured by a calibrated torque spring or torque transducer that is attached directly to the vane.

5. Significance and Use

5.1 The miniature vane shear test may be used to obtain estimates of the undrained shear strength of fine-grained soils. The test provides a rapid determination of the shear strength on undisturbed, or remolded or reconstituted soils.

NOTE 2—Notwithstanding the statements on precision and bias contained in this test method: The precision of this test method is dependent on the competence of the personnel performing it and the suitability of the equipment and facilities used. Agencies that meet the criteria of Practice D 3740 are generally considered capable of competent and objective testing. Users of this test method are cautioned that compliance with Practice D 3740 does not in itself ensure reliable testing. Reliable testing depends on several factors; Practice D 3740 provides a means for evaluating some of those factors.

6. Interferences

6.1 *Vane Disturbance*—The remolded zone around a vane blade resulting from insertion is generally assumed to be small and have little or no effect on the stress-strain properties of the

*A Summary of Changes section appears at the end of this standard.

sediment being tested. In reality, the volume of soil disturbed by the insertion of the vane blade into the assumed cylindrical volume of soil being tested may be significant. It is recommended that the vane displace no more than 15% of the soil being tested as defined by the vane area ratio presented in Fig. 1.

7. Apparatus

7.1 *Vane Blade*—The vane assembly shall consist of four rectangular bladed vanes, as illustrated in Fig. 2. It is recommended that the height of the vane be twice the diameter (2:1), although vanes with a height equal to the diameter (1:1) also may be used (see Note 3). Vane blade diameter (*D*) may vary from 0.5 to 1.0 in. (12.7 to 25.4 mm).

7.2 *Vane Device*—The vane device should be motorized and shall rotate the torque spring at a constant rate of 60 to 90°/min (17 to 26 m rd/s). The vane/spring rotation device shall have an indicator or recording system that displays/records deflection (torque) of the calibrated spring or electrical transducer and, where possible, vane blade rotation.

7.3 *Torque Measuring Device*—The torque measuring device shall be a conventional torque spring, electrical torque transducer, or any other measuring device capable of the accuracy prescribed herein and may be part of the vane device. The torque measuring device shall be capable of measuring the torque to at least 2 significant digits.

NOTE 3—Since many clays are anisotropic with respect to strength, the relative importance of horizontal, as distinct from vertical, shearing surfaces can influence the test results. For this reason it is important that the recommended ratio of height to diameter be respected unless the intent is to vary the ratio in order to determine the horizontal and vertical strengths separately. For more detailed discussion on effects of height to

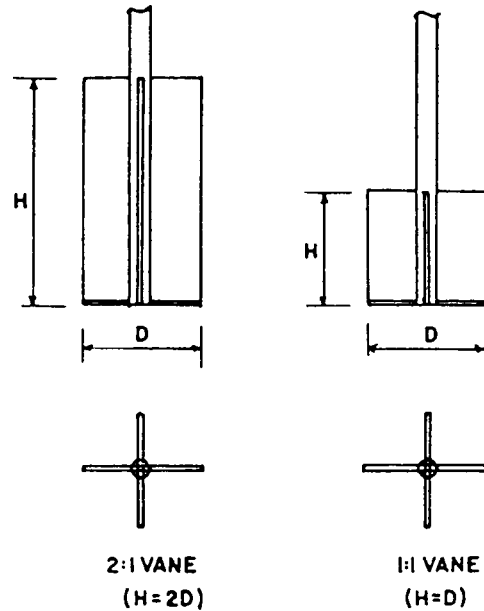

FIG. 2 Miniature Vane Blade Geometry

diameter ratio as well as vane shape, refer to Refs. (1) and (2).⁴

8. Preparation and Testing of Samples

8.1 *Specimen Size*—Specimens should have a diameter sufficient to allow clearance of at least two blade diameters between all points on the circumference of the shearing surface and the outer edge of the sample.

⁴ The boldface numbers in parentheses refer to the list of references at the end of this standard.

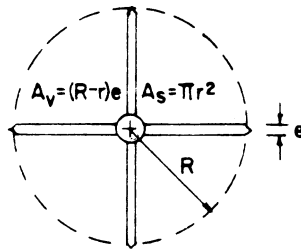

$$V_A = \frac{4(R-r)e + \pi r^2}{\pi R^2}$$

Where: V_A = Vane Area Ratio
 R = Radius of Failure Cylinder (in or mm)
 r = Radius of Vane Shaft (in or mm)
 e = Vane Blade Thickness (in or mm)

VANE TYPE	BLADE DIA. in (mm)	SHAFT DIA. in (mm)	BLADE THICKNESS in (mm)	AREA RATIO (%)
Miniature	0.50 (12.7)	0.1275 (3.5)	0.019 (0.05)	13.7

FIG. 1 Vane Area Ratio for ASTM Vanes

8.2 *Undisturbed Vane Strength*—Prepare undisturbed specimens from large undisturbed samples secured in accordance with Practice D 1587, and handle and transport in accordance with the practices for Group C and D Samples in Practices D 4220. Tests may be run in the sampling tube, eliminating the need for extrusion. Handle specimens carefully to prevent disturbance or loss of moisture content. Trim flat the end of the sample where the vane will be inserted. The sample shall be perpendicular to the wall of the tube.

8.3 *Remolded Vane Strength*—Conduct remolded miniature vane strength tests on failed specimens similar to remolded field vane tests (Method D 2573) by rotating the vane rapidly through a minimum of five to ten revolutions.

NOTE 4—Remolded shear strength measurements are conventionally obtained by conducting strength tests on specimens encased in a thin rubber membrane, to prevent change in water content, and remolded by hand (hand remolding). Field vane remolded strength has however been obtained by rotating the vane rapidly through a minimum of five to ten complete revolutions and conducting a vane test within 1 min of the remolding process (machine remolding). A machine remolded test yields a vane strength value that is considered more a residual strength. The machine remolded strength is typically higher than the hand remolded strength and, as a consequence, produces lower sensitivities. In many sensitive clayey soils, residual strengths may be obtained within one to two revolutions or less. If such soils are being tested, it is recommended that several remolded strengths be obtained using the standard five to ten revolutions for verification. If no major remolded strength differences are noted, remolded strengths may be obtained at less than the recommended five to ten revolutions.

NOTE 5—In cases where electrical torque transducers with wires for signal transmission are utilized, the remolded miniature vane strength may be obtained by rotating the vane one complete revolution in one direction and then again in the opposite direction a number of times to produce the desired five to ten complete revolutions.

9. Preparation of Apparatus

9.1 *Vane Blade Damage*—Carefully check each vane prior to each use for bent shifts and blades and imperfections that could alter the vane failure surface from the assumed cylindrical surface.

10. Calibration

10.1 Conduct periodically calibration of the spring units (or torque transducers) to ensure proper operation of the miniature vane device and repeatability of the torque spring or transducers. Calibration is accomplished by the application of calibrated weights onto a calibrated wheel to produce a known torque (lever arm X weight). Secure the vane shear unit in such a way that the vane spring (torque unit) is in a horizontal position. Then insert the calibration wheel in place of the vane blade. The calibration wheel, calibration string, and calibration weights all shall hang free of any obstructions. Dimensions of the calibration wheel shall be noted; specifically the lever arm.

10.2 For each vane torque spring to be used, apply a series of calibration weights to the calibration wheel to develop a plot of spring deflection (in degrees) versus torque (in lbf-in. or N·m). Carefully fasten each calibration weight to the calibration string and allow to deflect the spring. Record the deflection of the spring (in degrees) and applied torque for each weight applied. The calibration wheel configuration, lever arm, weights, and resulting torque shown in Fig. 3 is recommended

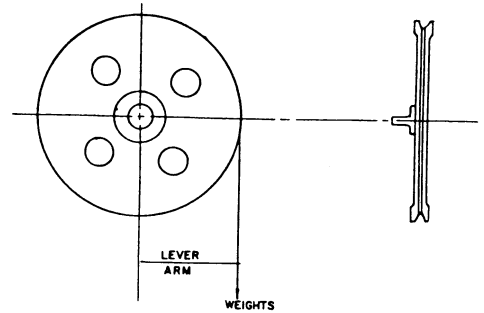

WEIGHT GRAMS	SUGGESTED LEVER ARM - 2.265 INCHES (57.53 mm)	
	TORQUE	
	(IN-LBS)	(mm-gm)
1	0.005	57.53
10	0.05	573.31
50	0.25	2876.55
100	0.50	5753.10
500	2.50	28765.50
1000	5.00	57531.00

FIG. 3 Typical Calibration Wheel Configuration and Weight Selections

for consideration in the calibration procedure.

11. Application and Measurement of Vane Blade Torque

11.1 Apply the torque to the vane by a conventional torque spring (Fig. 4a) or an electrical torque transducer (Fig. 4b) that is rotated with the vane/spring rotation device. The torque spring or transducer shall produce a repeatable linear relationship between spring deflection (degrees) or transducer output (mV) and torque applied.

NOTE 6—Since vane strength may be greatly influenced by the rate at which shear occurs, it is recommended that torque be applied using a motorized vane device. A hand crank manual device may be utilized, but is not recommended due to the potential variation in rate of shear.

NOTE 7—When the miniature vane test is conducted using a calibrated torque spring, the top of the spring unit is rotated at a constant rotation rate while the bottom of the spring most often remains stationary or nearly stationary until enough energy (torque) is built up in the spring. Just prior to or at failure, the bottom of the spring and vane begin to rotate (generally slowly) as failure begins. The torque applied by the spring soon overcomes the shearing resistance of the soil and the vane blade rotates rapidly to bring the soil to total failure. Thus, depending upon the stiffness of the calibrated torque spring, soil strength, and consistency, the rate of shear and possibly the shear strength may vary.

NOTE 8—It should be recognized that there is a fundamental difference in the failure modes between miniature vane tests made using a calibrated torque spring and an electrical transducer. An electrical torque transducer will produce a strain-controlled failure of the soil, whereas a calibrated torque spring will produce failure that varies somewhere between purely stress-controlled and strain-controlled conditions. Using an electrical torque transducer, the constant rate of rotation applied to the top of the torque transducer is transmitted directly to the vane blade. The resulting strain-controlled failure could result in a higher rate of shear than that produced using a calibrated torque spring.

12. Vane Rotation and Shearing Rate

12.1 Apply torque to the vane/spring at a rotation rate of 60 to 90°/min (see Note 9).

NOTE 9—The rate of vane rotation has two major effects on the resulting measured vane shearing strength. The first is preventing drainage

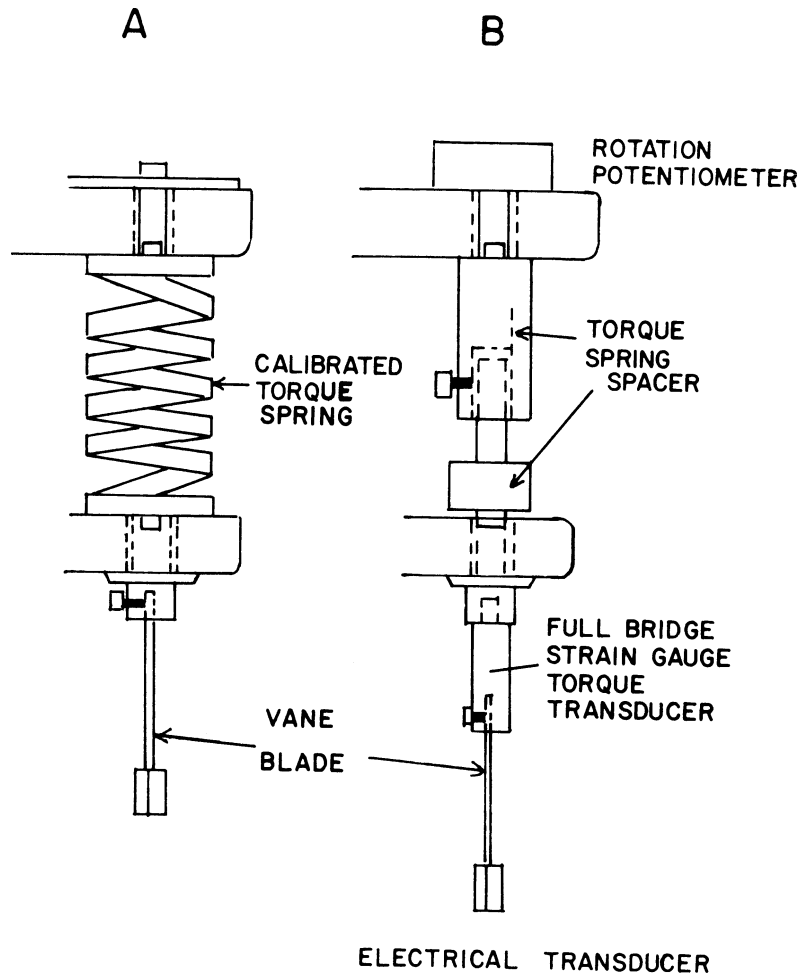

FIG. 4 Vane Torque Spring and Electrical Transducer Details Geometry

so that a truly undrained shear strength is measured. The second resembles a viscous effect: the faster a soil is sheared the higher is its measured strength. There are currently two approaches for determining the vane rotation and shearing rate. These approaches are (1) angular shear velocity approach, and (2) Blight's drainage approach. A more detailed discussion of these two approaches can be found in Refs. (3) and (4), respectively.

13. Miniature Vane Test Procedures

13.1 Fasten the vane shear unit, as well as the specimen container, securely to a table or frame to prevent movement during a test. Insert the vane in the sample to a minimum depth equal to twice the height of the vane blade to ensure that the top of the vane blade is embedded at least one vane blade height below the sample surface (see Note 10).

NOTE 10—If a very long shaped vane (12 in. (305 mm)) is employed to test within a sample, then the adhesion between the shaft and the soil must be evaluated. The adhesion is evaluated by inserting a shaft, without the vane, having the same dimensions as the actual vane shaft, into the soil to the level to be tested and noting the resulting torque versus rotation. The torque is subtracted from actual test results. To eliminate this correction, the actual torque shaft can be encased in a frictionless sleeve to prevent adhesion from occurring.

13.2 Take an initial reading. Hold the sample firmly to prevent rotation. Initiate mechanically rotation of the vane so as to rotate the top of the spring or transducer at a constant rate

of 60 to 90°/min in accordance with 12.1. Record spring deflection or torque transducer readings at least every 5° of rotation until the spring deflection does not increase (which is considered failure) or until a maximum of 180° of rotation is obtained. During the rotation of the vane, hold the vane blade at a fixed elevation. Record the maximum torque and intermediate torque readings if required. Remove and clean the vane blade if necessary. Secure a representative sample of the specimen to determine the moisture content. Inspect the soil for inclusions such as sand and gravel and cracking of the failure surface, which may influence test results. Record the findings.

13.3 Following the determination of the maximum torque, determine the remolded vane strength by rotating the vane rapidly through a minimum of five to ten revolutions; the determination of the remolded strength should be started immediately after completion of rapid rotation and in all cases within 1 min after the remolding process. Repeat the procedure in 13.1 and 13.2.

14. Calculation

14.1 Calculate the undrained shear strength in the following manner (see Note 11). The turning moment required to shear the soil is given as follows:

$$T = \tau \times K \tag{1}$$

where:

- T = torque, lbf·ft (N·m),
- τ = undrained shear strength, lbf/ft² (Pa), and
- K = vane blade constant, ft³ (m³).

NOTE 11—The undrained shear strength (τ) determined in this laboratory procedure needs to be multiplied by a vane correction factor (μ) to give a field value of undrained shear strength, (τ)_{field} = $\mu(\tau)$ _{lab}. A more detailed discussion of the use of the vane correction factor is given in Refs. (5) and (6).

14.2 Assuming the distribution of the shear strength is uniform across the ends of the failure cylinder and around the perimeter, K is given as follows:

$$K = \frac{HD^2H}{3456} \left[1 + \frac{D}{3H} \right] \text{ (Inch-Pound Units)} \quad (2)$$

$$K = \frac{HD^2H}{2 \times 10^6} \left[1 + \frac{D}{3H} \right] \text{ (SI Units)} \quad (3)$$

where:

- D = measured diameter of the vane, in. (mm),
- H = measured height of the vane, in. (mm),

14.2.1 Thus, for a 0.5 by 0.5 in. (12.7 by 12.7 mm) vane:

$$K = 0.0001515 \text{ ft}^3 \text{ (reciprocal} = 6617 \text{ ft}^{-3}\text{)}$$

$$= 4.28 \times 10^{-6} \text{ m}^3,$$

and for a 0.5 by 1.0 in. (12.7 by 25.4 mm) vane,

$$K = 0.0002651 \text{ ft}^3 \text{ (reciprocal} = 3772 \text{ ft}^{-3}\text{)}$$

$$= 7.51 \times 10^{-6} \text{ m}^3.$$

14.3 Since the undrained shear strength, τ , is required, it is more useful to write the vane equation as follows:

$$\tau = T \times k \quad (4)$$

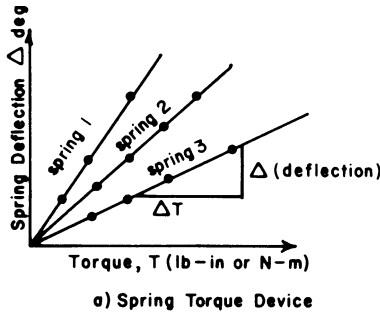

a) Spring Torque Device

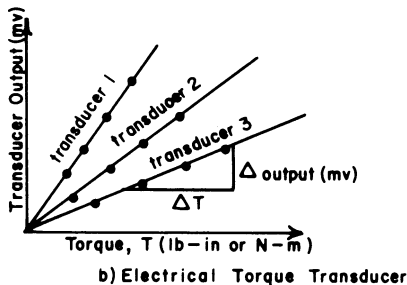

b) Electrical Torque Transducer

FIG. 5 Determination of Calibration Factors for Vane Torque Units

where:

$$k = \frac{1}{K} \text{ and}$$

T = measured torque, lbf·ft (N·m).

0.5 by 0.5 in. (12.7 by 12.7 mm) vane

$$k_1 = 6600 \text{ ft}^{-3} \text{ (} 2.34 \times 10^{+5} \text{m}^{-3}\text{)}$$

0.5 by 1.0 in. (12.7 by 25.4 mm) vane

$$k_2 = 3772 \text{ ft}^{-3} \text{ (} 1.33 \times 10^{+5} \text{m}^{-3}\text{)}$$

14.4 If the vane torque is to be measured utilizing a standard vane shear device by noting the deflection of springs with known constants, a relationship between vane torque and spring deflection may be established through the calibration procedure described in Section 10 as shown in Fig. 5a. Alternatively, a similar calibration curve for an electrical torque transducer may be developed as shown in Fig. 5b.

14.5 The torque, T , also may be expressed in terms of spring deflection in degrees, as follows:

$$T = \frac{(\Delta)}{(B)(12)} \text{ (Inch-Pound Units)} \quad (5)$$

$$T = \frac{\Delta}{B} \text{ (SI Units)} \quad (6)$$

where:

T = torque in lbf·ft (N·m),

B = slope of calibration curve in °/lbf·in. (see Fig. 5a) (°/N·m), and

Δ = deflection in degrees.

14.6 The shear strength (τ) may then be obtained from the following equation:

$$\tau = (\Delta)(b)k \quad (7)$$

where:

$$B = \text{slope} = \frac{\Delta \text{ deflection}}{\Delta \text{ torque}}$$

Example using a No. 2 Spring

$$B = \frac{151 \text{ deg}}{2.5 \text{ lb-in.}}$$

$$B = 60.4 \frac{\text{deg}}{\text{lb-in}}$$

$$B = \text{slope} = \frac{\Delta \text{ output}}{\Delta \text{ torque}}$$

Example Method (1)

$$B = \frac{2.0 \text{ mv}}{5.0 \text{ lb-in}} = 0.40 \frac{\text{mv}}{\text{lb-in}}$$

Method (2)

$$B = \frac{4 \text{ in (chart deflection)}}{5.0 \text{ lb-in}} = 0.8 \frac{\text{inch}}{\text{lb-in}}$$

- τ = undrained shear strength, lbf/ft² (N/m²),
 Δ = spring deflection, degrees (or transducer output in mV),
 b = (1/12B), lbf·ft/^o or $b = (1/B)$, N·m/^o, and
 k = 1/K, ft⁻³ (m⁻³).

14.7 Establish the spring deflection and torque relationship for each spring or transducer to be used in the vane shear tests as follows:

Springer/ Transducer No.	B	$b = (1/12B)$
<i>Weakest</i>	ex. $\frac{193}{1.0} = 193.0$	ex. $\frac{1}{193(12)} = 0.0004318$
etc.	etc.	etc.

14.8 Thus, for a 1:1 or 2:1 vane blade, shear strength may be computed by the following:

$$\tau = (\Delta)R \quad (8)$$

where:

- τ = shear strength in lbf/ft² (kPa),
 Δ = deflection in degrees or transducer output in mV, and
 R = (b) k constant.

Vane Size	1:1	2:1
Spring No.	$R = bk_1$	$R = bk_2$
<i>Weakest</i>	2.85 ^A	1.63
etc.	ex. (0.136) ^B	ex. (0.0780)
	etc.	etc.

^A In inch-pound units, yields τ in lbf/ft².

^B In SI units, yields τ in kPa.

15. Report

15.1 For each vane test report the following information:

- 15.1.1 Date of the test, personnel conducting test.
- 15.1.2 Boring number, sample or tube number, sample depth, vane test depth, soil type in accordance with Practice D 2488.
- 15.1.3 Size and shape of the vane, spring number or torque transducer number, include calibration curve or torque transducer constant, recorder settings.
- 15.1.4 Maximum torque reading, and intermediate readings if required for the undisturbed test, include torque transducer stress strain plots.
- 15.1.5 Maximum torque reading for the remolded test, and number of revolutions used to remold.
- 15.1.6 Rotation rate, rate of shear at vane blade edges, time to failure of the test (maximum rotation–rotation rate) where applicable.
- 15.1.7 Type vane apparatus used (manufacturer, model).
- 15.1.8 Notes on any deviations from standard procedure.

16. Precision and Bias

16.1 *Precision*—Due to the nature of soil tested by this method, it is too costly at this time to produce multiple specimens which have uniformed physical properties. Any variation observed in the data is just as likely to be due to specimen variation as to operator or laboratory testing variation. Subcommittee D18.13 welcomes proposals that would allow for development of a valid precision statement.

16.2 *Bias*—There is no accepted reference value for this test method; therefore bias cannot be determined.

17. Keywords

17.1 clays; laboratory; miniature; remolded; saturated; shear value; undisturbed; undrained strength

REFERENCES

- (1) Aas, G., "A Study of the Effect of Shape of Vane and Rates of Strain On In-Situ Shear Strength of Clays," *Proceedings 6th Intl. Conference on Soil Mechanics and Foundation Engineering*, Vol. 2, 1966, pp. 141–145.
- (2) Richardson, A., "In Situ Determination of Anisotropy," *Proceedings In Situ Measurements*, Vol. I, ASCE, 1974, pp. 336–349.
- (3) Perlow, M. and Richards, A. F., "Influence of Shear Velocity in Vane Shear Strength," *Journal of the Geotechnical Engineering Division, Proceedings of the American Society of Civil Engineers*, Vol. 103, No. GTI, 1977, pp. 19–32.
- (4) Lee, H. J., "State of the Art: Laboratory Determination of the Strength of Marine Soils," *Strength Testing of Marine Sediments: Laboratory and In Situ Measurements*, ASTM STP 883, ASTM 1985, pp. 181–250.
- (5) Ladd, C. C., Discussion: "Measurement of In Situ Shear Strength," *Proceedings In Situ Measurements*, Vol. II, ASCE, 1975, pp. 153–160.
- (6) Larsson, R., "Undrained Shear Strength," *Canadian Geotechnical Journal*, Vol. 17, No. 4, November 1980, pp. 591–602.

SUMMARY OF CHANGES

In accordance with Committee D18 policy, this section identifies the location of changes to this standard since the last edition (1994) that may impact the use of this standard.

- | | |
|--|--|
| (1) Added Section 3, Terminology, and included definitions of torque spring and torque transducer. | (4) Renumbered subsequent sections. |
| (2) Added Section 5, Significance and Use. | (5) Replaced existing 7.3 to allow alternative torque measuring devices and to set a measurement accuracy requirement. |
| (3) Added reference to Practice D 3740 in Section 5. | |

The American Society for Testing and Materials takes no position respecting the validity of any patent rights asserted in connection with any item mentioned in this standard. Users of this standard are expressly advised that determination of the validity of any such patent rights, and the risk of infringement of such rights, are entirely their own responsibility.

This standard is subject to revision at any time by the responsible technical committee and must be reviewed every five years and if not revised, either reapproved or withdrawn. Your comments are invited either for revision of this standard or for additional standards and should be addressed to ASTM Headquarters. Your comments will receive careful consideration at a meeting of the responsible technical committee, which you may attend. If you feel that your comments have not received a fair hearing you should make your views known to the ASTM Committee on Standards, at the address shown below.

This standard is copyrighted by ASTM, 100 Barr Harbor Drive, PO Box C700, West Conshohocken, PA 19428-2959, United States. Individual reprints (single or multiple copies) of this standard may be obtained by contacting ASTM at the above address or at 610-832-9585 (phone), 610-832-9555 (fax), or service@astm.org (e-mail); or through the ASTM website (www.astm.org).