



Standard Test Method for In Situ Stress and Modulus of Deformation Using the Flatjack Method¹

This standard is issued under the fixed designation D 4729; the number immediately following the designation indicates the year of original adoption or, in the case of revision, the year of last revision. A number in parentheses indicates the year of last reapproval. A superscript epsilon (ϵ) indicates an editorial change since the last revision or reapproval.

1. Scope

1.1 The flatjack test measures stress at a rock surface. The modulus of deformation and the long-term deformational properties (creep) may also be evaluated.

1.2 *Limitation*—The flatjack test measures stresses only at the surface of the test chamber. Undisturbed stress levels must be determined by theoretical interpretations of these data.

1.3 Assumptions and Factors Influencing the Data:

1.3.1 The stress relief is assumed to be an elastic, reversible process. In nonhomogeneous or highly fractured materials, this may not be completely true.

1.3.2 The equations assume that the rock mass is isotropic and homogeneous. Anisotropic effects may be estimated by testing in different orientations.

1.3.3 The flatjack is assumed to be 100 % efficient. The design and size requirements of 5.1 were determined to satisfy this requirement to within a few percent.

1.3.4 The jack is assumed to be aligned with the principal stresses on the surface of the opening. Shear stresses are not canceled by jack pressure. Orientating the tests in three directions in each plane tested prevents the misalignment from being excessive for at least one of the tests.

1.4 The values stated in inch-pound units are to be regarded as the standard.

1.5 *This standard does not purport to address all of the safety problems, if any, associated with its use. It is the responsibility of the user of this standard to establish appropriate safety and health practices and determine the applicability of regulatory limitations prior to use.*

2. Terminology

2.1 Definitions:

2.1.1 *cancellation pressure*—the pressure in the flatjack required to return the rock to its initial position.

2.1.2 *skin stress*—the tangential stress at the surface of an opening.

2.1.3 *undisturbed stress*—the stress field existing in a rock mass prior to excavation of an opening.

3. Summary of Test Method

3.1 The in situ stress in the rock mass is relieved by cutting a slot into the rock perpendicular to the surface of the test adit. The deformation caused by this stress relief is measured. A hydraulic flatjack is placed into the slot and is pressurized until the above-measured displacement is canceled. This reapplied stress is approximately equal to the stress in the rock mass at the test location in a direction perpendicular to the plane of the jack. The deformational characteristics of the rock mass are evaluated by incrementally loading the flatjack and measuring the deformation.

4. Significance and Use

4.1 *Tests in Orthogonal Directions*— The flatjack most accurately determines the stress parallel to the long axis of the adit, because this stress is the least affected by the presence of the opening. (The other tangential stress is highly concentrated.) In addition, if the adit is in a stress field where one of the stresses is significantly larger than the others (3 or 4 times), certain locations in the adit may be in very low compressive or even tensile stress. Flatjack tests in these locations can give anomalous and misleading results. Because of these factors, the test adit should have at least two, and preferably three, long (at least 4 to 5 times the diameter), straight sections at about 90° to each other. Testing should be distributed evenly in all three sections to provide redundant data and, if results in one section are anomalous, to allow the program to produce sufficient usable data.

5. Interferences

5.1 Personnel Prequalification:

5.1.1 *Test Personnel*—All personnel involved in performing the test, including the technicians and test supervisor, shall be formally prequalified.

5.1.2 *Drilling Personnel*—Quality drilling is important to achievement of successful flatjack tests. The drilling personnel should be capable of the precision drilling necessary to successfully produce the slot and instrument holes.

5.2 *Equipment Performance Verification*— The compliance of all equipment and apparatus with performance specifications apparatus shall be verified. If no requirements are stated, the manufacturer's specifications for the equipment shall be the required level of performance. Performance verification is

¹ This test method is under the jurisdiction of ASTM Committee D-18 on Soil and Rock and is the direct responsibility of Subcommittee D18.12 on Rock Mechanics.

Current edition approved Aug. 28, 1987. Published October 1987.

generally done by calibrating the equipment and measurement systems. Calibration and documentation shall be accomplished according to standard procedures.

5.3 *Local Geologic Features*—Local features, particularly faults, shear zones, etc., can influence the local stress field. Large inclusions in the rock can affect both the stress and deformational properties. Test locations should be carefully selected so that the effects of such features are minimized or, if they are the features of interest, accounted for fully.

5.4 *Influence of Excavations*—Other excavations intersecting the test adit will cause complex stress concentration effects by superposition. Flatjack tests should be located at least three diameters of the intersecting feature away from that feature. If the test adit is excavated by conventional methods, then the surfaces for testing should be further excavated by nonblasting techniques to remove loose material resulting from stress relief or blasting.

6. Apparatus

6.1 *Flatjacks*—Flatjacks shall be designed to operate at pressures of several thousand pounds per square inch when properly installed. The jacks shall be constructed so that the two main plates move apart in essentially a parallel manner over the range of the jack. The range shall be at least 0.25 in. (6 mm). The jacks should be square and no less than 2 ft (0.6 m) wide.

6.2 Transducers:

6.2.1 *Pressure*—Electronic transducers or hydraulic gages may be used to monitor flatjack pressure. The pressure transducer shall have an accuracy of at least ± 20 lb/in.² (± 0.14 MPa), including errors introduced by the readout system and a sensitivity of at least 10 lb/in.² (0.069 MPa).

6.2.2 *Deformation*—Deformation transducers include dial gages, Whittemore-type strain gages, and electronic transducers such as LVDT's or linear potentiometers. The transducer shall have an accuracy of at least ± 0.0001 in. (± 0.0025 mm) and a sensitivity of at least 0.00005 in. (0.0013 mm).

6.2.3 *Internal Gages*—Strain gages inside the flatjack shall be calibrated prior to installation in the jack. The effects of the hydraulic oil and ambient pressure increase on the gages shall be determined prior to testing.

6.3 *Mortar*—If mortar is used to cement the flatjack into the slot, a high-early strength, nonshrink material shall be used. The mortar may include up to 50 % clean sand by weight, with grain size between 20- and 60-mesh. Clean, potable water shall be used for the mortar. The cured mortar shall have a strength greater than the stress applied by the flatjack. The modulus of the mortar may be required to be removed from some of the determinations of rock modulus.

6.4 *Sawing Equipment*—Equipment used to saw a slot in the rock should be of a type where large center or end holes are not required. These large holes can cause serious changes in the stress field to be measured.

7. Procedure

7.1 *Groups at Each Test Station*—At least one group of jacks should be tested in each adit section. Each group should have three flatjacks installed horizontally inclined 45° and vertically. The jacks in each group should all be placed in one

part of the adit within 20 ft (6.1 m) of each other along the length of the adit.

7.2 Surface Preparation:

7.2.1 *Rock Quality*—The flatjack and deformation transducers should not be installed. Loose, broken, or drummy material may be detected by a dull, hollow sound when struck with a hammer; such material should be removed.

7.2.2 *Dimensions*—The prepared surface shall extend at least 1 ft (0.30 m) past either end of the flatjack slot and at least 1 ft (0.30 m) past the furthest measuring points. The transducers or flatjack shall be 1 ft (0.30 m) inside the prepared surface at any point (see Fig. 1).

7.2.3 *Method*—Drilling to a uniform depth may be required to prepare the rock face. Residual rock between the drill holes may be removed by moving the bit back and forth until a smooth surface is achieved. Alternatively, in hard, competent rock, controlled blasting with very small charges may be used to remove the residual rock. In softer material, coarse grinding, chipping, or cutting devices may be required.

7.2.4 *Smoothness*—Ideally, the prepared surface shall be a plane. The difference between the highest and lowest points on the prepared surface shall be not greater than 2 in. (50 mm).

7.3 *Transducer Installation*—Transducers shall be installed on the centerline normal to the flatjack, either at the surface or at depth. Transducers for stress determination shall be installed within $L/2$ of the flatjack slot, where L is the width of the flatjack.

7.4 *Slot Cutting*—The slot can be formed by sawing or by drilling overlapping holes in weak or highly fractured material. Vibration should be minimized. The slot shall be no more than 3 in. (74 mm) wide, and extend no more than 3 in. (75 mm) past the edges of the flatjack. It shall be deep enough that the flatjack may be inserted 3 in. (75 mm) beyond the lowest point on the rock fact adjacent to the slot. If drilled, care shall be taken that the holes are straight and parallel to keep the bottom of the slot open to receive the jack. The slot shall be washed clean of all dirt and cuttings, using clean water.

7.5 *Relaxation Measurements*—Deformation shall be measured immediately upon completion of slot cutting and again immediately prior to testing. If the rock undergoes strain under

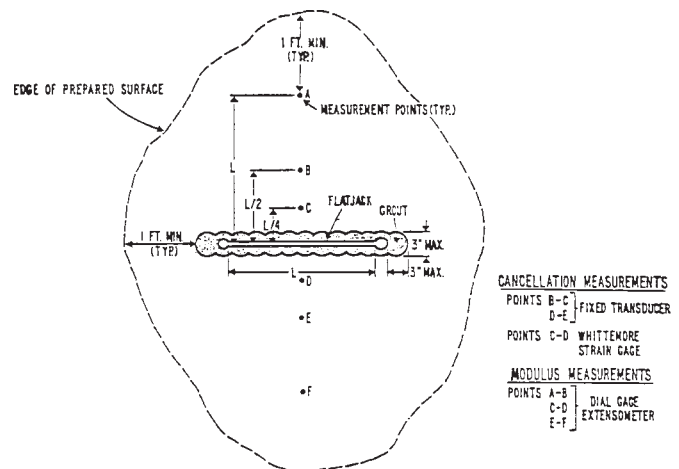

FIG. 1 Recommended Flatjack Measurement Array, Surface Measurements

TABLE 1 Ratio of Skin Stress to Cancellation Pressure for 1-m Square (1.09-yd Square) Flatjack²

Distance from slot	Poisson's ratio of rock			
	0.10	0.20	0.33	0.50
0	0.99	0.99	0.98	0.92
0.1 L ^A	0.98	0.98	0.94	0.89
0.2 L	1.00	0.98	0.93	0.88
0.3 L	1.04	1.01	0.98	0.93
0.4 L	1.10	1.08	1.02	1.01
0.5 L	1.20	1.17	1.11	1.08
0.6 L	1.31	1.27	1.24	1.18
0.7 L	1.44	1.39	1.37	1.30
0.8 L	1.58	1.52	1.48	1.38
0.9 L	1.71	1.69	1.61	1.46
1.0 L	1.87	1.83	1.73	1.53

^AL = width of flatjack.

different from jacks nearly this size. Field experience indicates that this table cannot be used to correct cancellation pressures directly, but only as an indication of where to locate the cancellation measuring points to minimize error. In practice, skin stress measurements are made close enough to the slot that they may be assumed to equal the cancellation pressure within an acceptable error.

8.2.2 When deformation is measured between points on opposite sides of the flatjack slot, elastic theory and deformation are used to calculate skin stress. Alexander³ assumed that the deformations due to cutting the slot were similar to the deformations caused by a finite elliptical opening in a uniformly loaded elastic plate, and the deformations caused by the jack were similar to those caused by an infinitely thin elliptical opening the length of the jack. The deformation on one side of the jack, due to cutting the slot, W , is given by the following equations:

$$W_o = \left[\frac{SC}{E} (1 - \nu) \left(1 + \frac{Y^2}{C^2} \right)^{1/2} \right] - \left[\frac{Y}{C} + (1 + \nu) / \left(1 + \frac{Y^2}{C^2} \right)^{1/2} \right] \quad (1)$$

$$W_1 = \left[\frac{SY_o}{E} (-2\nu) \left(1 + \frac{Y^2}{C^2} \right)^{1/2} \right] - \left[\frac{Y}{C} + (1 + \nu) / \left(1 + \frac{Y^2}{C^2} \right)^{1/2} \right] \quad (2)$$

$$W_2 = W_1 \frac{Q}{S} \quad (3)$$

$$W = W_o = W_1 + W_2 \quad (4)$$

where:

- W_o = displacement on one side of the slot during cutting of an infinitely thin slot, in. (mm),
- W_1 = displacement on one side of the slot due to finite slot width, in. (mm),
- W_2 = displacement on one side of the slot due to biaxial stress, in. (mm),
- S = rock stress normal to the jack, lbf/in.²(MPa),

- Q = rock stress parallel to the jack, lbf/in.² (MPa),
- C = half-length of the slot, in. (mm),
- Y = distance of measuring point from center line of jack, in. (mm),
- Y_o = half-width of slot, in. (mm),
- E = modulus of deformation of the rock mass lbf/in.² (GPa), and
- ν = Poisson's ratio of the rock mass.

The deformation caused by pressurizing the jack, W_j , is given by:

$$W_j = \left[\frac{PC_o}{E} (1 - \nu) \left(1 + \frac{Y^2}{C_o^2} \right)^{1/2} \right] - \left[\frac{Y}{C_o} + (1 - \nu) / \left(1 + \frac{Y^2}{C_o^2} \right)^{1/2} \right] \quad (5)$$

where:

- P = jack pressure, lbf/in.² (MPa), and
- C_o = half-length of jack, in. (mm).

At cancellation pressure:

$$W = \text{lbf/in.}^2 \text{ (MPa)} W_j \quad (6)$$

8.3 *Modulus of Deformation*—The modulus of deformation calculations again fall into two categories. When deformation is measured on one side of the slot, the modulus, E , is calculated using the following:⁴

$$E, \text{ lbf/in.}^2 \text{ (GPa)} = (PLR/2\pi\Delta Y) \quad (7)$$

where:

- P = pressure in flatjack, lbf/in.² (MPa),
- L = distance between measuring points, in. (mm),
- R = stress distribution factor, and
- ΔY = deformation between measuring points, in. (mm).

The stress distribution factor, R , is calculated as follows:

$$R = (A_q + \sin A_q) - (\nu (A_q + \sin A_q) + (A_z + \sin A_z) - \nu (A_z - \sin A_z)) \quad (8)$$

where:

- ν = Poisson's ratio of the rock, and
- A_q, A_z = angles, in radians, between the measuring points and the edges of the flatjack, as shown on Fig. 4

When deformation measurements are taken across the slot, Eq 5 above is rearranged to solve for the modulus, E :

$$E, \text{ lbf/in.}^2 \text{ (GPa)} = K(P/\Delta Y) \quad (9)$$

where:

- P = pressure in flatjack, lbf/in.² (MPa),
- ΔY = deformation between measuring points, in. (mm), and
- K = coefficient dependent on test geometry.

9. Report

9.1 The purpose of this section is to establish the minimum requirements for a complete and usable report. Further details may be added as appropriate and the order of items may be changed if necessary. Applications of the test results are

³ Alexander, L. G., "Field and Laboratory Tests in Rock Mechanics," *Third Australia—New Zealand Conference on Soil Mechanics and Foundation Engineering*, Sydney, Australia, 1960.

⁴ Dodds, D. J., *Flatjack Tests*, Foundation Sciences, Inc., Report to the Army Corps of Engineers, Missouri River District Laboratory, Portland, Oregon, 1969.

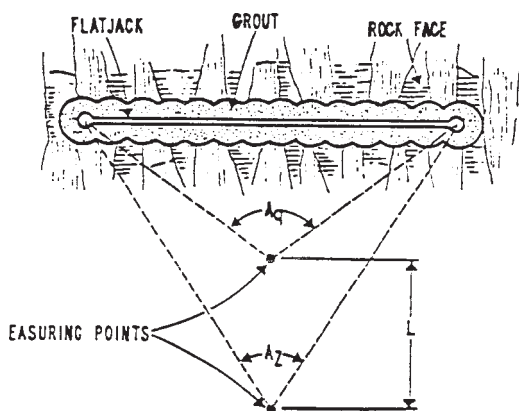

FIG. 4 Definition of Geometric Terms for Modulus Determination

beyond the scope of this procedure, but may be an integral part of some testing programs. In that case, an applications section compatible with the information described as follows should be included.

9.2 *Introductory Section of the Report*—The introductory section is intended to present the scope and purpose of the testing program and the characteristics of the materials tested.

9.2.1 *Scope of the Testing Program:*

9.2.1.1 *Location and Orientation*—The location and orientation of each flatjack shall be presented. A graphic presentation is recommended.

9.2.1.2 *Rationale for Test Location Selection*—The reasons for selecting individual test locations shall be discussed.⁵

9.2.1.3 *Limitations of the Testing Program*—The areas of interest that are not covered by the testing program and the limitations of the data within the areas of application shall be discussed in general terms.

9.2.2 *Brief Description of the Test Site Geology*—The geology of each test location shall be described including the rock type, fractures, alterations, inclusion, etc. A detailed geologic map of the test adit at the flatjack location showing the jack and measuring points is required.

9.3 *Test Method:*

9.3.1 *Equipment and Apparatus*—A detailed listing of the equipment actually used for the test shall be included in the report. The name, model number, and basic specifications of each major piece shall be listed.

9.3.2 *Procedure*—The procedure actually used for the test shall be listed in detailed steps.

9.3.3 *Variations*—If the actual equipment or procedure varies from the requirements contained in this procedure, each variation and the reasons for it shall be noted. The effect of the variation upon the test results shall be discussed.

9.4 *Theoretical Background:*

9.4.1 *Data Reduction Equations*—All equations used to reduce the data shall be clearly presented and fully defined. Any assumptions inherent in the equations and any limitations in their applications shall be noted and their effects on the results discussed.

9.4.2 *Site-Specific Influences:*

9.4.2.1 *Assumptions*—The degree to which the actual test site conditions conform to the assumptions contained in the data reduction equations shall be discussed.

9.4.2.2 *Correction Factors*—Any factors or methods applied to the data to correct for a nonideal situation shall be fully explained.

9.5 *Results:*

9.5.1 *Summary of Results*—A table including rock types, orientations, average cancellation pressures and skin stress values, average modulus of deformation values, ranges, and uncertainties shall be presented.

9.5.2 *Individual Results*—A table including test numbers, rock types, orientations, relaxation deformation, cancellation pressure, skin stress, and modulus of deformation values should be presented.

9.5.3 *Graphics*—Typical pressure versus deformation curves for each rock type shall be presented.

9.5.4 *Other*—The following other types of data analyses and presentations may be included, as appropriate:

9.5.4.1 Histogram of results,

9.5.4.2 Comparison of results to results from other types of in situ tests,

9.5.4.3 Estimate of undisturbed stress levels, and

9.5.4.4 Comparison of results to other studies.

9.6 *Error Estimate*—The results shall be analyzed using standard statistical methods. All uncertainties shall be calculated using a 95 %, confidence interval.

9.6.1 *Measurement Error*—The error associated with a single test shall be evaluated. This includes the combined effects of all pressure and deformation measurements.

9.6.2 *Rock Mass Variability*—For each suite of similar tests, the mean modulus of deformation, the range, standard deviation, and 95 % confidence limits for the mean shall be calculated, as a minimum.

9.6.3 *Group Correlation*—When appropriate, the means of groups shall be compared to determine whether the observed differences between groups are significant at the 95 % confidence level.

9.7 *Appended Data:*

9.7.1 *Pressure versus Deformation Curves*—A pressure versus deformation curve for each test shall be included in an appendix.

9.7.2 *Data Sheets*—A completed form (Fig. 2 and Fig. 3) for each test shall be included in an appendix.

10. Precision and Bias

10.1 Due to the nature of the rock materials tested by this method it is either not feasible or too costly at this time to produce multiple specimens which have uniform physical properties. Any variation observed on the data is just as likely to be due to specimen variation as to operator or laboratory testing variation. Subcommittee D18.12 welcomes proposals that would allow for development of a valid precision statement. There is no accepted reference value of rock for this test method, therefore, bias cannot be determined.

⁵ Panek, L. A., and Stock, J. A., "Development of a Rock Stress Monitoring Station Based on the Flat Slot Method of Measuring Existing Rock Stress," Bureau of Mines Report of Investigation 6537, Department of the Interior, Washington, DC, 1964.

11. Keywords

11.1 creep; flatjack hydraulic pressure; in situ stress;
modulus of deformation

ASTM International takes no position respecting the validity of any patent rights asserted in connection with any item mentioned in this standard. Users of this standard are expressly advised that determination of the validity of any such patent rights, and the risk of infringement of such rights, are entirely their own responsibility.

This standard is subject to revision at any time by the responsible technical committee and must be reviewed every five years and if not revised, either reapproved or withdrawn. Your comments are invited either for revision of this standard or for additional standards and should be addressed to ASTM International Headquarters. Your comments will receive careful consideration at a meeting of the responsible technical committee, which you may attend. If you feel that your comments have not received a fair hearing you should make your views known to the ASTM Committee on Standards, at the address shown below.

This standard is copyrighted by ASTM International, 100 Barr Harbor Drive, PO Box C700, West Conshohocken, PA 19428-2959, United States. Individual reprints (single or multiple copies) of this standard may be obtained by contacting ASTM at the above address or at 610-832-9585 (phone), 610-832-9555 (fax), or service@astm.org (e-mail); or through the ASTM website (www.astm.org).