



Designation: D 5311 – 92 (Reapproved 1996)

## Standard Test Method for Load Controlled Cyclic Triaxial Strength of Soil<sup>1</sup>

This standard is issued under the fixed designation D 5311; the number immediately following the designation indicates the year of original adoption or, in the case of revision, the year of last revision. A number in parentheses indicates the year of last reapproval. A superscript epsilon ( $\epsilon$ ) indicates an editorial change since the last revision or reapproval.

### 1. Scope

1.1 This test method covers the determination of the cyclic strength (sometimes called the liquefaction potential) of saturated soils in either undisturbed or reconstituted states by the load-controlled cyclic triaxial technique.

1.2 The cyclic strength of a soil is evaluated relative to a number of factors, including: the development of axial strain, magnitude of applied cyclic stress, number of cycles of stress application, development of excess pore-water pressure, and state of effective stress. A comprehensive review of factors affecting cyclic triaxial test results is contained in the literature (1).<sup>2</sup>

1.3 Cyclic triaxial strength tests are conducted under undrained conditions to simulate essentially undrained field conditions during earthquake or other cyclic loading.

1.4 Cyclic triaxial strength tests are destructive. Failure may be defined on the basis of the number of stress cycles required to reach a limiting strain or 100 % pore pressure ratio. See Section 3 for Terminology.

1.5 This test method is generally applicable for testing cohesionless free draining soils of relatively high permeability. When testing well-graded materials, silts, or clays, it should be recognized that pore-water pressures monitored at the specimen ends do not in general represent pore-water pressure values throughout the specimen. However, this test method may be followed when testing most soil types if care is taken to ensure that problem soils receive special consideration when tested and when test results are evaluated.

1.6 There are certain limitations inherent in using cyclic triaxial tests to simulate the stress and strain conditions of a soil element in the field during an earthquake.

1.6.1 Nonuniform stress conditions within the test specimen are imposed by the specimen end platens. This can cause a redistribution of void ratio within the specimen during the test.

1.6.2 A 90° change in the direction of the major principal stress occurs during the two halves of the loading cycle on isotropically consolidated specimens.

1.6.3 The maximum cyclic shear stress that can be applied to the specimen is controlled by the stress conditions at the end of consolidation and the pore-water pressures generated during testing. For an isotropically consolidated contractive (volume decreasing) specimen tested in cyclic compression, the maximum cyclic shear stress that can be applied to the specimen is equal to one-half of the initial total axial pressure. Since cohesionless soils are not capable of taking tension, cyclic shear stresses greater than this value tend to lift the top platen from the soil specimen. Also, as the pore-water pressure increases during tests performed on isotropically consolidated specimens, the effective confining pressure is reduced, contributing to the tendency of the specimen to neck during the extension portion of the load cycle, invalidating test results beyond that point.

1.6.4 While it is advised that the best possible undisturbed specimens be obtained for cyclic strength testing, it is sometimes necessary to reconstitute soil specimens. It has been shown that different methods of reconstituting specimens to the same density may result in significantly different cyclic strengths. Also, undisturbed specimens will almost always be stronger than reconstituted specimens.

1.6.5 The interaction between the specimen, membrane, and confining fluid has an influence on cyclic behavior. Membrane compliance effects cannot be readily accounted for in the test procedure or in interpretation of test results. Changes in pore-water pressure can cause changes in membrane penetration in specimens of cohesionless soils. These changes can significantly influence the test results.

1.6.6 The mean total confining pressure is asymmetric during the compression and extension stress application when the chamber pressure is constant. This is totally different from the symmetric stress in the simple shear case of the level ground liquefaction.

1.7 The values stated in both inch-pound and SI units are to be regarded separately as the standard. The values given in parentheses are for information only.

<sup>1</sup> This test method is under the jurisdiction of ASTM Committee D-18 on Soil and Rock and is the direct responsibility of Subcommittee D18.09 on Dynamic Properties of Soils.

Current edition approved Oct. 15, 1992. Published January 1993.

<sup>2</sup> The **boldface** numbers in parentheses refer to a list of references at the end of the text.

1.8 This standard does not purport to address all of the safety concerns, if any, associated with its use. It is the responsibility of the user of this standard to establish appropriate safety and health practices and determine the applicability of regulatory limitations prior to use.

## 2. Referenced Documents

### 2.1 ASTM Standards:

- D 422 Test Method for Particle-Size Analysis of Soils<sup>3</sup>
- D 653 Terminology Relating to Soil, Rock, and Contained Fluids<sup>3</sup>
- D 854 Test Method for Specific Gravity of Soils<sup>3</sup>
- D 1587 Practice for Thin-Walled Tube Sampling of Soils<sup>3</sup>
- D 2216 Test Method for Laboratory Determination of Water (Moisture) Content of Soil and Rock<sup>3</sup>
- D 2850 Test Method for Unconsolidated, Undrained Compressive Strength of Cohesive Soils in Triaxial Compression<sup>3</sup>
- D 4220 Practice for Preserving and Transporting Soil Samples<sup>3</sup>
- D 4253 Test Methods for Maximum Index Density and Unit Weight of Soils Using a Vibratory Table<sup>3</sup>
- D 4254 Test Method for Minimum Index Density and Unit Weight of Soils and Calculation of Relative Density<sup>3</sup>
- D 4318 Test Method for Liquid Limit, Plastic Limit, and Plasticity Index of Soils<sup>3</sup>
- D 4767 Test Method for Consolidated-Undrained Triaxial Compression Test on Cohesive Soils<sup>3</sup>

## 3. Terminology

### 3.1 Definitions:

3.1.1 Definitions for terms used in this test method (including *liquefaction*) are in accordance with Terminology D 653. Additional descriptions of terms are defined in 3.2 and in 10.2 and Fig. 1.

### 3.2 Definitions of Terms Specific to This Standard:

3.2.1 *full or 100 % pore pressure ratio*— a condition in which  $\Delta u$  equals  $\sigma'_{3c}$ .

3.2.2 *peak pore pressure ratio*—the maximum pore pressure ratio measured during a particular loading sequence.

3.2.3 *peak (single amplitude) strain*—the maximum axial strain (from the origin or initial step) in either compression or extension produced during a particular loading sequence.

3.2.4 *peak to peak (double amplitude) strain*— the difference between the maximum axial strain in compression and extension during a given cycle under cyclic loading conditions.

3.2.5 *pore pressure ratio*—the ratio, expressed as a percentage, of the change of excess pore-water pressure,  $\Delta u$ , to the effective minor principal stress,  $\sigma'_{3c}$ , at the end of primary consolidation.

## 4. Summary of Test Method

4.1 A cylindrical soil specimen is sealed in a watertight rubber membrane and confined in a triaxial chamber where it is subjected to a confining pressure. An axial load is applied to the top of the specimen by a load rod.

4.2 Specimens are consolidated isotropically (equal axial and radial stress). Tubing connections to the top and bottom specimen platens permit flow of water during saturation, consolidation and measurement of pore-water pressure during cyclic loading.

4.3 Following saturation and consolidation, the specimen is subjected to a sinusoidally varying axial load by means of the load rod connected to the specimen top platen. The cyclic load, specimen axial deformation, and porewater pressure development with time are monitored.

4.4 The test is conducted under undrained conditions to approximate essentially undrained field conditions during earthquake or other dynamic loading. The cyclic loading generally causes an increase in the pore-water pressure in the specimen, resulting in a decrease in the effective stress and an increase in the cyclic axial deformation of the specimen.

4.5 Failure may be defined as when the peak excess pore-water pressure equals the initial effective confining pressure, full or 100 % pore pressure ratio (sometimes called initial liquefaction), or in terms of a limiting cyclic strain or permanent strain.

## 5. Significance and Use

5.1 Cyclic triaxial strength test results are used for evaluating the ability of a soil to resist the shear stresses induced in a soil mass due to earthquake or other cyclic loading.

5.1.1 Cyclic triaxial strength tests may be performed at different values of effective confining pressure on isotropically consolidated specimens to provide data required for estimating the cyclic stability of a soil.

5.1.2 Cyclic triaxial strength tests may be performed at a single effective confining pressure, usually equal to 14.5 lb/in.  $2(100 \text{ kN/m}^2)$ , or alternate pressures as appropriate on isotropically consolidated specimens to compare cyclic strength results for a particular soil type with that of other soils, Ref (2).

5.2 The cyclic triaxial test is a commonly used technique for determining cyclic soil strength.

5.3 Cyclic strength depends upon many factors, including density, confining pressure, applied cyclic shear stress, stress history, grain structure, age of soil deposit, specimen preparation procedure, and the frequency, uniformity, and shape of the

<sup>3</sup> Annual Book of ASTM Standards, Vol 04.08.

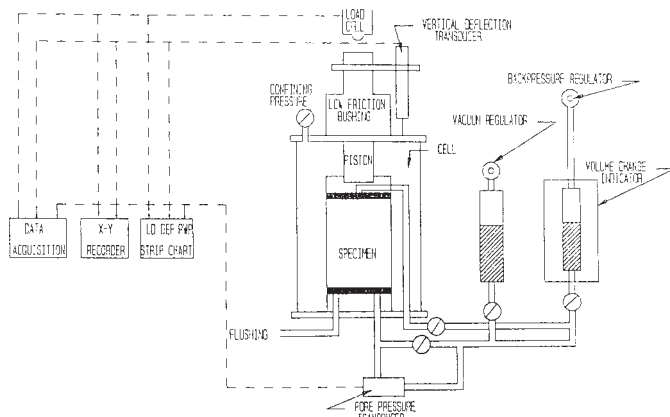

**FIG. 1 Schematic Representation of Load-Controlled Cyclic Triaxial Strength Test Equipment**

cyclic wave form. Thus, close attention must be given to testing details and equipment.

**6. Apparatus**

6.1 In many ways, triaxial equipment suitable for cyclic triaxial strength tests is similar to equipment used for the unconsolidated-undrained triaxial compression test (see Test Method D 2850) and the consolidated-undrained triaxial compression test (see Test Method D 4767). However, there are special features described in the following subsections that are required to perform acceptable cyclic triaxial tests. A schematic representation of a typical load-controlled cyclic triaxial strength test set-up is shown in Fig. 1.

6.2 *Triaxial Compression Cell*—The primary considerations in selecting the cell are tolerances for the piston, top cap, and low friction piston seal.

6.2.1 Two linear ball bushings or similar bearings should be used to guide the load rod to minimize friction and to maintain alignment.

6.2.2 The load rod diameter should be large enough to minimize lateral bending. A minimum load rod diameter of 1/6 the specimen diameter has been used successfully in many laboratories.

6.2.3 The load rod seal is a critical element in triaxial cell design for cyclic soils testing. The seal must exert negligible friction on the load rod. The maximum acceptable piston friction tolerable without applying load corrections is commonly considered to be ± 2 % of the maximum single amplitude cyclic load applied in the test. The use of an air bushing as proposed in Ref (3) will meet or exceed these requirements.

6.2.4 Top and bottom platen alignment is critical if premature specimen failure caused by the application of a nonuniform state of stress to the specimen is to be avoided. Internal tie-rod triaxial cells that allow for adjustment of alignment before placement of the chamber have been found to work well at a number of laboratories. These cells allow the placement of the cell wall after the specimen is in place between the loading platens. Acceptable limits of platen eccentricity and parallelism are shown in Fig. 2.

6.2.5 Since in cyclic triaxial tests extension as well as compression loads may be exerted on the specimen, the load rod shall be connected to the top platen by straight threads backed by a shoulder on the piston that tightens up against the platen.

6.2.6 There shall be provision for specimen drainage at both the top and bottom platens.

6.2.7 *Porous Discs*—The specimen shall be separated from the specimen cap and base by rigid porous discs of a diameter equal to that of the specimen. The coefficient of permeability of the discs shall be approximately equal to that of fine sand ( $3.9 \times 10^{-5}$  in./s [ $1 \times 10^{-4}$  cm/s]). The discs shall be regularly checked to determine whether they have become clogged.

6.3 Dynamic loading equipment used for load-controlled cyclic triaxial tests shall be capable of applying a uniform sinusoidal load at a frequency range of 0.1 to 2.0 Hz. The frequency of 1.0 Hz is preferred. The loading device shall be

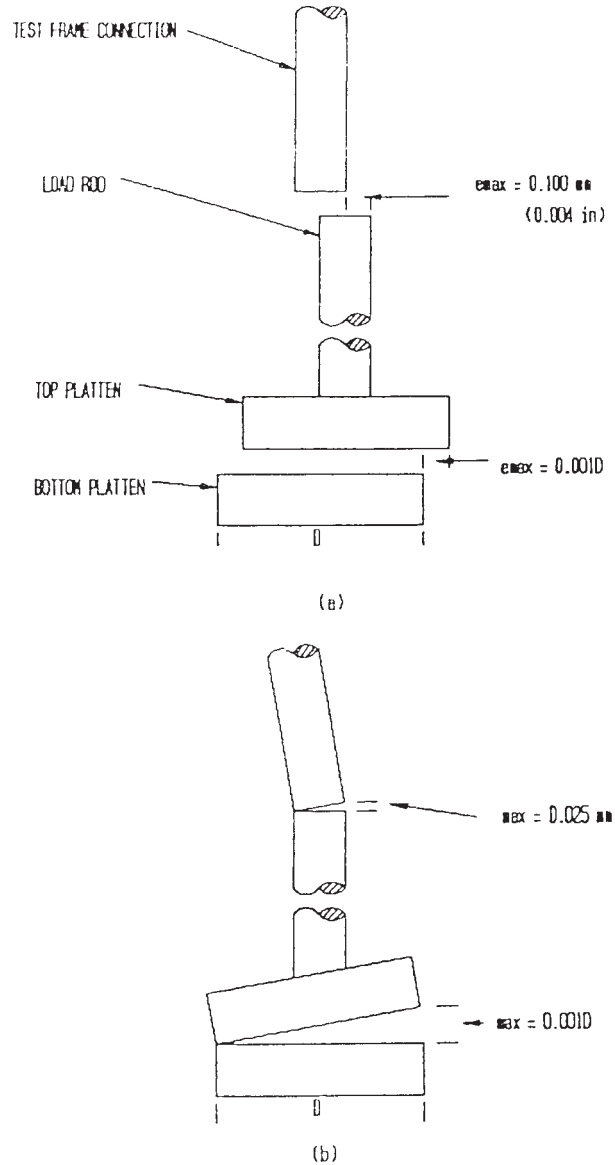

NOTE 1—(a) Eccentricity and (b) parallelism.  
**FIG. 2 Limits on Acceptable Platen and Load Rod Alignment**

able to maintain uniform cyclic loadings to at least 20 % peak-to-peak strains. Unsymmetrical compression-extension load peaks, nonuniformity of pulse duration, “ringing,” or load fall-off at large strains shall not exceed tolerance illustrated in Fig. 3. The equipment shall also be able to apply the cyclic load about an initial static load on the loading rod. Evaluate uniformity of the load trace into the failure state to ensure that load uniformity criteria presented in previous sections are achieved. Show this in an appropriate way by calculating the percent load drift ( $P_{error}$ ) between the maximum load ( $\Delta P_{max}$ ) based on the initial loading cycle and the measured load in the  $n$ th cycle as follows:

$$\Delta P_{max} = (\Delta P_c + \Delta P_e)_{max} \tag{1}$$

$$P_{error} = \frac{[(\Delta P_c + \Delta P_e)_{max} - (\Delta P_c + \Delta P_e)_n] \times 100}{(\Delta P_c + \Delta P_e)_{max}}$$

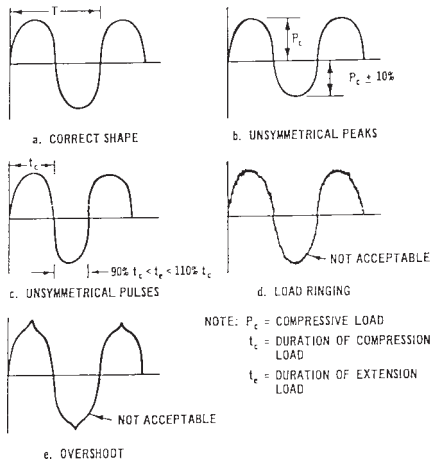

**FIG. 3 Examples of Acceptable and Unacceptable Sinusoidal Loading Wave Forms for Cyclic Triaxial Strength Tests**

$P_{error}$  should be < 5 % at axial strains of  $\pm 5$  %.

where:

- $\Delta P_{max}$  = maximum load,
- $\Delta P_c$  = change in peak applied load in compression,
- $\Delta P_e$  = change in peak applied load in extension, and
- $P_{error}$  = percent load drift.

NOTE 1—For less than 20 cycles for samples with high fines content non-uniform pore pressure distribution may result.

6.4 Recording Equipment—Load, displacement, and pore water pressure transducers are required to monitor specimen behavior during cyclic loading; provisions for monitoring the chamber pressure during loading are optional (see Table 1).

6.4.1 Axial Load Measurement—The desired maximum cyclic load-measuring device may be a load ring, electronic load cell, hydraulic load cell, or any other load-measuring device capable of measuring the axial load to an accuracy of within  $\pm$

1 % of the axial load. Generally, the load cell capacity should be no greater than five times the total maximum load applied to the test specimen to ensure that the necessary measurement accuracy is achieved. The minimum performance characteristics of the load cell are presented in Table 1.

6.4.2 Axial Deformation Measurement— Displacement measuring devices such as linear variable differential transformer (LVDT), potentiometer-type deformation transducers, and eddy current sensors may be used if they have an accuracy of  $\pm 0.02$  % of the initial specimen height (see Table 1). Accurate deformation measurements require that the transducer be properly mounted to avoid excessive mechanical system compression between the load frame, the triaxial cell, the load cell, and the loading piston.

6.4.3 Pore-Water Pressure Transducer— The specimen pore-water pressure shall be measured to within  $\pm 0.25$  psi (2 kPa). During cyclic loading the pore-water pressure shall be measured in such a manner that as little water as possible is allowed to go into or out of the specimen. To achieve this requirement for cyclic loading, a very stiff electronic pressure transducer must be used. The measuring device shall have a compliance of all the assembled parts of the pore-water pressure measurement system relative to the total volume of the specimen satisfying the following requirement:

$$\frac{\Delta V/V}{\Delta u} < 2.2 \times 10^{-5} \text{ in.}^2/\text{lb (or } 3.2 \times 10^{-6} \text{ m}^2/\text{kN)} \quad (2)$$

where:

- $\Delta V$  = change in volume of the pore-water measurement system due to a pore pressure change, in.<sup>3</sup>(m<sup>3</sup>),
- $V$  = the total volume of the specimen, in.<sup>3</sup>(m<sup>3</sup>), and
- $\Delta u$  = the change in pore pressure, psi (kPa).

The pore-water pressures shall be measured using the drainage line(s) leading to either (or both) the specimen cap or base.

**TABLE 1 Data Acquisition**

Minimum Response Characteristics for Cyclic Triaxial Strength Tests

1. Analog Recorders:

Recording speeds: 0.5 to 50 cm/s (0.2 to 20 in./s) system accuracy (including linearity and hysteresis): 0.5 %<sup>A</sup> frequency response: 100 Hz

2. Digital Recorders:

Minimum sampling rate: 40 data points per cycle

3. Measurement Transducers:

	Load Cell	Displacement Transducer (LVDT) <sup>B</sup>	Pore Pressure
Minimum sensitivity, mV/V	2	0.2 mV/0.025 mm/V (0.2 mV/0.001 in./V) (AC LVDT) 5 mV/0.025 mm/V (5 mV/0.001 in./V) (DC LVDT)	2
Nonlinearity, % full scale	$\pm$	$\pm 0.25$	$\pm 0.5$
Hysteresis, % full scale	$\pm 0.25$	0.0	$\pm 0.5$
Repeatability, % full scale	$\pm 0.10$	$\pm 0.01$	$\pm 0.5$
Thermal effects on zero shift or sensitivity %of full scale/°C (°F)	$\pm 0.005$ ( $\pm 0.025$ )	...	$\pm 0.02$ ( $\pm 0.01$ )
Maximum deflection at full rated value in mm (in.)	0.125 (0.005)	...	...
Volume change characteristics, cm <sup>3</sup> /kPa (cu in./psi)	...	...	$< 2.4 \times 10^{-4}$ ( $< 1.0 \times 10^{-4}$ )

<sup>A</sup> System frequency response, sensitivity, and linearity are functions of the electronic system interfacing, the performance of the signal conditioning system used, and other factors. It is therefore a necessity to check and calibrate the above parameters as a total system and not on a component basis.

<sup>B</sup> LVDT's, unlike strain gages, cannot be supplied with meaningful calibration data. System sensitivity is a function of excitation frequency, cable loading, amplifier phase characteristics, and other factors. It is necessary to calibrate each LVDT-cable-instrument system after installation, using a known input standard.

6.4.4 *Recorders*—Specimen behavior is evaluated from continuous time records of applied load, axial deformation, and change in pore-water pressure. Fast recording system response is essential if specimen performance is to be monitored accurately when failure conditions are approached. Required response characteristics are given in Table 1. Resolution of each variable should be better than 2 % of the maximum value being measured.

6.4.5 *Volume Change Measurement Device*—The volume of water entering or leaving the specimen shall be measured with an accuracy of within  $\pm 0.05$  % of the total volume of the specimen. The volume measuring device is usually a burette but may be any other device meeting the accuracy requirement. The device must be able to withstand the maximum chamber pressure.

6.5 *Valves*—Changes in volume due to opening and closing valves may result in inaccurate volume change and pore-water pressure measurements. For this reason, valves in the specimen drainage system shall be of the type that produce minimum volume changes due to their operation. A valve may be assumed to produce minimum volume change if opening or closing the valve in a closed, saturated pore-water pressure system does not induce a pressure change of greater than  $\pm 0.1$  psi (0.7 kPa). All valves must be capable of withstanding applied pressures without leakage.

NOTE 2—Ball valves have been found to provide minimum volume change characteristics; however, any other type of valve having suitable volume change characteristics may be used.

6.6 *Weighing Device*—The specimen weighing device shall determine the mass of the specimen to an accuracy of within  $\pm 0.05$  % of the total mass of the specimen.

6.7 *Water Deaeration Device*—The amount of dissolved gas (air) in the water used to saturate the specimen may be decreased by boiling, by heating and spraying into a vacuum, or by any other method that will satisfy the requirement for saturating the specimen within the limits imposed by the available maximum back pressure and time to perform the test.

6.8 *Testing Environment*—The consolidation and shear portion of the test shall be performed in an environment where temperature fluctuations are less than  $\pm 7.2^\circ\text{F}$  ( $\pm 4^\circ\text{C}$ ) and there is no direct contact with sunlight.

6.9 *Miscellaneous Apparatus*—Specimen trimming and carving tools including a wire saw, steel straightedge, miter box, and vertical trimming lath, apparatus for preparing compacted specimens, membrane and O-ring expander, water content cans, and data sheets shall be provided as required.

## 7. Sampling

7.1 Take special care in sampling and transporting samples to be used for cyclic triaxial tests as the quality of the results diminishes greatly with sample disturbance. Method D 1587 and Practices D 4220 cover procedures and apparatus that may be used to obtain satisfactory samples for testing.

## 8. Specimen Preparation

8.1 Specimens shall be cylindrical and have a minimum diameter of 51 mm (2.0 in.). The height-to-diameter ratio shall be between 2.0 and 2.5. The largest particle size shall be

smaller than  $\frac{1}{6}$  the specimen diameter. If, after completion of a test, visual observation finds that oversize particles are present, an appropriate statement should be made in the report of test data under remarks.

8.2 Trim undisturbed specimens for testing in any manner that minimizes sample disturbance, minimizes changes in the sampled density of the specimen, and minimizes changes in the initial water content. No matter what trimming method is used, take extreme care to ensure that the specimen ends are flat and parallel. A procedure that has been shown to achieve these criteria for frozen specimens of clean sands (GP, SP-SM) is as follows:

8.2.1 If a milling machine is available, cut the sample tube lengthwise at two diametrically opposite places (see Note 3), using a rapid feed, and then cut into sections with an electric hacksaw. If a milling machine is not used, cut the desired section with an electric hacksaw or a tube cutter with stiffening collars. Then clean the cut ends of the tube of burrs, and push the specimen from the tube. Trim the ends of the specimen smooth and perpendicular to the length using a miter box. Take care to ensure that the specimen remains frozen during the trimming operation. Place the specimen in the triaxial chamber and enclose it in a rubber membrane. Apply a partial vacuum of 5 psi (35 kPa) to the specimen and measure the specimen diameter and height according to the method given in 9.2 to calculate the initial volume of the specimen. After the specimen has thawed, remeasure the specimen to determine specimen conditions immediately before saturation. Volume change during thawing indicates that inadequate sampling or specimen preparation techniques may have been used.

NOTE 3—Do not cut entire length of tube.

8.2.2 *Undisturbed Specimens*—Prepare undisturbed specimens from large undisturbed samples or from samples secured in accordance with Method D 1587 or other acceptable undisturbed tube sampling procedures and preserved and transported in accordance with the practices for Group C and Group D samples as appropriate in Practices D 4220. Specimens obtained by tube sampling may be tested without trimming except for cutting the end surfaces plane and perpendicular to the longitudinal axis of the specimen, provided soil characteristics are such that no significant disturbance results from sampling. Handle specimens carefully to minimize disturbance, changes in cross section, or change in water content. Samples must be capable of standing on their own. If compression or any type of noticeable disturbance would be caused by the extrusion device, split the sample tube lengthwise or cut the tube in suitable sections to facilitate removal of the specimen with minimum disturbance. Prepare trimmed specimens, in an environment such as a controlled high-humidity room where soil water content change is minimized.

### 8.3 Reconstituted Specimens:

NOTE 4—Method of specimen reconstitution greatly affects test results.

8.3.1 There are a number of methods for reconstituting specimens. One of the following methods may be used. The method used must be specified in test report.

8.3.2 *Pouring Method (Alternative)*—For this specimen preparation technique, saturate the soil initially in a container,

pour through water into a water-filled forming mold, and then densify to the required density by vibration (4).

8.3.3 *Dry or Moist Vibration Method (Alternative)*—In this procedure, compact oven dry, air dry, or moist material in lifts (typically six to seven layers) in a membrane lined split mold attached to the bottom platen of the triaxial cell. Compact the preweighed material for each lift by vibration to the dry unit weight required to obtain the prescribed density. The soil surface should be scarified between lifts. It should be noted that to obtain layers having equal densities, the bottom layers have to be slightly undercompacted (5), since compaction of each succeeding layer densifies the sand in layers below it. After the last layer is partially compacted, put the top cap in place and continue vibration until the desired dry unit weight is obtained.

8.3.4 *Tamping Method (Alternative)*—For this procedure (5), tamp air dried or moist soil in layers into a mold. The only difference between the tamping method is that each layer is compacted by hand tamping with a compaction foot instead of with a vibrator.

8.3.5 After the specimen has been formed, place the specimen cap in place and seal the specimen with O-rings or rubber bands after rolling the membrane ends over the cap and base. Then apply a partial vacuum of  $\leq 35$  kPa (5 psi) to the specimen and remove the forming jacket. If the test confining pressure is greater than 103 kPa (14.7 psi), apply a full vacuum to the specimen before removing the jacket. Application of large vacuum can cause large volume changes of the specimen. The specimen volume should be measured before and after vacuum application to check for this occurrence.

## 9. Procedure

9.1 Because of the wide variety of triaxial equipment presently in use for cyclic soil testing, it is not possible to prescribe a step-by-step testing procedure that is compatible with the characteristics of all equipment. The following procedures, however, will be common to any cyclic triaxial strength test on saturated specimens.

9.2 *Specimen Measurement*—Because density greatly influences the cyclic triaxial strength, it is imperative that accurate density determination and volume change measurements be made during saturation and consolidation. Base the initial specimen conditions on measurements taken after the mold is removed (with the specimen under vacuum). Take diameter measurements using a circumferential measuring tape<sup>4</sup> to the nearest 0.025 mm (0.001 in.). Take height measurements using calipers or similar measurement equipment, to the nearest 0.025 mm (0.001 in.) at four locations, and measure masses to the nearest 0.01 g for specimens 63.5 mm (2.5 in.) or less in diameter and 0.1 g for specimens having diameters greater than 63.5 mm. Determine water contents taken of specimen trimmings to within 0.1 % (see Test Method D 2216).

9.3 *Saturation*—The objective of the saturation phase of the test is to fill all voids in the specimen with water without undesirable prestressing of the specimen or allowing the specimen to swell (unless the specimen will swell under the desired effective consolidation stress). Saturation is usually

accomplished by applying back pressure to the specimen pore-water to drive air into solution after either: applying vacuum to the specimen and dry drainage system (lines, porous discs, pore-pressure device, filter-strips or cage, and discs) and allowing deaired water to saturate the system while maintaining the vacuum; or saturating the drainage system by boiling the porous discs in water and allowing water to flow through the system before mounting the specimen. It should be noted that time is required to place air into solution. Accordingly, removing as much air as possible before applying back pressure will decrease the amount of air that will have to be placed into solution and will also decrease the back pressure required for saturation. In addition, air remaining in the specimen and drainage system just prior to applying back pressure will go into solution much more readily if the deaired water is used for saturation. The use of deaired water will also decrease the time and back pressure required for saturation. Many procedures have been developed to accomplish saturation. The following are suggested procedures:

9.3.1 *Starting with Initially Dry Drainage System*—Increase the 5 psi (35 kPa) partial vacuum acting on top of the specimen to the maximum available vacuum. If the effective consolidation stress under which the strength is to be determined is less than the maximum partial vacuum, apply a lower partial vacuum to the chamber. The difference between the partial vacuum applied to the specimen and the chamber pressure should never exceed the effective consolidation stress for the test and should never be less than 5 psi (35 kPa). After approximately 2 h (see Note 5), allow deaired water to percolate from the bottom to the top of the specimen under a differential vacuum of less than 3 psi (20 kPa) (see Note 6).

NOTE 5—For specimens of cohesive soils, time under the maximum available vacuum may have to be decreased to avoid effects due to drying resulting from sublimation.

9.3.1.1 There should always be a positive effective stress of at least 2 psi (13 kPa) at the bottom of the specimen during this part of the procedure. When water appears in the burette connected to the top of the specimen, close the valve to the bottom of the specimen and fill the burette with deaired water. Next, reduce the vacuum acting on top of the specimen through the burette to atmospheric pressure while simultaneously increasing the chamber pressure by an equal amount. During this process, the difference between the pore pressure measured at the bottom of the specimen and the chamber pressure should not be allowed to exceed the desired effective consolidation pressure. When the pore pressure at the bottom of the specimen stabilizes, proceed with back pressuring of the specimen pore-water as described in 9.3.3. To check for equalization, close the drainage valves to the specimen and measure the pore pressure change over a 1-min interval. If the change is less than 1 % of the chamber pressure, the pore pressure may be assumed to be stabilized.

9.3.1.2 In cases where the vacuum is limited, CO<sub>2</sub> can be allowed to seep slowly upward from the bottom of the specimen, while the specimen is being formed or after it has been confined in the triaxial chamber. The CO<sub>2</sub> will displace

<sup>4</sup> Available from PI Tape, Box 398, Lemon Grove, CA 92045.

the air in the specimen and, being much more soluble in water than air, will enable subsequent saturation steps to be carried out successfully.

NOTE 6—For saturated clays, percolation may not be necessary and water can be added simultaneously at both top and bottom.

**9.3.2 Starting with Initially Saturated Drainage System—**After filling the burette connected to the top of the specimen with deaired water, apply a chamber pressure of 5 psi (35 kPa) or less and open the specimen drainage valves. When the pore pressure at the bottom of the specimen stabilizes, according to the method described in 9.3.1, or when the burette reading stabilizes, initiate back-pressuring of the specimen pore-water.

**9.3.3 Applying Back Pressure—**Simultaneously increase the chamber and back pressure in steps with specimen drainage valves open so that deaired water from the burette connected to the top and bottom of the specimen may flow into the specimen. To avoid undesirable prestressing of the specimen while applying back pressure, the pressures must be applied incrementally with adequate time between increments to permit equalization of pore-water pressure throughout the specimen. The size of each increment might be 5 psi (35 kPa), 10 psi (70 kPa), or even 20 psi (140 kPa), depending on the compressibility of the soil specimen, the magnitude of the desired effective consolidation stress, and the degree of saturation of the specimen just before the addition of the increment. The difference between the chamber pressure and the back pressure during back pressuring should not exceed 5 psi (35 kPa) unless it is deemed necessary to control swelling of the specimen during the procedure. The differences between the chamber and back pressure must also remain within  $\pm 5\%$  when the pressures are raised and within  $\pm 2\%$  when the pressures are constant. To check for equalization after application of a back pressure increment or after the full value of back pressure has been applied, close the specimen drainage valves and measure the change in pore-pressure over a 1 min interval. If the change in pore pressure is less than 1 % of the difference between the chamber pressure and the back pressure, add another back pressure increment or take a measurement of the Pore Pressure Parameter B (Section 9.3.4) to determine if saturation is completed. Specimens shall be considered saturated if the value of B is equal to or greater than 0.95, or if B remains unchanged with addition of back pressure increments.

NOTE 7—The total back pressure required to saturate a compacted specimen may be as high as 200 psi (1400 kPa) if the wet mounting method is used.

NOTE 8—Many laboratories use differential pressure regulators and transducers to achieve the requirements for small differences between chamber and back pressure.

**9.3.4 Measurement of the Pore-Pressure Parameter B—**The Pore-Pressure Parameter B is defined by the following equation:

$$B = \Delta u / \Delta \sigma_3 \quad (3)$$

where:

$\Delta u$  = the change in the specimen pore-water pressure that occurs as a result of a change in the chamber pressure when the specimen drainage valves are closed, and

$\Delta \sigma_3$  = the change in the chamber pressure at the location where it exits the chamber.

The B-value shall be determined as follows:

9.3.4.1 Close the specimen drainage valves and increase the chamber pressure 10 psi (70 kPa).

9.3.4.2 Determine and record the maximum value of the induced pore-water pressure. For many specimens, the pore pressure may decrease after the immediate response and then increase slightly with time. If this occurs, plot values of  $\Delta u$  with time and the asymptotic pore pressure to compute the change in pore-water pressure. A large increase in  $\Delta u$  with time or values of  $\Delta u$  greater than  $\Delta \sigma_3$  indicate a leak of chamber fluid into the specimen or pore-water pressure measuring system. Decreasing values of  $\Delta u$  with time may indicate a leak in that part of the pore-water pressure measurement system located outside the chamber.

9.3.4.3 Calculate the B-value using the equation given in 9.3.4.

9.3.4.4 Reapply the same effective confining pressure (chamber pressure minus back pressure) as existed prior to the B-value check by reducing the chamber pressure by 10 psi (70 kPa) or by alternatively increasing the back pressure by 10 psi (70 kPa). If the B-value is continuing to increase with increasing back pressure, proceed with back pressure saturation. If the B-value is equal to or greater than 0.95 or if the B-value versus back pressure plot indicates no further increase in B-value with increasing back pressure, initiate consolidation.

9.3.4.5 During the saturation process, measure the change in height of the specimen to the nearest 0.025 mm (0.001 in.). In addition, during saturation apply an axial load to the piston (that is screwed into the top cap) to compensate for the uplift force on the load rod so that the specimen is maintained in an isotropic or other known state of stress. Calculate the static load to maintain an isotropic condition from the following equation:

$$P_s = \sigma_3 A_r \text{, minus the weight of load rod and top platen} \quad (4)$$

where:

$P_s$  = the static piston correction load,

$\sigma_3$  = the cell pressure, and

$A_r$  = the cross sectional area of the load rod.

#### 9.4 Consolidation:

9.4.1 Isotropically consolidate the specimen.

9.4.2 Isotropic consolidation is defined as the state where the vertical effective consolidation stress ( $\sigma'_{1c}$ ) is equal to the lateral effective consolidation stress ( $\sigma'_{3c}$ ). To consolidate the specimen isotropically, maintain the applied back pressure constant and increase the chamber pressure until the difference between the chamber pressure and the back pressure equals the desired consolidation pressure. Apply an axial load to counter-balance uplift due to increasing the chamber pressure. This may require incrementally applying the consolidation pressure

to provide sufficient time to apply and adjust the counterbalancing uplift load. Measure changes in specimen height during consolidation to the nearest 0.025 mm (0.001 in.), and the change in specimen volume to the nearest 0.1 mL.

9.4.3 Following consolidation, close the drainage valves and observe the pore-water pressure for a period of time to verify that no leaks in the membrane or pore-water pressure system have occurred. If the time for consolidation exceeds 8 h, redetermine the B value prior to cyclic loading.

**9.5 Cyclic Loading:**

9.5.1 Estimate the magnitude of cyclic load to be applied for the desired stress ratio, SR, with the following equation:

$$P_c = 2 \times \sigma'_{3c} \times SR \times A_c \quad (5)$$

where:

- $P_c$  = estimated cyclic load to be applied to the specimen,
- $\sigma'_{3c}$  = consolidation pressure (chamber pressure minus back pressure),
- SR = desired stress ratio  $[\Delta\sigma_a]/[2\sigma'_c]$ , and
- $A_c$  = area of specimen after consolidation.

9.5.2 If it does not already exist, form a large air pocket at the top of the triaxial chamber by draining water from the cell without allowing the cell pressure to drop. The air pocket is required so that piston movement in and out of the chamber during cyclic loading does not create chamber pressure fluctuations. Do not allow water level to drop below the top of the specimen.

9.5.3 Close drainage valves to the specimen and cyclically load the specimen with the first half cycle in compression using a 0.1 to 2 Hz sinusoidal load form where the stress varies between peak compression and peak extension values. During cyclic loading keep the cell pressure constant and record the axial load, axial deformation, and change in pore-water pressure with time.

9.5.4 The load is cycled with the first stress wave being applied in compression.

9.5.5 The load is cycled until either cyclic double amplitude vertical strain exceeds 20 %, the single amplitude strain in either extension or compression exceeds 20 %, 500 load cycles or the number of load cycles required in the testing program are exceeded, or the load wave form deteriorates beyond acceptable values.

NOTE 9—Gilbert (4) has found that above 5 % double amplitude strain in sands a large density redistribution may be observed that makes the results questionable.

9.6 *Specimen Removal*—Following cyclic testing, carefully remove the specimen from the triaxial cell so no particles are lost, then dry and determine the mass for dry unit weight calculations.

**10. Calculation**

10.1 To evaluate the test data obtained from the individual cyclic triaxial strength test, it is first necessary to convert the time history of load and deformation to cyclic stress and strain and to reduce the time history of pore-water pressure to a convenient form.

10.2 Calculate the cyclic stress, strain and pore-water pressure ratio defined in Fig. 4 using the following relationships:

$$\begin{aligned} \sigma_c &= P_c/A_c \\ \sigma_e &= P_e/A_c \\ \sigma_a &= (\sigma_c + \sigma_e)/2 \end{aligned}$$

and:

$$\begin{aligned} \epsilon_c &= \delta_c/H_c \\ \epsilon_e &= \delta_e/H_c \\ \epsilon_{da} &= \epsilon_c + \epsilon_e \\ U &= u_{max}/\sigma'_{3c} \text{ isotropic} \end{aligned}$$

where:

- $\sigma_c$  =  $P_c/A_c$  = peak cyclic stress in compression,
- $\sigma_e$  =  $P_e/A_c$  = peak cyclic stress in extension,
- $P_c$  = change in peak applied load in compression,
- $P_e$  = change in peak applied load in extension,
- $A_c$  =  $V_c/H_c$  = area of the specimen after consolidation (mean consolidated area),
- $j_a$  = average single amplitude cyclic axial stress,
- $\pm\sigma_{dc}$  = average single amplitude cyclic deviator stress,
- $\epsilon_c$  = axial strain in compression,
- $\epsilon_e$  = axial strain in extension,
- $\delta_c$  = cyclic axial deformation in compression,
- $\delta_e$  = cyclic axial deformation in extension,
- $H_c$  = height of the specimen after consolidation,
- $\epsilon_{da}$  = double amplitude axial strain, percent,
- $U$  = cyclic pore-water pressure ratio,
- $u_{max}$  = maximum excess pore-water pressure induced during a cycle, and
- $\sigma'_{3c}$  = effective isotropic consolidation stress.

10.3 Tabulate discrete values of load, deformation, and pore-water pressure for different cycles of interest and calculate the resulting values of stress, strain, and pore-water pressure ratio for each cycle. Note that values of stress and

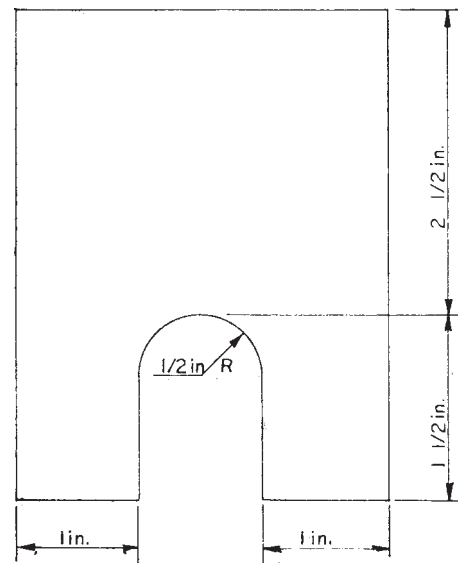

**FIG. 4 Definition of Measured Load-Deformation Values and Calculated Stress Strain Values for Cyclic Triaxial Strength Tests**

strain are calculated based on consolidated specimen dimensions. Evaluate uniformity of the load trace into the failure state to ensure that load uniformity criteria presented in previous sections are achieved. Show this in an appropriate way by calculating the percent load drift ( $P_{error}$ ) using the equation in 6.3.

## 11. Report

11.1 Present sufficient reference data for each test to define adequately the type of testing equipment used, the characteristics of the triaxial cell and pore-water pressure monitoring system, as well as the load repetition rate and load wave form characteristics, and specimen preparation method. Reference information required for each test (or for the test series if the testing procedures are kept constant) is presented in Table 2.

11.2 The time histories or tabular data presentation of Table 3 may be used to plot any of the following curves that have been found to be useful in evaluating results from individual tests:

- 11.2.1  $\epsilon_{da}$  versus number of cycles ( $N$ ),
- 11.2.2  $\epsilon_c$  versus  $N$ ,
- 11.2.3  $\epsilon_e$  versus  $N$ ,
- 11.2.4  $\Delta\sigma_a$  versus  $N$ ,
- 11.2.5  $\Delta\sigma_c$  versus  $N$ ,
- 11.2.6  $\Delta\sigma_e$  versus  $N$ ,
- 11.2.7  $\Delta u$  versus  $N$ ,
- 11.2.8  $U$  versus  $N$ ,

**TABLE 2 Specimen Information Required for Each Test**

1.	Project name
2.	Boring and sample number
3.	Soil classification and description
4.	Index properties (grain size curve, Atterberg limits, and specific gravity as a minimum, maximum and minimum densities when available)
5.	Specimen preparation technique used
6.	Initial and consolidated diameter, area, and height
7.	Initial and consolidated water content
8.	Initial and consolidated dry unit weight
9.	Initial and consolidated relative density (when required)
10.	Consolidation stresses ( $\sigma_{1e}$ and $\sigma_{3c}$ )
11.	Degree of saturation ( $B$ values)
12.	Labeled time history trace of load, deformation, and pore-water pressure

11.2.9  $\sigma_{3(\min)}/\sigma_{3c}$  versus  $N$ , and

11.2.10  $P_{error}$  versus  $N$ .

11.2.11 In most cases, Plots 1, 4, 8 and 10 will be adequate to define specimen behavior in cyclic triaxial strength tests.

11.3 In reporting results of a series of cyclic strength tests for isotropically consolidated specimens, the number of cycles required for a specimen to reach various values of double amplitude axial strain are often plotted versus the cyclic stress ratio ( $SR$ ):

$$SR = \frac{\sigma_a}{2\sigma_{3c}} \quad (6)$$

In this way it is possible to normalize strength values of specimens at a given density tested at a number of confining pressures. However, values of the cyclic stress ratio ( $SR$ ) for each loading cycle, shown in Column 8 of Table 3, are not as meaningful as some form of average value that presents, as a weighted average, the cyclic stress ratio applied in previous cycles. Calculate such an average stress ratio as follows:

$$SR_{ave} = (1/m)\sum SR_n \quad (n = 1, m) \quad (7)$$

where  $SR_{ave}$  is the average cyclic stress ratio up to cycle  $m$  and  $SR_n$  is the cyclic stress ratio in the  $n$ th cycle. For each cyclic strength test, the average cyclic stress ratio for initial liquefaction and for double amplitude strain values of 2.5, 5, 10 and 20 % shall be tabulated as shown in Table 4. Such data from tests on the same material at the same density may be combined and plotted as  $SR$  versus  $N$  values, which are commonly called cyclic triaxial test strength curves.  $SR_{ave}$  is needed only when  $P_{error}$  occurs with straining.

## 12. Precision and Bias

12.1 The variability of soil and resultant inability to determine a true reference value prevents development of a meaningful statement of bias. Data are being evaluated to determine the precision of this test method. In addition, the subcommittee is seeking pertinent data from users of this test method.

## 13. Keywords

13.1 consolidated-undrained tests; cohesionless soils; laboratory tests; liquefaction; triaxial tests

**TABLE 3 Typical Table of Dynamic Triaxial Strength Results**

(1) Cycle Number	(2) Maximum Excess Pore Water Pressure	(3) Pore Pressure Ratio	(4) Cyclic Stress	(5) Average Cyclic Vertical Stress
	$\Delta u_{max}$	$U = \frac{\Delta u_{max}}{\sigma'_{3c}}$	Compression $\Delta\sigma_c$ Extension $\Delta\sigma_e$	$\Delta\sigma_a$
(6) Cyclic Vertical Strain	(7) Double Amplitude Vertical Strain	(8) Cyclic Stress Ratio	(9) Average Stress Ratio To This Cycle	
Compression $\epsilon_c$ Tension $\epsilon_e$	$\epsilon_{da}$	$SR = \frac{\Delta\sigma_a}{2\sigma'_c}$	$SR_{ave}$	
	(10) Percent Difference from Programmed Load		(11) Observed Performance	
	$\Delta P_{error}$		(uniform straining, necking, etc.)	

**TABLE 4 Typical Cyclic Triaxial Soil Strength Values Required to Evaluate the Results of a Dynamic Test Series**

Average Cyclic Stress Ratio	Number of Cycles to Initial Liquefaction	Number of Cycles to Develop a Double Amplitude Axial Strain of			
		0.5 %	5 %	10 %	20 %

## REFERENCES

- (1) Chan, C. K., "Low Friction Seal System," *Journal of Geotechnical Engineering Division*, ASCE, Vol 101, GT4, Sept. 1975.
- (2) Silver, M. L., Chan, C. K., Ladd, R. S., Lee, K. L., Tiedmann, D. A., Townsend, F. C., Valera, J. E., and Wilson, J. H., "Cyclic Triaxial Strength of Standard Test Sand," *Journal of the Geotechnical Engineering Division*, ASCE, Vol 102, GT5, May, 1976.
- (3) Chaney, R., and Mullis, J., "Wet Sample Preparation Techniques," ASTM, *Geotechnical Testing Journal*, Vol 1, No. 2, June, 1978.
- (4) Gilbert, P., "Investigation of Density Variation in Triaxial Test Specimens of Cohesionless Soil Subjected to Cyclic and Monotonic Loading," Tech. Rept. GL-84-10, USA/COE, 1984.
- (5) Ladd, R. S., "Preparing Test Specimens Using Undercompaction," ASTM, *Geotechnical Testing Journal*, ASTM, Vol 1, No. 1, 1978.

*The American Society for Testing and Materials takes no position respecting the validity of any patent rights asserted in connection with any item mentioned in this standard. Users of this standard are expressly advised that determination of the validity of any such patent rights, and the risk of infringement of such rights, are entirely their own responsibility.*

*This standard is subject to revision at any time by the responsible technical committee and must be reviewed every five years and if not revised, either reapproved or withdrawn. Your comments are invited either for revision of this standard or for additional standards and should be addressed to ASTM Headquarters. Your comments will receive careful consideration at a meeting of the responsible technical committee, which you may attend. If you feel that your comments have not received a fair hearing you should make your views known to the ASTM Committee on Standards, 100 Barr Harbor Drive, West Conshohocken, PA 19428.*