



Designation: D 559 — 96 — 03

# Standard Test Methods for Wetting and Drying Compacted Soil-Cement Mixtures <sup>1</sup>

This standard is issued under the fixed designation D 559; the number immediately following the designation indicates the year of original adoption or, in the case of revision, the year of last revision. A number in parentheses indicates the year of last reapproval. A superscript epsilon ( $\epsilon$ ) indicates an editorial change since the last revision or reapproval.

*This standard has been approved for use by agencies of the Department of Defense.*

## 1. Scope \*

1.1 These test methods cover procedures for determining the soil-cement losses, water content changes, and volume changes (swell and shrinkage) produced by repeated wetting and drying of hardened soil-cement specimens. The specimens are compacted in a mold, before cement hydration, to maximum density at optimum water content using the compaction procedure described in Test Methods D 558.

1.2 Two test methods, depending on soil gradation, are covered for preparation of material for molding specimens and for molding specimens as follows:

	Sections
<i>Test Method A</i> , using soil material passing a No. 4 (4.75-mm) sieve. This method shall be used when 100 % of the soil sample passes the No. 4 (4.75-mm) sieve .....	5
<i>Test Method A</i> , using soil material passing a No. 4 (4.75-mm) sieve. This method shall be used when 100 % of the soil sample passes the No. 4 (4.75-mm) sieve .....	7
<i>Test Method B</i> , using soil material passing a 3/4-in. (19.0-mm) sieve. This method shall be used when part of the soil sample is retained on the No. 4 (4.75-mm) sieve. This test method may be used only on materials with 30 % or less retained on the 3/4-in. (19.0-mm) sieve. ....	6
<i>Test Method B</i> , using soil material passing a 3/4-in. (19.0-mm) sieve. This method shall be used when part of the soil sample is retained on the No. 4 (4.75-mm) sieve. This test method may be used only on materials with 30 % or less retained on the 3/4-in. (19.0-mm) sieve. ....	8

1.3 ~~Th~~All observed and calculated values shall conform to the guidelines for significant digits and rounding established in Practice D 6026.

1.4 The values stated in inch-pound units are to be regarded as the standard, except as noted below. The SI units values given in parentheses are mathematical conversions to SI units, and are provided for information only and are not considered standard.

1.4.1 The gravitational system of inch-pound units is used when dealing with inch-pound units. In this system, the pound (lbf) represents a unit of force (weight), while the unit for mass is slugs.

1.4.2 The slug unit of mass is almost never used in commercial practice (density, scales, balances, etc.). Therefore, the standard unit for mass in this standard is either kilogram (kg) or gram (g) or both. Also, the equivalent inch-pound unit (slug) is not given.

1.4.3 It is common practice in the engineering/construction profession to use pounds to represent both a unit of mass (lbm) and of force (lbf). This implicitly combines two separate systems of units; that is, the absolute system and the gravitational system. It is scientifically undesirable to combine the use of two separate sets of inch-pound units within a single standard. As stated in 1.4.2, this standard includes the gravitational system of inch-pound units and does not use/present the slug unit for mass. However, the use of balances or scales recording pounds of mass (lbm) or recording density in lbm/ft<sup>3</sup> shall not be regarded as nonconformance with this standard.

1.5 *This standard does not purport to address all of the safety concerns, if any, associated with its use. It is the responsibility of the user of this standard to establish appropriate safety and health practices and determine the applicability of regulatory limitations prior to use.*

<sup>1</sup> These test methods are under the jurisdiction of the ASTM Committee D-18 on Soil and Rock and are the direct responsibility of Subcommittee D18.15 on Stabilization of Additives.

Current edition approved May 10, 1996. Published July 1996. Originally published as D 559 — 39, approved in 1939. Last previous edition approved in 1996 as D 559 — 89 $\epsilon$ .

\*A Summary of Changes section appears at the end of this standard.

## 2. Referenced Documents

### 2.1 *ASTM Standards:*

C 150 Specification for Portland Cement<sup>2</sup>

C 595 Specification for Blended Hydraulic Cements<sup>2</sup>

D 558 Test Methods for Moisture-Density Relations of Soil-Cement Mixtures<sup>3</sup>

D 560 Test Methods for Freezing-and-Thawing Tests of Compacted Soil-Cement Mixtures<sup>3</sup>

D 653 Terminology Relating to Soil, Rock, and Contained Fluids<sup>3</sup>

D 2168 Test Methods for Calibration of Laboratory Mechanical-Rammer Soil Compactors<sup>3</sup>

~~D 3740 Practice 2216 Test Method for Laboratory Determination of Water (Moisture) Content of Soil and Rock by Mass<sup>3</sup>~~

D 3740 Practice for the Minimum Requirements for Agencies Engaged in the Testing and/or Inspection of Soil and Rock as Used in Engineering Design and Construction<sup>3</sup>

D 4753 Specification of Evaluating, Selecting, and Specifying Balances and Scales for Use in Soil, Rock, and Construction Material Testing<sup>3</sup>

D 6026 Practice for Using Significant Digits in Geotechnical Data<sup>4</sup>

E 11 Specification for Wire-Cloth and Sieves for Testing Purposes<sup>5</sup>

E 145 Specifications for Gravity-Convection and Forced-Ventilation Ovens<sup>6</sup>

## 3. Terminology

3.1 For common definitions of terms used in this standard, refer to Terminology D 653.

## 4. Significance and Use

34.1 These test methods are used to determine the resistance of compacted soil-cement specimens to repeated wetting and drying. These test methods were developed to be used in conjunction with Test Methods D 560 and criteria given in the *Soil-Cement Laboratory Handbook*<sup>7</sup> to determine the minimum amount of cement required in soil-cement to achieve a degree of hardness adequate to resist field weathering.

~~NOTE 1—The agency performing these test methods can be evaluated in accordance with Practice D 3740. Notwithstanding statements on precision and bias contained in these test methods, the precision quality of these test methods the result produced by this standard is dependent on the competence of the personnel performing it, and the suitability of the equipment and facilities used. Agencies that meet the criteria of Practice D 3740 are generally considered capable of competent and objective testing/sampling/inspection/etc. Users of these test methods this standard are cautioned that compliance with Practice D 3740 does not, in itself, ensure reliable testing results. Reliable testing depends results depend on many factors; Practice D 3740 provides a means of evaluating some of these factors.~~

## 45. Apparatus

45.1 *Mold*—A cylindrical metal mold having a capacity volume of  $\frac{1}{30} \pm 0.00040$  ft<sup>3</sup> ( $944 \pm 11$  cm<sup>3</sup>) with an internal diameter of  $4.0 \pm 0.016$  in. ( $101.60 \pm 0.41$  mm) and conforming to Fig. 1 to permit preparing compacted specimens of soil-cement mixtures of this size. The mold shall be provided with a detachable collar assembly approximately 2½-in. (63.5 mm) in height. The mold may be of the split type consisting of two half-round sections or a section of pipe with one side split perpendicular to the pipe circumference and that can be securely locked in place to form a closed cylinder having the dimensions described above. The mold and collar assembly shall be so constructed that it can be fastened firmly to a detachable base.

### 45.2 *Rammer:*

45.2.1 *Manual Rammer*—A manually operated metal rammer having a  $2.000 \pm 0.005$ -in. ( $50.80 \pm 0.13$ -mm) diameter circular face and ~~weighing 5.5 a mass of 2.49 ± 0.02 lb (2.49 ± 0.01 kg).~~ The rammer shall be equipped with a suitable guidesleeve to control the height of drop to a free fall of  $12.0 \pm \frac{1}{16}$  in. ( $304.8 \pm 1.6$  mm) above the elevation of the soil-cement. The guidesleeve shall have at least four vent holes not smaller than  $\frac{3}{8}$  in. (9.5 mm) spaced 90° apart and located with centers  $\frac{3}{4} \pm \frac{1}{16}$  in. ( $19.0 \pm 1.6$  mm) from each end and shall provide sufficient clearance that freefalls of the rammer shaft and head will not be restricted.

45.2.2 *Mechanical Rammer*—A mechanically operated metal rammer having a  $2.000 \pm 0.005$ -in. ( $50.80 \pm 0.13$ -mm) diameter face and a manufactured ~~weight mass of 5.5~~  $2.49 \pm 0.02$  lb ( $2.49 \pm 0.01$  kg). The operating ~~weight mass~~ of the rammer shall be determined from a calibration in accordance with Methods D 2168. The rammer shall be equipped with a suitable arrangement to control the height of drop to a free-fall of  $12.0 \pm \frac{1}{16}$  in. ( $304.8 \pm 1.6$  mm) above the elevation of the soil-cement.

45.2.3 *Rammer Face*—Strength and resistance to wetting-and-drying of specimens compacted with the sector face rammer may differ from that of specimens compacted with the circular face rammer. Therefore, the sector face rammer shall not be used unless previous tests on like soil-cement mixtures show that similar resistance to wetting and drying is obtained with the two types of rammers.

<sup>2</sup> *Annual Book of ASTM Standards, Vols 04.01 and 04.02, Vol 04.01.*

<sup>3</sup> *Annual Book of ASTM Standards, Vol 04.08.*

<sup>4</sup> *Annual Book of ASTM Standards, Vols 04.01, 04.06, and 14.02, Vol 04.09.*

<sup>5</sup> *Soil-Cement Laboratory Handbook Annual Book of ASTM Standards, Portland Cement Assn., 1971, Vol 14.02.*

<sup>6</sup> *Annual Book of ASTM Standards, Vol 14.04.*

<sup>7</sup> *Soil-Cement Laboratory Handbook, Portland Cement Assn., 1971.*

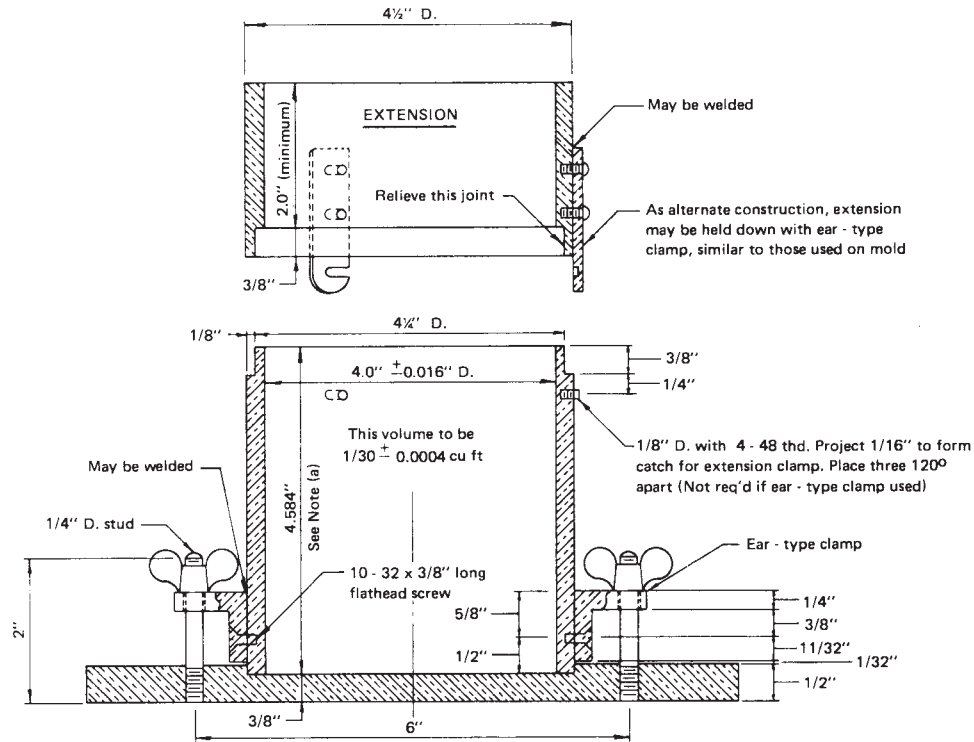

Metric Equivalents

in.	mm
0.016	0.41
0.026	0.66
1/32	0.80
1/16	1.6
1/8	3.2
1/4	6.4
11/32	8.7
3/8	9.5
1/2	12.7
5/8	15.9
2	50.8
2 1/2	63.5
4	101.6
4 1/4	108.0
4 1/2	114.3
4.584	116.43
6	152.4
6 1/2	165.1
8	203.2
ft <sup>3</sup>	cm
1/30	944
0.004	11
1/13 333	2124
0.0009	25

NOTE 1—The tolerance on the height is governed by the allowable volume and diameter tolerances.

NOTE 2—The methods shown for attaching the extension collar to the mold and the mold to the base plate are recommended. However, others methods are acceptable, providing the attachments are equally as rigid as those shown.

FIG. 1 Cylindrical Mold

4.5.3 *Sample Extruder*—A jack, lever frame, or other device adapted for the purpose of extruding compacted specimens from the mold. Not required when a split-type mold is used.

4.5.4 *Balances*—A balance or scale of at least 25-lb (11.3-kg) capacity sensitive conforming to 0.01-lb (0.005-kg) and the requirements of Class GP5 with a readability of 1g in Specification D 4753, except that a Class GP2 balance of at least 1000-g capacity sensitive to 0.1 g.

4.5- 0.1g readability is required for water content determination.

5.5 *Drying Ovens*—A thermostatically controlled, preferably forced-draft type, meeting the requirements of Specification

E 145 and capable of maintaining a uniform temperatures of  $230 \pm 9^{\circ}\text{F}$  ( $110 \pm 5^{\circ}\text{C}$ )  $110 \pm 5^{\circ}\text{C}$  ( $230 \pm 9^{\circ}\text{F}$ ) throughout the chamber for drying the water content samples, specimens, and a thermostatically controlled drying oven capable temperature of maintaining temperatures of  $160 \pm 5^{\circ}\text{F}$  ( $71 \pm 3^{\circ}\text{C}$ )  $71 \pm 3^{\circ}\text{C}$  ( $160 \pm 5^{\circ}\text{F}$ ) throughout the drying chamber for drying compacted soil-cement specimens.

45.6 Moist Room—A moist room or suitable covered container capable of maintaining a temperature of  $70 \pm 3^{\circ}\text{F}$  ( $21 \pm 1.7^{\circ}\text{C}$ ) and a relative humidity of 100 % for 7-day storage of compacted specimens.

45.7 Water Bath—Suitable tank for submerging compacted specimens in water at room temperature.

45.8 Wire Scratch Brush—A wire scratch brush made of 2 by  $\frac{1}{16}$ -in. (50.800 by 1.588-mm) flat No. 26 gage (0.46-mm) wire bristles assembled in 50 groups of 10 bristles each and mounted to form 5 longitudinal rows and 10 transverse rows of bristles on a  $7\frac{1}{2}$  by  $2\frac{1}{2}$ -in. (190.0 by 63.5-mm) hardwood block.

45.9 Straightedge—A rigid steel stiff metal straightedge ~~12 in. (305 mm) in~~ of any convenient length but not less than 10-in. (250-mm). The total length of the straightedge shall be machined straight to a tolerance of  $\pm 0.005$ -in ( $\pm 0.1$ -mm). The scraping edge shall be beveled, if it is thickedger than  $\frac{1}{8}$ -in (3-mm).

45.10 Sieves—3-in. (75-mm),  $\frac{3}{4}$ -in. (19.0-mm), and No. 4 (4.75-mm) sieves conforming to the requirements of Specification E 11.

45.11 Mixing Tools—Miscellaneous tools such as mixing pan, and trowel, or a suitable mechanical device for thoroughly mixing the soil with cement and water.

45.12 Butcher Knife—A butcher knife approximately 10 in. (250 mm) in length for trimming the top of the specimens.

45.13 Scarifier—A six-pronged ice pick or similar apparatus to remove the smooth compaction plane at the top of the first and second layers of the specimen.

45.14 Container—A flat, round pan for moisture absorption by soil-cement mixtures, about 12 in. (305 mm) in diameter and 2 in. (50 mm) deep.

45.15 Measuring Device—A measuring device suitable for accurately measuring the heights and diameters of test specimens to the nearest 0.01 in. (0.20 mm).

45.16 Pans and Carriers—Suitable pans for handling materials and carriers or trays for handling test specimens.

45.17 Graduate—A graduated cylinder of 250-mL capacity for measuring water.

~~4.18 Moisture Cans~~

5.18 Water Content Containers—Suitable containers made of material resistant to corrosion and change in mass upon repeated heating, cooling, exposure to materials of varying pH, and cleaning. Unless a desiccator is used, containers with close fitting lids shall be used for testing specimens having a mass of about 200g; while for specimens having a mass greater than about 200g, containers without lids may be used. One container is needed for each water content determination.

## 6. Calibration

6.1 Perform calibrations before initial use, after repairs or other occurrences that might affect the test results, at intervals not exceeding 500 test specimens, or annually, whichever occurs first, for the following apparatus:

6.1.1 Balance—Evaluate in accordance with Specification D 3740.

6.1.2 Molds—Determine the volume as described in D 698, Annex 1.

6.1.3 Manual Rammer—Verify the free fall distance, rammer mass, and rammer force in accordance with Section 5.2. Verify the sleeve requirements in accordance with Section 5.2.1.

6.1.4 Mechanical Rammer—Calibrate and adjust the mechanical rammer in accordance with Test Method D 2168.

## 7. Test Method A—Using Soil Material Passing a No. 4 (4.75-mm) Sieve

57.1 Preparation of Material for Molding Specimens:

57.1.1 Prepare the soil sample in accordance with the procedure described in Test Method A of Test Methods D 558.

57.1.2 Select a sufficient quantity of the soil prepared as described in ~~5~~ 7.1.1 to provide two (Note 2) compacted specimens and required moisture samples.

NOTE 2—(Optional) Usually only one specimen (identified as No. 2) is required for routine testing. The other specimen (identified as No. 1) is made for research work and for testing unusual soils.

57.1.3 Add to the soil the required amount of cement conforming to Specification C 150 or Specification C 595. Mix the cement and soil thoroughly to a uniform color.

57.1.4 Add sufficient potable water to raise the soil-cement mixture to optimum water content at the time of compaction and mix thoroughly. When the soil used is a heavy textured clayey material, compact the mixture of soil, cement, and water in the container to a depth of about 2 in. (50 mm) using the rammer described in ~~4.2~~ 5.2 or a similar hand tamper, cover, and allow to stand for not less than 5 min but not more than 10 min to aid dispersion of the moisture and to permit more complete absorption by the soil-cement.

57.1.5 After the absorption period, thoroughly break up the mixture, without reducing the natural size of individual particles, until it will pass a No. 4 (4.75-mm) sieve, as judged by eye, and then remix.

57.2 Molding Specimens:

57.2.1 Form a specimen by immediately compacting the soil-cement mixture in the mold (with the collar attached) and later trimming the specimen in accordance with Test Method A of Test Methods D 558, and in addition scarify the tops of the first and second layers to remove smooth compaction planes before placing and compacting the succeeding layers. This scarification shall form grooves at right angles to each other, approximately 1/8 in. (3.2 mm) in width and 1/8 in. (3.2 mm) in depth and approximately 1/4 in. (6.4 mm) apart.

57.2.2 During compaction, take ~~from the batch~~ a representative sample of from the batch of soil-cement mixture, weighing not less than mixture that has a mass of at least, 100 g, weigh immediately, g. Determine and record the mass. Immediately, dry the specimen in an oven at 230 ± 9°F (110 ± 5°C) for at least 12 h or to a constant weight, mass. Determine and record the oven-dry mass of the specimen to four significant digits. Calculate the water content as prescribed in according to Test Methods ~~D 558 to~~ D 2216 and check against the design water content (Note 7).

57.2.3 ~~W~~Determine and record the mass of the compacted specimen to four significant digits and mold, remove the specimen it from the mold, and calculate mold. Calculate the oven-dry dry unit weight of each specimen in lbf/ft<sup>3</sup> (g/cm<sup>3</sup>) according to Test Method 558 to check against the design density.

5.2.4 Identify dry density (Note 7).

7.2.3.1 If the dry unit weight obtained is within the design tolerances specified, identify the specimen ~~on~~ with a metal tag (or other suitable device) as No. 1-~~(Note 2)~~ together with any other needed identification marks ~~a~~. This specimen will be used to obtain data on moisture water content and volume changes during the test.

57.2.53.2 If the dry unit weight obtained does not meet the tolerances specified, then another specimen will need to be compacted.

7.2.4 Form a second specimen as rapidly as possible and determine the ~~percentage of moisture water content~~ and oven-dry weight as described in ~~5 7.2.1-57.2.3~~. Identify this specimen as No. 2, together with other needed identification marks and use to obtain data on soil-cement losses during the test.

57.2.65 Determine the average diameter and height of the No. 1 specimen and calculate its volume.

57.2.76 Place the specimens on suitable carriers in the moist room and protect them from free water for a period of 7 days.

5.2.8 Weigh

7.2.7 Determine and record the mass and measurements of the No. 1 specimen at the end of the 7-day storage period to provide data for calculating its water content and volume.

NOTE 3—It is important that all height and diameter measurements be accurate to within 0.01 in. (0.2 mm) and be taken at the same points on the specimen at all times.

57.3 Procedure:

57.3.1 At the end of ~~the~~ storage in the moist room, submerge the specimens in potable water at room temperature for a period of 5 h and remove. ~~Weigh Determine and measure record the mass and measurements of the No. 1 specimen (volume (water content and moisture volume change specimen).~~

57.3.2 Place both specimens in an oven at 160°F (71°C) for 42 h and remove. ~~Weigh Determine and measure record the mass and measurements of the No. 1 specimen.~~

57.3.3 Give specimen No. 2 (soil-cement loss specimen) two firm strokes on all areas with the wire scratch brush. The brush shall be held with the long axis of the brush parallel to the longitudinal axis of the specimen or parallel to the ends as required to cover all areas of the specimen. Apply these strokes to the full height and width of the specimen with a firm stroke corresponding to approximately 3-lbf (13.3-N) force (Note 4). Eighteen to twenty vertical brush strokes are required to cover the sides of the specimen twice and four strokes are required on each end.

NOTE 4—This pressure is measured as follows: clamp a specimen in a vertical position on the edge of a platform scale and zero the scale. Apply vertical brushing strokes to the specimen and note the force necessary to register approximately 3 lbf (13.3 N).

57.3.4 The procedures described in ~~5 7.3.1-57.3.3~~ constitute one cycle (48 h) of wetting and drying. Again submerge the specimens in water and continue the procedure for 12 cycles.

NOTE ~~5~~ ~~Weight 5~~—Mass determinations of specimen No. 2 before and after brushing are usually made at the end of each cycle when conducting research and making special investigations.

57.3.5 The No. 1 specimen may be discontinued prior to 12 cycles should the measurements become inaccurate due to soil-cement loss of the specimen.

NOTE 6—If it is not possible to run the cycles continuously because of Sundays, holidays, or for any other reason, hold the specimens in the oven during the layover period if possible.

57.3.6 After 12 cycles of test, dry the specimens to constant ~~weight~~ mass at 230°F (110°C) and ~~weigh to determine and record the oven-dry weight mass~~ of the specimens.

57.3.7 The data collected will permit calculations of volume and water content changes of specimen No. 1 and the soil-cement losses of specimen No. 2 after the prescribed 12 cycles of test.

**68. Test Method B—Using Soil Material Passing a ¾-in. (19.0-mm) Sieve**

**68.1 Preparation of Material for Molding Specimens:**

68.1.1 Prepare the soil sample in accordance with Test Method B of Test Methods D 558.

68.1.2 Select and maintain separate representative samples of soil passing the No. 4 (4.75-mm) sieve and of saturated, surface-dry aggregate passing the ¾-in. (19.0-mm) sieve and retained on the No. 4 (4.75-mm) sieve so that the total sample will be enough to provide two (Note 1) 2) compacted specimens and required ~~moisture~~ water content samples. The percentage, by ~~oven-dry weight, mass,~~ of aggregate passing the ¾-in. (19.0-mm) sieve and retained on the No. 4 (4.75-mm) sieve shall be the same as the percentage passing the 3-in. (75-mm) sieve and retained on the No. 4 (4.75-mm) sieve in the original sample.

68.1.3 Add to the sample passing the No. 4 (4.75-mm) sieve, the amount of cement conforming to Specification C 150 or Specification C 595, required for the total sample specified in ~~6~~ 8.1.2. Mix the cement and soil thoroughly to a uniform color.

68.1.4 Add to the sample passing the No. 4 (4.75-mm) sieve, sufficient water to raise the total soil-cement mixture prescribed in ~~6~~ 8.1.2 to optimum ~~moisture~~ water content at time of compaction and facilitate moisture dispersion as described for Test Method A in ~~5~~ 7.1.4 to ~~5~~ 7.1.6.

68.1.5 After preparation of the mixture as described in ~~6~~ 8.1.1-68.1.4, add the saturated, surface-dry aggregate to the mixture and mix thoroughly.

**68.2 Molding Specimens:**

68.2.1 Form a specimen by immediately compacting the soil-cement mixture in the mold (with the collar attached) and later trimming the specimen in accordance with Test Method B of Test Methods D 558, and in addition as the mixture for each layer is placed in the mold, spade along the inside of the mold with a butcher knife before compaction to obtain uniform distribution of the material retained on the No. 4 (4.75-mm) sieve and scarify the tops of the first and second layers as described for Test Method A of this test method.

68.2.2 During compaction, take from the batch a representative sample of the soil-cement mixture ~~weighing not less than~~ with a mass of at least 500 g, ~~weigh~~ determine and record the moist mass immediately, and dry in an oven at 230 ± 9°F (110 ± 5°C) for at least 12 h or to constant ~~weight~~ mass to determine the water content to check against design ~~moisture~~ water content.

68.2.3 Form a second specimen as rapidly as possible in the same manner.

68.2.4 ~~W~~Determine and record the mass of each compacted specimen to check against design density, identify, measure the No. 1 specimen (Note 1), 2), place in the moist room, and measure the No. 1 specimen again at the end of the 7-day storage period as described for Test Method A in ~~5.2.3-5.2.8~~ 7.2.3-7.2.7 (Note ~~2~~ 3).

**68.3 Procedure:**

68.3.1 Proceed as directed in Test Method A (see ~~5~~ 7.3).

**79. Calculation**

79.1 Calculate the volume and water content changes and the soil-cement losses of the specimens as follows:

79.1.1 Calculate the difference between the volume of specimen No. 1 at the time of molding and subsequent volumes as a percentage of the original volume.

79.1.2 Calculate the water content of specimen No. 1 at the time of molding and subsequent water contents as a percentage of the original ~~oven-dry weight~~ mass of the specimen.

79.1.3 Correct the ~~oven-dry weight~~ mass of specimen No. 2 as obtained in ~~5~~ 7.3.6 for water that has reacted with the cement and soil during the test and is retained in the specimen at 230°F (110°C), as follows:

$$\text{Corrected oven-dry weight} = (A/B) \times 100 \tag{1}$$

$$\text{Corrected oven-dry mass} = (A/B) \times 100 \tag{1}$$

where:

*A* = ~~oven-dry weight~~ oven-dry mass after drying at 230°F (100°C), and

*B* = percentage of water retained in specimen plus 100.

The percentage of water retained in specimen No. 2 after drying at 110°C for use in the above formula can be assumed to be equal to the water retained in specimen No. 1. When No. 1 specimens are not molded, the foregoing data are not available and the average values prescribed in Table 1 are used.

**TABLE 1 Average Values**

AASHTO Soil Classification	Average Water Retained After Drying at 230°F (110°C), %
A-1, A-3	1.5
A-2	2.5
A-4, A-5	3.0
A-6, A-7	3.5

79.1.4 Calculate the soil-cement loss of specimen No. 2 as a percentage of the original oven-dry-weight mass of the specimen as follows:

$$\text{Soil-cement loss, \%} = (A/B) \times 100 \tag{2}$$

where:

A = original calculated oven-dry-weight mass minus final corrected oven-dry-weight, mass, and

B = original calculated oven-dry-weight, mass.

**810. Report**

810.1 The report shall include the following:

810.1.1 The designed optimum water content to the nearest 0.5 %, and maximum-density dry unit weight of the molded specimens to the nearest 0.5 lbf/ft<sup>3</sup>,

810.1.2 The water content and density dry unit weight obtained in molded specimens,

NOTE 7—Good 7—Unless otherwise specified, normal laboratory practice permits the following tolerances between design factors and those obtained in the molded specimens:

Moisture content	±1 percentage point
Density	±3 lb/ft <sup>3</sup> (0.048 g/cm <sup>3</sup> )
Water content	±1 percentage point
Dry Unit Weight	±3 lbf/ft <sup>3</sup>

810.1.3 The designed cement content, in percent, of the molded specimens,

810.1.4 The maximum volume change, in percent, and maximum water content during test of specimen No. 1, and

8.1.5 The 1,

10.1.5 The soil-cement loss, in percent, of specimen No. 2,

10.1.6 Sample identification (i.e., sample number, project, location, depth, etc.), and

10.1.7 Procedure used (Method A or Method B).

**911. Precision and Bias**

911.1 Precision—Only limited data are available from which to judge the variability of results for these test methods. These data are shown in Table 2.

911.1.1 A larger amount of weight mass loss data is listed under Test Methods D 560. It is expected that variations of results of these tests, Test Methods D 559, would be similar since the same brushing operation is used in both test methods to achieve the weight loss.

911.1.2 Experience indicates that the variations in test results are greater for high-weight mass losses and less for low-weight mass losses. The degree of variation of most interest is that at the allowable-weight mass loss criteria. Suggested allowable-weight mass loss criteria are given in the literature.

9.2-7

11.2 Bias—Since there is no accepted reference material suitable for determining the bias for the procedure for measuring weight loss, no statement on bias is being made.

**102. Keywords**

102.1 durability; soil-cement; soil-cement mixtures; soil stabilization; wet-dry

**TABLE 2 Weight Loss of Duplicate Specimens in Wetting and Drying Test<sup>A</sup>**

Soil No.	AASHTO Soil Class	Cement Content, %	Weight Losses of Duplicate Specimens, %
8939	A-1-b (0)	2	17, 19
		3	6, 0
		5	5, 1
8295	A-4 (5)	3	9, 11
		5	6, 2
		7	0, 0
		10	0, 2
8942	A-6 (10)	3	20, 25
		5	6, 7
		7	1, 1
		10	0, 0
9069	A-4 (8)	4	12, 12
		6	7, 6
		8	3, 3
		10	2, 2

<sup>A</sup> Molded from same batch by same operator. Data from Packard, R. G., "Alternate Methods for Measuring Freeze-Thaw and Wet-Dry Resistance of Soil-Cement Mixtures," *Highway Research Board Bulletin* No. 353, 1962.

## SUMMARY OF CHANGES

In accordance with Committee D 18 policy, this section identifies the principal locations of changes to these test methods that have been incorporated this standard since the last issue.

- ~~(1) Added new sentence at edition (1996) that may impact the end use of Section 1.2, Method 3, this test method.~~
- (1) Changed “moisture” to clarify the applicable materials as required “water content” in Test Method D 698 when using 4-in. (101.60-mm) mold.
- ~~(2) Added Practice D 3740 as a Sections 5.18, 7.2.4, 8.1.2, 8.1.4, 8.2.2 and Note 7 to conform with D 18 terminology.~~
- (2) Changed referenced document sections for Method A and Method B in Section 1.2.
- (3) Added new Section 1.3 to conform reference D 6026. Renumbered subsequent sections.
- (4) Revised Section 1.4 to clarify units used in the recommended D-18 practice.
- ~~(3) Added new test methods.~~
- (5) Updated titles and added D 653, D 2216, D 4753, D 6026 and E 145 to “Referenced Documents” section.
- (6) Updated Note 1 in Section 3 to reference statement on Practice D 3740.
- (7) Added new Section 3 on “Terminology”. Renumbered subsequent sections.
- (8) Change rd “weight” to “mass” throughout standard.
- (9) Revised Sections 5.4, 5.5, 5.9 and 5.18 to conform with D 18 policies and guidelines.
- (9) Corrected errors with respect to significant digits.
- ~~(4) Added new Section 10 6 on Keywords.~~
- ~~(5) Added Summary of Changes “Calibration”. Renumbered subsequent sections.~~
- (11) Revised Section 7.2.2 to reflect the changes made in this revision.
- ~~(6) Changed “moisture content” provide clarity and to “w include significant digits.~~
- (12) Revised Section 7.2.3 for clarity and added more specific instructions.
- (13) Revised last sentence in Sections 1.1, 4.5, 5.1.4, 5.2.2, 5.2.5, 5.2.8, 5.3.7, 6.2.2, 7.1, 7.1.2, 8.1.1, 8.1.2, 7.3.1 and 8.1.4 7.3.2 for clarity.
- (14) Revised Section 10 “Report” to conform to current D-18 Terminology. add new requirements.
- (15) Revised Note 7.
- (16) Revised “Summary of Changes” section.

*ASTM International takes no position respecting the validity of any patent rights asserted in connection with any item mentioned in this standard. Users of this standard are expressly advised that determination of the validity of any such patent rights, and the risk of infringement of such rights, are entirely their own responsibility.*

*This standard is subject to revision at any time by the responsible technical committee and must be reviewed every five years and if not revised, either reapproved or withdrawn. Your comments are invited either for revision of this standard or for additional standards and should be addressed to ASTM International Headquarters. Your comments will receive careful consideration at a meeting of the responsible technical committee, which you may attend. If you feel that your comments have not received a fair hearing you should make your views known to the ASTM Committee on Standards, at the address shown below.*

*This standard is copyrighted by ASTM International, 100 Barr Harbor Drive, PO Box C700, West Conshohocken, PA 19428-2959, United States. Individual reprints (single or multiple copies) of this standard may be obtained by contacting ASTM at the above address or at 610-832-9585 (phone), 610-832-9555 (fax), or [service@astm.org](mailto:service@astm.org) (e-mail); or through the ASTM website ([www.astm.org](http://www.astm.org)).*