



Standard Test Method for Measurement of Hydraulic Conductivity of Porous Material Using a Rigid-Wall, Compaction-Mold Permeameter¹

This standard is issued under the fixed designation D 5856; the number immediately following the designation indicates the year of original adoption or, in the case of revision, the year of last revision. A number in parentheses indicates the year of last reapproval. A superscript epsilon (ϵ) indicates an editorial change since the last revision or reapproval.

1. Scope

1.1 This test method covers laboratory measurement of the hydraulic conductivity (also referred to as *coefficient of permeability*) of laboratory-compacted materials with a rigid-wall, compaction-mold permeameter.

1.2 This test method may be used with laboratory-compacted specimens that have a hydraulic conductivity less than or equal to 1×10^{-5} m/s. The hydraulic conductivity of compacted materials that have hydraulic conductivities greater than 1×10^{-5} m/s may be determined by Test Method D 2434.

1.3 The values stated in SI units are to be regarded as the standard, unless other units are specifically given. By tradition in U.S. practice, hydraulic conductivity is reported in centimetres per second, although the common SI units for hydraulic conductivity are metres per second.

1.4 *This standard does not purport to address all of the safety concerns, if any, associated with its use. It is the responsibility of the user of this standard to establish appropriate safety and health practices and determine the applicability of regulatory limitations prior to use.*

2. Referenced Documents

2.1 ASTM Standards:

- D 653 Terminology Relating to Soil, Rock, and Contained Fluids²
- D 698 Test Method for Laboratory Compaction Characteristics of Soil Using Standard Effort (12 400 ft-lbf/ft³ (600 KN-m/m³))²
- D 854 Test Method for Specific Gravity of Soils²
- D 1557 Test Method for Laboratory Compaction Characteristics of Soil Using Modified Effort (56 000 ft-lbf/ft³ (2700 KN-m/m³))²
- D 2216 Method for Laboratory Determination of Water (Moisture) Content in Soil and Rock²
- D 2434 Test Method for Permeability of Granular Soils (Constant Head)²
- D 4753 Specification for Evaluating, Selecting, and Specifying Balances and Scales for Use in Testing Soil, Rock, and Related Construction Materials²

¹ This test method is under the jurisdiction of ASTM Committee D-18 on Soil and Rock and is the direct responsibility of Subcommittee D18.04 on Hydrologic Properties of Soil and Rock.

Current edition approved Nov. 10, 1995. Published January 1996.

² Annual Book of ASTM Standards, Vol 04.08.

D 5084 Test Method for Measurement of Hydraulic Conductivity of Saturated Porous Materials Using a Flexible Wall Permeameter²

E 145 Specification for Gravity-Convection and Forced-Ventilation Ovens³

3. Terminology

3.1 Definitions of Terms Specific to This Standard:

3.1.1 *flux*—quantity of flow per unit area per unit time.

3.1.2 *hydraulic conductivity, k*—the rate of discharge of water under laminar flow conditions through a unit cross-sectional area of a porous medium under a unit hydraulic gradient and standard temperature conditions (20°C).

3.1.2.1 *Discussion*—The term *coefficient of permeability* is often used instead of *hydraulic conductivity*, but *hydraulic conductivity* is used exclusively in this test method. A more complete discussion of the terminology associated with Darcy's law is given in the literature⁴.

3.1.3 *pore volume of flow*—the cumulative quantity of outflow from a test specimen divided by the volume of pore space in the specimen.

3.1.4 For definitions of other terms used in this test method see Terminology D 653.

4. Significance and Use

4.1 This test method applies to one-dimensional, laminar flow of water within laboratory-compacted, porous materials such as soil.

4.2 The hydraulic conductivity of porous materials generally decreases with an increasing amount of air in the pores of the material. This test method applies to porous materials containing little or no air. The test method is designed to minimize the amount of air in the test specimen. However, this test method does not ensure complete saturation of the test specimen with water. In cases where it is essential to saturate the test specimen fully with water, the compacted specimen may be tested using Test Method D 5084.

4.3 This test method applies to permeation of porous materials with water. Permeation with other liquids, such as

³ Annual Book of ASTM Standards, Vol 04.02.

⁴ Olson, R. E., and Daniel, D. E., "Measurement of the Hydraulic Conductivity of Fine-Grained Soils," *Symposium on Permeability and Groundwater Contaminant Transport, ASTM STP 746*, ASTM, 1981, pp. 18–64.

chemical wastes, can be accomplished using procedures similar to those described in this test method. However, this test method is only intended to be used when water is the permeant liquid.

4.4 It is assumed that Darcy's law is valid and that the hydraulic conductivity is essentially unaffected by hydraulic gradient. The validity of Darcy's law may be evaluated by measuring the hydraulic conductivity of the specimen at three hydraulic gradients; if all measured values are similar (within 25 %), then Darcy's law may be taken as valid. However, when the hydraulic gradient acting on a test specimen is changed, the state of stress will also change, and, if the specimen or pore fluid is compressible, the volume of the test specimen or pore fluid will change. Thus, some change in hydraulic conductivity may occur when the hydraulic gradient is altered, even in cases where Darcy's law is valid.

4.5 One potential problem with this method of testing is the possibility that water will flow along the interface between the test specimen and the compaction/permeameter ring. The problem tends to be of minimal significance for materials that swell when exposed to water (for example, compacted, clayey soils) but can be a very serious problem for materials that might tend to shrink and pull away from the walls of the permeameter. Test Method D 5084 is recommended for any material that tends to shrink when exposed to the permeant liquid.

4.6 The correlation between results obtained with this test method and the hydraulic conductivities of in-place, compacted materials has not been fully investigated. Experience has sometimes shown that flow patterns in small, laboratory-prepared test specimens do not necessarily follow the same patterns on large field scales and that hydraulic conductivities measured on small test specimens are not necessarily the same as larger-scale values. Therefore, the results should be applied to field situations with caution and by qualified personnel.

5. Apparatus

5.1 *Hydraulic System*—Constant head (Test Method A), falling head (Test Methods B, C, and D), or constant rate of flow (Test Method E) systems may be used provided they meet the criteria outlined as follows:

5.1.1 *Constant Head*—The system must be capable of maintaining a constant hydraulic pressure or head to within $\pm 5\%$ and shall include means to measure hydraulic pressures or heads to within the prescribed tolerance. In addition, the head loss across the test specimen must be held constant to within $\pm 5\%$ and shall be measured with the same accuracy or better. Pressures shall be measured by a pressure gage, electronic pressure transducer, or any other device of suitable accuracy. Head of liquid in a standpipe may be measured with a graduated pipette, ruler, scale, or other device of suitable accuracy.

5.1.2 *Falling Head*—The system shall allow for measurement of the applied head loss, thus hydraulic gradient, to within $\pm 5\%$ or better at any time. In addition, the ratio of initial head loss divided by final head loss over an interval of time shall be measured such that this computed ratio is accurate to within $\pm 5\%$. The head loss shall be measured with a pressure gage, electronic pressure transducer, engineer's scale,

graduated pipette, or any other device of suitable accuracy. Falling head tests may be performed with either a constant tailwater elevation (Test Method B), rising tailwater elevation (Test Method C), or increasing tailwater elevation (Test Method D).

5.1.3 *Constant Rate of Flow*—The system must be capable of maintaining a constant rate of flow through the specimen to within $\pm 5\%$ or better. Flow measurement or control shall be by calibrated syringe, graduated pipette, or other device of suitable accuracy. The head loss across the specimen shall be measured to an accuracy of $\pm 5\%$ or better using an electronic pressure transducer or other device of suitable accuracy. A means to ensure that the head being measured is not affected by sidewall leakage should be included. More information on testing with a constant rate of flow is given in the literature⁵.

5.2 *Flow Measurement System*—Both inflow and outflow volumes shall be measured or controlled. Flow volumes shall be measured by a graduated accumulator, graduated pipette, graduated cylinder, vertical standpipe in conjunction with an electronic pressure transducer, marriott bottle, or other volume-measuring device of suitable accuracy. For long-term tests, evaporative losses may be significant and should be accounted for using a suitable correction procedure.

5.2.1 *Flow Accuracy*—Required accuracy for the quantity of flow measured over an interval of time is $\pm 5\%$ or better.

5.2.2 *Head Losses*—Head losses in the tubes, valves, porous end pieces, and filter paper may lead to error. To guard against such errors, the permeameter shall be assembled with no specimen inside (but with any porous end pieces or sheets of filter paper that will be used) and then the hydraulic system filled. If a constant or falling head test is to be used, the hydraulic pressures or heads that will be used in testing a specimen shall be applied, and the rate of flow measured with an accuracy of $\pm 5\%$ or better. This rate of flow shall be at least ten times greater than the rate of flow that is measured when a specimen has been compacted inside the permeameter and the same hydraulic pressures or heads are applied. If a constant rate of flow test is to be used, the rate of flow to be used in testing a specimen shall be supplied to the permeameter and the head loss measured. The head loss without a specimen shall be less than 0.1 times the head loss when a specimen is present.

5.3 *Permeameter Cell*—The permeameter cell shall consist of a rigid-wall compaction mold into which the material to be tested is compacted and in which the compacted material is permeated; and two end plates to control flow into and out of the test specimen. A swell ring may be provided as discussed in 5.3.2. The permeameter shall be designed and operated so that permeant water flows downward through the test specimen, although upward flow may be used if the top of the specimen is protected from upward movement by a rigid porous element.

5.3.1 *Compaction Mold/Permeameter Ring*—The compaction mold/permeameter ring shall be constructed of a rigid material that will not be damaged during compaction of the test specimen and that will not undergo adverse chemical reactions

⁵ Olsen, H. W., Gill, J. D., Willden, A. T., and Nelson, N. R., "Innovations in Hydraulic Conductivity Measurements," *Transportation Research Record No. 1309*, Transportation Research Board, National Research Council, Washington, DC, 1991.

with the test material or permeant water. Materials such as steel, aluminum, brass, plastic, and glass have been used. The mold shall be sufficiently rigid so that its expansion when the permeameter is pressurized is negligibly small. The mold can be any cylindrical shape so long as: the cross-sectional area along the direction of flow does not vary by more than $\pm 2\%$; height and diameter are each ≥ 25 mm; height does not vary by more than $\pm 1\%$, and the largest particle and clod size in the compacted specimen is $\leq \frac{1}{6}$ the lesser of the height or diameter.

5.3.2 Swell Ring—The top of the permeameter may be designed to function in one of three ways: (1) to allow no restraint against swelling (see Fig. 1), in which case a swell ring separates the compaction mold/permeameter ring from the top plate; (2) to allow no swelling of the test specimen (see Fig. 2), in which case no swell ring is provided; or (3) to control the vertical stress that is applied to the test specimen (see Fig. 3), in which case a swell ring may or may not be needed, depending upon how the top plate is designed and how the vertical stress is applied. If a swell ring is used, it shall be constructed of a rigid material that will not react adversely with the test material or permeant water, shall have the same diameter or width as the compaction mold/permeameter ring, and shall be sufficiently high to allow free swelling of the test specimen or to accommodate stress-control apparatus. Sand may be placed in the swell ring to minimize erosion of the specimen from influent flow provided that the sand is included in the measurement of head losses in the permeameter (see 5.2.2).

5.3.3 Stress-Control Apparatus—If the upper surface of the compacted test specimen is subjected to a controlled vertical stress, the stress shall be applied through a rigid plate using any means that maintains the stress within $\pm 5\%$ of the desired value.

5.3.4 Bottom Plate—The bottom plate shall be constructed of rigid material that does not react adversely with the test material or permeant liquid. The plate shall serve the purpose

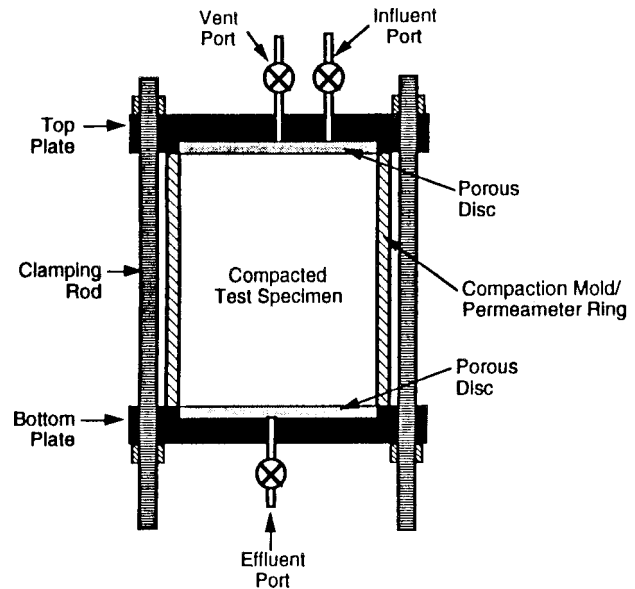

FIG. 2 Compaction-Mold Permeameter in Which Test Specimen Cannot Swell

of preventing the test specimen from swelling downward, supporting the test specimen, collecting effluent liquid from the base of the test specimen, and ensuring one-dimensional flow near the effluent end of the test specimen. The base plate shall be sealed to the compaction mold/permeameter ring, for example, with an O-ring, to prevent leakage. Checks for leaks, conducted without soil in the cell, are helpful to ensure adequacy of the seals. Careful examination of the seal is particularly important when the apparatus is disassembled and re-assembled during the test. The bottom plate shall contain a porous material (such as porous plastic, porous metal, porous corundum, or well-compacted sand) that is far more permeable than the test specimen (5.2.2 ensures that this is the case) and that has the same overall diameter or width as the test specimen. Two base plate designs are acceptable:

5.3.4.1 Single-Ring—This design (Fig. 1, Fig. 2, and Fig. 3) consists of a single porous material with the same diameter or

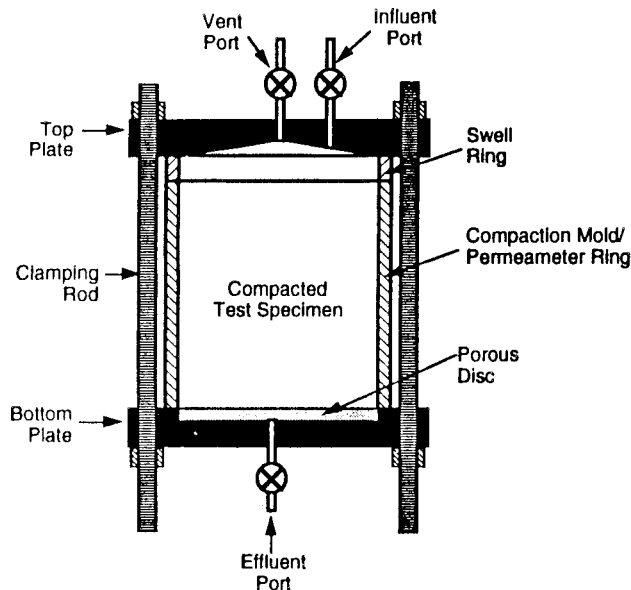

FIG. 1 Compaction-Mold Permeameter with No Restraint Against Swelling at Top of Test Specimen

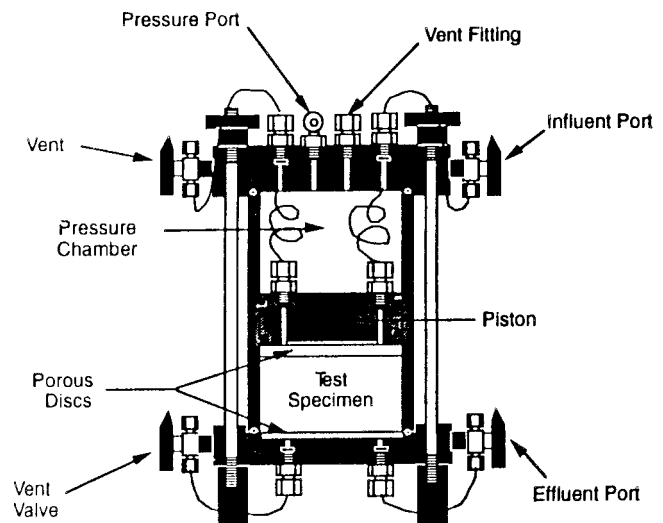

FIG. 3 Compaction-Mold Permeameter With a Controlled Vertical Stress Applied to the Top of the Test Specimen

width as the test specimen.

5.3.4.2 *Double Ring*—With this design (see Fig. 4), outflow from the central part of the test specimen is separated from flow near the sidewalls in the base plate. The system shall be designed so that the collector ring (see Fig. 4) protrudes approximately 3 mm into the test specimen and completely separates flow entering the base plate through the inner zone from flow entering the outer zone. A thin ring with a sharp edge should be used to prevent disturbance of the soil during installation.

NOTE 1—The double ring is preferred over the single ring because the double ring provides a means for identifying erroneous measurements caused by side-wall leakage. Unless the requestor specifically requests a single-ring base plate, the double-ring base plate shall be used.

5.3.5 *Top Plate*—The top plate shall be constructed from rigid materials that do not react adversely with the test material or permeant water. The top plate shall be sealed to the compaction mold/permeameter ring or swell ring (if present) in a way that prevents leakage. Tests for leaks, conducted without soil in the cell, are helpful to ensure the adequacy of the seals. The plate shall be designed to ensure that flow through the test specimen is one-dimensional.

5.4 *Filter Paper*—If necessary to prevent intrusion of material into the pores of the porous end pieces, one or more sheets of filter paper shall be placed between the top and bottom porous end pieces and the specimen. The paper shall have a negligibly small hydraulic impedance. The requirements outlined in 5.2.2 ensure that the impedance is small.

5.5 *Equipment for Compacting a Specimen*—Equipment (including compactor and mold) suitable for the method of compaction specified by the requestor shall be used. Examples of compaction equipment/procedures are Test Methods D 698 and D 1557.

5.6 *Devices for Measuring the Dimensions of the Specimen*—Devices used to measure the dimensions of the specimen shall be capable of measuring to the nearest 0.3 mm

(0.01 in.) or better and shall be constructed such that their use will not disturb the specimen.

5.7 *Balances*—The balance shall be suitable for determining the mass of the specimen and shall be selected as discussed in Specification D 4753. The mass of specimens less than 100 g shall be determined to the nearest 0.01 g. The mass of specimens 100 g or larger shall be determined to the nearest 0.1 g. The mass of specimens > 1000 g shall be determined to the nearest 1.0 g.

5.8 *Temperature Maintaining Device*—The temperature of the permeameter, test specimen, and reservoir of permeant liquid shall not vary more than $\pm 3^{\circ}\text{C}$ ($\pm 5.7^{\circ}\text{F}$). Normally, this is accomplished by performing the test in a room with a relatively constant temperature. If such a room is not available, the apparatus shall be placed in a water bath, insulated chamber, or other device that maintains a temperature within the tolerance specified above. The temperature shall be periodically measured and recorded.

5.9 *Water Content Containers*—The containers shall be in accordance with Test Method D 2216.

5.10 *Drying Oven*—The oven shall be in accordance with Specification E 145.

6. Reagents

6.1 Permeant Water:

6.1.1 The permeant water is the liquid used to permeate the test specimen. Any liquid introduced into the test specimen, porous elements, filter paper, or other portions of the permeameter shall be permeant water.

6.1.2 The type of permeant water shall be specified by the requestor. If no specification is made, de-aired tap water shall be used for the permeant liquid. The type of water used shall be indicated in the report. Regardless of the type of permeant water requested, the water shall be de-aired water (see 6.1.3), unless the requestor specifically requests that the water not be de-aired.

NOTE 2—Chemical interactions between a permeant liquid and the porous material may lead to variations in hydraulic conductivity. Distilled water can significantly lower the hydraulic conductivity of clayey soils.⁴ For this reason, distilled water is not usually recommended as a permeant liquid. A permeant liquid used by some is 0.005 N CaSO_4 , that can be obtained, for example, by dissolving 6.8 g of non-hydrated, reagent-grade CaSO_4 in 10 L of de-aired, distilled (or de-ionized) water. This CaSO_4 solution is thought to neither increase nor decrease significantly the hydraulic conductivity of clayey soils. In areas with extremely brackish tap water, the CaSO_4 solution is recommended.

6.1.3 To aid in removing as much air from the test specimen as possible, de-aired water shall be used. The water is usually de-aired by boiling, by spraying a fine mist of water into an evacuated vessel attached to a vacuum source, or by forceful agitation of water in a container attached to a vacuum source. If boiling is used, care shall be taken not to evaporate an excessive amount of water, which can lead to a larger salt concentration in the permeant water than desired. To prevent dissolution of air back into the water, de-aired water shall not be exposed to air for prolonged periods.

7. Test Specimen

7.1 *Preparation of Compaction/Permeameter Ring*—Prior to compaction, determine the inside dimensions of the

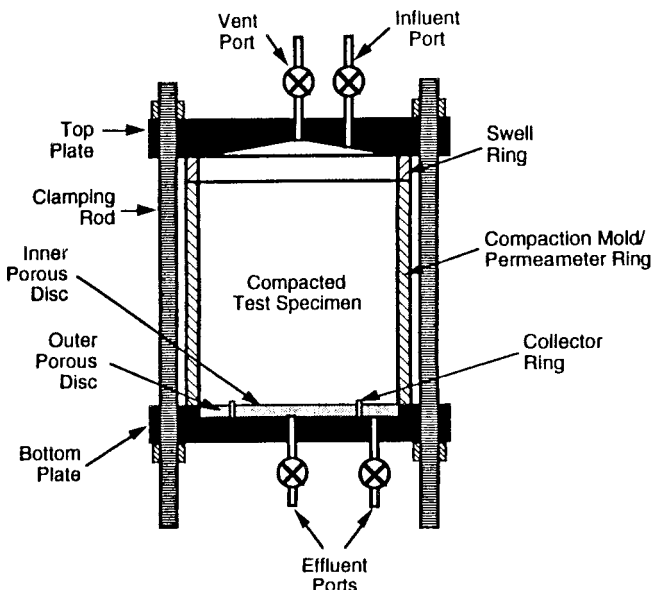

FIG. 4 Compaction-Mold Permeameter With Double Ring in Base Plate

compaction/permeameter ring to the tolerances given in 5.3.1, and determine the mass of the compaction/permeameter ring to the tolerances given in 5.7. If desired, the inside of the permeameter may be coated with a thin layer of sodium bentonite paste to minimize the possibility of side-wall leakage.

7.2 Compaction—Prepare the material to be tested and compacted inside the compaction/permeameter ring in a manner specified by the requestor. If the specimen is placed and compacted in layers, lightly scarify the surface of each previously-compacted layer (roughen) with a fork, ice pick, or other suitable object, unless the requestor specifically states that scarification is not to be performed. Test Methods D 698 and D 1557 describe two methods of compaction, but any other method specified by the requestor may be used as long as the method is described in the report. Large clods of material should not be broken down prior to compaction unless it is known that they will be broken in field construction, as well, or the requestor specifically requests that the clod size be reduced. Neither hard clods nor individual particles of the material shall exceed 1/6 of either the height or diameter of the specimen. After compaction, determine the mass of the compaction/permeameter ring containing the compacted specimen and immediately mount the compaction/permeameter ring containing the test specimen in the permeameter. Determine the water content of the trimmings or excess material in accordance with Test Method D 2216. Determine the mass (M) of the test specimen by subtracting the mass of the compaction/permeameter ring from the mass of the compaction/permeameter ring plus test specimen.

7.3 Calculate the total volume of the test specimen (V) from the length (L) and diameter (D) of the test specimen as follows:

$$V = \frac{\pi D^2 L}{4} \quad (1)$$

7.4 Calculate the initial dry density (ρ_{di}) of the compacted specimen and porosity (n) of the test specimen from the mass (M) and volume of the specimen (V) and from the approximate water content (w , in decimal form) of the specimen as follows:

$$\rho_{di} = \frac{M}{(1 + w)V} \quad (2)$$

and:

$$n = 1 - \frac{\rho_{di}}{G_s \rho_w} \quad (3)$$

where:

G_s = the specific gravity of solids, that shall either be measured according to Test Method D 854 or estimated.

NOTE 3—Accurate measurement of the specific gravity of solids of many materials is difficult. The specific gravity of solids shall be determined with an estimated accuracy of ± 0.05 . For many materials, it is possible to estimate G_s within this accuracy.

7.5 Calculate the volume of the pores in the test specimen (V_p) as follows:

$$V_p = nV \quad (4)$$

8. Procedure

8.1 Specimen Set-Up:

8.1.1 If filter paper is used to prevent clogging of porous end pieces, cut filter paper sheets to approximately the same shape as the cross section of the test specimen.

8.1.2 Soak any porous end pieces (discs) and filter paper sheets to be used in a container of permeant water and place the filter paper sheets on the porous end pieces.

8.1.3 Assemble the permeameter cell and fill it with de-aired permeant water. Flush permeant water through the influent line to remove any entrapped gas.

NOTE 4—Care should be exercised when assembling permeameters with a double ring in the base plate to ensure seating of the ring in the specimen. A restraining ring can be placed on top of the specimen during assembly to prevent slippage of the specimen as it is pressed into the ring. Alternatively, the specimen can be compacted directly on the base of the permeameter. If this latter procedure is used, then the base plate and ring should be sturdy enough to prevent breakage during compaction.

8.1.4 If a controlled stress is to be applied to the upper surface of a test specimen, apply it at this stage.

8.2 Permeation:

8.2.1 Hydraulic Gradient—When possible, the hydraulic gradient used for hydraulic conductivity measurements should be similar to that expected to occur in the field. In general, hydraulic gradients from < 1 to 5 cover most field conditions. However, the use of small hydraulic gradients can lead to very long testing times for materials having low hydraulic conductivity (less than about 1×10^{-8} m/s). Somewhat larger hydraulic gradients are usually used in the laboratory to accelerate testing, but excessive gradients must be avoided because high seepage pressures may consolidate the material, material may be washed from the specimen, channeling along the sidewall may occur, or fine particles may be washed downstream and plug the effluent end of the test specimen. These effects could increase or decrease hydraulic conductivity. For high hydraulic gradients (> 20), a base plate with a double ring (see Fig. 4) is recommended to avoid anomalous measurements caused by channeling along the sidewall. If no hydraulic gradient is specified by the requestor, the following guidelines may be followed:

Hydraulic Conductivity (m/s)	Recommended Maximum Hydraulic Gradient
1×10^{-5} to 1×10^{-6}	2
1×10^{-6} to 1×10^{-7}	5
1×10^{-7} to 1×10^{-8}	10
1×10^{-8} to 1×10^{-9}	20
$< 1 \times 10^{-9}$	30

The constant flow rate method may be advantageous if low gradients and short testing times are desired for testing saturated materials with very low hydraulic conductivity.⁵

8.2.2 Initialization—Initiate permeation of the specimen by increasing the influent pressure. The pressure at the effluent end of the test specimen is normally atmospheric pressure (see Note 5). If restraint against upward movement of the specimen is provided, initially flowing the permeant upward may assist in saturation.

NOTE 5—Backpressure is normally not applied in this type of test. If backpressure is used, the flexible wall permeameter (see Test Method D 5084) is recommended. If backpressure is specifically requested with

this test method, the requestor shall specify the magnitude of the backpressure. If backpressure is used, use a double-ring effluent collector (see Fig. 5) or employ some other suitable methodology to ensure that the backpressure has not expanded the permeameter ring and caused spurious sidewall leakage.

8.2.3 Constant Head Test (Test Method A)—Measure and record the head loss across the test specimen and keep this head loss constant $\pm 5\%$. Measure and record periodically the quantity of inflow as well as the quantity of outflow. If a double-ring effluent collector is used, record the quantity of outflow from both collector rings. Continue permeation until at least four values of hydraulic conductivity are obtained over an interval of time in which: the ratio of outflow to inflow rate is between 0.75 and 1.25, the hydraulic conductivity is steady, and if a double-ring collector is used, the ratio of the flux from the outer ring to that from the inner ring is between 0.75 and 1.25. Consider the hydraulic conductivity steady if four or more consecutive hydraulic conductivity determinations fall within $\pm 25\%$ of the mean value for $k \geq 1 \times 10^{-10}$ m/s or within $\pm 50\%$ for $k < 1 \times 10^{-10}$ m/s, and a plot of the hydraulic conductivity versus time shows no significant upward or downward trend. See Note 6.

NOTE 6—If the test specimen has been prepared using a dry, highly expandable material such as sodium bentonite or has very low hydraulic conductivity ($< 1 \times 10^{-10}$ m/s), hydration may not be complete even when the requirements in 8.2.3 are met. If incomplete hydration is of concern, a suitable method of soaking the sample can be conducted prior to permeation.

8.2.4 Falling Head Tests (Test Methods B, C, and D)—Measure and record the head loss across the test specimen. At no time shall the applied head loss across the specimen be less than 75% of the initial (maximum) head loss during each individual hydraulic conductivity determination. Continue permeation until at least four values of hydraulic conductivity are obtained over an interval of time in which: the ratio of outflow to inflow rate is between 0.75 and 1.25, the hydraulic conductivity is steady (see 8.2.3), and if a double-ring collector is used, the ratio of the flux from the outer ring to that from the inner ring is between 0.75 and 1.25. See Note 6, Note 7, and Note 8.

NOTE 7—When the water pressure in a test specimen changes, the volume of the pore fluid (especially gas bubbles) can change and the test specimen itself may expand or contract. The requirement that the head loss not decrease very much during a falling head test is intended to minimize these potential sources of volume change.

NOTE 8—When the initial and final head losses across the test specimen do not differ by much, great accuracy is needed to comply with the requirement of 5.1.2 that the ratio of initial to final head loss be determined with an accuracy of $\pm 5\%$ or better. When the initial and final head losses over an interval of time do not differ very much, it may be possible to comply with the requirements of 8.2.3 and to treat the test as a constant head test.

8.2.4.1 Test with Constant Tailwater Level (Test Method B)—If the water pressure at the downstream (tailwater) end of the test specimen is kept constant, periodically measure and record either the quantity of inflow or the level of water in the influent standpipe; measure and record the quantity of outflow from the test specimen.

8.2.4.2 Test with Constant Headwater and Rising Tailwater Level (Test Method C)—If the water pressure at the upstream

(headwater) end of the test specimen is kept constant, periodically measure and record either the quantity of outflow or the level of water in the effluent standpipe; measure and record the quantity of inflow into the test specimen. A marriotte bottle is a convenient device to measure the quantity of inflow while maintaining a constant head.

8.2.4.3 Test with Decreasing Headwater Level and Increasing Tailwater Level (Test Method D)—If the water pressure at the downstream end of the test specimen rises during an interval of time, periodically measure and record either the quantity of inflow and outflow or the changes in water levels in the influent and effluent standpipes.

8.2.5 Constant Rate of Flow Tests (Test Method E)—Initiate permeation of the specimen by imposing a constant flow rate. Choose the flow rate so the hydraulic gradient does not exceed the value specified, or if none is specified, the value recommended in 8.2.1. Periodically measure the head loss across the test specimen. Continue permeation until at least four values of hydraulic conductivity are obtained over an interval of time in which hydraulic conductivity is steady (see 8.2.3) and, if a double-ring collector is used, the ratio of the flux from the outer ring to that from the inner ring is between 0.75 and 1.25 (see Note 6). The user shall also ensure that the system is devoid of leaks and that rate of inflow and outflow are similar. One method to verify these conditions is to periodically compare the rate of inflow and outflow and determine if the ratio of inflow to outflow rates is between 0.75 and 1.25. Other suitable methods also can be used.

NOTE 9—Volume measurements should be made after sufficient time has elapsed to permit flow in the measurement reservoirs that is at least ten times the finest graduation on the reservoir. Measurements may be made at shorter time intervals only if it can be ensured that accurate measurements of rate of flow or change in head can be made, or both.

8.3 Final Dimensions of the Specimen—After completion of permeation, reduce the applied pressures, carefully disassemble the permeameter cell, and examine the specimen. If the specimen is free to swell, measure the height of the specimen. If the length of the specimen is more than 1.15 times the original length, trim the specimen and repeat the hydraulic conductivity measurement (see Note 10). Take care when trimming the specimen not to smear material across the surface of the test specimen. After trimming, scarify the surface of the specimen. Once the test is complete, measure and record the final height, diameter, and total mass of the specimen. Then determine the final water content of the specimen by the procedure of Test Method D 2216.

NOTE 10—If the specimen swells into a swell ring, the boundary conditions at the influent end are uncertain. This problem is considered negligible if the amount of swell is less than or equal to 15% of the original length of the specimen. If the swell is more than 15%, the material that swelled into the swell ring must be trimmed away. If it is known prior to permeation that a large amount of swell will occur, the specimen may be trimmed at some intermediate point in the test, that is, it is not necessary to wait until all the requirements of Section 8 are satisfied prior to dismantling the cell and trimming away the material that swelled into the swell ring. However, all requirements must be met before a test is complete. Even if the height of the specimen is ≤ 1.15 times the original height, measure the entire length of specimen and then trim the specimen prior to determining the final length, mass, and water content (the final length, mass, and water content are to be determined on that

portion of the test specimen contained within the compaction mold/permeameter ring). Use the length measured prior to trimming for the calculation of hydraulic conductivity.

NOTE 11—For some gap-graded materials, migration of particles may affect the measured hydraulic conductivity. Reversing the direction of flow may be useful in assessing the effect of particle migration.

9. Calculation

9.1 *Constant Head and Constant Rate of Flow Tests (Test Methods A and E)*—Calculate the hydraulic conductivity, k , as follows:

$$k = \frac{QL}{At h} \quad (5)$$

where:

- k = hydraulic conductivity, m/s,
- Q = quantity of flow, taken as the average of inflow and outflow, m^3 ,
- L = length of specimen along path of flow, m,
- A = cross-sectional area of specimen, m^2 ,
- t = interval of time, s, over which the flow Q occurs, and
- h = difference in hydraulic head across the specimen, m of water.

NOTE 12—If a double-ring effluent collector is used, the outflow quantity shall be taken as the total quantity from both rings.

9.2 Falling Head Tests:

9.2.1 *Constant Tailwater Pressure (Test Method B) and Constant Headwater and Rising Tailwater (Test Method C)*—Calculate the hydraulic conductivity, k , as follows:

$$k = \frac{aL}{At} \ln\left(\frac{h_1}{h_2}\right) \quad (6)$$

where:

- a = cross-sectional area of the reservoir containing the influent liquid, m^2 ,
- L = length of the specimen, m,
- A = cross-sectional area of the specimen, m^2 ,
- t = elapsed time between determination of h_1 and h_2 , s,
- h_1 = head loss across the specimen, at time t_1 , m, and
- h_2 = head loss across the specimen at time t_2 , m.

NOTE 13—Test Method C only shall be used for tests conducted in a single ring permeameter (see Fig. 1 and Fig. 2) unless the set-up for a double ring test (see Fig. 4) ensures the tailwater elevations in the effluent reservoirs remain equal throughout the test. Provided the elevations remain equal, then $a = a_1 + a_2$

where:

- a_1 = cross-sectional area of the reservoir containing the effluent liquid from the inner ring, m^2 , and
- a_2 = cross-sectional area of the reservoir containing the effluent liquid from the outer ring, m^2 .

9.2.2 *Decreasing Headwater and Increasing Tailwater Pressure (Test Method D)*—Calculate the hydraulic conductivity, k , as follows:

$$k = \frac{a_{in} a_{out} L}{A t (a_{in} + a_{out})} \ln(h_1/h_2) \quad (7)$$

where:

- a_{in} = cross-sectional area of the reservoir containing the influent liquid, m^2 ,

- a_{out} = cross-sectional area of the reservoir containing the effluent liquid, m^2 ,
- L = length of the specimen, m,
- A = cross-sectional area of the specimen, m^2 ,
- t = elapsed time between determination of h_1 and h_2 , s,
- h_1 = head loss across the specimen at time t_1 , m, and
- h_2 = head loss across the specimen at time t_2 , m.

NOTE 14—For the case in Test Method D where $a_{out} = a_{in} = a$, the equation for calculating k for a falling head test with a rising tailwater level is:

$$k = \frac{aL}{2At} \ln\left(\frac{h_1}{h_2}\right) \quad (8)$$

Also, Test Method D only shall be used for tests conducted in a single ring permeameter (see Fig. 1 and Fig. 2) unless the set-up for a double ring test (see Fig. 4) ensures the tailwater elevations in the effluent reservoirs remain equal throughout the test. Provided the elevations remain equal, then $a_{out} = a_1 + a_2$

where:

- a_1 = cross-sectional area of the reservoir containing the effluent liquid from the inner ring, m^2 , and
- a_2 = cross-sectional area of the reservoir containing the effluent liquid from the outer ring, m^2 .

9.3 Correct the hydraulic conductivity to that for 20°C (68°F), k_{20} , by multiplying k by the ratio of the viscosity of water at test temperature, T , to the viscosity of water at 20°C (68°F), R_T , from Table 1, as follows:

$$k_{20} = R_T k \quad (9)$$

9.4 Let M_s denote the oven dried mass (in kilograms) of material comprising the test specimen, V , the final volume of the test specimen contained in the compaction mold/permeameter ring (in cubic metres), w (dimensionless) the final water content of the test specimen, and G_s the dimensionless specific gravity of solids (see Note 4). Determine the final dry density (ρ_{df} in kg/m^3) of the test specimen as follows:

$$\rho_{df} = \frac{M_s}{V} \quad (10)$$

TABLE 1 Correction Factor R_T for Viscosity of Water at Various Temperatures

Temperature (°C)	R_T	Temperature (°C)	R_T
1	1.723	26	0.869
2	1.664	27	0.850
3	1.611	28	0.832
4	1.560	29	0.814
5	1.511	30	0.797
6	1.465	31	0.780
7	1.421	32	0.764
8	1.379	33	0.749
9	1.339	34	0.733
10	1.301	35	0.719
11	1.265	36	0.705
12	1.230	37	0.692
13	1.197	38	0.678
14	1.165	39	0.665
15	1.135	40	0.653
16	1.106	41	0.641
17	1.077	42	0.629
18	1.051	43	0.618
19	1.025	44	0.607
20	1.000	45	0.598
21	0.976	46	0.585
22	0.953	47	0.575
23	0.931	48	0.565
24	0.910	49	0.556

and the final degree of saturation (S , expressed as a percentage):

$$S = \frac{w}{\frac{\rho_w}{\rho_{df}} \frac{1}{G_s}} \times 100 \quad (11)$$

where:

ρ_w = is the density of water (998.2 kg/m³ at 20°C).

9.5 Determine the number of pore volumes of inflow (N_{PV}) at the end of the test as follows:

$$N_{PV} = \frac{Q_{in}}{V_p} \quad (12)$$

where:

Q_{in} = is the cumulative quantity of inflow from the test specimen and V_p is the initial volume of the pore space within the test specimen (see 7.5).

10. Report

10.1 Report the following information:

- 10.1.1 Sample identifying information,
- 10.1.2 Any special selection and preparation process, such as removal of stones or other materials,
- 10.1.3 Descriptive information on method of compaction,
- 10.1.4 The initial dimensions of the specimen,
- 10.1.5 The initial water content and dry density of the specimen,
- 10.1.6 The type of permeant liquid used,
- 10.1.7 Type of permeameter used, including type (if any) of confinement against swelling, single- or double-ring base plate, and any non-standard test arrangement such as use of back-pressure,
- 10.1.8 The test method (A, B, C, D or E) used,
- 10.1.9 Hydraulic gradient (report the range, if variable),
- 10.1.10 The total number of pore volumes of permeant

liquid that came out of the test specimen and the duration of the test, measured from initiation of permeation to the end of the last set of readings used to determine hydraulic conductivity,

10.1.11 The final length, diameter, water content, dry density, and degree of saturation of the test specimen. Also report the specific gravity of solids used for computations and indicate whether this value was measured or assumed,

10.1.12 The amount of swelling that was measured and whether or not material was trimmed away from the swell ring (if applicable) prior to permeation,

10.1.13 The average hydraulic conductivity for the last four determinations of hydraulic conductivity, reported with two significant figures, for example, 7.1×10^{-10} m/s, and reported in units of m/s (plus additional units, if requested or customary),

10.1.14 A graph or table of hydraulic conductivity versus time or pore volumes of flow and a graph or table of the ratio of outflow to inflow flow rate versus time or pore volume of flow, and

10.1.15 If a double-ring effluent collector was used, report a graph or table of the ratio of flux from the outer ring to that from the inner ring versus time or pore volumes of flow.

11. Precision and Bias

11.1 *Precision*—Data are being evaluated to determine the precision of this test method. In addition, Subcommittee D18.04 on Hydrologic Properties of Soil and Rocks, is seeking pertinent data from users of the test method.

11.2 *Bias*—There is no accepted reference value for this test method; therefore, bias cannot be determined.

12. Keywords

12.1 coefficient of permeability; ground water; hydraulic barriers; hydraulic conductivity; liner; permeameter

The American Society for Testing and Materials takes no position respecting the validity of any patent rights asserted in connection with any item mentioned in this standard. Users of this standard are expressly advised that determination of the validity of any such patent rights, and the risk of infringement of such rights, are entirely their own responsibility.

This standard is subject to revision at any time by the responsible technical committee and must be reviewed every five years and if not revised, either reapproved or withdrawn. Your comments are invited either for revision of this standard or for additional standards and should be addressed to ASTM Headquarters. Your comments will receive careful consideration at a meeting of the responsible technical committee, which you may attend. If you feel that your comments have not received a fair hearing you should make your views known to the ASTM Committee on Standards, 100 Barr Harbor Drive, West Conshohocken, PA 19428.