



Standard Practice for Sampling of Soil Using the Hydraulically Operated Stationary Piston Sampler¹

This standard is issued under the fixed designation D 6519; the number immediately following the designation indicates the year of original adoption or, in the case of revision, the year of last revision. A number in parentheses indicates the year of last reapproval. A superscript epsilon (ε) indicates an editorial change since the last revision or reapproval.

1. Scope

1.1 This practice covers a procedure for sampling of cohesive, organic, or fine-grained soils, or combination thereof, using a thin-walled metal tube that is inserted into the soil formation by means of a hydraulically operated piston. It is used to collect relatively undisturbed soil samples suitable for laboratory tests to determine structural and chemical properties for geotechnical and environmental site characterizations.

1.1.1 Guidance on preservation and transport of samples in accordance with Practice D 4220 may apply. Samples for classification may be preserved using procedures similar to Class A. In most cases, a thin-walled tube sample can be considered as Class B, C, or D. Refer to Guide D 6286 for use of the hydraulically operated stationary piston soil sampler for environmental site characterization. This sampling method is often used in conjunction with rotary drilling methods such as fluid rotary; Guide D 5783; and hollow stem augers, Practice D 6151. Sampling data should be reported in the substance log in accordance with Guide D 5434.

1.2 The hydraulically operated stationary piston sampler is limited to soils and unconsolidated materials that can be penetrated with the available hydraulic pressure that can be applied without exceeding the structural strength of the thin-walled tube.

1.3 *This practice does not purport to address all the safety concerns, if any, associated with its use and may involve use of hazardous materials, equipment, and operations. It is the responsibility of the user to establish and adopt appropriate safety and health practices. Also, the user must comply with prevalent regulatory codes, such as OSHA (Occupational Health and Safety Administration) guidelines, while using this practice. For good safety practice, consult applicable OSHA regulations and other safety guides on drilling.*²

1.4 The values stated in SI units or inch-pound units are to be regarded separately as standard. The values stated in each system may not be exact equivalents; therefore, each system

shall be used independently of the other. Combining values from the two systems may result in nonconformance with the standard.

1.5 *This practice offers a set of instructions for performing one or more specific operations. This document cannot replace education or experience and should be used in conjunction with professional judgement. Not all aspects of this practice may be applicable in all circumstances. This ASTM standard is not intended to represent or replace the standard of care by which the adequacy of a given professional service must be judged, nor should this document be applied without consideration of a project's many unique aspects. The word "Standard" in the title means only that the document has been approved through the ASTM consensus process. This practice does not purport to comprehensively address all of the methods and the issues associated with sampling of soil. Users should seek qualified professionals for decisions as to the proper equipment and methods that would be most successful for their site investigation. Other methods may be available for drilling and sampling of soil, and qualified professionals should have flexibility to exercise judgment as to possible alternatives not covered in this practice. The practice is current at the time of issue, but new alternative methods may become available prior to revisions, therefore, users should consult with manufacturers or producers prior to specifying program requirements.*

2. Referenced Documents

2.1 ASTM Standards-Soil Classification:

D 653 Terminology Relating to Soil, Rock, and Contained Fluids³

D 2488 Practice for Description and Identification of Soils (Visual-Manual Method)³

D 5434 Guide for Field Logging of Subsurface Explorations of Soil and Rock³

2.2 ASTM Standards-Drilling Methods:

D 1452 Practice for Soil Investigation and Sampling by Auger Borings³

D 5782 Guide for Use of Direct Air-Rotary Drilling for Geoenvironmental Exploration and the Installation of Subsurface Water-Quality Monitoring Devices⁴

¹ This practice is under the jurisdiction of ASTM Committee D-18 on Soil and Rock and is the direct responsibility of Subcommittee D18.02 on Sampling and Related Field Testing for Soil Evaluation

Current edition approved Jan. 10, 2000. Published April 2000.

² *Drilling Safety Guide*, National Drilling Assn., 3008 Millwood Ave., Columbia, SC 29205.

³ *Annual Book of ASTM Standards*, Vol 04.08.

⁴ *Annual Book of ASTM Standards*, Vol 04.09.

- D 5783 Guide for Use of Direct Rotary Drilling with Water-Based Drilling Fluid for Geoenvironmental Exploration and the Installation of Subsurface Water-Quality Monitoring Devices⁴
- D 5784 Guide for Use of Hollow-Stem Augers for Geoenvironmental Exploration and the Installation of Subsurface Water-Quality Monitoring Devices⁴
- D 6151 Practice for Using Hollow-Stem Augers for Geotechnical Exploration and Soil Sampling⁴
- D 6286 Selection of Drilling Methods for Environmental Site Characterization
- 2.3 *ASTM Standards—Soil Sampling:*
 - D 420 Guide to Site Characterization for Engineering, Design, and Construction Purposes³
 - D 1587 Practice for Thin-Walled Tube Geotechnical Sampling of Soils³
 - D 3694 Practices for Preparation of Sample Containers and for Preservation of Organic Constituents⁵
 - D 4700 Guide for Soil Sampling from the Vadoze Zone³
 - D 5299 Guide for Decommissioning of Ground Water Wells, Vadose Zone, Monitoring Devices, Boreholes, and Other Devices for Environmental Activities³
 - D 4220 Practices for Preserving and Transporting Soil Samples³
 - D 6169 Guide for Selection of Soil and Rock Sampling Devices Used With Drill Rigs for Environmental Investigations⁴

3. Terminology

3.1 Terminology used within this guide is in accordance with Terminology D 653 with the addition of the following:

3.1.1 *incremental drilling and sampling*—insertion method where rotary drilling and sampling events are alternated for incremental sampling. Incremental drilling is often needed to penetrate harder or deeper formations.

3.1.2 *sample recovery*—the length of material recovered divided by the length of sampler advancement and stated as a percentage.

3.1.3 *sample interval*—Defined zone within a subsurface strata from which a sample is gathered.

3.1.4 *soil core*—cylindrically shaped soil specimen recovered from a sampler.

3.2 *Definitions of Terms Specific to This Standard:*

3.2.1 *friction clutch*—a device to lock the thin-walled tube head to the outer barrel of the stationary piston sampler to prevent uncontrolled thin-walled tube rotation.

3.2.2 *hydraulically activated stationary piston sampler*—a stationary piston sampler in which the thin-walled tube is forced over a fixed piston into the soil strata by hydraulic fluid pressure or pneumatic pressure. Also known as an “Osterberg” piston sampler, which was developed by Professor Jori Osterberg of Northwestern University.

4. Summary of Practice

4.1 Hydraulic stationary piston sampling of soils consists of advancing a sampling device into subsurface soils generally

through a predrilled bore hole to the desired sampling depth. See Fig. 1 for a schematic drawing of the sampling process. The sampler is sealed by the stationary piston to prevent any intrusion of formation material. At the desired depth, fluid or air is forced into the sampling barrel, above the inner sampler head, forcing the thin-walled tube sampler over the piston into the soil formation. The hydraulically operated stationary piston sampler has a prescribed length of travel. At the termination of the sampler travel length the fluid flow is terminated. The sample is allowed to stabilize in the thin-walled tube. The sample is then sheared by rotating the sampler. The sampler is retrieved from the borehole, and the thin-walled tube with the sample is removed from the sampler. The sample tube is then sealed properly or field-extruded as desired. The stationary piston sampler is cleaned and a clean thin-walled tube installed. The procedure is repeated for the next desired sampling interval. Sampling can be continuous for full-depth borehole logging or incremental for specific interval sampling.

5. Significance and Use

5.1 Hydraulically activated stationary piston samplers are used to gather soil samples for laboratory or field testing and analysis for geologic investigations, soil chemical composition studies, and water quality investigations. The sampler is sometimes used when attempts to recover unstable soils with thin-walled tubes, Practice D 1587, are unsuccessful. Examples of a few types of investigations in which hydraulic stationary piston samplers may be used include building site foundation studies containing soft sediments, highway and dam foundation investigations where softer soil formation need evaluation, wetland crossings utilizing floating structures, and hazardous waste site investigations. Hydraulically activated stationary piston samplers provide specimens necessary to determine the physical and chemical composition of soils and, in certain circumstances, contained pore fluids (see Guide D 6169).

5.2 Hydraulically activated stationary piston samplers can provide relatively undisturbed soil samples of soft or loose formation materials for testing to determine accurate information on the physical characteristics of that soil. Samples of soft formation materials can be tested to determine numerous soil characteristics such as; soil stratigraphy, particle size, moisture content, permeability, shear strength, compressibility, and so forth. The chemical composition of soft formation soils can also be determined from the sample if provisions are made to ensure that clean, decontaminated tools are used in the sample gathering procedure. Field-extruded samples can be field-screened or laboratory-analyzed to determine the chemical composition of soil and contained pore fluids. Using sealed or protected sampling tools, cased boreholes, and proper advancement techniques can help in the acquisition of good representative samples. A general knowledge of subsurface conditions at the site is beneficial.

5.3 The use of this practice may not be the correct method for investigations of softer formations in all cases. As with all sampling methods, subsurface conditions affect the performance of the sample gathering equipment and methods used. For example, research indicates that clean sands may undergo

⁵ Annual Book of ASTM Standards, Vol 11.02.

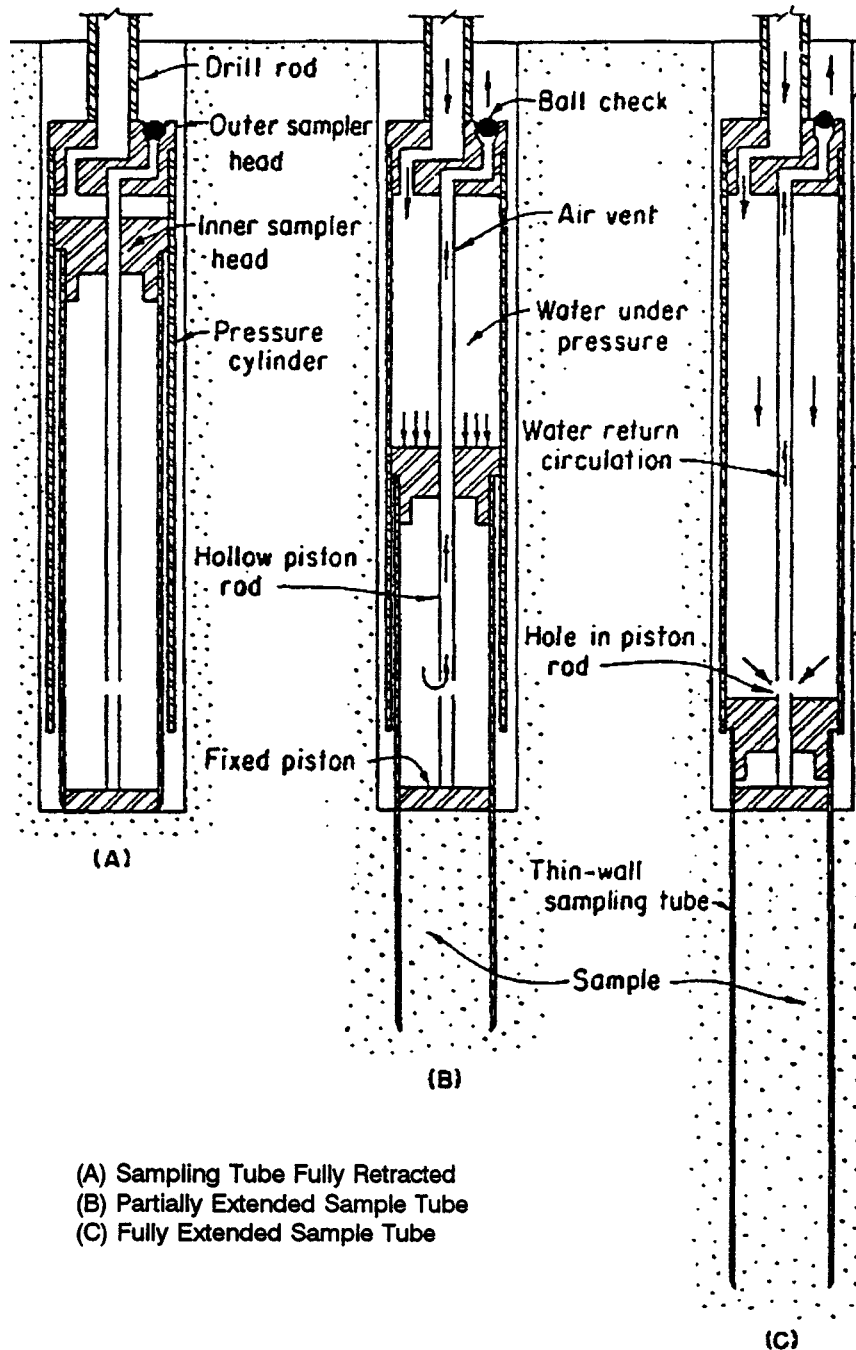

(A) Sampling Tube Fully Retracted
(B) Partially Extended Sample Tube
(C) Fully Extended Sample Tube

FIG. 1 Sampler in Operation

volume changes in the sampling process, due to drainage⁶. The hydraulically activated stationary piston sampler is generally not effective for cohesive formations with unconfined, undrained shear strength in excess of 2.0 tons per square foot, coarse sands, compact gravelly tills containing boulders and cobbles, compacted gravel, cemented soil, or solid rock. These formations may damage the sample or cause refusal to penetration. A small percentage of gravel or gravel cuttings in the

⁶ Marcossion and Bieganovsky, "Liquefaction Potential of Dams & Foundations, Report 4, Determination of In situ Density of Sands," *Research Report S-76-2*, U.S. Army Engineer Water Way Experimental Station, Vicksburg, MS, 1977.

base of the borehole can cause the tube to bend and deform, resulting in sample disturbance. Certain cohesive soils, depending on their water content, can create friction on the thin-walled tube which can exceed the hydraulic delivery force. Some rock formations can weather into soft or loose deposits where the hydraulically activated stationary piston sampler may be functional. The absence of ground water can affect the performance of this sampling tool. As with all sampling and borehole advancement methods, precautions must be taken to prevent cross-contamination of aquifers through migration of contaminants up or down the borehole. Refer to Guide D 6286 on selecting drilling methods for

environmental site characterization for additional information about work at hazardous waste sites.

6. Criteria for Selection

6.1 Important criteria to consider when selecting the hydraulically activated stationary piston sampler include the following:

- 6.1.1 Size of sample.
- 6.1.2 Sample quality (Class A, B, C, or D) for physical testing. Refer to Practices D 4220.
- 6.1.3 Sample handling requirements such as containers and preservation requirements.
- 6.1.4 Soil conditions anticipated (cohesiveness).
- 6.1.5 Ground-water depth anticipated.
- 6.1.6 Boring depth required.
- 6.1.7 Chemical composition of soil and contained pore fluids.
- 6.1.8 Available funds.
- 6.1.9 Estimated cost.
- 6.1.10 Time constraints.
- 6.1.11 History of tool performance under anticipated conditions (consult experienced users and manufacturers).
- 6.1.12 Site accessibility.
- 6.1.13 Decontamination requirements.

7. Apparatus

7.1 The hydraulically activated stationary piston sampler (Fig. 2) consists of an outer barrel, an outer barrel head with threaded connection for drill rod with a fluid-injection port leading into the inner barrel, a fluid-exit port fitted with a check valve, a friction clutch assembly to control rotation, a piston rod that attaches to the sampler head and serves as a conduit from the base of the piston for the discharge of fluid, an inner sampler head which slides over the piston rod to which the thin-walled tube is attached, a piston that attaches to the lower end of the piston rod, a thin-walled tube, and in some cases a removable outer barrel shoe. Necessary expendable supplies are thin-walled tubes, tube sealing material, sample containers for use in field extrusion, and O-ring seals.

7.1.1 *Thin-walled Tube*—The hydraulically activated stationary piston sampler is designed to accommodate standard sized 3.0-in. (76.2-mm) diameter thin-walled tubes. Samplers are also available to utilize 5.0-in. (127.0-mm) diameter thin-walled tubes as well (Fig. 3). The thin-walled tubes are generally manufactured in accordance with Practice D 1587. Thin-walled tube retaining fastener patterns may vary (Fig. 3). The most desirable pattern is the one recommended in Practice D 1587. Regardless of the pattern used, a minimum of four fasteners should be utilized to provide sufficient strength to resist any rotation or extraction forces. Sealing of thin-walled tube ends should be completed in accordance with Practice D 1587 and with Practices D 4220.

7.1.2 *Sample Tube*—Thin-walled tubes are available in various types of materials, including stainless steel, galvanized steel, and brass. There are also different types of materials that can be used to coat the tube surfaces. When using thin-walled tubes in areas with chemically contaminated soil, consideration should be given to the effect these chemicals may have on the tube composition. The reaction of the chemical with the

thin-walled tube may affect the sample properties as well as storage procedures. Samples for geotechnical testing require certain minimum volumes and specific handling techniques. Practices D 4220 offers guidance for handling samples submitted for physical testing.

7.2 *Power Sources*—Hydraulic activation of the stationary piston sampler requires a power source to supply fluid or air to the sampler. Rotary drilling equipment fitted with fluid pumps or air compressions may be used. The drill rig should have a tower for placing and removing the sampler from the borehole. The drill rig should also have sufficient retraction power to extract the full sample tube, overcoming the suction and the friction of the formation soils. The fluid pump should be capable of supplying 200 psi (1380 kN/m²). Piston, progressive cavity, and peristaltic pumps work well. The pump should be equipped with a pressure-relief valve set at a minimum of 200 psi. Air compressors capable of delivering 175 psi (1207.5 kN/m²) are acceptable. Pressure requirements are governed by the soil resistance values of the formation being sampled. Drilling tools needed to operate the sampler include drill rods to position the sampler and to transfer the activation fluid, rod-handling tools, pipe wrenches, fluid swivels, and so forth; casing or hollow stem augers to provide a stable borehole; a pipe vise to secure the sampler for thin-walled tube removal and loading; wood blocks for reloading the thin-walled tube into the sampler barrel without damage to the cutting edge; hand tools to remove and install the tube fasteners; and a brush with buckets for cleaning the sampler.

7.2.1 *Rotary Drilling Equipment*—Drills are required that are capable of performing drilling functions in accordance with Practice D 6151 and Guide D 5783. Drill units generally offer a ready hydraulic system for the retraction of samplers from the sampled formation and downward thrust for pushing the sampler through minimal amounts of borehole cave-in to reach desired sampling depth as well as reactive weight to counteract the thin-walled tube discharge pressure. Because most drills are equipped with leveling jacks, better weight application is achieved. Vertical pushing is improved because of the ability to level the machine. Tool handling is facilitated by high-speed winches common to drilling rigs, extended masts for long tool pulls, and sampler holding devices. Drill units are commonly fitted with fluid pumps that will provide the activation fluid. The unit must have a working pressure measurement gage in the fluid discharge line positioned where it can be easily read. This gage will be the indicator of how the sampler is functioning as well as when the thin-walled tube has been fully extruded.

7.3 *Activation Fluid*—The generally accepted activation fluid for using the hydraulically activated stationary piston sampler is clean water. The sealing areas inside the sampler have tight tolerances and as such cannot tolerate many physical impurities. The use of regular drilling water that is contaminated with drill cuttings can impair the operation of the sampler and cause damage to the seal system. Water containing drill fluid additives can be used to activate the sampler. However, this fluid must also be free of foreign particles. In certain cases it may be advantageous to use drilling fluid additives such as when the injection of clean water may negatively affect

ITEM	QTY.	NAME
1	1	HEAD OSTERBERG SAMPLER BODY
2	1	Q.H. BALL
3	1	ASSY BARREL OSTERBERG SAMPLER
4	1	PISTON OSTERBERG SAMPLER UPPER
5	1	ROD OSTERBERG ACTUATING
6	1	3" X 36" SHELBY TUBE-GALV
7	1	PISTON OSTERBERG SAMPLER LOWER
8	1	PIN ROLL 3/16 X 2
9	3	ROLLER OSTERBERG SAMPLER
10	3	SPRING OSTERBERG SAMPLER
11	1	PIN ROLL 1/4 X 1.00(NOT SHOWN)
12	4	SCREW SOCKET HD 3/8-16 X 5/8 (NOT SHOWN)
13	2	O-RING ACD-568-210BN70 (NOT SHOWN)
14	1	O-RING ACD-568-336BN70 (NOT SHOWN)
15	1	O-RING ACD-568-230BN70 Q.H. (NOT SHOWN)

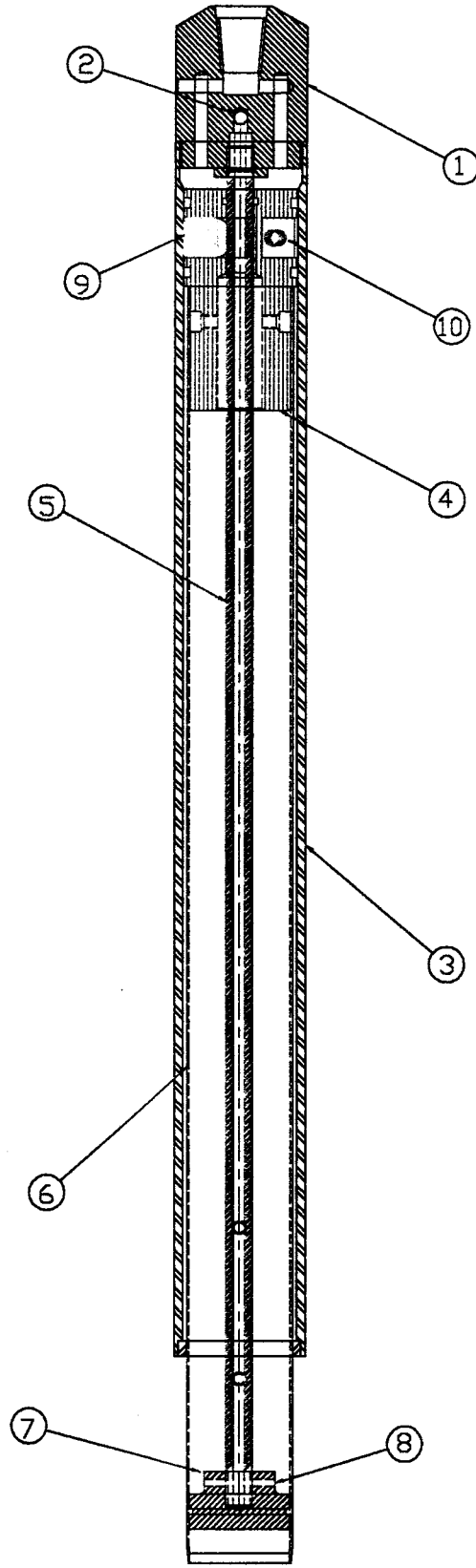

FIG. 2 Hydraulically Operated Stationary Piston Sampler

borehole stability. When using bentonite-based drill additives, a fluid of 30 to 45-s marsh funnel viscosity (API RP13B.1

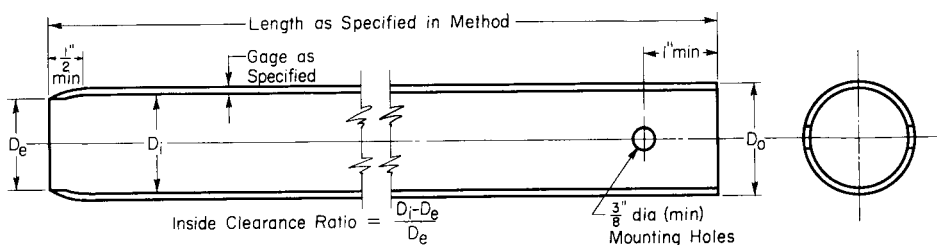

FIG. 3 Thin-Walled Tube Sampler, Practice D 1587

Standard Procedure for Field Testing Water-Based Drilling Fluids) will work adequately. However, the sampler will need to be thoroughly cleaned after each use if drill fluid additive borehole stabilization techniques are required. As the amount of drill fluid needed to activate the sampler is quite small, in the range from 5 to 10 gal depending on hole depth, the impact on borehole stability may be minor. When using air as the drill fluid it will generally be clean as it has been processed through the compressor. Refer to Guide D 5782 for additional information on air drilling. The air entering the sampler may be heated and will probably be quite dry. These conditions can affect the operation of the sampler by increasing the friction at the piston and piston rod seals.

7.4 Sample Handling—To protect the sample and retain it in its most natural state, the tube ends must be sealed and the sample immobilized in the tube. Expandable packers, correctly sized for tubes, work well. The tubes can also be cut smoothly and plastic caps attached to the ends. If the tubes are not cut, sample trimming tools will be required to remove soil from the ends for insertion of the packers. An alternative to packers might be wax-coated wooden plugs that can be inserted and waxed into contact with the sample ends.

8. Conditioning

8.1 General Cleaning—Thoroughly clean the hydraulically operated stationary piston sampler prior to being taken to the field. The unit contains several close tolerance parts that may become dysfunctional during long storage. Completely disassemble the sampler, wash all parts, inspect for damage, and replace if necessary. Apply a light film of lubricant to all parts if the sampling program allows. Silicon-based sprays and silicon grease can be applied to the O-rings. Check thin-walled tubes for roundness and conformance to the piston O-ring tolerance. Install a thin-walled tube and shop test the unit by applying air or fluid to extrude the thin-walled tube.

8.1.1 Decontamination—If the sampler is to be used on a chemically contaminated site, refer to D 1619 for recommended decontamination procedures.

8.2 Thin-Walled Tubes—Check the thin-walled tubes (Fig. 3) planned for use in the sampling program for the proper inside sample clearance ratio of 1% (maximum) of the tube diameter. The cutting edge should be sharp and not dented, nicked, or otherwise impaired. The tubes should be the prescribed length for the sampler used. Tubes that are less than the prescribed length will function, however, the sample volume will be reduced. Tubes that are longer than the prescribed length are not recommended as the tube section extending beyond the stationary piston can accumulate borehole cave-in and can be subjected to damage during insertion

into the borehole. A damaged cutting edge can ruin the integrity of the sample. The attachment fastener holes should be in the correct pattern for the sampler piston head. The fastener holes in the thin-walled tube should be free of dents, burrs, or other distortions. The fastener end of the tube should be round with flat finished edges. No dents, kinks, or other metal distortions are allowed. The body of the tube must be dent free. The interior of the tube must be smooth to slide over the piston and to accommodate the extrusion equipment. No weld seam protrusions are allowed. The interior must be rust free and clean of any accumulated dirt.

8.3 Tool Selection—Prior to dispatch to the project site make an inventory of the necessary sampler supplies. Stock and check thin-walled tubes, sample containers for field extrusion, tube sealing materials, and sampler service parts such as O-ring seals, O-ring lubricant, and tube retaining fasteners to ensure proper sustained operation for the work program prescribed. Refer to Guide D 420 for additional information on soil sampling tool selection. Materials for proper sealing of boreholes should always be available at the site.

9. Procedure

9.1 General Setup—Advance the borehole to the prescribed sampling depth using fluid or air rotary, hollow stem auger, or other accepted drill method in the necessary diameter to accommodate the hydraulically activated stationary piston sampler. Bottom discharge bits are not permitted. Side discharge as well as diffused jet discharge are generally acceptable. Drilling techniques used must keep the surface of the sampling zone as undisturbed as possible. Remove the drilling tools from the borehole^{7,8}.

9.1.1 Tool Preparation—Inspect the hydraulically activated stationary piston sampler. Inspect the check valve to be sure it is not obstructed. Load the thin-walled tube into the sampler. Slide the thin-walled tube over the sampler piston and align the fastener holes with the fastener sockets in the piston head. Insert the fasteners and tighten securely. Elevate the sampler and set the sharp edge of the tube on a non-damaging surface such as a block of wood. Apply down pressure on the top of the sampler to force the thin-walled tube into the sampler barrel the full length of the tube. Tube insertion will cease when the piston reaches the end of its upward travel or when the lower lip of the thin-walled tube reaches the base of the piston. There

⁷ *Earth Manual*, Part 2, U.S. Department of the Interior, Bureau of Reclamation, 1990.

⁸ Bosscher, Peter and Ruda, Thomas C., *Drillers Handbook*, National Drilling Assn., 3008 Millwood Ave., Columbia, SC 29205, 1990.

will be approximately ½ in. (12.7 mm) of the thin-walled tube protruding ahead of the sampler piston. Use caution in handling the sampler to avoid personal injury from the sharp edge as well as to prevent damage to this cutting edge while placing the sampler into the borehole.

9.2 Sampler Insertion—Attach the sampler assembly to the drill rod tool string. Tighten the sampler/rod joint tightly to avoid any leakage at the joint. Lower the sampler to the base of the borehole. Record the assembly length so it can be added to the length of the drill rod string to determine the exact position of the sampler. Measure the actual sampler location in the borehole to determine if any cave-in has occurred and to determine the sampler location in relation to the desired sampling depth. If minimal borehole cave-in has occurred and soil conditions allow, apply down pressure to the drill rod string to displace the cuttings or slough. Because the thin-wall tube is sealed by the piston, the tube will remain free of soil intrusion. However, forcing the sampler through cave-in may disturb the top of the sampling zone. If the sampler can not be advanced to the desired depth in this manner, it may be necessary to re-drill the borehole or use borehole stabilization techniques such as pressure equalization or casing installation. Under certain conditions, the thin-walled tube can be discharged through the cave-in into the undisturbed soil. Accurate measurement must be taken if this technique is used to determine actual sampling depth and to verify the amount of disturbed material in the sample.

9.3 Activation—With the sampler at a desired location in the borehole, connect the drill and the fluid injection swivel to the drill rod string. Put a slight amount of down pressure on the rod string to prevent any upward movement of the sampler when activation begins. Upward movement of the sampler could result in less recovery and a loss of vacuum at the piston. Start the activation source, fluid or air, observing the discharge line pressure gage. Increase the pressure slowly until penetration begins to occur. Tube penetration should be slow and constant to prevent sample distortion. The pressure will generally remain constant unless stiffer or softer layers are encountered by the tube. The discharge line pressure can provide an indication of resistance to penetration of the soil being sampled. The discharge pressure should be noted and recorded on the boring log. When the inner sampler head reaches the end of its travel length, the fluid will vent at the piston rod discharge port and move through the piston rod and check valve (Fig. 1). At that point the pressure in the discharge line will drop. In some cases a rise in the borehole water level may occur. A bubble of air may also appear as the sampler activation fluid is released from the sampler. The thin-walled tube is now fully extended. Stop the fluid or air flow immediately as no further effort is needed.

9.4 Sampler Recovery—At completion of the thin-walled tube advancement, allow the tube to remain stationary for a

minimum of 1 min. In the case of soft saturated clays, a longer waiting period may be necessary to improve sample recovery. When the stabilization period is complete, slowly rotate the tube two revolutions to shear off the sample. Slowly withdraw the sampler from the soil formation and bring it to the surface. If the soils sampled are quite soft it may be necessary to immediately cover the bottom end of the tube to prevent any specimen loss. Sample fall-out will generally occur just as the sampler clears the drill fluid. Be prepared to slide a flat object under the edge of the thin-walled tube as it clears the fluid to prevent specimen loss. An expandable packer will work well for this. Clamp the outer barrel into a vice or other holding device. Remove the tube attachment fasteners. Rotate the tube against the friction brake and pull on it simultaneously. It may require significant effort to overcome the vacuum that is created between the piston surface and the soil sample. Once the thin-walled tube is removed, process it as quickly as possible to prevent moisture loss or sample distortion. Guidelines for processing and shipping samples are outlined in Practice D 1587 and Practices D 4220. If the sample requires sealing of the ends, remove slough and seal. If packers are used, trim soil at the bottom of the tube to insert the packer. The removed soil can be used for classification and moisture determination. The sampler is then reloaded with a thin-walled tube and the procedure repeated at the next desired sampling interval.

10. Completion and Sealing

10.1 Information on the sealing of boreholes can be found in Guides D 5299, D 5782, D 5783, and D 5784. State or local regulations may control both the method and the materials for borehole sealing.

11. Record Keeping

11.1 *Field Report*—The field report may consist of boring log or a report of the sampling event and a description of the sample. Soil samples can be classified in accordance with Practice D 2488 or other methods as required for the investigation. Prepare the log in accordance with Guide D 5434 which lists the parameters required for the field investigation program. Record the sampler type as thin wall tube with hydraulically operated stationary piston sampler. List all information related to the sampling event, including depth, discharge fluid pressure, recovery, strength index readings such as pocket penetrometer taken in the end of the sample, classification of soil in the ends of sample, and any comments on sampler advancement.

12. Keywords

12.1 hydraulically activated; stationary piston; thin-walled tube

**NOTICE: This standard has either been superseded and replaced by a new version or discontinued.
Contact ASTM International (www.astm.org) for the latest information.**



The American Society for Testing and Materials takes no position respecting the validity of any patent rights asserted in connection with any item mentioned in this standard. Users of this standard are expressly advised that determination of the validity of any such patent rights, and the risk of infringement of such rights, are entirely their own responsibility.

This standard is subject to revision at any time by the responsible technical committee and must be reviewed every five years and if not revised, either reapproved or withdrawn. Your comments are invited either for revision of this standard or for additional standards and should be addressed to ASTM Headquarters. Your comments will receive careful consideration at a meeting of the responsible technical committee, which you may attend. If you feel that your comments have not received a fair hearing you should make your views known to the ASTM Committee on Standards, at the address shown below.

This standard is copyrighted by ASTM, 100 Barr Harbor Drive, PO Box C700, West Conshohocken, PA 19428-2959, United States. Individual reprints (single or multiple copies) of this standard may be obtained by contacting ASTM at the above address or at 610-832-9585 (phone), 610-832-9555 (fax), or service@astm.org (e-mail); or through the ASTM website (www.astm.org).