



# Standard Test Method for Measuring the Shear Stresses of Powders Using the Peschl Rotational Split Level Shear Tester<sup>1</sup>

This standard is issued under the fixed designation D 6682; the number immediately following the designation indicates the year of original adoption or, in the case of revision, the year of last revision. A number in parentheses indicates the year of last reapproval. A superscript epsilon ( $\epsilon$ ) indicates an editorial change since the last revision or reapproval.

## 1. Scope

1.1 This test method is applied to the measurement of the mechanical properties of powders as a function of normal stress.

1.2 This apparatus is suitable measuring the properties of powders and other bulk solids, up to a particle size of 5000 micron.

1.3 This method comprises four different test procedures for the determination of powder mechanical properties.

Test A—Measurement of INTERNAL FRICTION as a function of normal stress.

Test B—Measurement of WALL FRICTION as a function of normal stress.

Test C—Measurement of BULK DENSITY as a function of normal stress and time.

Test D—Measurement of DEGRADATION as a function of normal stress.

1.4 *This standard does not purport to address all of the safety concerns, if any, associated with its use. It is the responsibility of the user of this standard to establish appropriate safety and health practices and determine the applicability of regulatory limitations prior to use.*

## 2. Referenced Documents

### 2.1 ASTM Standards:

D 653 Terminology Relating to Soil, Rocks, and Contained Fluids<sup>2</sup>

## 3. Terminology

### 3.1 Definitions of Terms Specific to This Standard:

3.1.1 *adhesion*—shear stress between the wall sample and powder at a normal stress of zero.

3.1.2 *consolidation normal stress*—the maximal normal stress applied to the specimen for executing an yield locus.

3.1.3 *consolidation step*—shearing repeated under the consolidation normal stress until the shear stress reaches a maximum  $\tau_m$  value followed by a steady state value  $\tau_s$ . This step is performed before each shear step.

3.1.4 *degradation*—change of particle size as result of shearing.

3.1.5 *dynamic wall friction*—calculated from the measured normal stress and the steady state shear stress after certain shearing.

3.1.6 *dynamic yield locus*—line calculated from measured values of normal stress and steady values of the shear stress.

3.1.7 *peak shear stress* ( $\tau_m$ )—maximum shear stress at the beginning of yield - at the transition between elastic and plastic deformation.

3.1.8 *pre-consolidation normal stress* ( $\sigma_{np}$ )—normal stress applied during the first part of the test in order to densify the specimen.

3.1.9 *shear step*—shear after the consolidation step, performed under the normal stress which is equal to or lower than the consolidation normal stress, until the shear stress reaches the peak value followed by a steady state value  $\tau_s$ .

3.1.10 *split level*—level between the bottom and top cover of the shear cell defined by the transition of the cell base and ring where in the specimen the shear plane occurs.

3.1.11 *static wall friction*—calculated from the measured normal stress and the maximum shear stress at the beginning of yield.

3.1.12 *static yield locus*—line calculated from measured values of normal stress and peak values of the shear stress.

3.1.13 *steady shear stress* ( $\tau_s$ )—steady state shear stress during the steady state (plastic) deformation.

## 4. Summary of Test Method

### 4.1 Measurement of Internal Friction as a Function of Normal Stress:

NOTE 1—Sequence of a standard shear test (Fig. 3):

(a) The upper graph shows the change of normal stress as a function of time. Before each shear step, a consolidation normal stress  $\sigma_n$  is applied to the specimen, to reestablish the consolidation condition.

(b) The next graph shows the change of shear stress during the consolidation step and the shear step.

(c) The next graphic shows the expansion and contraction of the specimen during various test stages.

(d) The lowest graph shows the change of rotational movement of the shear tester as function of time.

4.1.1 For each individual test, the powder is compacted with the pre-consolidation normal stress. It is then pretreated by

<sup>1</sup> This test method is under the jurisdiction of ASTM Committee D18 on Soil and Rock and is the direct responsibility of Subcommittee D18.24 on Characterization for Handling of Bulk Solids.

Current edition approved June 10, 2001. Published August 2001.

<sup>2</sup> *Annual Book of ASTM Standards*, Vol 04.08.

F-normal consolidation force  
 R-radius for shear stress calculation  
 r-radius at a point of the cross section of the shear cell  
 L-radius on which the measured force is acting  
 T-measured force  
 $\tau$ -shear stress  
 M-moment of acting shear stresses

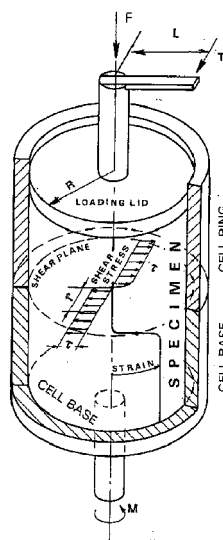

**FIG. 1 Schematic View of a Rotational Split Level Shear Cell**

applying a shear stress until steady state is achieved. The shear stress is repeatedly applied and removed until consistent results are obtained. Next, the normal stress is reduced in steps. Before each shear step, the consolidation normal stress is reapplied. The measurements provide a measure of the instantaneous static and dynamic yield loci.

4.1.1.1 During the entire shear test the height of the specimen is measured simultaneously in order to determine the compaction and expansion of the specimen.

4.1.2 The instantaneous static and dynamic yield loci are determined using the procedure outlined in the above section without any delay between the various stages of the test.

4.1.3 The time dependent static yield locus is measured as a function of time by preconditioning the specimen for various times under consolidation normal stress conditions; the peak shear stress is then measured.

4.2 *Measurement of Wall Friction as a Function of the Normal Stress*—By placing a wall specimen under the cell ring, the shear stresses (wall friction) are measured between the wall specimen and the powder.

4.2.1 The instantaneous static and dynamic friction are determined.

4.3 *Measurement of Degradation as a Function of Normal Stress*—The influence of shearing on particle degradation is measured by particle size analysis after shearing the specimen at a predetermined normal stress. Particle size degradation is measured from the change of particle size distribution before and after test (see 10.4.3).

## 5. Significance and Use

5.1 The test method is useful for the following:

5.1.1 *Classification of Powders*—The cohesion and angle of internal friction are flowability indicators of powders and can be used to classify the powders.

5.1.2 *Quality Control*—For a number of industrial applications flowability factors are used to compare the material flowability at different times during production. The material produced has to be held within given limits for each application and each powder so as to ensure trouble-free operation.

5.1.3 *Material Engineering*—Powder properties are influenced by particle size, particle size distribution, fat content, humidity and other parameters. By selecting the correct parameters and the correct mixtures of powders, the required mechanical properties of the product are achieved.

5.1.4 *Design of Handling Equipment*—For certain storage and conveyor equipment there are mathematical models exist which require the mechanical properties of powders.

## 6. Apparatus<sup>3</sup>

6.1 The Rotational Split Level Shear tester is schematically shown in Fig. 1 and the specimen is contained in the following shear cell components.

6.1.1 *Cell Base*, is cylindrical and has a knurled interior bottom surface.

6.1.2 *Cell Ring*, is a ring-formed element to be placed on the cell base.

6.1.3 *Loading Lid*, is a knurled interior cover surface for loading of the specimen, to be placed on the specimen.

6.1.4 *Shear Plane*, shown in Fig. 1, occurs at the transition plane between the cell base and the cell ring.

6.1.5 Several shear cell sizes are available to accommodate a variety of particle sizes. The selected shear cell diameter should be at least 25 times larger than the average particle diameter. The most frequently used shear cell is a nominal 60

<sup>3</sup> Available from Dr. I. Peschl, Post Box 399, NL-5600 AJ Eindhoven, The Netherlands.

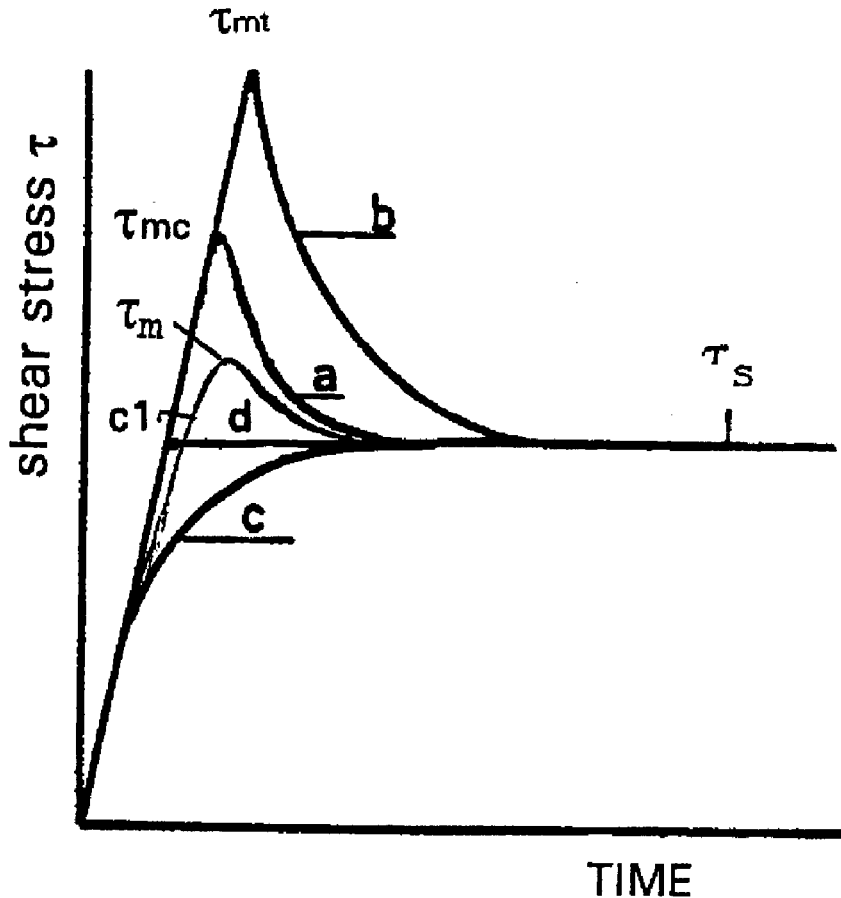

**FIG. 2 Shear Resistance as Function of Time (Angular Rotation) in Relation to the Steady Shear Stress**

mm diameter and would accommodate powders with an average particle diameter smaller than 2400 microns.

6.2 *Rotating Table*, on which the Cell Base is fixed causes the Cell Base to rotate against the Loading Lid.

6.2.1 In Fig. 1, the cross section shows the cell base, ring and loading lid. The cell base rotates. The loading lid is placed on the specimen and loaded with predetermined weights. The shear resistance is measured by measuring the moment on the loading lid.

## 7. Selection of Test Parameters

### 7.1 Sampling:

7.1.1 Prepare and store the test specimens in accordance with any valid safety and environmental regulations.

7.1.2 Prepare the specimens in accordance with the operating conditions expected during the application; i.e. temperature, humidity and other conditions. Use an adequate climate chamber to condition the specimen as necessary.

7.1.3 If a powder contains large particles which are uniformly distributed in a mixture, which otherwise meets the criteria of 6.1.5, the large particles may be sieved out. It is acceptable to sieve out the large particles until the proportion of large particles does not exceed about 5 % of the test specimen. Beyond this limit a larger diameter of the shear cell

should be used according 6.1.5 to retain the large particles in the mixture.

### 7.2 Determination of Test Parameters:

NOTE 2—The selected consolidation normal stress should match the expected stress in the actual process specified by an engineer/scientist having a knowledge of shear testing and a theoretical background.

7.2.1 For the measurement of internal friction, the consolidation normal stress is the same during both, the pre-consolidation  $\sigma_{np}$  and the consolidation steps  $\sigma_n$ . See Fig. 3.

7.2.1.1 The normal stress during the shear step is equal to or lower than the consolidation normal stress. See  $\sigma_{nx}$  in Fig. 3.

7.2.1.2 In the absence of specified values of consolidation normal stress the test should be performed with consolidation normal stress of 5.0 kPa, 15.0 kPa and 25.0 kPa.

7.2.1.3 In the absence of specified values of normal stress during the shear steps the test should be performed with normal stress equal to 100 %, 80 %, 60 %, 40 % and 20 % of the consolidation normal stress.

7.2.2 The measurement of density is performed by applying the predetermined normal stress to the specimen (see 7.2.1). In the absence of specified values for normal stress, the test should be performed at 1 kPa, 5 kPa, 10 kPa, 15 kPa, 25 kPa, 15 kPa, 10 kPa, 5 kPa, and 1 kPa.

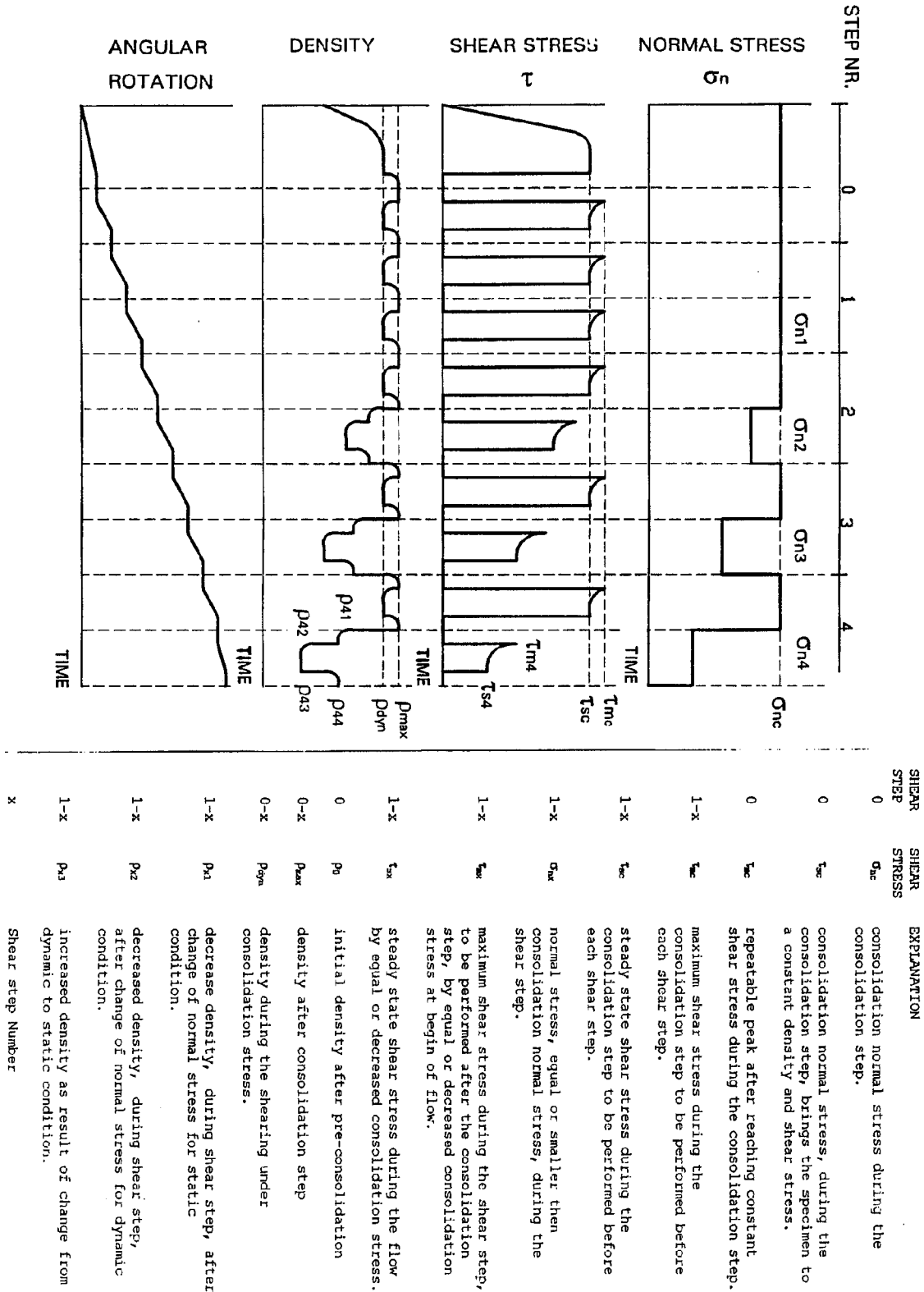

FIG. 3 Sequence of a Shear Test

7.2.3 The measurement of wall friction is performed by applying the predetermined normal stress to the specimen. In the absence of specified values for normal stress, the test should be performed at 1 kPa, 10 kPa, 15 kPa and 25 kPa.

7.2.4 The degradation test should simulate the normal stress and time during which the shearing takes place. For a good simulation, a number of such steps might be necessary in order to simulate the stresses and the time during which they are

acting throughout the whole process. In the absence of specified values for normal stress, the test should be performed at 5 kPa during 10 min.

## 8. Specimen Preparation for Measurement

8.1 *Preparation for the Measurement of the Internal Friction—Shear Test* (Fig. 5):

8.1.1 Place the shear cell ring on top of the cell base. Center the shear cell ring with the three centering screws.

8.1.2 Determine the mass of the empty shear cell including the shear cell ring. Use a scale with the accuracy of 0.1 gram.

8.1.3 Place the fill ring on top of the shear cell ring.

8.1.4 Fill the shear cell, as uniformly as possible, with powder to be tested. Use a sieve for filling the shear cell in order to remove lumps and agglomerates from the specimen.

8.1.5 Scrape off the surplus material in small amounts by scraping off with a blade as shown in Fig. 10. The blade should be scraped across the ring with a zigzag motion. Prevent downward forces from acting on the specimen.

8.1.6 Center the consolidation lid on top of the material in the shear cell.

8.1.7 Load the specimen uniaxially by placing weights on the consolidation lid so as to achieve a pre-consolidation normal stress corresponding to one of the predetermined consolidation normal stresses specified in 7.2.

8.1.8 Consolidate the powder with the predetermined pre-consolidation normal stress until the consolidation is completed. The time required to consolidate the specimen will vary with the material. Take 10 min for the first trial.

8.1.9 Remove the weights, consolidation lid and the fill ring.

8.1.10 Perform 8.1.5.

8.1.11 Determine the mass of the shear cell filled with powder.

8.1.12 Calculate the mass of material in the shear cell by subtracting the net value in 8.1.2 from value in 8.1.11.

8.1.13 Place the loading lid assembly on the cell base and

- $\tau$  - shear stress
- $\sigma_1$  - major principal stress
- $\sigma_3$  - minor principal stress
- $\sigma_n$  - normal stress
- $\sigma_d$  - unconfined compressive strength for instantaneous yield locus
- $\sigma_{dt}$  - unconfined compressive strength for time yield locus
- $\tau_{mt}$  - top shear stress for time consolidation
- $\tau_{mx}$  - peak shear stress for instantaneous measurement
- $\tau_{sx}$  - steady state shear stress during the steady state (plastic) deformation

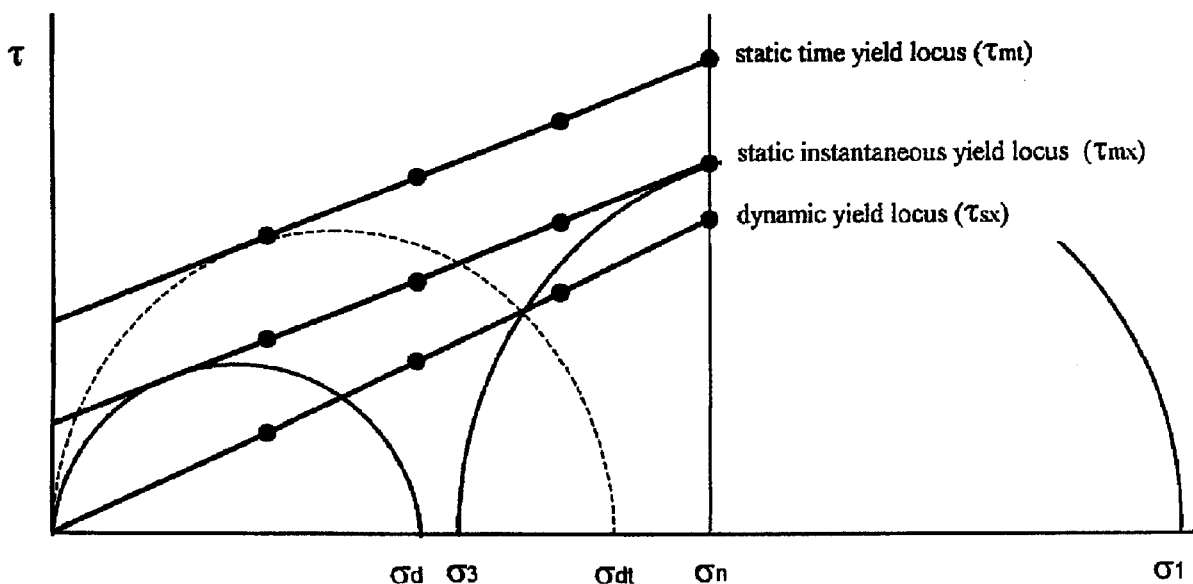
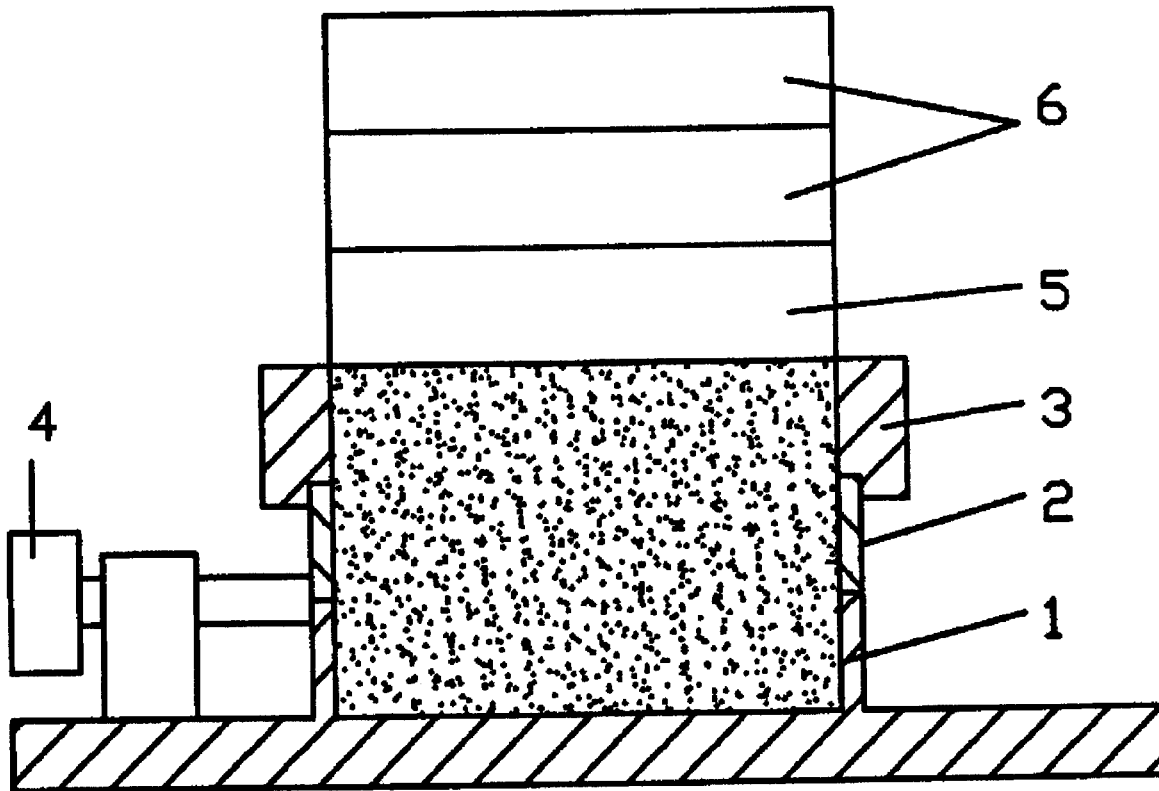

FIG. 4 Instantaneous and Time Yield Loci

- 1 Cell base
- 2 Shear cell ring
- 3 Fill ring
- 4 Centering screws
- 5 Consolidation lid
- 6 Weights



**FIG. 5 Shear Cell Assembly for Filling**

tighten the three clamp screws.

**8.2 Preparation for Measurement of Wall Friction:**

8.2.1 Mount the specimen of wall material on the cell base and secure it with the centering screws as shown in Fig. 7.

8.2.2 Place the cell ring on the wall specimen.

8.2.3 Perform 8.1.4-8.1.10 and 8.1.13.

**8.3 Preparation for Measuring the Density :**

8.3.1 Perform 8.1.1-8.1.4.

8.3.2 Remove the fill ring.

8.3.3 Perform 8.1.5 and 8.1.11-8.1.13.

**8.4 Preparation for Measurement of Degradation:**

8.4.1 Perform a sieve analysis or particle size analysis, before running the degradation test.

8.4.2 Prepare the shear cell in accordance with 7.2.4.

8.4.3 Perform 8.1.1-8.1.13.

**9. Procedures for Executing the Test**

NOTE 3—The procedures are similar for carrying out manual and automatic testers. Both shear testers can be controlled by hand or by computer, only in the case of the manual shear tester should the weight be changed manually.

**9.1 Mount the Shear Cell on the Turntable of the Shear Tester:**

9.1.1 Place the shear cell assembly on the shear tester as shown in Fig. 6.

9.1.2 Tighten the clamp screws of the turntable.

9.1.3 Loosen the three centering screws which center the cell ring on the cell base.

**9.2 Measurement of the Internal Friction as a Function of Normal Stress and Time:**

NOTE 4—The number and value of the shear steps for one yield locus, should be determined by an engineer in accordance with 7.2.

9.2.1 Place weights on top of the shear cell corresponding to the consolidation normal stress ( $\sigma_n$  in Fig. 3) for yield locus to be measured.

9.2.2 Shear the specimen by rotating the cell base relative to the loading lid in the direction in which the arm of the loading lid press against the load cell. Observe until the shear force reaches a steady value for at least 1 min.

9.2.3 Reverse the rotational shear direction and observe the shear force. After the shear force drops to zero, continue the

- 1 Turntable
- 2 Cell base
- 3 Clamp screws for fixing the cell to turntable
- 4 Centering screw for shear cell ring
- 5 Cell ring
- 6 Loading lid

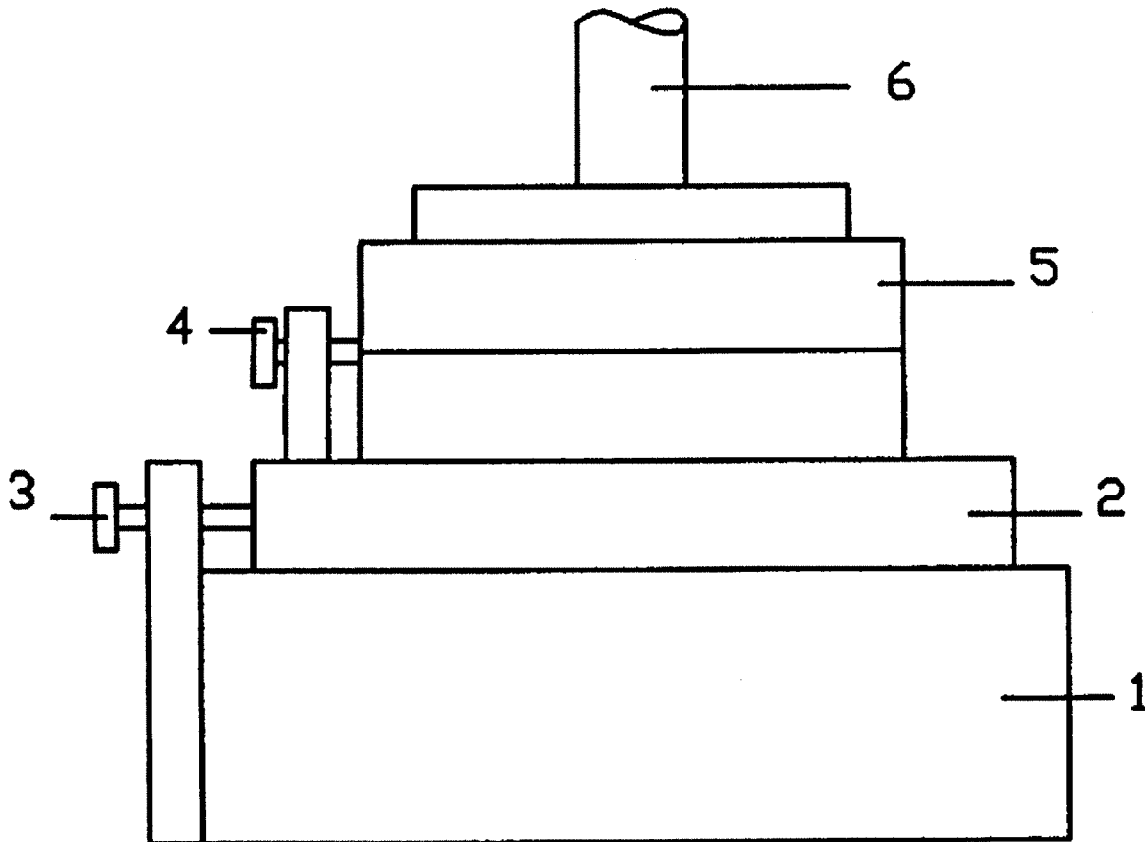

**FIG. 6 Shear Cell Assembly Mounted on Shear Tester**

reverse rotation for approximately 10 s and then stop.

9.2.4 Shear the specimen in the forward direction. Observe the peak at the beginning of shearing. Wait until a steady value is maintained for at least 1 min.

9.2.5 Perform 9.2.3.

9.2.6 Repeat 9.2.4 and 9.2.5 until the peak at the beginning of shearing is no higher than the previous peak.

9.2.7 Change the weight according to the predetermined normal stress for the shear step to be performed (see 7.2).

9.2.8 Shear the specimen by rotating in the forward direction. Wait until the peak of the shear force is reached.

9.2.9 Perform 9.2.3.

9.2.10 Repeat 9.2.1-9.2.3 and 9.2.7-9.2.9 until all required shear steps are carried out.

**9.3 Measurement of the Time Dependent Internal Friction—Time Consolidation Tests:**

9.3.1 To prepare the test specimen carry out the procedures specified in 9.2.1-9.2.4.

9.3.2 Use one of the following methods to allow the specimen to adjust to applied stresses.

**NOTE 5**—Method 1 approximates more closely the stress conditions which exist in reality; however, it requires continued use of the shear tester or a special consolidation bench. Method 2 is more practical, especially when large numbers of tests are required, or when the tests are carried out under special conditions, e.g. high temperature or humidity. The test results of these two methods differ because of the direction and value of the stresses during the consolidation time are different.

**9.3.2.1 Method 1**—With the shear cell in the shear tester. Stop the shear deformation. After the consolidation time, remove the shear stress and change normal stress according to the next shear step to be measured. During the waiting period, some relaxation may occur which will alter the stress state.

**9.3.2.2 Method 2**—Perform 9.2.3. Remove the shear cell from the shear tester and place it on a consolidation bench. Apply a normal stress to the specimen which is equal to the major principal stress,  $\sigma_1$ , as determined from the instantaneous static yield locus at the consolidation normal stress (Fig. 4). After the required waiting time, remove the normal stress, return the shear cell to the shear tester and apply the required normal stress for the next shear step.

- 1 Wall sample
- 2 Cell ring
- 3 Cell base
- 4 Centering screws

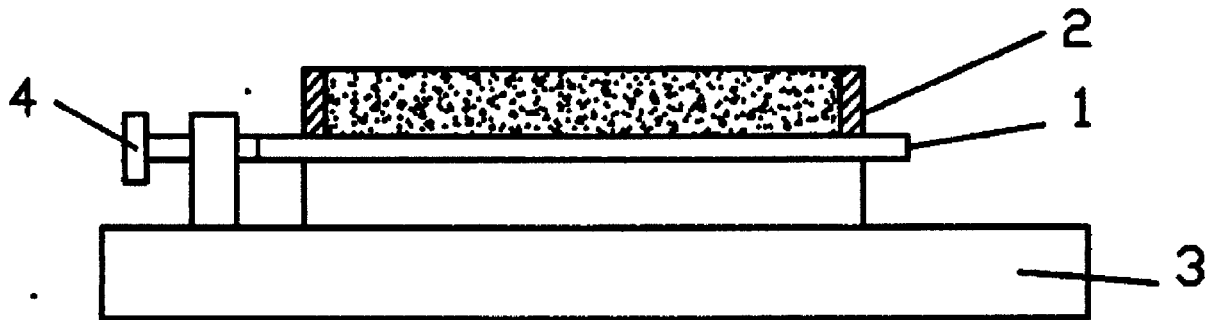

**FIG. 7 Shear Cell Assembly for Measurement of Wall Friction**

9.3.3 Perform the procedures specified in 9.2.7-9.2.9 in order to measure the shear resistance.

9.3.4 Repeat 9.3.1-9.3.3 for each of the required shear steps for each consolidation time.

9.4 *Measurement of Wall Friction as Function of Normal Stress:*

9.4.1 Apply the predetermined normal stress to the specimen, in accordance to 7.2.

9.4.2 Perform 9.2.2.

NOTE 6—The above procedure assumes that the wall surface sample has uniform frictional properties in all directions. When the wall surface has directional frictional attributes, a deviation of true wall friction value can be expected.

9.4.3 Record and observe on the strip chart recorder the development of shear stresses during shearing. When the shear force reaches a constant value perform 9.2.3.

9.4.4 Perform 9.2.2.

9.4.5 Observe the development of the shear force until the shear value reaches a maximum value followed by a lower steady value. Perform 9.2.3.

9.4.6 Repeat 9.4.4 and 9.4.5 until the peak at the beginning of shearing reaches a maximum value.

9.4.7 Perform 9.2.3.

9.4.8 Change the weight according to the normal stress for the next loading step.

9.5 *Measurement of Density as a Function of Normal Stress and Time:*

9.5.1 Connect the strip-chart recorder.

9.5.2 Connect the displacement transducer to the shear cell for measurement of the height of the specimen.

9.5.3 Place the predetermined weight, corresponding to the predetermined normal stress, on the specimen.

9.5.4 Observe until the compaction is finished.

9.5.5 Replace the weight corresponding to the next predetermined normal stress.

9.5.6 Repeat 9.5.4 and 9.5.5 for all predetermined normal stresses.

9.6 *Measurement of Degradation as a Function of Stress:*

9.6.1 Perform 7.2.4.

9.6.2 Perform 9.2.2.

9.6.3 Continue to shear for the predetermined degradation time.

9.6.4 Perform 9.2.3.

9.6.5 Change the weight corresponding to the normal stress for the next degradation step.

9.6.6 Repeat 9.6.2-9.6.5 until all steps have been completed.

9.6.7 Remove specimen and measure particle size distribution.

## 10. Evaluation of Test Results

10.1 *Internal Friction as a Function of Stress:*

10.1.1 Plot the shear stress versus time curves.

10.1.1.1 A plot of shear stress versus time can have several shapes. The user should identify the following features of the curves (see Figs. 2 and 3).

10.1.1.2 *Linear Increase*—Representing elastic deformation.

10.1.1.3 *Peak*—By studying several peaks from successive shearings the following types of peaks may be observed.

10.1.1.3.1 *Increasing Peak* ( $\tau_m$ )—Representing an under-consolidated sample in which the density has not reached the final value corresponding to the applied normal stresses.

10.1.1.3.2 *Repeatable Peak* ( $\tau_{mc}$ )—Representing a point on an instantaneous (static) yield locus.

10.1.1.3.3 *Nonrepeatable Peak* ( $\tau_i$ )—Representing overconsolidation or the points representing other non-repeatable effects, such as crystallization, degradation, etc. Most of these effects are a function of time and the points are on the so-referenced to as time yield locus.

10.1.1.4 *Constant Value* ( $\tau_c$ )—Representing continuous plastic deformation and the points belong to the dynamic yield locus.

10.1.2 *Calculate the Shear Stress*—Based on a uniform distribution of the shear stress over the cross section of the shear cell as shown in Fig. 1. From the integral of shear moments over the cross section we obtain:

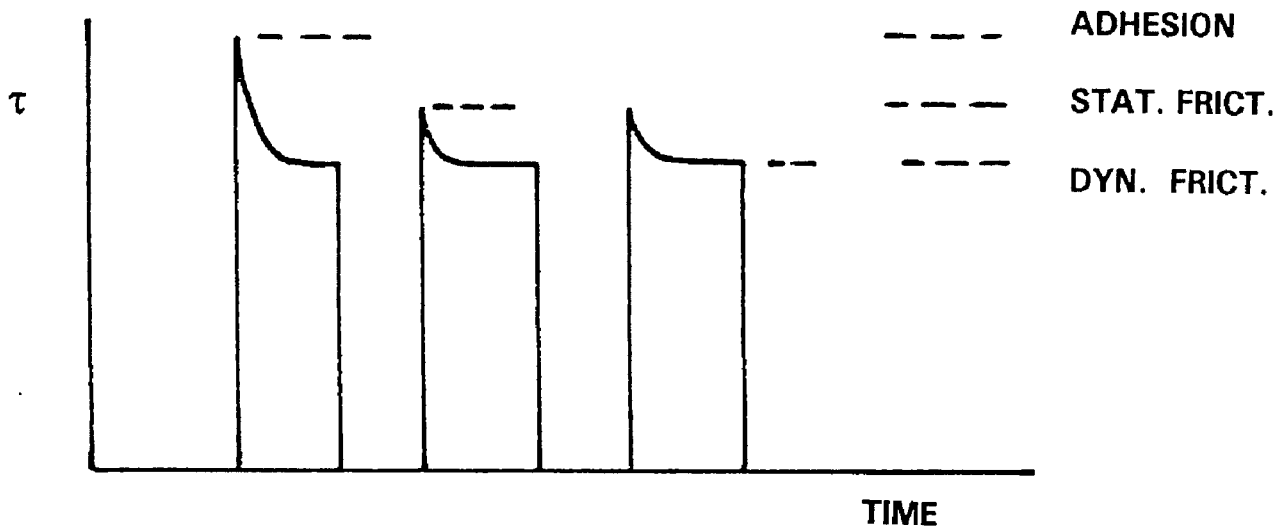
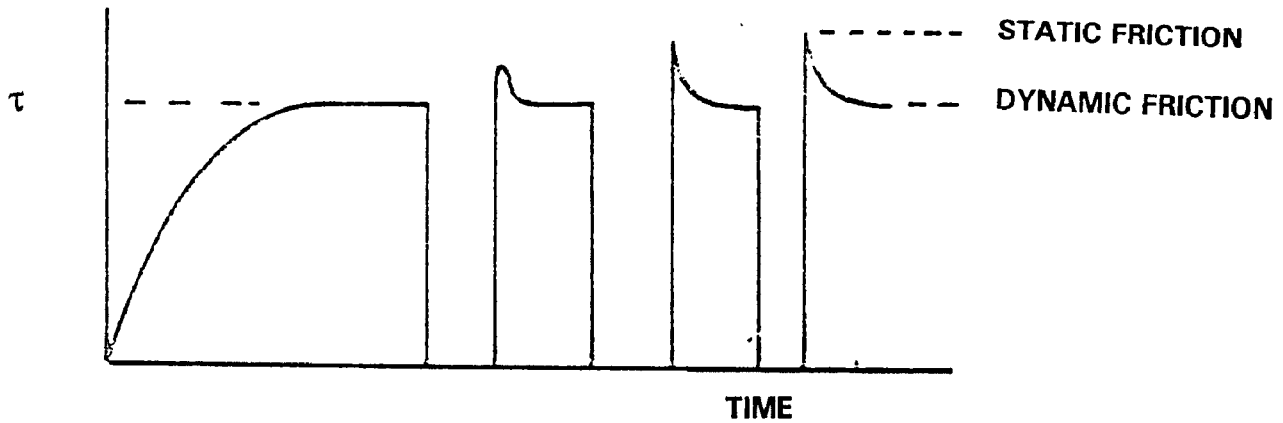

FIG. 8 Characteristic Shear Stress Development for Wall Friction—Static, Dynamic and Adhesion

$$\tau = \frac{3 * L}{2 * R} * \frac{T}{A} \quad (1)$$

where:

- τ = shear stress,
- R = radius of the shear cell,
- L = length of arm for transfer of shear torque,
- T = force measured on load cell, and
- A = cross sectional area of the shear cell.

10.1.3 Calculate the Normal Stress at the Mid Height of the Specimen:

NOTE 7—The correction of vertical load is recommended for powders with density greater than 1 g/cm<sup>3</sup>. For powders with density less than 0.5 g/cm<sup>3</sup> it can be ignored.

$$\sigma_n = \frac{F_n + F_{ncor}}{A} \quad (2)$$

where:

- A = cross sectional area of the shear cell,
- σ<sub>n</sub> = normal stress,
- F<sub>n</sub> = vertical load, and
- F<sub>ncor</sub> = correction to vertical load for weight of powder above the shear plane.

10.1.4 Correct the Peak Shear Stress for Variation in Steady Shear Stress:

NOTE 8—The steady shear value of the consolidation step should be the same for all measured points of a yield locus. The variation can occur as a result of small differences in the density, and systematic error of the shear tester. If the variation is greater than 1 % of the value of the consolidation normal stress, the measured points can be corrected according to the average of the shear stresses at the consolidation normal stress.

$\sigma_{n1} - \sigma_{n4}$  - LOAD STEPS

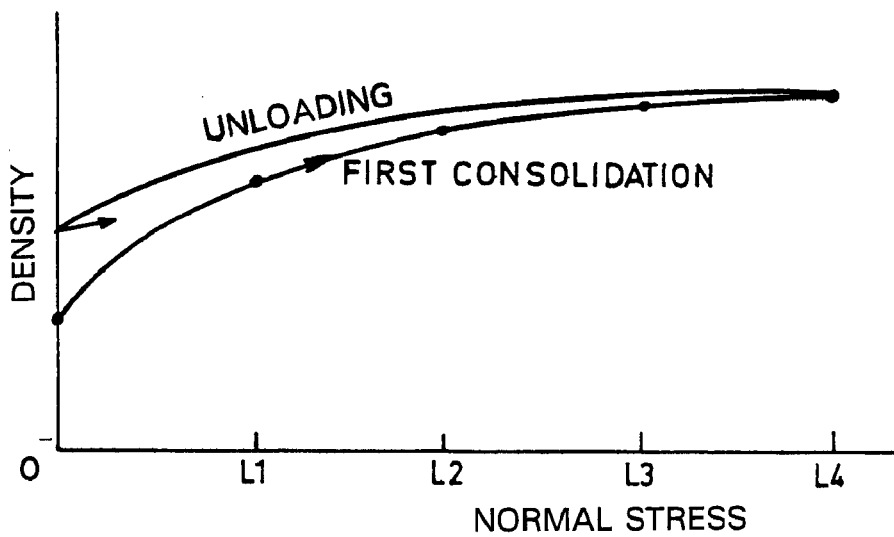
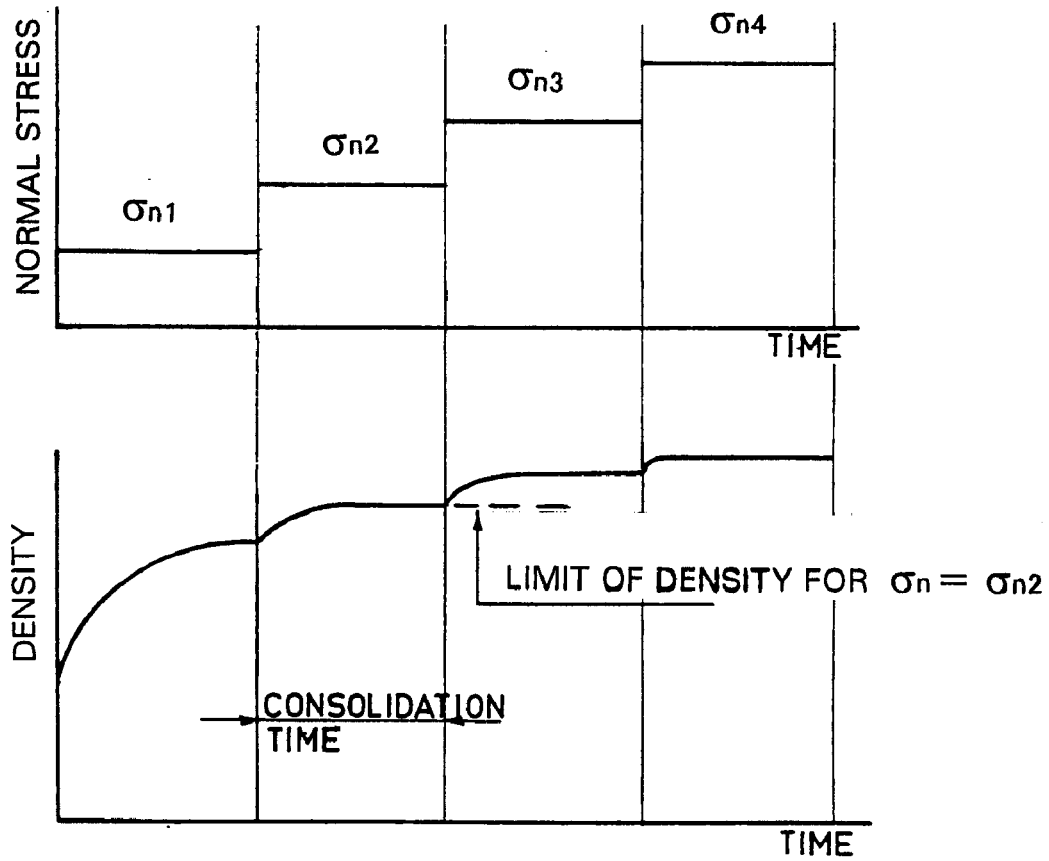

FIG. 9 Schematic Diagram of Measurement of Density

$$\tau_{peak-cor} = \tau_{peak} * \frac{\tau_{stat-av}}{\tau_{stat}} \quad (3)$$

- 1 SCRAPER
- 2 SHEAR CELL

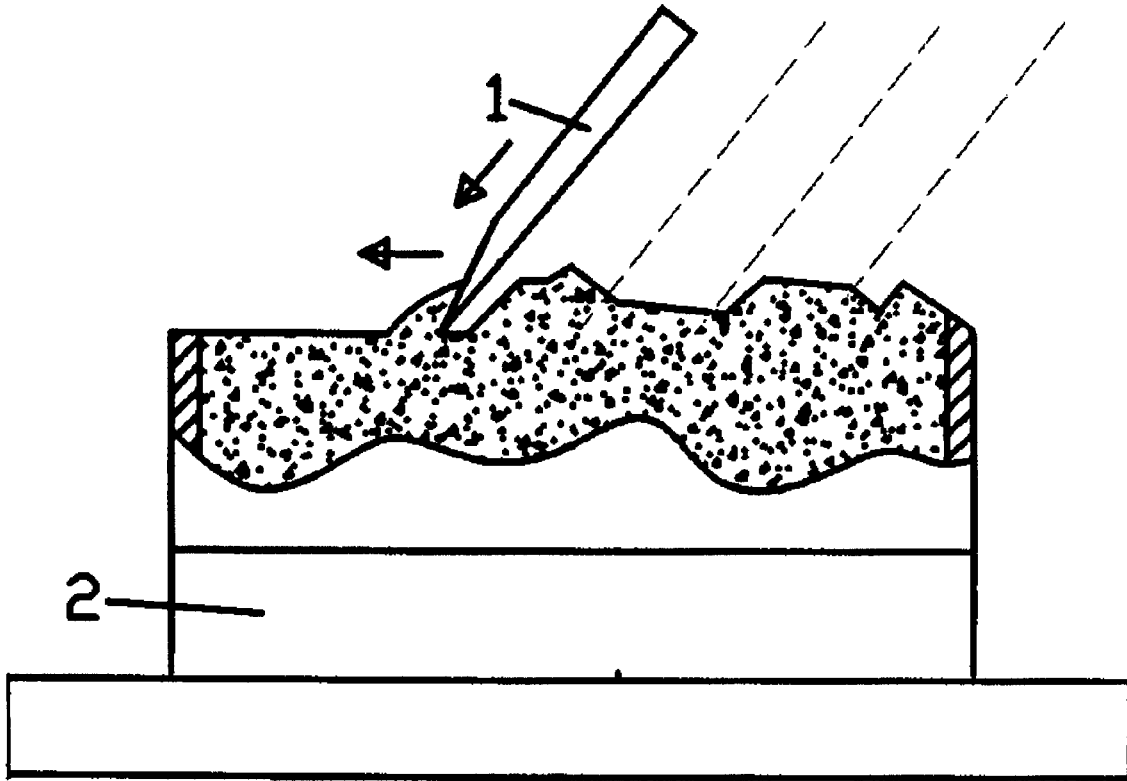

FIG. 10 Scraping the Surplus Powder

where:

- $\tau_{stat}$  = measured steady value for the shear step,
- $\tau_{peak}$  = measured peak value for the shear step,
- $\tau_{stat-av}$  = average of steady values for all shear steps, and
- $\tau_{peak-cor}$  = corrected peak value for the shear step.

10.1.5 Calculate the yield locus using a best fitting linear approximation of measured points as shown in Fig. 4.<sup>4</sup> For detailed explanation see Ref. (1).

NOTE 9—The consolidation Mohr circle is tangent to the yield locus and passes through the measured shear stress for the consolidation normal stress.

NOTE 10—The unconfined compressive strength is the major principal stress of a Mohr circle passing the origin and tangent to the yield locus. The points left from the tangent can differ from straight line and should not be used for linear approximation.

$$\tau = c + \sigma * \tan\phi \quad (4)$$

<sup>4</sup> Alternative methods of constructing the (consolidation) steady state Mohr circle have been proposed. See Ref. (2).

$$\tau_n = c + \sigma_n * \tan\phi \quad (5)$$

$$\sigma_1 = \sigma_n + \tau_n * (\tan\phi + 1/\cos\phi) \quad (6)$$

$$\sigma_3 = \sigma_1 - 2 * \tau_n / \cos\phi \quad (7)$$

$$\sigma_d = 2 * c * \tan(45 + \phi/2) \quad (8)$$

where:

- $c$  = the cohesion,
- $\phi$  = the angle of internal friction,
- $\sigma_1$  = major principal stress,
- $\sigma_3$  = minor principal stress,
- $\sigma_n$  = normal stress,
- $\tau_n$  = shear stress when  $\sigma = \sigma_n$ , and
- $\sigma_d$  = unconfined compressive strength.

10.1.6 Presentation of the Measured Points in the Mohr Diagram:

10.1.6.1 Static Yield Locus—The line passing through the peak values, at the transition between the elastic and plastic deformation of all measured points, forms the static yield locus. The highest point on the yield locus is the peak measured at the consolidation normal stress. The consolidation Mohr

circle is tangent to the yield locus and passes through the measured shear stress for the consolidation normal stress. Points to the left of the tangent point of the Mohr circle through the origin result in a non linear curve and, except for special studies, these points should be not used.

10.1.6.2 *Dynamic Yield Locus* contains the measured steady state shear points, which are the shear stresses during the movement. The dynamic yield locus crosses the  $\tau$ -axes at the origin or slightly above the origin. Consequently, the cohesion is very small.

10.1.6.3 *Time-Consolidation Yield Locus*—The points passing through the non repeatable peak values form the time-consolidation yield locus. The time-consolidation yield loci are most often parallel to the instantaneous static yield locus, but in a higher position. As shown in Fig. 4, the position of the time-consolidation yield loci are higher for longer consolidation time.

10.1.6.4 *Unconfined Compressive Strength* is the major principal stress of a Mohr circle passing the origin and tangent to the yield locus.

10.1.6.5 *Yield Loci for Different Test Conditions*—In Fig. 4, a family of yield loci for different consolidation normal stresses is shown. The peaks ( $\tau_{mc}$ ), represent the points of instantaneous static yield loci. The measured steady values ( $\tau_s$ ) after each peak value ( $\tau_{mc}$ ), of all points of all yield loci are on the same line, referenced to as dynamic yield locus, and these values usually form a straight line passing the  $\tau$ -axis at the origin or slightly above the origin. The position of the instantaneous static yield locus represents the resistance at the beginning of flow and the dynamic yield locus represents the resistance during the flow. For the time yield locus the same dynamic yield locus is valid.

10.2 *Wall Friction as a Function of Normal Stress* (Fig. 8): Calculate coefficient of friction:

$$\mu = \frac{\tau}{\sigma_n} \quad (9)$$

where:

$\mu$  = coefficient of friction.

10.2.1 *Static Friction*—Several measurements for each load step are required until the peak representing the static friction reaches a maximum value. To recognize whether the peak represents the static friction or the adhesion it is necessary to repeat the measurement a number of times. If, after the first peak the value of the peak decreases, then the first peak represents the adhesion.

10.2.2 *Dynamic Friction*—The dynamic friction is represented by the steady state shear stress value which follows the peak.

10.2.3 *Adhesion*—The adhesion, if any, is the measured peak for the first shear. To recognize whether the peak represents the static friction or the adhesion, it is necessary to repeat the measurement a number of times. If the first peak grows or remains constant, the highest succeeding peak repre-

sents the static friction. If, after the first peak the value of the peak decreases, the first peak represents the adhesion.

10.3 *Density as Function of Normal Stresses*—Use the recorder to plot or the computer printout as shown in Fig. 9 for direct presentation of the test results. Calculate the density for each of the chosen normal stresses:

$$\gamma = \frac{W}{A \times H} \quad (10)$$

where:

$\gamma$  = density,

$A$  = area of the shear cell,  $\text{cm}^2$ ,

$H$  = height of the specimen, cm, and

$W$  = mass of the specimen, kg.

10.4 *Particle Degradation as Function of Shear*:

10.4.1 The relative measurement of the degradation of particles is obtained by comparing the particle size distribution before and after testing.

10.4.2 The degradation takes place only in the shear plane area. This area can be approximated to a layer 5 times the average particle size.

10.4.3 The difference between the average particle size before and after the test is a measure of the degradation.

$$Dg = \frac{D_{50(1)} - D_{50(2)}}{D_{50(1)}} \times \frac{h_{sp}}{h_{sh}} \quad (11)$$

where:

$Dg$  = degradation,

$D_{50(1)}$  = average particle size before degradation,

$D_{50(2)}$  = average particle size after degradation,

$h_{sp}$  = height of the specimen, and

$h_{sh}$  = height of the layer of the shear plane.

10.4.4 For relative measurements and comparison between two powders take  $h_{sp}/h_{sh} = 1$ .

## 11. Report

11.1 Reports should contain identification of the powder the name of operator, the date of performing the test, the consolidation time and the consolidation normal stress. If the tests have been performed under special conditions like the temperature, relative humidity, average particle size and particle size distribution and any other special circumstances they should be reported. The test results should be reported in tabular and graphic form.

## 12. Precision and Bias

12.1 *Precision*—Data will be evaluated to determine the precision of this test method. In addition, Subcommittee D18.24 is seeking pertinent data from users of this method.

12.2 *Bias*—There is no accepted reference value for this method, therefore, bias cannot be determined.

## 13. Keywords

13.1 bulk density; bulk solids; cohesive strength; degradation; flowability; internal friction; Peschl shear tester; rotational shear tester; shear stress; wall friction

**REFERENCES**

- (1) Peschl—Measurement and evaluation of the mechanical properties of powders, Powder Handling and Processing, volume 1, No. 2, June 1989.
- (2) Standard Shear Testing Method for Bulk Solids Using Jenike Shear Cell—D 6128.
- (3) Jenike A.W. Storage and flow of solids, University of Utah Engineering Experiment station, Bulletin 123, Nov 1964.

*The ASTM International takes no position respecting the validity of any patent rights asserted in connection with any item mentioned in this standard. Users of this standard are expressly advised that determination of the validity of any such patent rights, and the risk of infringement of such rights, are entirely their own responsibility.*

*This standard is subject to revision at any time by the responsible technical committee and must be reviewed every five years and if not revised, either reapproved or withdrawn. Your comments are invited either for revision of this standard or for additional standards and should be addressed to ASTM International Headquarters. Your comments will receive careful consideration at a meeting of the responsible technical committee, which you may attend. If you feel that your comments have not received a fair hearing you should make your views known to the ASTM Committee on Standards, at the address shown below.*

*This standard is copyrighted by ASTM International, 100 Barr Harbor Drive, PO Box C700, West Conshohocken, PA 19428-2959, United States. Individual reprints (single or multiple copies) of this standard may be obtained by contacting ASTM at the above address or at 610-832-9585 (phone), 610-832-9555 (fax), or [service@astm.org](mailto:service@astm.org) (e-mail); or through the ASTM website ([www.astm.org](http://www.astm.org)).*