



Standard Test Methods for Determination of the Soil Water Characteristic Curve for Desorption Using a Hanging Column, Pressure Extractor, Chilled Mirror Hygrometer, and/or Centrifuge¹

This standard is issued under the fixed designation D 6836; the number immediately following the designation indicates the year of original adoption or, in the case of revision, the year of last revision. A number in parentheses indicates the year of last reappraisal. A superscript epsilon (ϵ) indicates an editorial change since the last revision or reappraisal.

1. Scope

1.1 This test method covers the determination of soil water characteristic curves (SWCCs) for desorption (drying). SWCCs describe the relationship between suction and volumetric water content, gravimetric water content, or degree of water saturation. SWCCs are also referred to as soil water retention curves, soil water release curves, or capillary pressure curves.

1.2 This standard describes five methods (A-E) for determining the soil water characteristic curve. Method A (hanging column) is suitable for making determinations for suctions in the range of 0 to 80 kPa. Method B (pressure chamber with volumetric measurement) and Method C (pressure chamber with gravimetric measurement) are suitable for suctions in the range of 0 to 1500 kPa. Method D (chilled mirror hygrometer) is suitable for making determinations for suctions in the range of 500 kPa to 100 MPa. Method E (centrifuge method) is suitable for making determinations in the range 0 to 120 kPa. Method A typically is used for coarse soils with little fines that drain readily. Methods B and C typically are used for finer soils which retain water more tightly. Method D is used when suctions near saturation are not required and commonly is employed to define the dry end of the soil water characteristic curve (that is, water contents corresponding to suctions > 1000 kPa). Method E is typically used for coarser soils where an appreciable amount of water can be extracted with suctions up to 120 kPa. The methods may be combined to provide a detailed description of the soil water characteristic curve. In this application, Method A or E is used to define the soil water characteristic curve at lower suctions (0 to 80 kPa for A, 0 to 120 kPa for E) near saturation and to accurately identify the air entry suction, Method B or C is used to define the soil water characteristic curve for intermediate water contents and suctions (100 to 1000 kPa), and Method D is used to define the soil water characteristic curves at low water contents and higher suctions (> 1000 kPa) and

1.3 All observed and calculated values shall conform to the guide for significant digits and rounding established in Practice D 6026. The procedures in Practice D 6026 that are used to specify how data are collected, recorded, and calculated are regarded as the industry standard. In addition, they are representative of the significant digits that should generally be retained. The procedures do not consider material variation, purpose for obtaining the data, special purpose studies, or any considerations for the objectives of the user. Increasing or reducing the significant digits of reported data to be commensurate with these considerations is common practice. Consideration of the significant digits to be used in analysis methods for engineering design is beyond the scope of this standard.

1.4 *This standard does not purport to address all of the safety concerns, if any, associated with its use. It is the responsibility of the user of this standard to establish appropriate safety and health practices and determine the applicability of regulatory limitations prior to use.*

2. Referenced Documents

2.1 ASTM Standards:

- D 421 Practice for Dry Preparation of Soil Samples for Particle-Size Analysis and Determination of Soil Contents²
- D 425 Test Method for Centrifuge Moisture Equivalent of Soils²
- D 653 Terminology Relating to Soil, Rock, and Contained Fluids²
- D 698 Test Method for Laboratory Compaction Characteristics of Soil Using Standard Effort [600 kN-mJ/m³]²
- D 854 Test Method for Specific Gravity of Soils²
- D 2216 Method for Laboratory Determination of Water (Moisture) Content of Soil, Rock, and Soil-Aggregate Mixtures²
- D 3740 Practice for Minimum Requirements for Agencies Engaged in the Testing and/or Inspection of Soil and Rock as Used in Engineering Design and Construction²
- D 4753 Practice for Minimum Requirements for Agencies Engaged in the Testing and/or Inspection of Soil and Rock as Used in Engineering Design and Construction²

¹ This test method is under the jurisdiction of ASTM Committee D18 on Soil and Rock and is the direct responsibility of Subcommittee D18.04 on Hydrologic Properties of Soil and Rocks.

Current edition approved Nov. 11, 2002. Published February 2003.

² *Annual Book of ASTM Standards*, Vol 04.08.

D 5084 Test Methods for Measurement of Hydraulic Conductivity of Porous Materials Using a Flexible Wall Permeameter³

D 6026 Practice for Using Significant Digits in Geotechnical Data³

2.2 API Standard:

API RP 40 Recommended Practice for Core-Analysis Procedure⁴

3. Terminology

3.1 For common definitions of other terms in this standard see Terminology D 653.

3.2 Definitions of Terms Specific to This Standard:

3.2.1 *air entry pressure*—the air pressure required to introduce air into and through the pores of a saturated porous plate.

3.2.2 *air entry suction*, ψ_a —the suction required to introduce air into and through the pores of a saturated porous material.

3.2.3 *axis translation*—the principle stating that a matric suction ψ can be applied to a soil by controlling the pore gas pressure, u_g , and the pore water pressure, u_w , so that the difference between the pore gas pressure and pore water pressure equals the desired matric suction, that is, $\psi = u_g - u_w$.

3.2.4 *gravimetric water content*, w —the ratio of the mass of water contained in the pore spaces of soil or rock to the mass of solid particles.

3.2.5 *matric suction*, ψ —the negative gage pressure, relative to an external gas pressure acting on the soil water, that must be applied to a solution identical in composition to the soil water to maintain equilibrium through a porous membrane existing between the solution and the soil water. Matric suction is also referred to as matric potential, capillary suction, and capillary potential. By definition, matric suction is the difference between the pore gas pressure, u_g , and the pore water pressure, u_w , that is, $\psi = u_g - u_w$. In most cases the pore gas is air.

3.2.6 *osmotic suction*, ψ_o —the negative gage pressure derived from the measurement of the vapor pressure of water in equilibrium with a solution identical in composition with the soil water, relative to the vapor pressure of water in equilibrium with free pure water. Osmotic suction is also referred to as osmotic potential.

3.2.7 *porous membrane*—a porous polymeric membrane that can transmit water and has a air entry pressure exceeding the highest matric suction to be applied during a test.

3.2.8 *porous plate*—a plate made of metal, ceramic, or other porous material that can transmit water and has an air entry pressure exceeding the highest matric suction to be applied during a test.

3.2.9 *pressure chamber*—a vessel used to apply a gas pressure on the specimen and the soil pores to induce a specified matric suction.

3.2.10 *saturated water content*—volumetric or gravimetric water content when the specimen is saturated.

3.2.11 *soil water characteristic curve*—a graph of suction (matric or total) versus water content (gravimetric or volumetric) or saturation. The soil water characteristic curve is also referred to as the soil water retention curve, the soil water release curve, and the capillary pressure curve.

3.2.12 *total suction*, ψ_t —the negative gage pressure derived from the measurement of the vapor pressure of water in equilibrium with water in the soil pores, relative to the vapor pressure of water in equilibrium with free pure water. Total suction is the sum of matric and osmotic suction, $\psi_t = \psi + \psi_o$. Total suction is also referred to as total potential.

3.2.13 *volumetric water content*, θ —the ratio of the volume of water contained in the pore spaces of soil or rock to the total volume of soil and rock.

3.2.14 *water activity*, a_w —the ratio of vapor pressure of water in the soil gas to the saturated vapor pressure at the existing soil temperature. Water activity is also referred to as the relative humidity.

4. Summary of Methods

4.1 *Methods A-C*—Methods A-C yield soil water characteristic curves in terms of matric suction. Various suctions are applied to the soil and the corresponding water contents are measured. Two different procedures are used to apply the suction. In Method A, the matric suction is applied by reducing the pore water pressure while maintaining the pore gas pressure at the atmospheric condition. In Methods B and C, the pore water pressure is maintained at atmospheric pressure, and the pore gas pressure is raised to apply the suction via the axis translation principle.

4.1.1 For all three methods, saturated soil specimens are placed in contact with a water saturated porous plate or membrane. The matric suction is applied by one of the two aforementioned procedures. Application of the matric suction causes water to flow from the specimen until the equilibrium water content corresponding to the applied suction is reached. Equilibrium is established by monitoring when water ceases to flow from the specimen. Several equilibria are established at successive matric suctions to construct a soil water characteristic curve.

4.1.2 The water content corresponding to the applied suction is determined in one of two ways. For Methods A and B, the volume of water expelled is measured using a capillary tube. The water content is then determined based on the known initial water content of the specimen and the volume of water expelled. For Method C, the water content is measured gravimetrically by weighing the specimen after removal from the apparatus.

4.2 *Method D*—Method D yields a soil water characteristic curve in terms of total suction. In contrast to Methods A-C, the water content of the soil is controlled in Method D, and the corresponding suctions are measured. Two different approaches are commonly used. In one approach, a set of specimens are prepared that are essentially identical, but have different water contents. Water contents are selected that span the range of water contents that will be used to define the soil water characteristic curve. In the other approach, a single specimen is used. The specimen is tested, dried to a lower

³ Annual Book of ASTM Standards, Vol 04.09.

⁴ American Petroleum Institute, 2nd Edition, 1998.

water content, and then tested again. This process is repeated until suctions have been measured at all of the desired water contents.

4.2.1 In Method D, the water activity of the pore water is measured using a chilled mirror hygrometer (also known as a chilled mirror psychrometer) and then the total suction is computed using the Kelvin equation. In many cases, Method D is used to determine only that portion of the soil water characteristic curve corresponding to higher suctions (typically > 1000 kPa) and lower water contents. Under these conditions, the osmotic component of total suction is generally small, and the matric and total suctions are comparable. Thus, the data from Methods A-C and Method D can be combined to form a single soil water characteristic curve. An example of this type of soil water characteristic curve is provided in Section 11.

4.3 *Method E*—Method E yields a soil water characteristic curve in terms of matric suction (or capillary pressure). The specimen is contained in a support chamber that is subjected to a centrifugal force in a centrifuge. Different matric suctions are applied by varying the angular velocity of the centrifuge. Water displaced from the soil at a given angular velocity is collected and measured in a calibrated cylinder at the base of the support chamber. A soil water characteristic curve is measured by subjecting the specimen to a series of angular velocities (each corresponding to a matric suction) and measuring the volume of water displaced from the soil at each velocity.

5. Significance and Use

5.1 The soil water characteristic curve (SWCC) is fundamental to hydrological characterization of unsaturated soils and is required for most analyses of water movement in unsaturated soils. The SWCC is also used in characterizing the shear strength and compressibility of unsaturated soils. The unsaturated hydraulic conductivity of soil is often estimated using properties of the SWCC and the saturated hydraulic conductivity.

5.2 This method applies only to soils containing two pore fluids: a gas and a liquid. The liquid is usually water and the gas is usually air. Other liquids may also be used, but caution must be exercised if the liquid being used causes excessive shrinkage or swelling of the soil matrix.

5.3 A full investigation has not been conducted regarding the correlation between soil water characteristic curves obtained using this method and soil water characteristics curves of in-place materials. Thus, results obtained from this method should be applied to field situations with caution and by qualified personnel.

NOTE 1—The quality of the result produced by this standard depends on the competence of the personnel performing the test and the suitability of the equipment and facilities used. Agencies that meet the criteria of Practice D 3740 are generally considered capable of competent and objective testing, sampling, inspection, etc. Users of this standard are cautioned that compliance with Practice D 3740 does not in itself ensure reliable results. Reliable results depend on many factors. Practice D 3740 provides a means of evaluating some of these factors.

6. Apparatus

6.1 *Hanging Column Apparatus (Method A)*—A hanging column apparatus consists of three parts: a specimen chamber,

an outflow measurement tube, and a suction supply (Fig. 1). The specimen chamber consists of a glass or rigid plastic funnel containing a porous plate that is large enough to contain the specimen being tested. Such funnels are commonly referred to as “Buchner” funnels. A photograph of a funnel used for a hanging column apparatus is shown in Fig. 2. Water expelled from the specimen during the test is measuring using a capillary tube connected to the outflow end of the funnel. The other end of this capillary tube is connected to suction supply consisting of two reservoirs. The relative elevation of the two reservoirs is adjusted to develop a vacuum, which is transmitted to the capillary tube. The magnitude of the applied suction is measured with a manometer.

6.2 *Pressure Chamber (Methods B and C)*—Pressure chambers are used for the pressure extraction method to apply a gas pressure (typically air pressure) to the specimen and the gas in the pores. Typically the pressure chamber is a metallic vessel. The pressure chamber shall be pressure-rated, at the very least, for the maximum pressure to be applied to the vessel during the test. The pressure chamber shall have a sealed, non-collapsing outflow tube that connects the atmospheric pressure side of the porous plate (or membrane) to the outside of the pressure chamber. Schematics of two types of pressure chambers are shown in Figs. 4 and 5. Photographs of these pressure chambers are shown in Fig. 4. In some cases, the effects of overburden pressure may wish to be simulated. For these cases, the pressure vessel may be equipped with a piston or a triaxial cell may be used.

6.3 *Regulated Pressure Source (Methods B and C)*—A regulated pressure source is used to apply gas pressure to the pressure chamber. Compressed gas is typically provided by an air compressor or bottled gas. The pressure source and associated regulators shall be capable of maintaining the desired pressure with an accuracy of $\pm 0.25\%$ or better.

6.4 *Pressure Indicators (Methods A, B, and C)*—Pressure indicators are used to monitor the pressure applied in pressure chambers and the applied suction for the hanging column. Bourdon gages, mercury and water manometers, and pressure transducers are acceptable devices for measuring pressure in the pressure chamber. The accuracy of the measuring device must be within $\pm 0.25\%$ of the matric suction being applied. For cases where both very large and very small suctions are to be applied, multiple pressure indicators may be used to provide sufficient accuracy for the various pressures to be applied. The manometer used to measure the applied suction in Method A shall have a resolution of 1 mm of water.

6.5 *Porous Plate (Methods B and C)*—A porous plate is used in the hanging column and pressure extractor to provide a saturated interface between the pore water and the water in the volume measuring system. Porous plates shall be fabricated from material that is hydrophilic and has an air entry pressure greater than the maximum matric suction to be applied during the test. Porous ceramic plates are typically usually used as porous plates. Porous plates are shown in the photographs in Figs. 4 and 5.

6.5.1 The porous plate shall be configured such that one side of the membrane is in contact with the specimen and is exposed to gaseous atmosphere in the pressure chamber. The other side

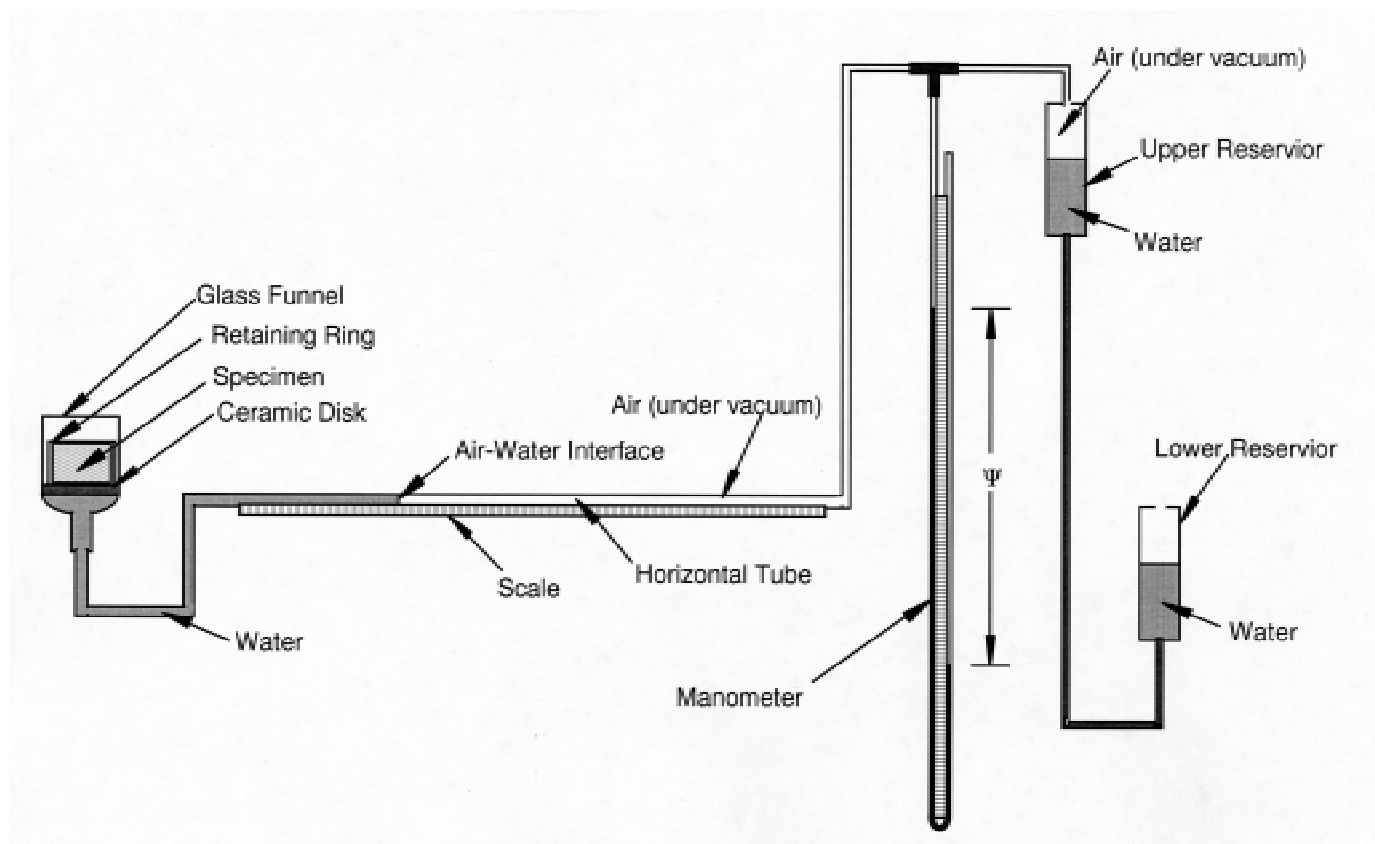

FIG. 1 Schematic of Hanging Column Apparatus

of the plate shall be in contact with the outflow system (Fig. 3). A seal shall be provided that prevents gas in the chamber from contacting the side of the porous membrane in contact with the outflow system. This seal shall also prevent water from leaking from the outflow system and into the pressure chamber.

6.6 *Pressure Membrane (Methods B and C)*—A porous membrane is used in a pressure extractor to provide a saturated interface between the pore water and the water in the measuring system. The porous membrane shall be fabricated from a material that is hydrophilic and has an air entry pressure higher than the maximum suction to be applied during the test. A non-corroding porous material having sufficient strength and stiffness shall be used to support the porous material (a stainless steel screen typically is used). The pores in the supporting material shall be sufficiently large to preclude development of measurable capillary stresses. The membrane and supporting material shall be configured such that the unsupported side of the membrane is in contact with the specimen and is exposed to gaseous atmosphere in the pressure chamber. The support side of the membrane shall be in contact with the outflow system. A seal shall be provided that prevents gas in the chamber from contacting the side of the porous membrane in contact with the outflow system. This seal shall also prevent water from leaking from the outflow system and into the pressure chamber.

6.7 *Capillary Tube (Methods A and B)*—A capillary tube is used to measure the outflow from the specimen for Methods A and B. The capillary tube shall be free of dirt, oil, or other

contaminants and include a scale that permits resolution of the volume expelled to 0.1 mL or better.

6.8 *Specimen Retaining Rings*—Specimens tested using Methods A, B, and C shall be retained on the porous plate or membrane using a retaining ring at least 5 mm in height and 25 mm in inside diameter. The wall thickness shall be sufficient to retain the soil without visible distortion. A photograph of a specimen in a typical retaining ring is shown in Fig. 6a. Retaining rings are typically constructed from stainless steel, acrylic, or polyvinyl chloride.

6.9 *Chilled Mirror Hygrometer (Method D)*—A chilled mirror hygrometer (also known as a chilled mirror psychrometer) shall be used to measure water activity to within 0.001. The chilled mirror hygrometer must be able to test specimens with a diameter of at least 20 mm and height of at least 5 mm. Water activity obtained from the chilled mirror hygrometer shall be converted to total suction using the Kelvin equation. A photograph of a chilled mirror hygrometer is shown in Fig. 7.

6.10 *Specimen Retaining Dish (Method D)*—Specimens tested using Method D shall be contained in a specimen retaining dish with a diameter of at least 20 mm and height of at least 5 mm. The dish shall be made of a non-porous and non-corroding material such as stainless steel or plastic. A photograph of a specimen in a retaining dish is shown in Fig. 6b.

6.11 *Moisture Content Container*—A container meeting the requirements outlined in Method D 2216 shall be provided for determination of water content.

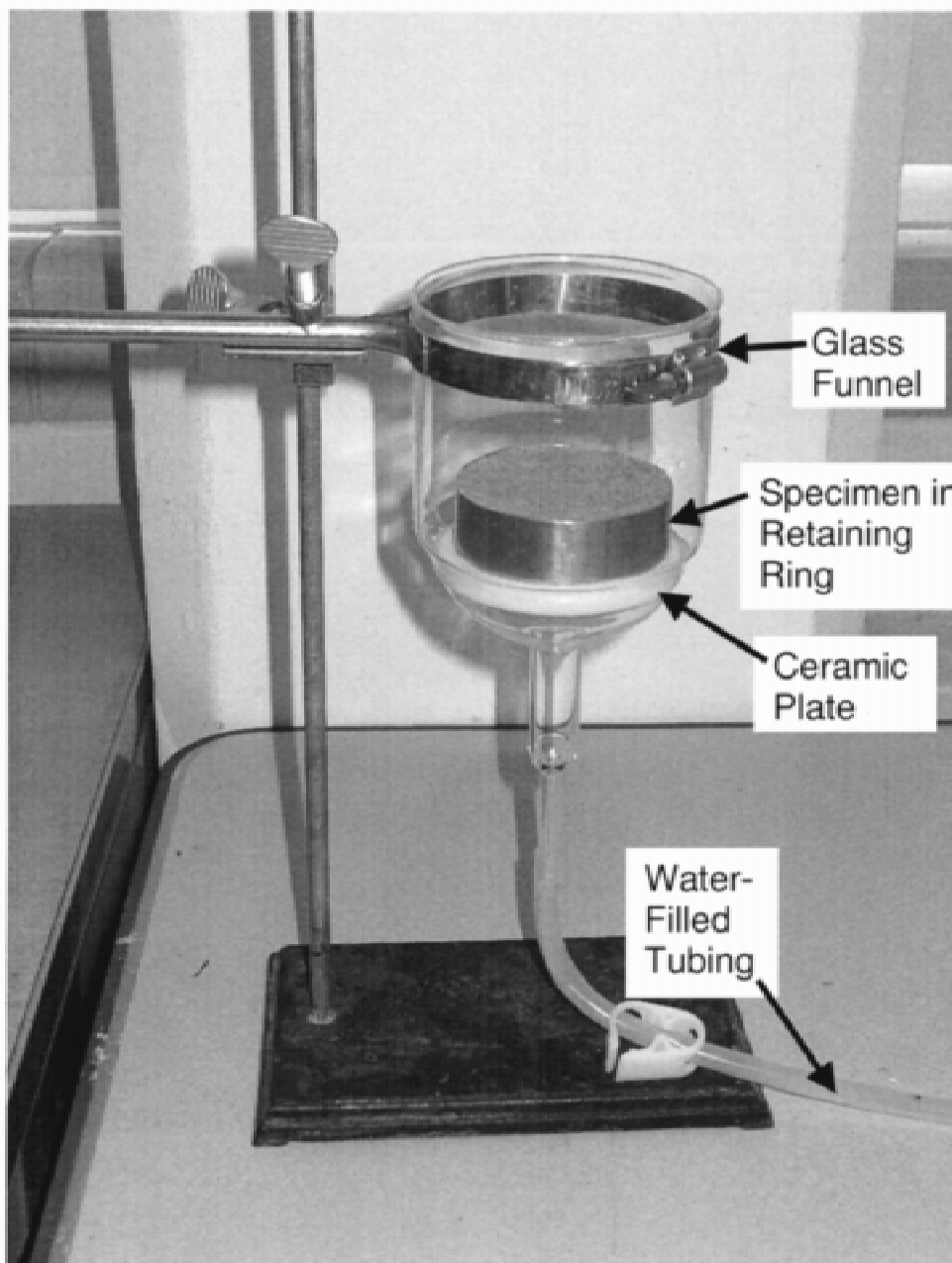

Specimen is contained in a retaining ring.

FIG. 2 Photograph of Funnel Used for Hanging Column Apparatus.

6.12 *Balance*—For Methods A-C, a balance shall be used that has a minimum capacity of 200 g and a sensitivity of 0.01 g. For Method D, a balance shall be used that has a minimum capacity of 50 g and a sensitivity of 0.001 g. All balances shall meet the requirements of Specification D 4753.

6.13 *Desiccator*—A desiccator shall be provided that has suitable size to hold specimens for cooling after removal from the oven. A desiccator is only recommended when moisture containers having close-fitting lids are not used (see Method D 2216).

6.14 *Drying Oven*—A thermostatically controlled drying oven capable of maintaining temperature at $110 \pm 5^\circ\text{C}$ as per requirements of Method D 2216.

6.15 *Temperature Controlled Centrifuge (Method E)*—A thermostatically controlled centrifuge capable of maintaining a temperature of $20 \pm 3^\circ\text{C}$ when operated between 0-10 000 RPM. A photograph of a centrifuge is shown in Fig. 8 with sealed sample support chamber and calibrated water collection tube. The centrifuge shall include a measurement device for recording outflow in the support chamber to the nearest 0.1 mL while the specimen is under centrifugation. A strobe light apparatus is normally used for this purpose.

6.16 *Specimen Support Chamber (Method E)*—A chamber used to retain the specimen and the calibrated cylinder used to collect the displaced water. A schematic of a specimen support chamber is shown in Fig. 9.

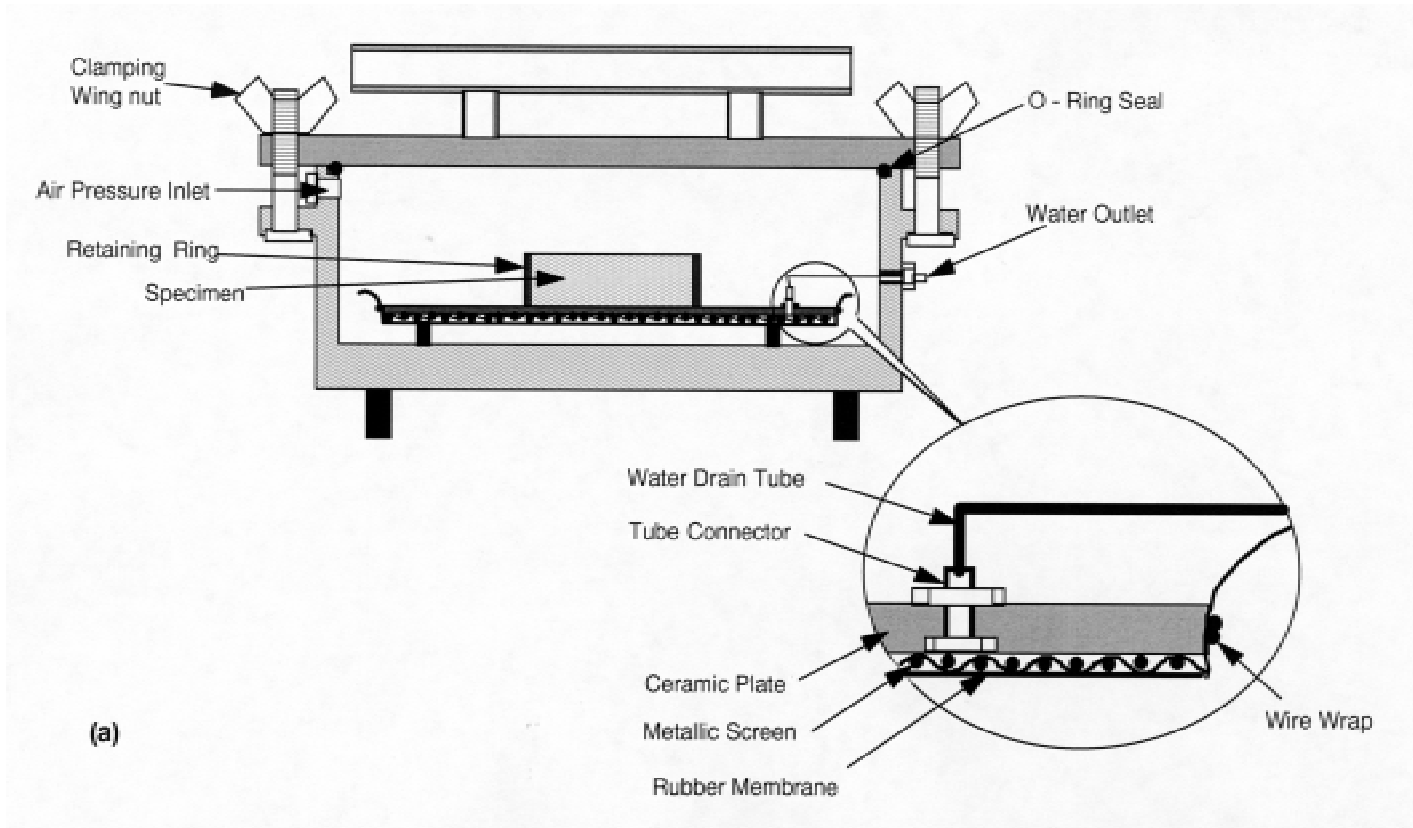

Schematic of pressure chambers with ceramic porous plates: (a) conventional chamber for single or multiple specimens and (b) chamber for single specimen

FIG. 3 Schematic of Pressure Chambers With Ceramic Porous Plates

6.17 *Saturation Tray, Chamber, or Apron (Methods A-E)*—Plates, membranes and specimens are saturated in a saturation tray, a saturation chamber, or directly in pressure chamber using a saturation apron. Trays shall have a depth greater than the sum of the specimen height and thickness of the porous plate (or membrane). Saturation chambers are vessels filled with water in which a specimen in a retaining ring can be inundated for saturation. A vacuum is applied to the water in a saturation chamber using an external device. A saturation apron in the pressure chamber may be used to impound water around a specimen for saturation. Aprons are only used for saturating specimens.

6.18 *Miscellaneous Tools*—wire saw, beveled straightedge, spatula, and other small tools for trimming test specimens, 10 mL and 100 mL graduated cylinders, 25 mL syringe.

6.19 *Laboratory Environment*—The laboratory temperature shall be maintained within $\pm 3^{\circ}\text{C}$ during the test. The apparatus shall be shielded from directly sunlight or other sources of heat that may cause variations in temperature. If very precise measurements are required, the hanging column or pressure chamber may be isolated in a thermally insulated box.

7. Reagents

7.1 Saturating Liquid:

7.1.1 The saturating liquid is used to saturate the porous plates and membranes, the specimen, and the outflow measuring components of the apparatus.

7.1.2 The saturating liquid should be specified by the requestor. If no specific type of saturating water is specified by

the requestor, the water shall be deaired 0.0025 M CaCl_2 solution or tap water. Distilled or deionized water shall not be used unless specified by the requestor. A biocide may be added to the water to minimize microbial growth during the test. If a biocide is added, the type and concentration of the biocide shall be included in the report.

7.1.3 *Deaired Water*—Deaired water shall be used. Water is usually deaired by boiling, spraying a fine mist of water into an evacuated vessel attached to a vacuum source, or by forceful agitation of water in a container attached to a vacuum source. To prevent dissolution of air back into the water, deaired water shall not be exposed to the atmosphere for prolonged periods.

8. Preparation

8.1 Preparation of Specimens:

8.1.1 *Specific Gravity*—Measure the specific gravity of solids on a sub-sample of the material to be tested following the method in Test Method D 854.

8.1.2 *Retaining Ring, Dish, or Mold*—Measure the inside diameter of the retaining ring, dish, or mold to the nearest 0.1 mm at three locations and record the average of these measurements as the diameter. Measure the height of the retaining ring, dish (inside height for dish), or mold to the nearest 0.1 mm at three locations and record the average of these measurements as the height. Weigh the retaining ring, dish, or mold and record its weight to the nearest 0.01 g (ring) or 0.001 g (dish).

8.1.3 *Specimens Prepared from Disturbed Samples*—Air dry and crush a representative sub-sample that has a mass at

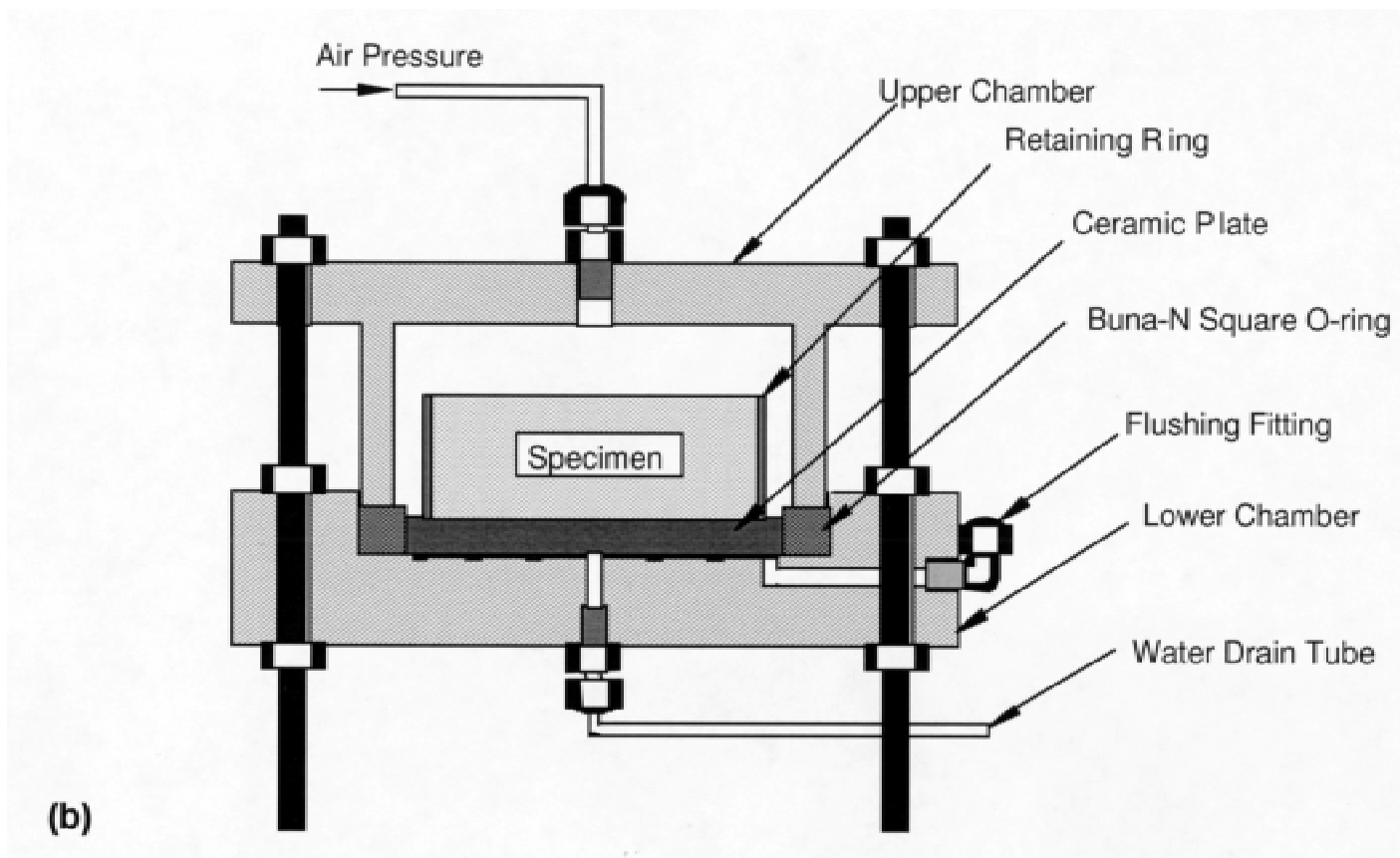

Schematic of pressure chambers with ceramic porous plates: (a) conventional chamber for single or multiple specimens and (b) chamber for single specimen

FIG. 3 Schematic of Pressure Chambers With Ceramic Porous Plates (continued)

least twice that required to fill the specimen retaining ring. The sample may be crushed following the procedure described in Practice D 421. Remove all particles from the crushed sub-sample having a diameter exceeding one-half the height of the retaining ring. If requested, moisten the sample to the gravimetric water content specified using tap water. Prepare a specimen by placing a known mass of the moistened sub-sample into the retaining ring (Methods A-D) or a specimen mold (Method E). Tap or compact the soil to the density specified by the requestor. Trim the upper surface of the specimen so that it is level with the top of the retaining ring or mold. Weigh the specimen in the retaining ring or mold and record the weight to the nearest 0.01 g. Measure the gravimetric water content of the remaining material using Method D 2216.

8.1.4 Specimens Prepared from Undisturbed Samples—For Methods A-D, place the undisturbed sample on the bench and gently place a retaining ring on the surface of soil. Use trimming tools to gently remove soil that protrudes beyond the edge of the retaining ring so that the ring can slide over the soil specimen with little effort. Continue trimming until the soil fills the retaining ring. Trim the top of the specimen flush with the top of the retaining ring. Weigh the specimen in the retaining ring and record the weight to the nearest 0.01 g. Measure the gravimetric water content of the remaining material using Method D 2216. This procedure is also used to prepare

specimens for testing in the chilled mirror hygrometer after being tested in the hanging column or pressure extractor.

8.1.4.1 A similar procedure is followed to prepare specimens for Method E, except no trimming ring or dish is employed. Specimens are trimmed from the undisturbed sample to form a right circular cylinder that fits inside the specimen support chamber. Typically specimens are 38 mm in diameter and 51 mm long (Fig. 9). When trimming is complete, measure the height of the specimen at three locations to the nearest 0.1 mm, and record the average of these measurements as the height. Similarly, measure the diameter of the specimen at three locations to the nearest 0.1 mm, and record the average of these measurements as the diameter. Weigh the specimen to the nearest 0.01 g. The sides of the trimmed specimen are wrapped in unsintered teflon tape. Stainless steel screens (220 mesh) are placed on the ends of the specimen.

8.1.5 Specimens Compacted in the Laboratory—Compact the specimen to the specified water content and density using the method of compaction specified by the requestor. For Methods A-D, place the compacted specimen on the bench and gently place a retaining ring on the surface of soil. Use trimming tools to gently remove soil that protrudes beyond the edge of the retaining ring so that the ring can slide over the soil specimen with little effort. Continue trimming until the soil fills the retaining ring. Trim the top of the specimen flush with the top of the retaining ring. Weigh the specimen in the retaining

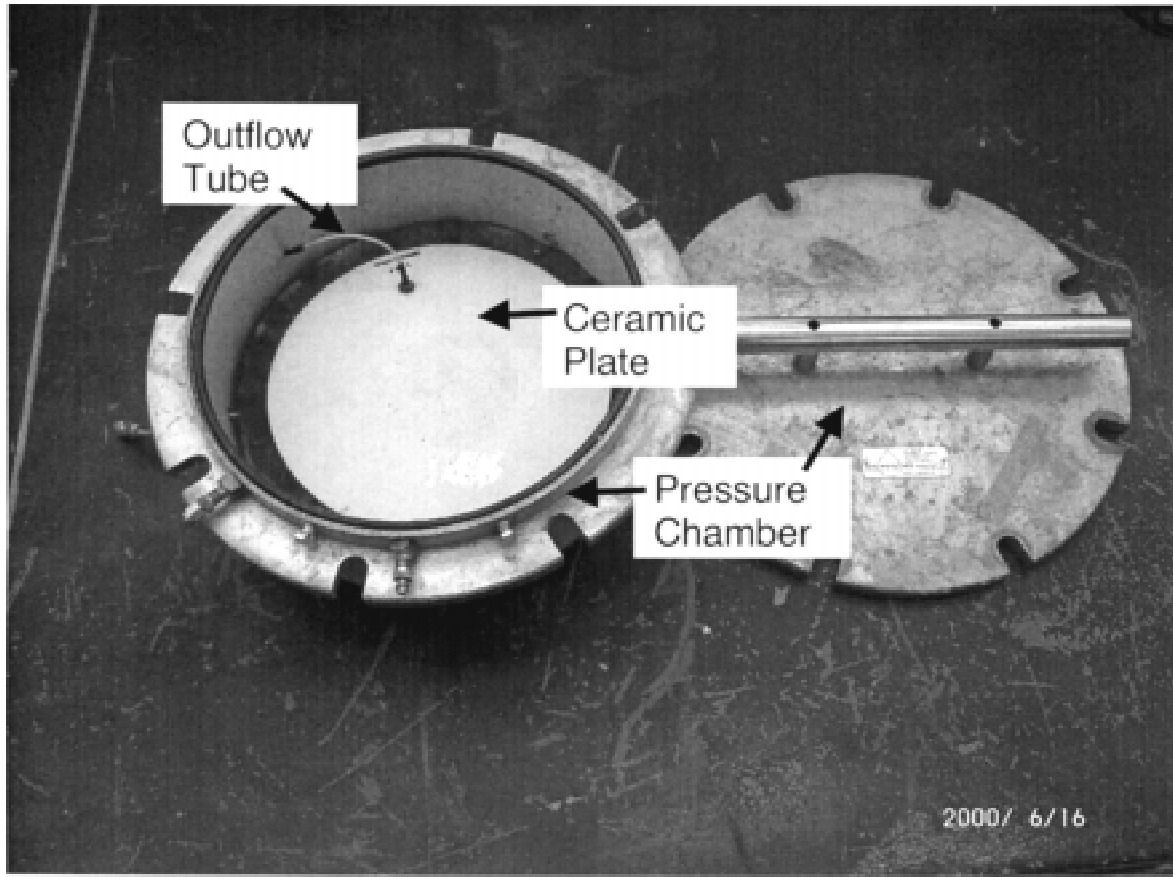

FIG. 4 Photographs of a Multiple-Specimen Pressure Chamber

ring and record the weight to the nearest 0.01 g. Measure the gravimetric water content of the remaining material using Method D 2216.

8.1.5.1 A similar procedure is followed to prepare specimens for Method E, except no trimming ring or dish is employed. Specimens are trimmed from the compacted soil to form a right circular cylinder that fits inside the specimen support chamber. Typically specimens are 38 mm in diameter and 51 mm long (Fig. 9). When trimming is complete, measure the height of the specimen at three locations to the nearest 0.1 mm, and record the average of these measurements as the height. Similarly, measure the diameter of the specimen at three locations to the nearest 0.1 mm, and record the average of these measurements as the diameter. Weigh the specimen to the nearest 0.01 g. The sides of the trimmed specimen are wrapped in unsintered teflon tape. Stainless steel screens (220 mesh) are placed on the ends of the specimen.

8.2 Saturation of Funnel, Porous Plate, or Membrane:

8.2.1 *Hanging Column (Method A)*—Immerse the funnel containing the porous plate in a saturation chamber filled with deaerated water under a vacuum of at least 75 kPa (Fig. 10). The funnel shall be immersed for at least 24 h and until no air bubbles are visible.

8.2.2 *Porous Plates (Methods B and C)*—Porous plates shall be submerged in a tray of deaired water or in a saturation chamber under vacuum for a period of at least 24 h and until no gas bubbles are visible. If a saturation chamber is used, the

ceramic plates shall initially be soaked for 1 h in a saturation tray and then transferred to the saturation chamber. During saturation, a vacuum of at least 75 kPa shall be applied to the chamber for 24 h. At the end of the 24 h period, the vacuum shall be removed and re-applied, and the specimen inspected for escaping gas bubbles for 1 h. Repeat this procedure until no air bubbles are observed for at least two consecutive applications of vacuum.

8.2.3 *Porous Membrane (Methods B and C)*—Porous membranes are delicate and must be handled with care to prevent damage. A new membrane shall be used for each test. Before handling, porous membranes shall be carefully placed in a pan of warm water for at least 30 min to permit softening. The softening water shall be the same water used for saturation. After softening, saturate the porous membrane by submerging in a tray of deaired water for at least 24 h and until no gas bubbles are visible.

8.3 Saturation of Specimen (Methods A-E):

8.3.1 Specimens shall be saturated by inundation in a saturation tray, a saturation chamber, or directly in the hanging column or pressure chamber. The specimen should be maintained within the retaining ring during saturation to prevent distortion or sloughing. Specimens that are sufficiently cohesive can be placed in the saturation tray on top of a porous material (perforated plastic, wire screen, or non-woven geotextile) without the accompanying ceramic plate. Non-cohesive specimens generally need to be saturated while in contact with

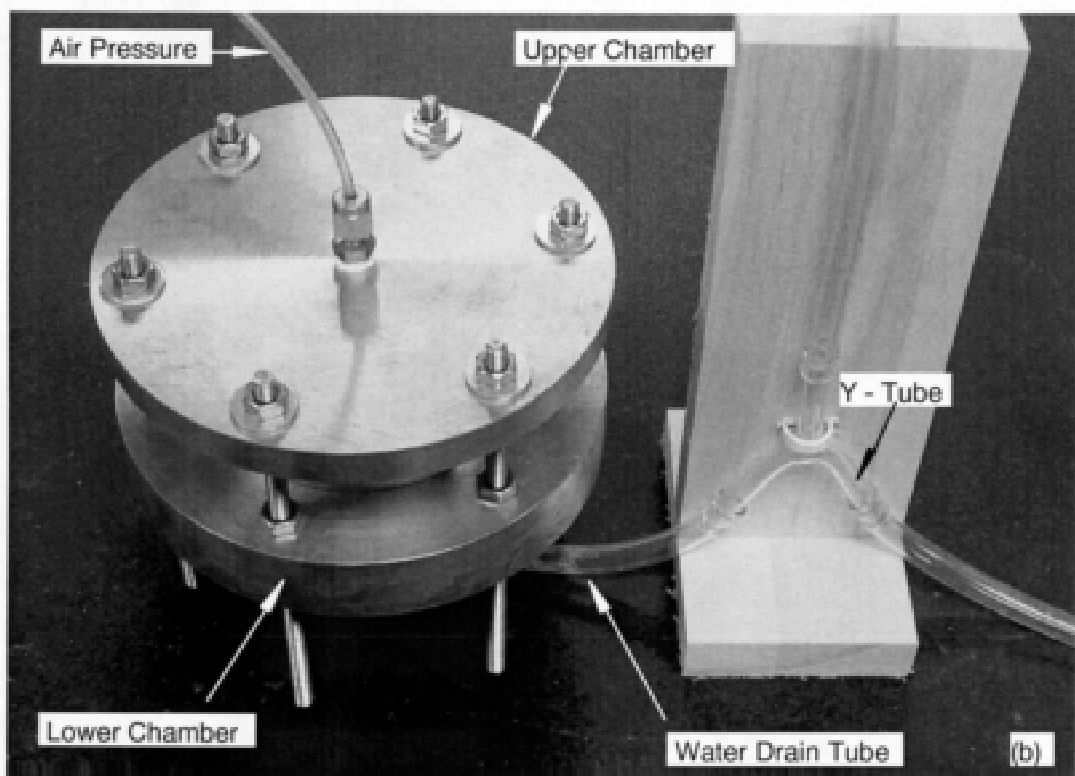
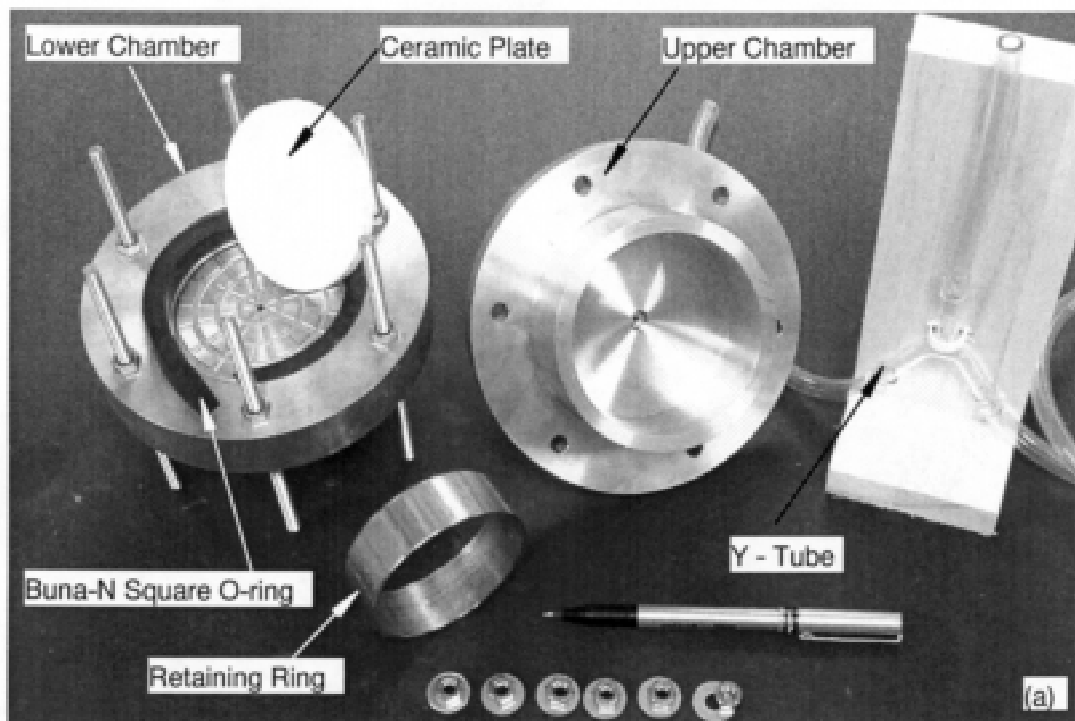
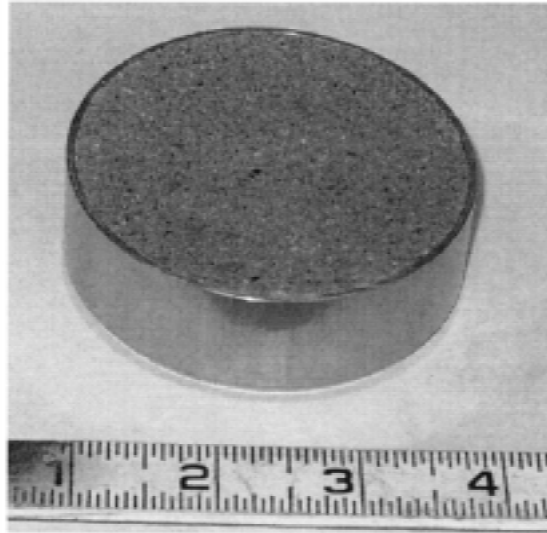

FIG. 5 Photographs of a Single-Specimen Pressure Chamber and Associated Equipment: (a) Open and (b) Assembled

a ceramic plate so that the specimen does not become dislodged from the retaining ring. Saturation shall continue for at least 24 h and until no gas bubbles are visible. When the ceramic plate is included during saturation of the specimen, the plate shall be saturated beforehand using the procedure in 8.2.

8.3.2 During saturation in a saturation chamber, apply a vacuum to the chamber of at least 75 kPa for 24 h. At the end of the 24 h period, remove and reapply the vacuum, and then inspect the specimen for 1 h for escaping gas bubbles. Repeat this procedure until no air bubbles are observed for at least two



(a)



(b)

FIG. 6 Specimen in Retaining Ring (Methods A-C) (a) and Retaining Dish (Method D) (b)

consecutive applications of vacuum. Specimens saturated in a saturation chamber generally are sandwiched between two porous stones and two perforated plastic plates (Fig. 11). The plates are clamped together using bolts.

8.3.3 After saturation in a saturation tray or chamber, weigh the specimen and compute the degree of saturation. Ensure that the degree of saturation is $100 \pm 3\%$. If the saturation is less than 97%, repeat the saturation procedure.

8.4 *Check of Porous Plate:*

8.4.1 When first used and every ten uses thereafter, the porous ceramic plate shall be tested to confirm that the air entry

pressure is adequate and to check for clogging. Saturate the porous plate using the procedure in 8.2. Install the porous plate in the hanging column or pressure chamber using the methods in Section 9. Elevate the suction in the hanging column or the pressure extractor in increments equal to one-tenth the reported air entry pressure of the plate or the maximum suction to be applied using the apparatus, whichever is lower. Maintain each suction for at least 30 min, and record the total outflow at the end of each 30 min period. Graph the total outflow collected during each increment in suction vs. the total suction applied. Beyond initial expulsion of free water (Fig. 12), the volume of

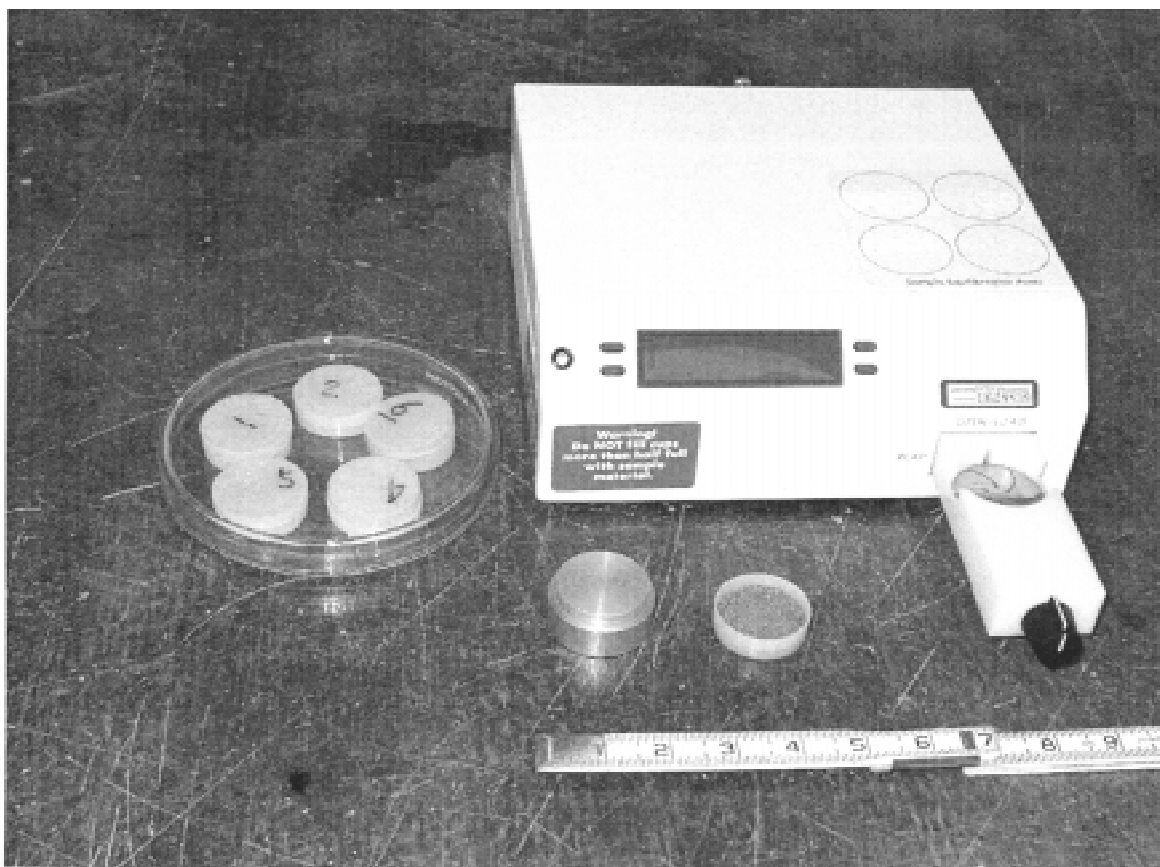

FIG. 7 Photograph of a Chilled Mirror Hygrometer With Open Sample Drawer and Specimen to be Inserted for Testing

water expelled shall not exceed 0.4 mL. If the volume expelled is larger than 0.4 mL or a slope or break point in the graph exists, discard the plate.

8.4.2 Measure the saturated hydraulic conductivity of the saturated ceramic plate using the method in Test Methods D 5084. If the saturated hydraulic conductivity has decreased more than a factor of five relative to the saturated hydraulic conductivity when new, cleanse the plate or discard the plate. After cleansing, re-check the hydraulic conductivity and the air entry pressure using the aforementioned procedure.

9. Procedure

9.1 Hanging Column (Method A):

9.1.1 *Set-up Apparatus*—Use clear flexible plastic tubing to connect the saturated funnel to the capillary tube (Fig. 1). Use clear flexible plastic tubing to connect the other end of the capillary tube to the reservoir apparatus that applies the suction. Fill the funnel, the tubing connecting the funnel to the capillary tube, and a portion of the capillary tube with the same de-aired water solution used for saturating the specimen. Remove all air-bubbles from all portions of the apparatus filled with water.

9.1.2 *Set Reservoir and Funnel Elevation*—Adjust the relative elevation of the reservoirs so that the elevation difference on the manometer is zero (Fig. 1). Adjust the elevation of the funnel so the top of the porous plate in the funnel is at the same elevation as the centerline of the capillary tube. Remove all excess water above the porous plate using a syringe.

9.1.3 *Insert and Equilibrate Specimen*—Place the specimen contained in the retaining ring on the porous plate. Twist the specimen approximately 45° to ensure good contact between the specimen and the porous plate. If contact is a concern, place a section of rigid screen or geonet on the upper surface of the specimen, and then apply a weight on top of the screen to provide a surcharge. A 1 kg weight typically is used. Secure a thin sheet of plastic film over the top of the funnel to prevent evaporation. Place a small hole in the plastic (for example, with a pin) to ensure equilibrium of air pressure. Allow the specimen to equilibrate for at least 48 h, and until movement of the air-water interface ceases. Record the position of the air-water interface in the capillary tube at the end of the equilibrium period.

9.1.4 *Suction Application*—After equilibration, apply the first increment of suction by adjusting the elevation of the water reservoirs (Fig. 1) until the manometer shows the desired suction has been applied. The first increment in suction should be no more than one-half the anticipated air-entry suction. Monitor the location of the air-water interface regularly until movement of the air-water interface has ceased for at least 24 h. Record the final location of the air-water interface. Then apply the next increment in suction using the same procedure.

NOTE 2—The increments of suction that should be applied depend on the pore size distribution of the specimen and the level of detail desired for the soil water characteristic curve. A common set of increments is 0, 5, 20, 40, 100, 200, 400, 600, 1000, 1500, 2000, and 4000 mm of water.



FIG. 8 Photograph of a Temperature-Controlled Centrifuge With Various Specimen Support Chambers

9.2 Pressure Chamber with Volumetric Measurements (Method B):

9.2.1 *Number of Specimens*—Tests using Method B are normally conducted on a single specimen. Multiple specimens

may be tested in a single pressure chamber only if a separate porous plate or membrane is used for each specimen, the plates (or membranes) are not in contact, and a separate outflow tube is provided for each plate.

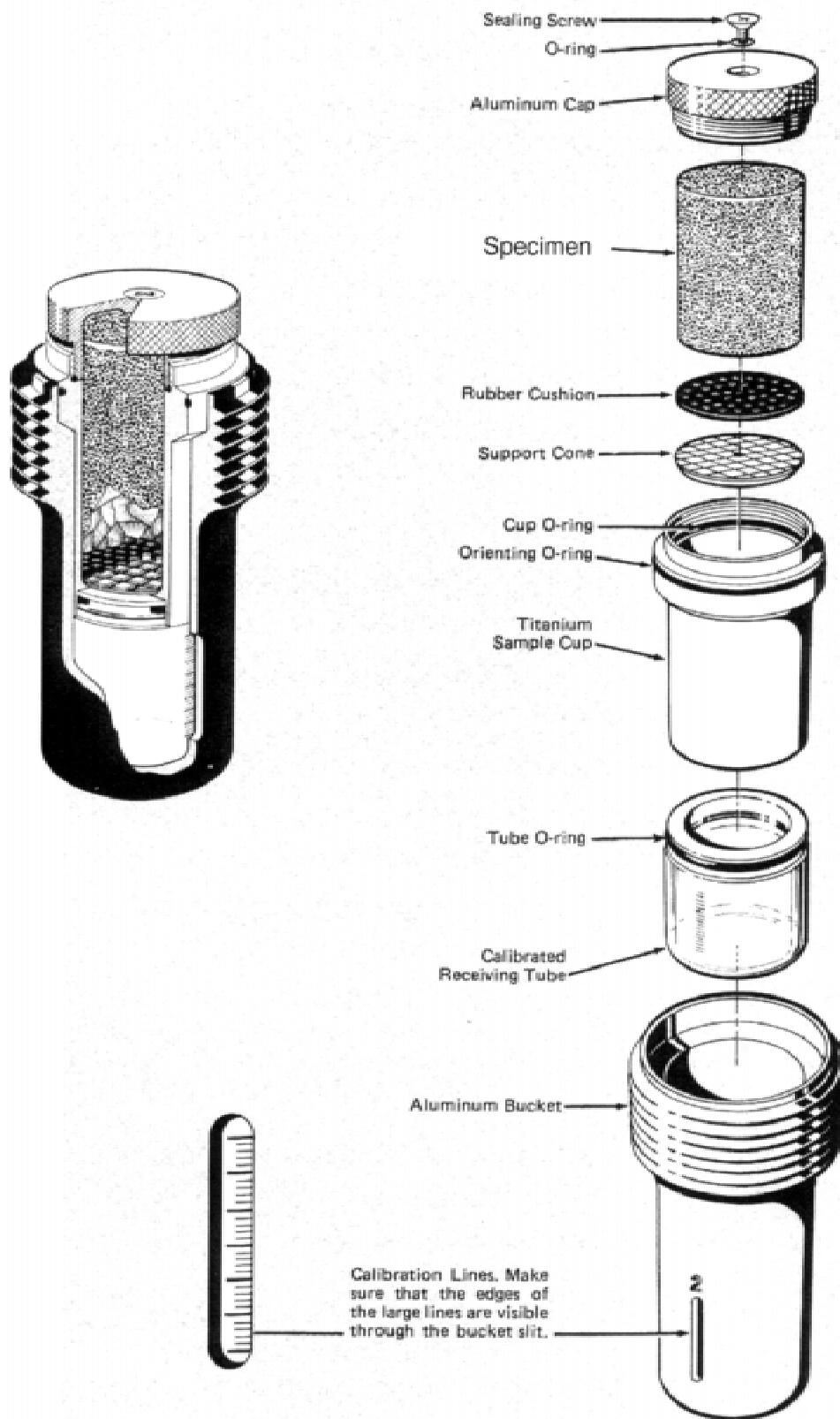

FIG. 9 Schematic of a Specimen Support Chamber

9.2.2 *Set-up Apparatus*—Place a saturated porous plate (or membrane) in a pressure chamber (Fig. 3) and attach the

outflow tube to the porous plate (or membrane). Use clear flexible plastic tubing to connect the outflow tube to the

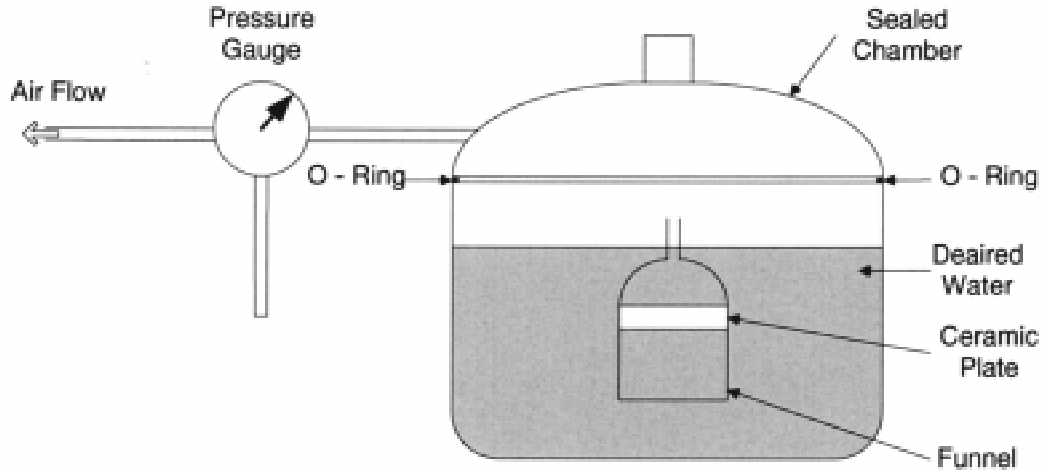

FIG. 10 Schematic of a Saturation Chamber for Saturating Plates and Specimens

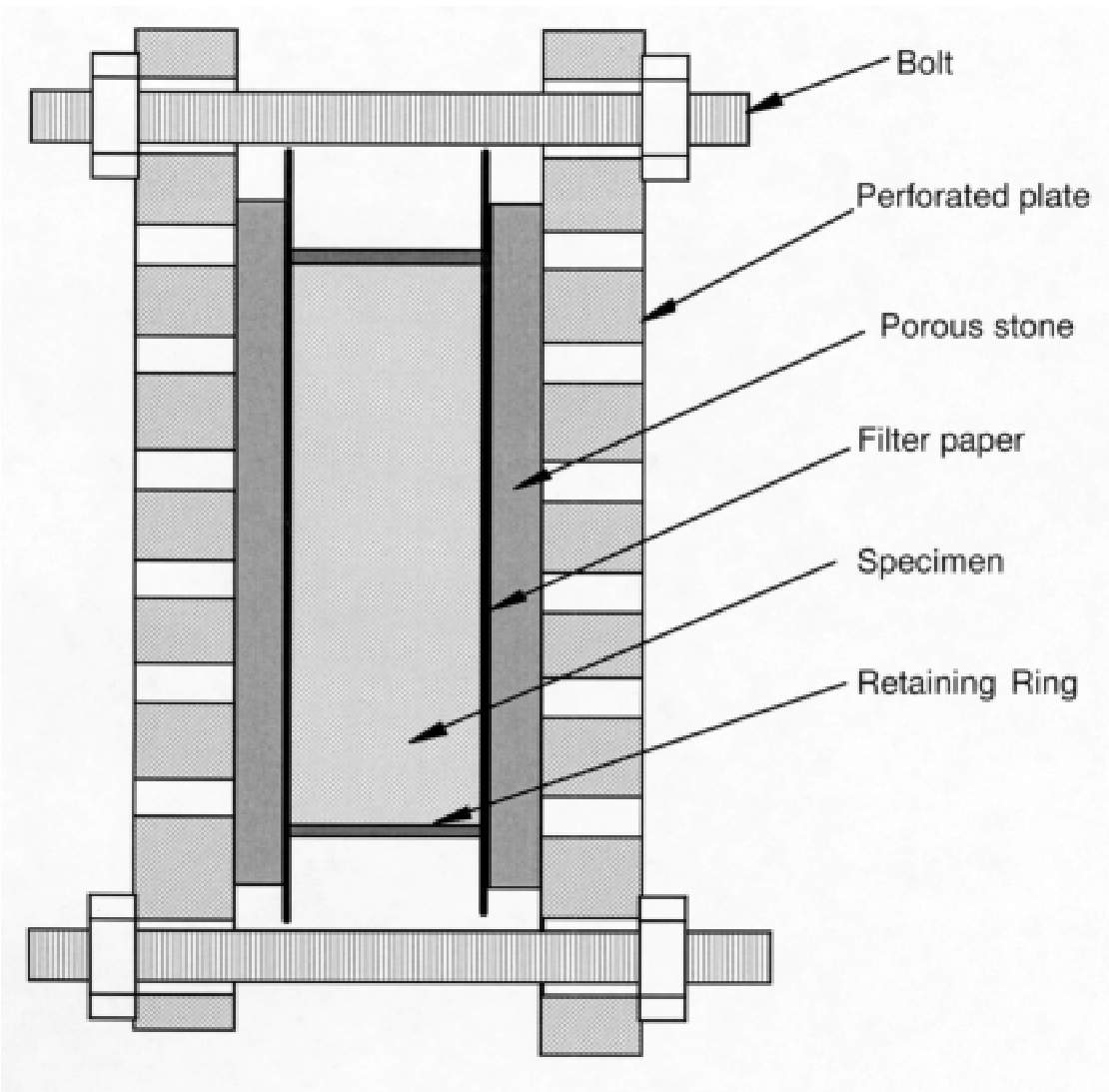

FIG. 11 Assembly Used to Contain Specimens When Saturating in a Saturation Chamber

capillary tube as shown in Fig. 13. Saturate the outflow tubing, all connections between the outflow tubing and the porous

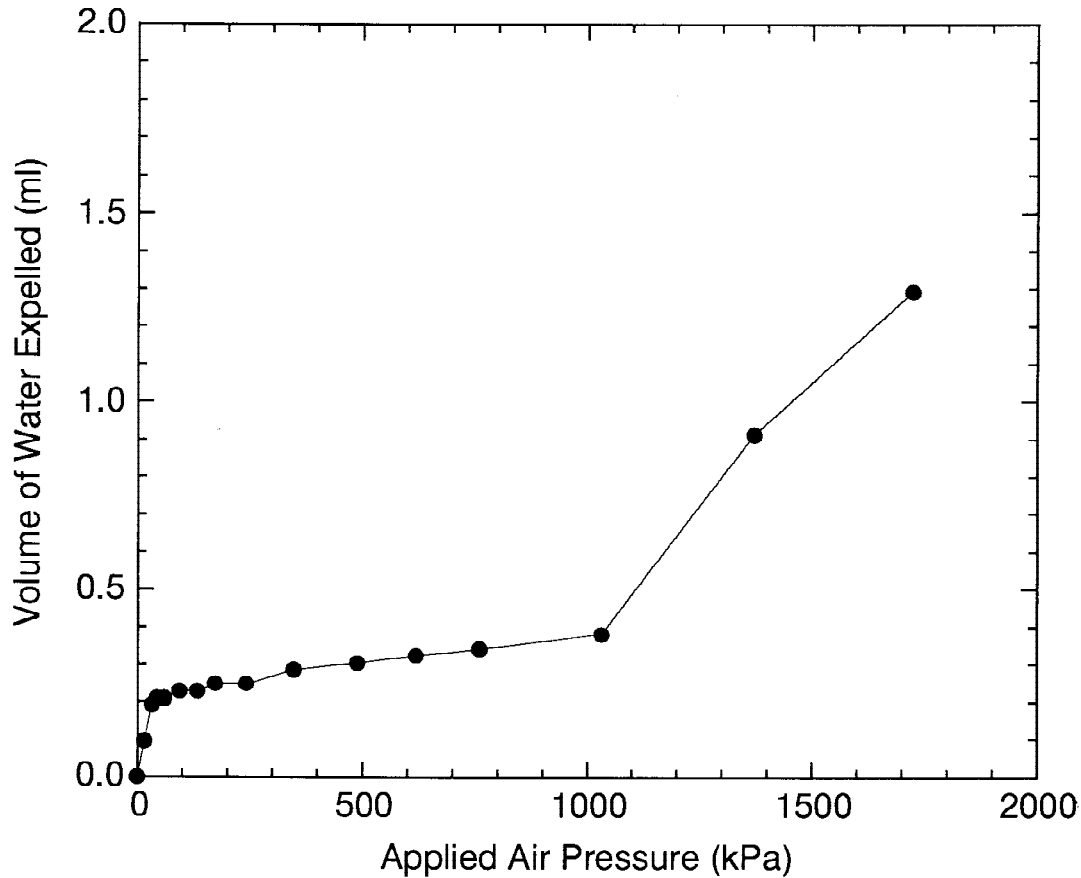

Plate function satisfactorily until a gas pressure exceeding 1000 kPa was applied, after the volume of water expelled increased dramatically. The plate was discarded.
FIG. 12 Outflow from Check of a Ceramic Plate With a Reported Air Entry Pressure of 1500 kPa

plate (or membrane), and the flexible tubing connected to the capillary tube with the same de-aired water solution used for saturating the specimen. Remove all air-bubbles from the portions of the apparatus filled with water. Adjust the elevation of the pressure plate (or membrane) so the top of the porous plate is at the same elevation as the centerline of the capillary tube. Remove all excess water above the porous plate using a syringe. Mark the location of the water level in the vent (Y-) tube (Fig. 10). The water level in the vent tube should be at the elevation of the capillary tube and the surface of the porous plate. If the water level is not at this elevation, inspect the system for leaks.

9.2.3 Insert and Equilibrate Specimen—Place the specimen contained in the retaining ring on the porous plate (or membrane). Twist the specimen approximately 45° to ensure good contact between the specimen and the porous plate. If contact is a concern, place a section of rigid screen or geonet on the upper surface of the specimen, and then apply a weight on top of the screen to provide to a surcharge. A 1 kg weight typically is used. Close and seal the pressure chamber. Allow the specimen to equilibrate for at least 48 h, and until movement of the air-water interface in the capillary tube ceases. Record the position of the air-water interface in the capillary tube at the end of the equilibrium period.

9.2.4 Suction Application—After equilibration, apply the first increment of suction by adjusting the pressure regulators until the desired suction has been applied. The first increment in suction should be no more than one-half the anticipated air-entry suction. Monitor the location of the air-water interface regularly until movement of the air-water interface has ceased for at least 24 h. Record the final location of the air-water interface.

9.2.4.1 After equilibrium has been established, apply the next increment in suction using the same procedure and monitor movement of the air-water interface in the capillary tube until movement of the air-water interface has ceased and equilibrium has been established. For suctions less than 500 kPa, equilibrium is established when the air-water interface has not moved for at least 24 h. For suctions between 500 to 1000 kPa, equilibrium is established when the air-water interface has not moved for at least 48 h. For suctions greater than 1000 kPa, equilibrium is established when the air-water interface has not moved for at least 96 h.

NOTE 3—Regularly inspect the outflow tubing for air bubbles caused by diffusion of air through the porous plate or membrane. Gently tap the tube so that the bubbles flow to the vent tube where they can be expelled (Fig. 13).

NOTE 4—Suctions of 10, 50, 100, 300, 500, 1000, and 1500 kPa are

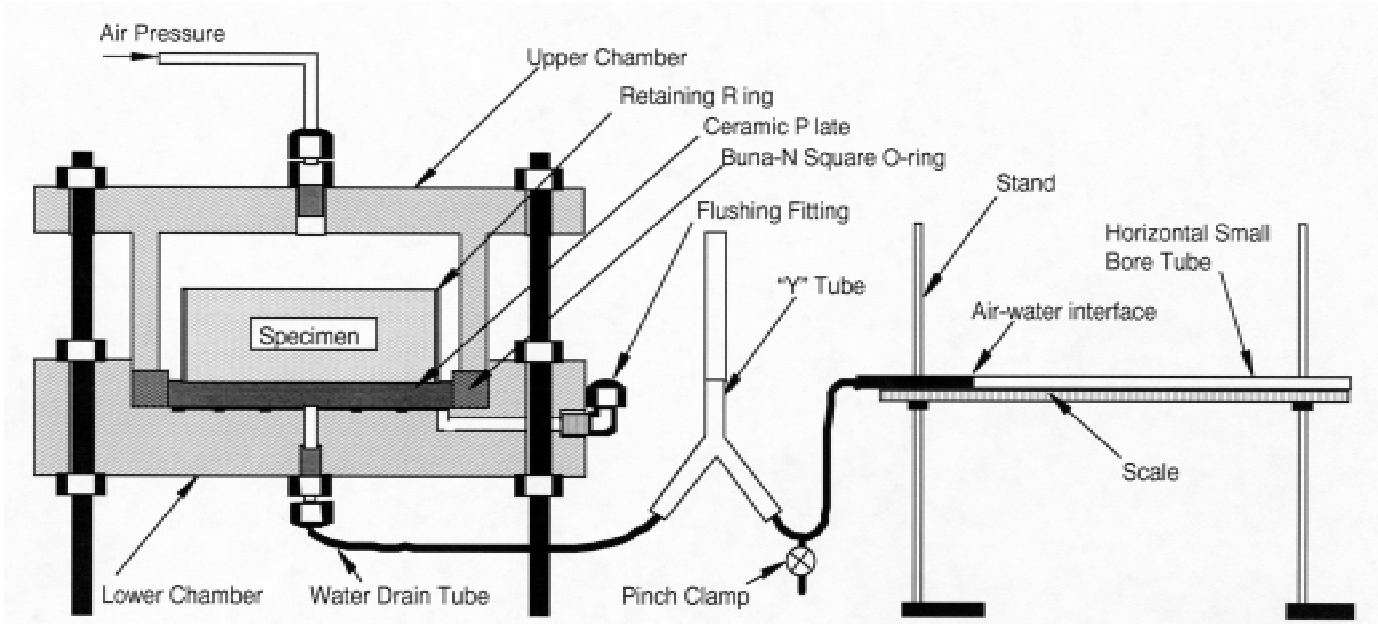

FIG. 13 Schematic of a Pressure Extractor With Ceramic Porous Plate and Capillary Tube for Measuring Outflow as Used in Method B

often used to define the soil water characteristic curve using Methods B and C.

NOTE 5—At high suctions (> 1000 kPa), very small volumes of water may be expelled, especially from coarser soils. These volumes may be difficult to measure, and ensuring that equilibrium has been established can be difficult. Accuracy of the dry end of the soil water characteristic curve (that is, suctions exceeding 1000 kPa) can be checked by conducting additional tests using Method D. If the dry end of the soil water characteristic curve differs substantially when measured with Methods B (or C) and D, the data from Method D should be used to define the dry end of the soil water characteristic curve.

9.3 Pressure Chamber with Gravimetric Measurements (Method C):

9.3.1 *Duplicates*—For Method C, duplicate tests should be performed when practical on specimens that are as close to identical as possible. Duplicate specimens shall be placed in retaining rings on opposite sides of the porous plate (or membrane). Specimens may not be in contact during the testing procedure.

9.3.2 *Multiple Specimens*—Only soils of similar texture may be tested together in one chamber. The time required to reach equilibrium varies greatly with soil texture due to differences in pore size distribution. Consequently, soils of dissimilar texture should not be tested at the same time. When multiple specimens are tested, contact between the specimens shall be prevented.

9.3.3 *Set-up Apparatus*—Place a saturated porous plate (or membrane) in a pressure chamber (Fig. 3a) and attach the outflow tube to the porous plate (or membrane). Direct the outflow tube to a graduated cylinder or similar device that can measure volume with an accuracy of 0.1 mL or better. Saturate the outflow tubing and all connections between the outflow tubing and the porous plate (or membrane) with the same de-aired water solution used for saturating the specimen. Remove all air-bubbles from those portions of the apparatus filled with water. If more than one plate (or membrane) is used

in a chamber, the porous plate (or membrane) shall not touch any specimen except the specimens intended to be in contact with the plate. No contact may exist between the plates.

9.3.4 *Insert and Equilibrate Specimens*—Place the specimens on the porous plate (or membrane). Twist each specimen approximately 45° to ensure good contact between the specimen and the porous plate. Close the pressure chamber. Allow the specimen to equilibrate for at least 48 h. Record the volume of water in the graduated cylinder used to collect outflow at the end of the 48 h period.

NOTE 6—When testing soils using Method C that contain coarse fragments, or soils that may present difficulties in obtaining intimate hydraulic contact between the soil and the porous plate (or membrane), a 6-mm-thick layer of fine silica sand (that is, silica sand passing the No. 200 sieve) may be placed on the surface of the porous plate or membrane to ensure good hydraulic contact. When silica sand is used, a sheet of fine filter paper shall be placed between the soil and the silica sand to prevent penetration of sand into the soil specimen. This contact layer shall not be used in Method B. When contact is a concern for fine soils, the specimen may be surcharged using a weight (1 kg weight is typical). A section of rigid screen or geonet shall be placed between the upper surface of the specimen and the weight to ensure free access of air.

NOTE 7—Specimens tested using Method C are sometimes saturated in the pressure chamber. Saturation in the pressure chamber is generally by soaking in a pool of water that inundates the specimen. The elevation of the pool is increased gradually from an initial depth of approximately 3 mm (± 1 mm) in 3-mm increments over a period of several hours until the water just covers the specimen. Saturation is assumed to be complete after the specimen has been inundated for 24 h. If the specimen is saturated in the chamber, all excess water on the plate (or membrane) must be removed (for example, using a syringe) before the chamber is closed and the test is initiated.

9.3.5 *Suction Application*—After equilibration, apply the first increment of suction by adjusting the pressure regulators until the desired suction (gas pressure) has been applied. The first increment in suction should be no more than one-half the anticipated air-entry suction. Record the volume of outflow in

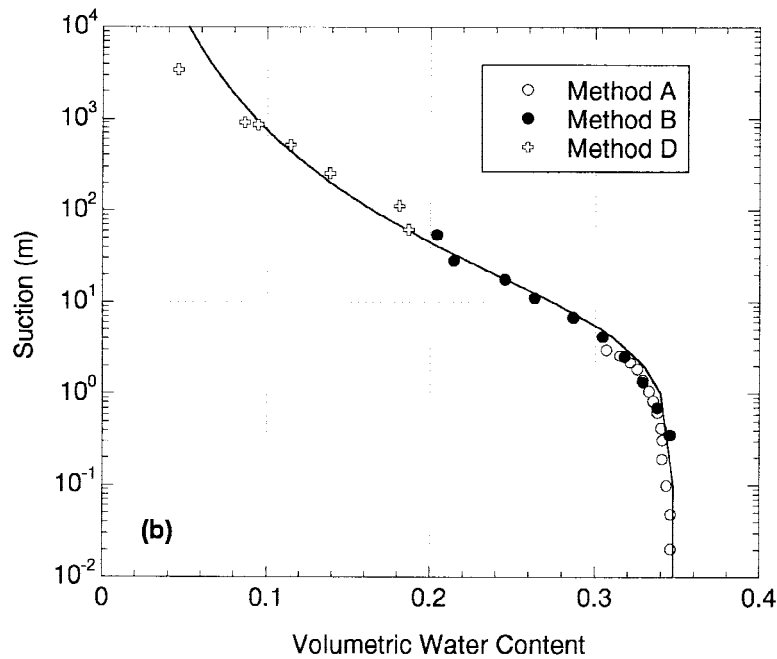
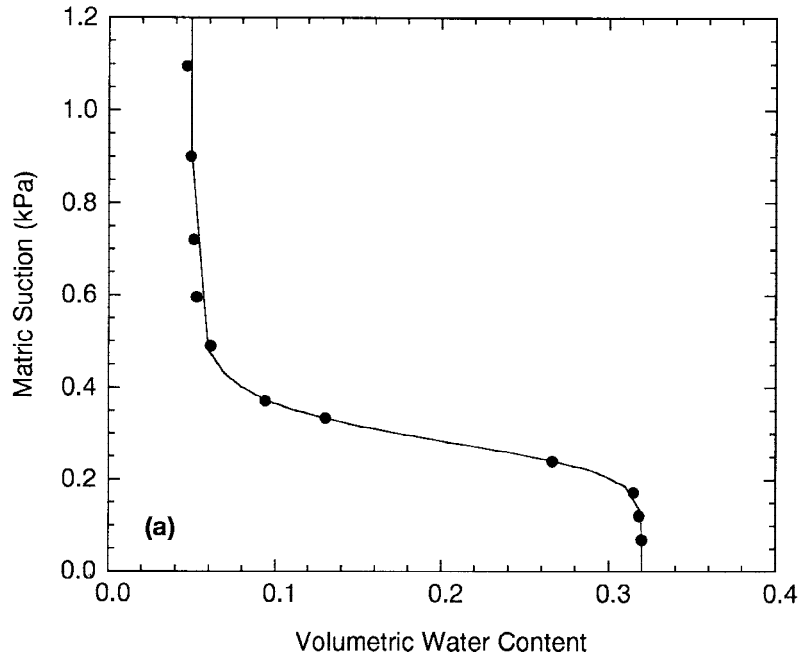

Soil water characteristic curves for (a) a clean medium sand obtained using Method A, (b) a sandy clay using a combination of Methods A, B, and D for low, moderate, and high suctions, and (c) a sandy silt obtained using Method C. All suctions reported in m of water.

FIG. 14 Soil Water Characteristic Curves

the graduated cylinder regularly until water has not been expelled for at least 24 h.

9.3.5.1 After equilibrium has been established, clamp the outflow tube to prevent backflow, exhaust the pressure, and open the pressure chamber. Quickly remove the specimens and their retaining rings from the porous plate (or membrane) using a wide-blade spatula. Immediately weigh the specimens. If the same specimens are to be used throughout the test, place the

specimens back on the porous plate (or membrane) and twist each specimen approximately 45° to ensure good contact. Alternatively, a new specimen may be used for each increment provided that that all specimens used to define a soil water characteristic curve are practically identical. Close and seal the pressure chamber, remove the clamp on the outflow tube, and quickly raise the gas pressure to the next suction. Monitor the outflow volume until outflow has ceased for at least 24 h.

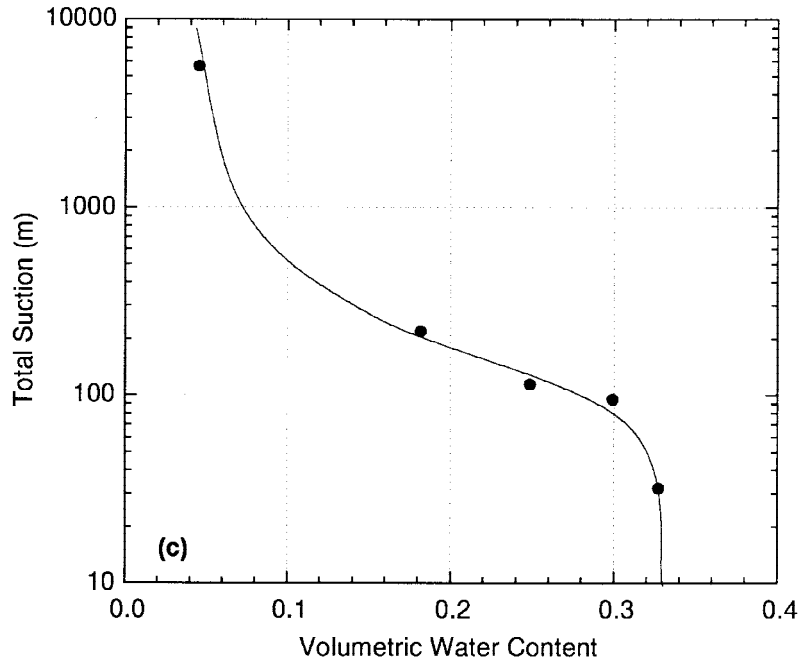

Soil water characteristic curves for (a) a clean medium sand obtained using Method A, (b) a sandy clay using a combination of Methods A, B, and D for low, moderate, and high suctions, and (c) a sandy silt obtained using Method C. All suctions reported in m of water.

FIG. 14 Soil Water Characteristic Curves (continued)

Repeat this procedure until all suctions specified by the requestor have been determined. When suctions between 500 to 1000 kPa are being established, monitor the outflow volume until the outflow has ceased for 48 h. For suctions greater than 1000 kPa, monitor the outflow volume until outflow has ceased for 96 h. If concern exists regarding equilibrium at high suctions, check this portion of the soil water characteristic curve using the procedure described in Note 5.

NOTE 8—Re-establishing hydraulic contact between the soil specimen and the plate (or membrane) can be difficult after suction has been applied. If concern exists regarding hydraulic contact, separate specimens may be used for each increment. These specimens should be prepared so that they are as identical as possible. If separate specimens are used, the gravimetric water content of each specimen should be determined after testing using the method in Method D 2216.

9.4 Chilled Mirror Hygrometer (Method D):

9.4.1 Procedure—Place the soil specimen in a retaining dish and insert the dish into the chilled mirror hygrometer (Fig. 7). Measure the water activity to an accuracy of 0.001 using the hygrometer. Record the water activity.

9.4.1.1 If the soil water characteristic curve is to be determined using a series of specimens prepared at different volumetric water contents, measure the water activity of each specimen using the hygrometer. Then weigh each specimen to the nearest 0.001 g and determine the gravimetric water of each specimen using Method D 2216.

9.4.1.2 If a single specimen is to be used, measure the water activity at the first water content and then allow the specimen to dry by exposure to the atmosphere until the next water content is achieved. Monitor the change in water content by periodically measuring the weight of the specimen and dish to the nearest 0.01 g. After the specimen has dried to the next

water content, record the weight of the dish and specimen to the nearest 0.001 g, seal the dish, and allow the specimen to equilibrate for 24 h. After equilibration, measure the water activity using the hygrometer as described in 9.4.1. Repeat this procedure until the water activity has been measured at each water content specified by the requestor. After the final measurement of water activity has been made, measure the final gravimetric water content of the specimen using the method in Method D 2216.

9.5 Centrifuge (Method E):

9.5.1 Procedure—Place the specimen in the support chamber and seal the chamber (Fig. 9). Record the distance from the center of the axis of rotation to the bottom of the specimen (outer radius of rotation) to the nearest 0.1 mm. Record the distance from the center of the axis of rotation to the top of the specimen (inner radius of rotation) to the nearest 0.1 mm. Install the support chamber in the centrifuge, and begin centrifugation at an angular velocity corresponding to the lowest suction to be induced (see 10.4). Centrifuge for at least 120 min, and periodically record the volume of water displaced through centrifugation to the nearest 0.1 mL. Continue centrifugation until no additional water is displaced, and record the total volume of water displaced to the nearest 0.1 mL. Repeat the procedure at incrementally higher angular velocities to define the soil water characteristic curve.

NOTE 9—Angular velocities of 100, 200, 400, 800 and 1500 RPM are often used to define the soil water characteristic curve using Method E.

10. Calculations

10.1 Saturated Volumetric Content—The water content at zero matric suction is assumed to be the saturated water

content. Compute the saturated gravimetric and volumetric water contents using the following methods if the test was conducted using Methods A-E. Saturated specimens are not tested with Method D.

10.1.1 For specimens saturated using a saturation tray or a saturation chamber and then tested using Methods A, B, or E, calculate the saturated gravimetric and volumetric water contents using the dry density recorded after preparation of the specimen, the gravimetric water content at saturation, and the volume of water imbibed or expelled during the saturation phase. The saturated gravimetric water content is computed as:

$$w_{sat} = \frac{M_{sat}(1 + w_m)}{M_m} - 1 \quad (1)$$

where M_m and w_m are the mass and gravimetric water content of the moist soil in the retaining ring after the specimen has been prepared (trimmed or compacted in ring), M_{sat} is the mass of soil in the retaining ring after saturation. The dry density is computed as:

$$\rho_d = \frac{M_m}{V(1 + w_m)} \quad (2)$$

where V is the volume of the retaining ring (Methods A and B). For Method E, V is the volume of the specimen and is computed as:

$$V = \frac{\pi d^2 L}{4} \quad (3)$$

where d is the diameter of the specimen and L is the height of the specimen, as described in 8.1. The saturated volumetric water content is computed as:

$$\theta_{sat} = \frac{\rho_d}{\rho_w} w_{sat} \quad (4)$$

where ρ_w is the density of water.

10.1.2 For specimens saturated directly in a pressure extractor using a saturating apron, compute the saturated volumetric and gravimetric water contents as:

$$\theta_{sat} = 1 - \frac{\rho_d}{G_s \rho_w} \quad (5)$$

and

$$w_{sat} = \frac{\rho_w}{\rho_d} \theta_{sat} \quad (6)$$

where ρ_d is computed using Eq 2.

10.2 Water Contents at Other Suctions:

10.2.1 *Methods A and B*—Compute the volumetric water content corresponding to each i th increment in suction, θ_i , as:

$$\theta_i = \theta_{i-1} - (x_i - x_{i-1}) \frac{F}{V} \quad (7)$$

where θ_{i-1} is the volumetric water content at the previous suction, x_i is the location of the air-water interface after equilibrium has been established at the i th suction as described in 9.2.4, x_{i-1} is the location of the air-water interface after equilibrium was established for the previous increment in suction, F is the scale factor for the capillary tube relating volume to displacement of the air-water interface, and V is the volume of the sample. When $i = 1$, $\theta_{i-1} = \theta_{sat}$ and x_{i-1} is the initial reading for the air-water interface that was recorded after initially establishing equilibrium, as described in 9.2.3. The

gravimetric water content corresponding to each volumetric water content can be computed as:

$$w_i = \frac{\rho_w}{\rho_d} \theta_i \quad (8)$$

10.2.2 *Method C*—If duplicate specimens are tested, the gravimetric water content of the two replicate specimens shall be averaged for each suction, and the average shall be reported as the gravimetric water content for the applied suction. The volumetric water content corresponding to each gravimetric water content can be computed using:

$$\theta = \frac{\rho_d}{\rho_w} w \quad (9)$$

10.2.3 *Method E*—Compute the volumetric water content corresponding to each i th increment in suction, θ_i , as:

$$\theta_i = \theta_{i-1} - \frac{V_{di}}{V} \quad (10)$$

where θ_{i-1} is the volumetric water content at the previous suction, V_{di} is the volume of water displaced by the i th suction (or i th angular velocity), and V is the volume of the specimen (Eq 3). Compute the i th suction (in kPa) induced as:

$$\psi_i = \beta(\rho_w - \rho_g)\omega_i^2(r_b^2 - r_i^2) \quad (11)$$

where ρ_w is the density of the pore liquid (typically water, 1.0 kg/L), ρ_g is the density of the pore gas (typically assumed to be zero), ω is the angular velocity of the centrifuge (rpm), r_b is the outer radius of rotation (m), r_i is the inner radius of rotation (m), and β is a constant = 0.00553.

10.3 *Total Suctions and Water Content—Method D*—Calculate the total suction for the i th test (ψ_{ti}) using the water activity reported by the chilled mirror hygrometer and the Kelvin equation:

$$\psi_{ti} = \frac{RT}{M} \ln(a_w) \quad (12)$$

where a_w is the water activity, R is the gas constant, T is the laboratory temperature (°K), and M is the molecular mass of water. The value of R/M is 461 kPa/°K. Temperature in °K is obtained by adding 273° to the temperature in °C.

10.3.1 When suction corresponding to various water contents are measured using a single specimen (that is, by repeatedly drying the specimen), the gravimetric water content corresponding to the i th measurement of suction, w_i , is computed as:

$$w_i = w_o + \frac{M_i - M_o}{\rho_d V} \quad (13)$$

where w_o is the gravimetric water content determined using Method D 2216 for the first suction measurement, M_o is the mass of the specimen for the first suction measurement, M_i is the mass of the specimen for the i th suction measurement, ρ_d is the dry density at which the specimen was prepared, and V is the volume of the specimen. Volumetric water contents corresponding to the gravimetric water contents can be determined using Eq 9.

10.3.2 When suction are measured on individual specimens, the gravimetric water content of each specimen is measured using Method D 2216 after testing in the hygrometer. Volumetric water contents corresponding to these gravimetric water contents can be determined using Eq 9.

10.4 *Saturation*—If the soil water characteristic curve is to be reported in terms of saturation (S) rather than water content, compute the degree of saturation corresponding to each volumetric water content using:

$$S = \frac{\theta}{1 - \frac{\rho_d}{G_s \rho_w}} \quad (14)$$

or to convert gravimetric water content to saturation, use:

$$S = \frac{w}{\frac{\rho_w}{\rho_d} - \frac{1}{G_s}} \quad (15)$$

11. Report

11.1 The report shall include the following information:

11.1.1 Sample identifying information.

11.1.2 The type of water used to saturate and test the soil specimens.

11.1.3 The method of saturation (tray, saturation chamber, or saturating apron in a pressure chamber).

11.1.4 The method used to conduct the test (for example, Method A, B, C, D or E). For Methods B and C, state whether a porous plate or porous membrane was used, the air entry pressure of the porous plate or membrane. For Method D, state the brand and model of the hygrometer that was used. For Method E, state the manufacturer and model number for the centrifuge and specimen support chamber.

11.1.5 A description of the soil, any special characteristics of the specimen, and the selection and/or processing procedure (for example, removal of stones). For compacted materials, provide descriptive information on the method of compaction, the compaction water content, and the compacted dry unit weight.

11.1.6 Dimensions of test specimens.

11.1.7 Time required to reach equilibrium at each pressure step.

11.1.8 Approximate temperature of the soil during the test procedure (typically the air temperature of the laboratory) to the nearest 1°C.

11.1.9 A table reporting the gravimetric and volumetric water content corresponding to each suction.

11.1.10 For Methods A and B, report the gravimetric water content of the specimen after the last increment in suction was applied, as measured using Method D 2216. Report the corresponding volumetric water content, and the difference between this volumetric water content and that computed using Eq 6 for the final increment in suction.

11.1.11 The soil water characteristic curve; that is, a graph showing volumetric water content, gravimetric water content, or saturation as a function of suction. Three examples of soil water characteristic curves are shown in Fig. 12. The soil water characteristic curve in Fig. 12a was determined using Method A. Methods A, B, and D were combined to determine the soil water characteristic curve shown in Fig. 12b. The soil water characteristic curve in Fig. 12b illustrates how Method D can be used to define the dry end of the curve and Method A can be used to define the portion near saturation. The good match between the data from Methods B and D at the dry end indicates that equilibrium was established at the higher suctions when Method B was used. An example of a soil water characteristic curve determined solely with Method D is shown in Fig. 12c.

12. Precision and Bias

12.1 *Precision*—Test data on precision are not presented due to the nature of the geological materials tested by this test method. Having ten or more laboratories participate in a round-robin testing program is considered to be infeasible and too costly. Also, producing multiple specimens that have uniform physical properties is considered infeasible and too costly. Any variation observed in the data is just as likely to be due to specimen variation as to operator or laboratory testing variation.

12.1.1 Subcommittee D18.04 on Hydrologic Properties of Soil and Rock is seeking data from the users of this test method that might be used to make a limited statement on precision.

13. Keywords

13.1 capillary pressure; chilled mirror hygrometer; gravimetric water content; hanging column; matric potential; matric suction; pressure membrane; pressure plate; soil; soil water characteristic curve; suction; total suction; volumetric water content; water activity

ASTM International takes no position respecting the validity of any patent rights asserted in connection with any item mentioned in this standard. Users of this standard are expressly advised that determination of the validity of any such patent rights, and the risk of infringement of such rights, are entirely their own responsibility.

This standard is subject to revision at any time by the responsible technical committee and must be reviewed every five years and if not revised, either reapproved or withdrawn. Your comments are invited either for revision of this standard or for additional standards and should be addressed to ASTM International Headquarters. Your comments will receive careful consideration at a meeting of the responsible technical committee, which you may attend. If you feel that your comments have not received a fair hearing you should make your views known to the ASTM Committee on Standards, at the address shown below.

This standard is copyrighted by ASTM International, 100 Barr Harbor Drive, PO Box C700, West Conshohocken, PA 19428-2959, United States. Individual reprints (single or multiple copies) of this standard may be obtained by contacting ASTM at the above address or at 610-832-9585 (phone), 610-832-9555 (fax), or service@astm.org (e-mail); or through the ASTM website (www.astm.org).