



Designation: D 370 – 02

American Association State
Highway Transportation Officials Standard
AASHTO No. T 83

Standard Practice for Dehydration of Oil-Type Preservatives¹

This standard is issued under the fixed designation D 370; the number immediately following the designation indicates the year of original adoption or, in the case of revision, the year of last revision. A number in parentheses indicates the year of last reapproval. A superscript epsilon (ϵ) indicates an editorial change since the last revision or reapproval.

1. Scope

1.1 This practice covers dehydrating oil-type preservatives. When a quantitative determination of the amount of water is desired, Test Method D 95 shall be used. Test Methods D 38 covers the sampling of wood preservatives prior to testing.

1.2 *This standard does not purport to address all of the safety concerns, if any, associated with its use. It is the responsibility of the user of this standard to establish appropriate safety and health practices and determine the applicability of regulatory limitations prior to use.*

2. Referenced Documents

2.1 ASTM Standards:

D 38 Test Methods for Sampling Wood Preservatives Prior to Testing²

D 95 Test Method for Water in Petroleum Products and Bituminous Materials by Distillation³

E 1 Specification for ASTM Thermometers⁴

3. Summary of Test Method

3.1 Water is removed from the preservative solution by distillation in a copper still.

4. Significance and Use

4.1 This is a practice for the preparation of oil-type preservatives to enable the results of distillation tests to be reported more accurately on a dry basis.

¹ This practice is under the jurisdiction of ASTM Committee D07 on Wood and is the direct responsibility of Subcommittee D07.06 on Treatments for Wood Products.

Current edition approved Dec. 10, 2002. Published February 2003. Originally approved in 1933 as D 370 – 33 T. Last previous edition approved in 1995 as D 370 – 84 (1995) ^{ϵ 1}.

This practice is substantially in agreement with the Standard Method for the Determination of Water in Oil-Type Preservatives which is part of the American Wood-Preservers' Association Standard Methods for Analysis of Creosote and Oil-Type Preservatives (A1). Acknowledgement is made to the American Wood-Preservers' Association for its development of the subject matter covered in this standard.

² *Annual Book of ASTM Standards*, Vol 04.10.

³ *Annual Book of ASTM Standards*, Vol 05.01.

⁴ *Annual Book of ASTM Standards*, Vol 14.03.

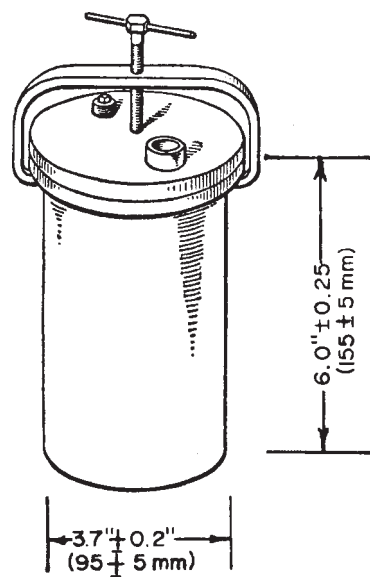

FIG. 1 Copper Still

5. Apparatus

5.1 *Still*—A vertical, cylindrical copper still, with removable flanged top and yoke, of the form and approximate dimensions shown in Fig. 1.

5.2 *Thermometer*—An ASTM High Distillation Thermometer, total immersion, graduated in either Celsius or Fahrenheit degrees as specified, having a range from -2 to $+400^{\circ}\text{C}$ or 30 to 760°F , and conforming to the requirements for Thermometer 8C or 8F as prescribed in Specification E 1.

5.3 *Condenser*—A copper trough condenser, with straight-walled glass tube, having approximately the form and dimensions shown in Fig. 2.

5.4 *Separatory Funnel*, conforming to the requirements shown in Fig. 3. It shall have a total capacity of approximately 200 mL, with the lower 20 mL graduated accurately in 0.1 mL. The graduation marks shall be numbered for each millilitre. A separatory funnel of the Squibb type, having a capacity of approximately 100 mL, may be used.

ASTM D 370 - 02

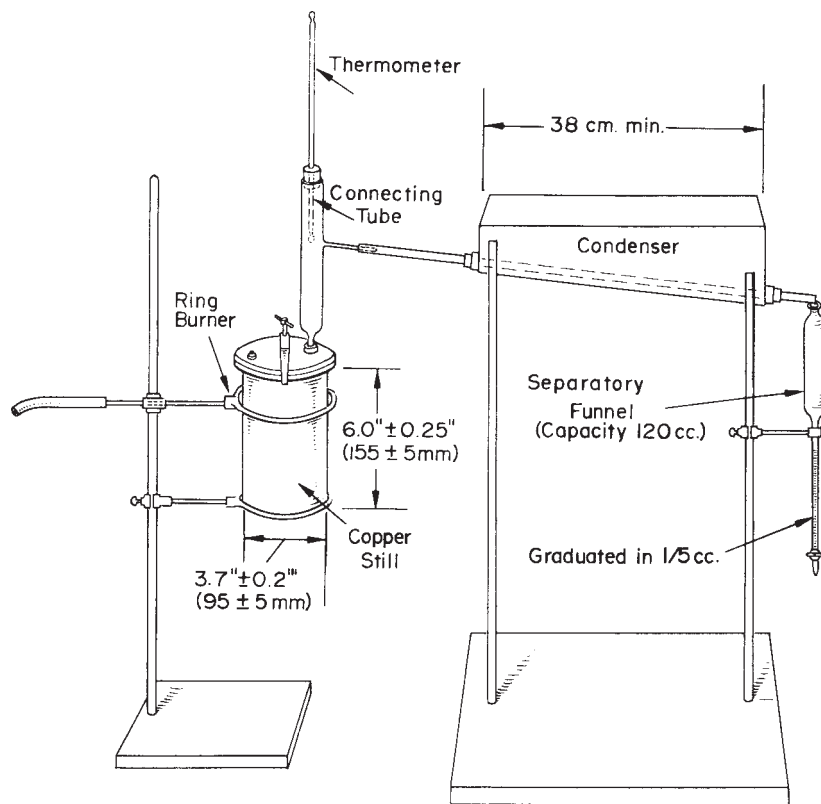

FIG. 2 Assembled Apparatus for Water Test

6. Apparatus Assembly

6.1 The apparatus shall be assembled as shown in Fig. 2.

7. Sample

7.1 The portion of the sample removed for dehydration must be representative of the total sample. Thoroughly stir the sample as received, warming if necessary to ensure liquidity and uniformity, and remove a representative portion for dehydration.

8. Procedure

8.1 Transfer 200 to 300 mL of the portion of the sample removed for dehydration to the copper still (Note 1). Clamp the lid on, using a paper gasket slightly wet with oil under test around the flange of the still. Apply heat by means of the ring burner, which shall be placed just above the level of the oil in the still at the beginning of the dehydration and gradually lowered when most of the water has distilled over. Continue

the distillation until the vapor temperature reaches 205°C , as indicated by the thermometer with the bulb opposite the off-take of the connecting tube. Collect the distillate in the separatory funnel. When the distillation is completed, and a clear separation of water and oil in the funnel has taken place (Note 2), return any light oil distilled over with the water to the oil in the still and mix thoroughly before further testing.

NOTE 1—When free water is present in the portion of the sample removed for dehydration, separate, if possible, before the transfer.

NOTE 2—Separation of water and oil in the separatory funnel may be more readily accomplished by the addition of a concentrated solution of sodium chloride and slight heating.

9. Precision and Bias

9.1 No information is presented about either the precision or bias of Practice D 370 since the test result is non-quantitative.

10. Keywords

10.1 dehydration; oil-type; preservative

 **D 370 – 02**

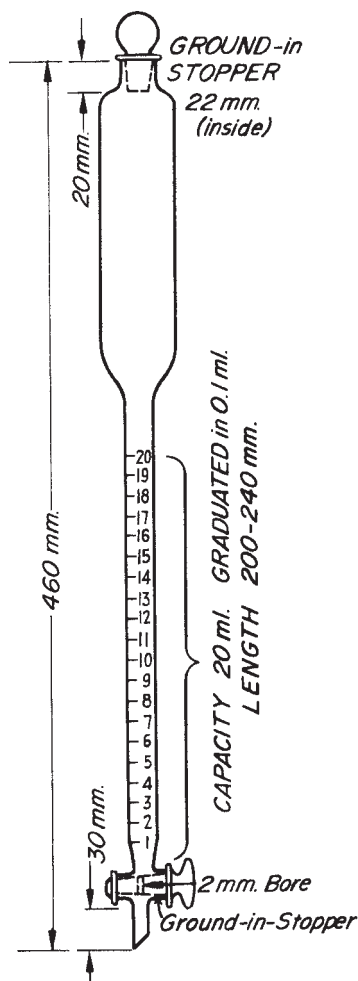

FIG. 3 Glass Separatory Funnel, 200-mL Capacity

ASTM International takes no position respecting the validity of any patent rights asserted in connection with any item mentioned in this standard. Users of this standard are expressly advised that determination of the validity of any such patent rights, and the risk of infringement of such rights, are entirely their own responsibility.

This standard is subject to revision at any time by the responsible technical committee and must be reviewed every five years and if not revised, either reapproved or withdrawn. Your comments are invited either for revision of this standard or for additional standards and should be addressed to ASTM International Headquarters. Your comments will receive careful consideration at a meeting of the responsible technical committee, which you may attend. If you feel that your comments have not received a fair hearing you should make your views known to the ASTM Committee on Standards, at the address shown below.

This standard is copyrighted by ASTM International, 100 Barr Harbor Drive, PO Box C700, West Conshohocken, PA 19428-2959, United States. Individual reprints (single or multiple copies) of this standard may be obtained by contacting ASTM at the above address or at 610-832-9585 (phone), 610-832-9555 (fax), or service@astm.org (e-mail); or through the ASTM website (www.astm.org).