

This document is not an ASTM standard and is intended only to provide the user of an ASTM standard an indication of what changes have been made to the previous version. Because it may not be technically possible to adequately depict all changes accurately, ASTM recommends that users consult prior editions as appropriate. In all cases only the current version of the standard as published by ASTM is to be considered the official document.



---

**Designation: D 3957 – 90 (Reapproved 2002)**



**Designation: D 3957 – 03**

## **Standard Practices for Establishing Stress Grades for Structural Members Used in Log Buildings<sup>1</sup>**

This standard is issued under the fixed designation D 3957; the number immediately following the designation indicates the year of original adoption or, in the case of revision, the year of last revision. A number in parentheses indicates the year of last reappraisal. A superscript epsilon ( $\epsilon$ ) indicates an editorial change since the last revision or reappraisal.

### **INTRODUCTION**

These practices are based on the assumption that structural members in log buildings can be stress-graded by methods that derive from accepted standards for conventional solid sawn lumber and round timbers. It is assumed that the material to be graded bears enough similarity to either sawn lumber or round timber, both in dimensional properties and in use, to warrant application of stress-grading standards written for sawn-lumber or round-timber, or both. These practices, such as Practices D 245 and D 2899, cannot be applied directly because the structural members used in log buildings are generally neither perfectly rectangular nor perfectly round in section. These practices use certain conventions regarding cross-sectional dimensions that make it possible to extend established stress-grading methodologies to cover the members used in log buildings.

Where log member characteristics deviate from sawn lumber or round timber standards, there may be uncertainty as to the exact effect of the deviation on strength properties. To compensate for this uncertainty, some design stress values are herein derived with practices that are, by engineering judgment, conservative. The philosophy guiding this approach is that while the absence of experimental data may make a measure of conservatism unavoidable, the reliability of design stress values must not be achieved through wood quality or size requirements that are an unnecessary burden on the wood resource.

In general, the sawing, cutting, and shaving required to bring a piece to its final shape must be completed before it can be visually graded using the principles in these practices. Small cuts may be allowed after grading if it can be shown that either (1) the cuts do not affect the grade, or (2) the grade takes the additional cuts into consideration.

Both sawn lumber standards and round timber standards are herein referenced, because these two stress-grading methodologies can be assumed to apply to two different types of structural members used in log buildings: wall-logs and round timber beams. Since wall-logs must be provided with a means of joining together (for example, tongue-and-groove joints), they resemble sawn lumber and are treated as such in the standard. Rafters, purlins, and beams, on the other hand, are sometimes left as round logs, except for a small amount of sawing to provide a flat nailing surface. These practices thus deal with stress-grading of wall-logs and round-timber beams separately.

---

<sup>1</sup> These practices are under the jurisdiction of ASTM Committee D07 on Wood and are the direct responsibility of Subcommittee D07.02 on Lumber and Engineered Wood Products.

Current edition approved April 27, 1990; Oct. 1, 2003. Published May 1990; November 2003. Originally published as D 3957 – 80; approved in 1980. Last previous edition D 3957 – 80 (1984); approved in 1990 as D 3957 – 90 (2002).

### **1. Scope**

1.1 These practices cover the visual stress-grading principles applicable to structural wood members of nonrectangular shape, as typically used in log buildings. These practices are meant to supplement the ASTM standards listed in Section 2, which cover stress-grading of sawn lumber and round timbers. Pieces covered by these practices may also be used in building types other than log buildings.

1.2 The grading provisions used as illustrations herein are not intended to establish grades for purchase, but rather to show how stress-grading principles are applied to members used in log buildings. Detailed grading rules for commercial stress grades which serve as purchase specifications are established and published by agencies that formulate and maintain such rules and operate inspection facilities covering the various species.

1.3 *This standard does not purport to address all of the safety concerns, if any, associated with its use. It is the responsibility*

*of the user of this standard to establish appropriate safety and health practices and determine the applicability of regulatory limitations prior to use.*

## **2. Referenced Documents**

2.1 *ASTM Standards:*<sup>2</sup>

D 9 Terminology Relating to ~~Wood~~<sup>2</sup>  
Wood

---

<sup>2</sup> For referenced ASTM standards, visit the ASTM website, [www.astm.org](http://www.astm.org), or contact ASTM Customer Service at [service@astm.org](mailto:service@astm.org). For Annual Book of ASTM Standards, Vol 04.10, volume information, refer to the standard's Document Summary page on the ASTM website.

D 25 Specification for Round Timber Piles

D 245 Practice for Establishing Structural Grades and Related Allowable Properties for Visually Graded Lumber

D 2555 Test Methods for Establishing Clear Wood Strength Values

D 2899 Practice for Establishing Allowable Stresses for Round Timber Piles

D 3200 Specification and Test Methods for Establishing Recommended Design Stresses for Round Timber Construction Poles

### 3. Stress-Grading of Wall-Logs

#### 3.1 General:

3.1.1 This section is intended to apply to wood members, referred to as wall-logs, which are normally stacked horizontally or laid-up vertically to form a load-bearing, solid-wood wall, in any building. These structural members can vary greatly in dimension and section profile, and therefore previously developed standards for solid sawn lumber are not readily applied to them (Fig. 1).

3.1.2 Wall-logs, as referred to in these practices, can also be used as beams, joists, and so forth, and do not have to be used as wall components.

3.1.3 Unless they qualify as round-timber beams under Section 4 of these practices, wall-logs must be considered as sawn lumber and therefore must respect the provisions of stress-grading described in Practice D 245. The manner in which Practice D 245 is applied to wall-logs is described in 3.2.

#### 3.2 Use of Rectangular Section Inscribed in Actual Sections:

3.2.1 A wall-log is to be graded as the largest piece of rectangular lumber that can be embedded in the wall-log without protrusion from any wall-log surface except that each corner may protrude up to 1/2 in. in either or both directions (Fig. 2). All provisions of Practice D 245 that would apply to a piece with the same cross section as the inscribed rectangle shall apply to the wall-log.

3.2.2 Maximum knot sizes shall be determined by the wide and narrow face dimensions of the inscribed rectangle, using knot tables in Practice D 245. Boundaries between portions of the wall-log surface considered "wide-face" and portions considered "narrow-face" shall be found by extending the diagonals of the inscribed rectangle to the wall-log surface (Fig. 3). Just as the wide and narrow faces of the inscribed rectangle belong to a quadrant between diagonals, so shall the wide and narrow faces of the wall-log surface belong to the same quadrants. In general, then, the surface boundaries between wide and narrow faces may not coincide with actual edges on the wall-log.

3.2.3 Knot size limitations, as determined by the dimensions of the inscribed rectangle, shall apply to knot measurements taken at the surface of the wall-log. The slight difference between the knot size at the surface of the wall-log, and the knot size at the inscribed rectangle is, for practical purposes, disregarded.

3.2.4 If the wall-log design has saw-cuts that penetrate deeply into the piece, then any "inscribed rectangle" that remains

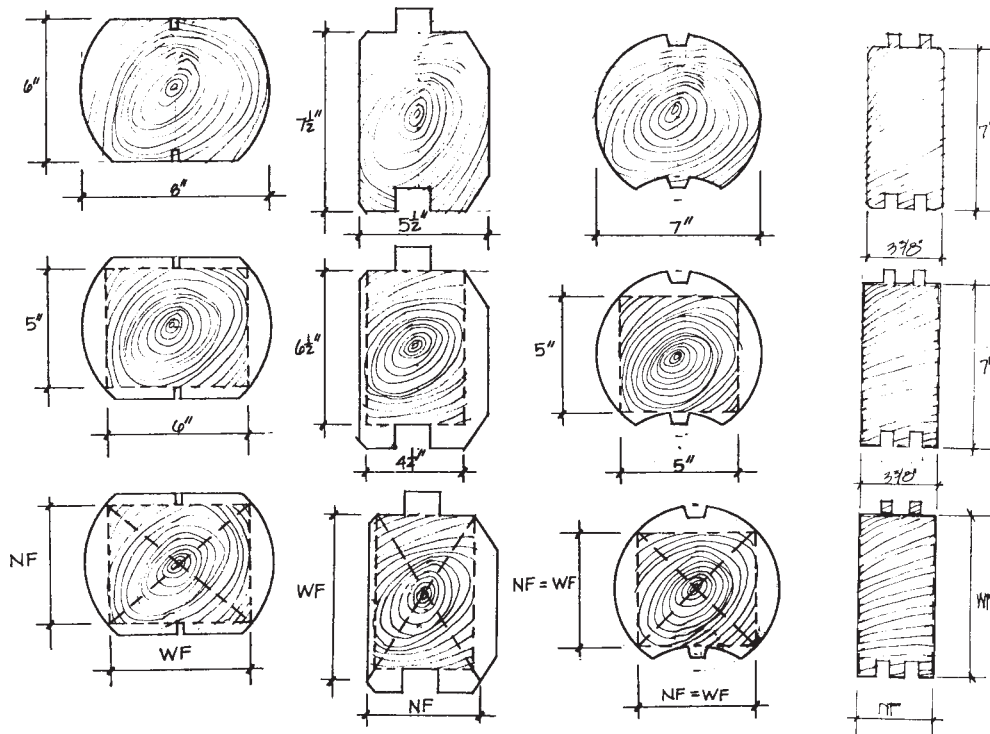

NF—Narrow Face  
WF—Wide Face

FIG. 1 Typical Wall-Log Sections Showing Wide and Narrow Faces as Determined by Inscribed Rectangle

— Narrow face    — Wide Face

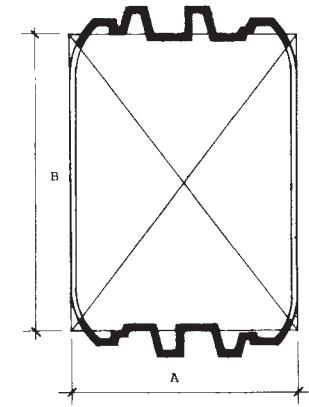

(a) Wall-Log Without Saw Kerf: Maximum allowable narrow face knot,  $D$ , determined for  $A \times B$  inscribed rectangle.

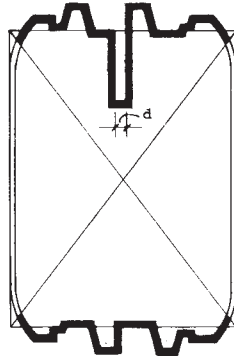

(b) Same Wall-Log, With Saw Kerf: Maximum allowable narrow face knot =  $D - d$  (top) and  $D$  (bottom).

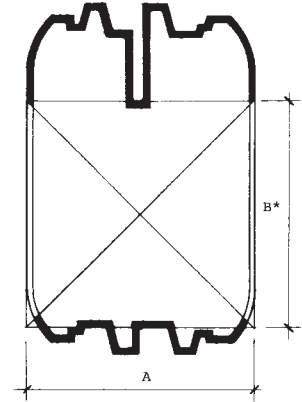

(c) Alternative Method: Maximum allowable narrow face knot,  $D^*$ , determined for  $A \times B^*$  inscribed rectangle.

FIG. 2 Determination of Inscribed Rectangle

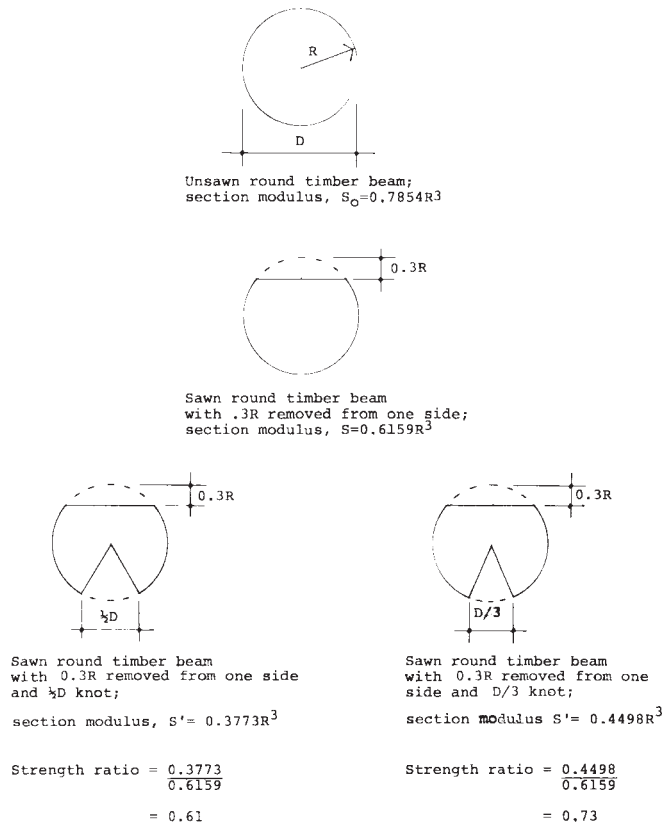

FIG. 3 Strength Ratio for Sawn Round Timber Beam

unpenetrated by sawing may be too small to use for determining knot limitations. To accommodate wall-logs of this type, cuts into the inscribed rectangle may be treated as follows.

3.2.4.1 If a face of an inscribed rectangle has a maximum allowable knot size of  $D$  inches when the face is unpenetrated by any cuts, then the maximum allowable knot size for knots that do not encompass the sawcut is reduced to  $D - d$  inches when the face is penetrated by a cut  $d$  inches wide. That is, a saw cut  $\frac{1}{2}$  in. wide could effectively increase a 2-in. knot to  $2\frac{1}{2}$  in., as when the knot and the cut are tangent to each other. Therefore, a cut  $\frac{1}{2}$  in. wide will reduce the maximum allowable knot by  $\frac{1}{2}$  in. (Fig. 3).

3.2.4.2 As an alternate to 3.2.4.1, reduce the maximum allowable knot displacement  $D$  to  $D - 2d$  where  $d$  is the displacement of the sawcut(s) when the knot does not encompass the sawcut. For example, a 6 by 12 in. with maximum knot displacement of 50 %, and two grooves  $\frac{3}{4}$  by 1 in. each on one narrow face, a groove displacement of 2 %, the allowable knot displacement for

knots that do not encompass the grooves would be reduced to  $50 - 2(2) = 46\%$ .

#### 4. Stress-Grading of Sawn Round Timber Beams

##### 4.1 General:

4.1.1 This section describes how the formulas of Practice D 2899 are applied to round timbers that are shaved or sawn along one side (Note 1). Since these members are normally loaded on their flat surface, they are stressed primarily in bending and are herein referred to as sawn round timber beams.

NOTE 1—Un-sawn round timbers used in the superstructure of buildings are covered by Specification and Test Methods D 3200.

4.1.2 Specification D 25 and Practice D 2899 set forth one structural grade. These practices supplement Specification D 25 and Practice D 2899 so that a series of grades can be constructed. This is accomplished by means of the strength ratios defined in 4.5.

##### 4.2 Allowable Sawing:

4.2.1 The flat side of a sawn round timber beam shall not penetrate more than  $0.3R$  into the piece, where  $R$  is the radius of the beam (Fig. 2). This limits the reduction of the cross-sectional area, by sawing or shaving, to less than 10%.

4.2.2 A “form factor” equal to 1.18 is the factor by which design-bending stresses of square-sawn pieces are multiplied in order to derive design-bending stresses for beams with circular cross-sections. Since sawn round timber beams do not have a circular cross section, their form factor is set equal to 1.0 rather than 1.18. In order to apply the bending stress formula of Practice D 2899 to sawn round timber beams, the form factor included in that formula must be set equal to 1.0.

4.3 *Knot Measurement*—Knots on the sawn face of a sawn round timber beam are measured by their smallest diameter. Other knots are measured in accordance with Specification D 25.

4.4 *Slope of Grain Measurement*—Slope of grain in sawn round timber beams is measured by the angle between the direction of the fibers and the axis of the piece. As for lumber, this angle is expressed as a slope.

##### 4.5 Design Bending Stress Values :

4.5.1 Bending strength ratios are determined by slope of grain or knot size, whichever is most restrictive. The substitution of alternative strength ratios into the design stress formula of Practice D 2899 is not meant to result in higher allowable bending stresses than can be obtained when the bending strength ratio equals 0.76, that is, bending strength ratios higher than 0.76 are not recommended for sawn round timber beams.

NOTE 2—The formula in Practice D 2899 for finding design bending stress values assumes that clear wood bending strength values should be reduced by a factor of 0.9 to account for “form and grade.” Since the form factor for round timbers is 1.18, the strength ratio for grade restrictions in Specification D 25 is 0.76. To provide for other grade descriptions in sawn round timber beams, a strength ratio system similar to Practice D 245 application to sawn lumber is proposed.

4.5.1.1 *Knot Strength Ratios*—Strength ratios for sawn round timber beams shall be determined assuming that knots effectively reduce the cross-sectional area by a pie-shaped sector that radiates from the center of the beam to the outermost boundaries of the knot (Fig. 3). It is further assumed that the sector of area lost to a knot lies opposite the sawn face, since this will most reduce the beam’s section modulus.

(a) Given (1) the section modulus,  $S$ , of a beam sawn to the limit of 4.2.1, and (2) the section modulus,  $S'$ , obtained when  $S$  is reduced to account for a knot, the bending strength ratio associated with the knot is that number that when multiplied by  $S$  gives  $S'$ .

(b) By substituting the above strength ratios into the Practice D 2899 bending stress formula as explained in Appendix X1 and by the application of the other adjustments to this formula described in 4.2.2 and 4.5.3, design bending stress values for specific knot sizes can be determined.

4.5.1.2 *Slope of Grain Strength Ratios*— The exact relationship between slope of grain and bending strength has not been determined for unsawn round timbers. These strength ratios, listed below, are thought to be conservative estimates of the effect of slope of grain on sawn round timber beams (Note 3):

Slope of Grain	Bending Strength Ratio, %
1 in 4	27
1 in 6	40
1 in 8	53
1 in 10	61
1 in 12	69
1 in 14	74
1 in 15	76

NOTE 3—Round timbers that are sawn within the limitations stated in 4.2 will have hybrid strength characteristics that are between those of sawn lumber and round timber. It can be assumed that the effect of a given slope of grain on the bending strength of sawn round timber beams will not be as great as its effect on the bending strength of sawn lumber. This assumption, which is based on engineering judgment, allows for the application of the above strength ratios to sawn round timber beams.

4.5.2 In addition to factors for form and grade, the Practice D 2899 formula for design bending stress includes factors to account for load duration, tip weakness, and variability. These factors are also applied to sawn round timber beams.

4.5.3 A formal factor of safety of 1.3 shall be included in the formula for design bending stresses used for sawn round timber beams.

#### 4.6 Other Design Stresses:

4.6.1 *Tension-Parallel-to-Grain*—Design values for tension-parallel-to-grain in sawn round timber beams shall be taken to be 55 % of design bending stresses, in accordance with the convention for lumber recommended by Practice D 245.

4.6.2 *Compression-Parallel-to-Grain*—For sawn round timber beams, the strength ratio for compression-parallel-to-grain shall be taken to be equal to the bending strength ratio described in 4.5.1. This strength ratio is to be used in the Practice D 2899 formula for compression-parallel-to-grain, as explained in Appendix X1.

4.6.3 *Shear*—The Practice D 2899 shear formula can be used for sawn round timber beams.

4.6.4 *Compression-Perpendicular-to-Grain*—The Practice D 2899 compression-perpendicular-to-grain formula can be used for sawn round timber beams.

4.6.5 *Modulus of Elasticity*—Divide the average small clear modulus of elasticity from Test Methods D 2555 by 0.94 to obtain the design value for modulus elasticity. Quality factors, for strength ratios less than 55 %, are applied to the modulus of elasticity values of sawn round timber beams, in accordance with Table 7 of Practice D 245.

4.7 Those limitations on decay, insect attack, straightness, holes, scars, checks, shakes, and splits described in Specification D 25 shall apply to all grades of sawn round timber beams.

### 5. Example of Stress-Grade Development

5.1 *Wall-Log Grade*—This example is for the wall-log shown in Fig. 2(a), for which the inscribed rectangle is assumed to be 5 by 6 in. (actual dimensions). It is desired to base the grade on a bending strength ratio of 0.61, so that the slope-of-grain limitation is 1:10. The strength ratio for compression parallel to grain is the same as the strength ratio associated with maximum allowable wide face knots (Practice D 245, Table 3), and is selected to be as near 0.61 as possible. No limitation on checks, shakes, or splits is desired, so the shear strength ratio is taken to be 0.50. Design bending stress values for both narrow and wide face loads are required. For this wall-log, narrow face loads correspond to vertical loads; wide face loads correspond to lateral loads.

5.1.1 *Maximum Allowable Knot Sizes*—Since the piece is subject to loading on both the 5 and 6-in. faces, each of these faces must have knot limitations that satisfy both “wide face” requirements (Practice D 245, Table 3) and “narrow face” requirements (Practice D 245, Table 1).

Under vertical loads (loads on 5-in. face):

Maximum knot allowed on 5-in. face (Table 2):  $2\frac{1}{8}$  in.

Maximum knot allowed on 6-in. face (Table 3):  $2\frac{1}{2}$  in.

Under lateral loads (loads on 6-in. face):

Maximum knot allowed on 5-in. face (Table 3):  $2\frac{1}{8}$  in. by interpolation

Maximum knot allowed on 6-in. face (Table 2):  $2\frac{1}{2}$  in.

5.1.1.1 In this case, the limitations imposed under the two different conditions of load are the same, and maximum knot sizes can be summarized as follows:

Maximum knot on 5-in. face:  $2\frac{1}{8}$  in.

Maximum knot on 6-in. face:  $2\frac{1}{2}$  in.

5.1.2 *Design Stress Values*—Table 1 illustrates the development of design stress values from clear wood strength values. The stresses in Table 1 are for Eastern White Pine.

5.2 *Sawn Round Timber Beam Grade*—This example is for sawn round timber beam 8 in. in diameter, sawn to the limit of  $0.3R = 0.3(4) = 1.2$  in. It is desired to limit knots to  $D/3 = 8/3 = 2.67$  in., which results in a bending strength ratio for knots of 0.73 (Fig. 3). At this bending strength ratio, slope of grain is limited to 1:14.

5.2.1 *Design Stress Values*—Table 2 illustrates the development of design stress values from clear wood strength values. The stresses are for Eastern White Pine.

### 6. Keywords

6.1 log building; round timber beams; stress grades; structural members; wall logs

**TABLE 1 Stress-Grade Development for Example Wall-Log**

NOTE 1—Average clear wood strength values,  $S$ , and the standard deviation of these values,  $SD$ , are provided for various species in Test Methods D 2555. Values shown for  $F_b$ ,  $F_t$ ,  $F_v$ , and  $F_c$  represent the 5 % exclusion limit of  $S - 1.645 SD$ . The values shown for  $F_c$  and  $E$  are left as averages,  $S$ , that are not adjusted for variability.

NOTE 2—The special factors shown are as follows:

- 0.9032 = depth factor, as defined in 6.3 of Practice D 245,
- 0.9032 = depth factor, as defined in 7.2 of Practice D 245,
- 0.8851 = depth factor, as defined in 6.3 of Practice D 245,
- 0.8851 = depth factor, as defined in 7.2 of Practice D 245,
- 0.55 = adjustment specified by 4.2.5 of Practice D 245,
- 1.10 = seasoning adjustment specified by 7.1.3 of Practice D 245,
- 1.50 = seasoning adjustment factor specified by Table 11 of Practice D 245, and
- 1.50 = seasoning adjustment factor specified by Table 10 of Practice D 245, and
- 1.00 = quality factors specified by Table 7 of Practice D 245.
- 1.06 = consisting of a quality factor of 1.00, as specified by Table 5 of Practice D 245 and another factor of 1/0.94, which adjusts a span-to-depth ratio of 14 and center-point load to a span-to-depth ratio of 21 and an assumed uniform load.

Property	Clear Wood Strength (Note 1), psi (MPa)	Adjustment for Du- ration of Load and Factor of Safety	Strength Ratio	Special Adjustment Fac- tors (Note 2)	Unrounded Value, psi (MPa)	Design Value, psi (MPa)
$F_b$ , lateral load	3632 (25.04)	1/2.1	0.61	0.9032	953 (6.57)	950 (6.6)
$F_b$ , vertical load	3632 (25.04)	1/2.1	0.61	0.8851	934 (6.44)	925 (6.4)
$F_t$	3632 (25.04)	1/2.1	0.61	0.55	580 (4.00)	575 (4.0)
$F_v$	<del>522 (3.60)</del>	<del>1/4.1</del>	<del>0.50</del>	<del>none</del>	<del>64 (0.439)</del>	<del>65 (0.44)</del>
$F_v$	522 (3.60)	1/4.1	0.50	NA	64 (0.439)	65 (0.44)
$F_c$	1718 (11.85)	1/1.9	0.62	1.10	617 (4.25)	625 (4.3)
$F_c$	<del>218 (1.50)</del>	<del>1/1.5</del>	<del>1.00</del>	<del>1.50</del>	<del>218 (1.5)</del>	<del>220 (1.5)</del>
$F_{c1}$	218 (1.50)	1/1.5	1.00	1.50	218 (1.5)	220 (1.5)
$E$	<del><math>0.994 \times 10^6</math> (6850)</del>	<del>1/0.94</del>	<del>...</del>	<del>1.00</del>	<del><math>1.057 \times 10^6</math> (7287)</del>	<del><math>1.1 \times 10^6</math> (7500)</del>
$E$	$0.994 \times 10^6$ (6850)	NA	NA	1.06	$1.06 \times 10^6$ (7287)	$1.1 \times 10^6$ (7500)

**TABLE 2 Stress-Grade Development for Example Sawn Round Timber**

NOTE 1—Average clear wood strength values,  $S$ , and the standard deviation of these values,  $SD$ , are provided for various species in Test Methods D 2555. Values shown for  $F_b$ ,  $F_t$ ,  $F_v$ , and  $F_c$  represent the 5 % exclusion limit of  $S - 1.645 SD$ . The values shown for  $F_c$  and  $E$  are left as averages,  $S$ , that are not adjusted for variability.

NOTE 2—The special factors shown are as follows:

- 0.88 = factor for tip weakness and variability, as given in Appendix X1,
- 0.55 = adjustment specified by 4.3.5 of Practice D 245,
- 1.10 = seasoning adjustment factor specified by 7.1.3 of Practice D 245, and
- 1.10 = seasoning adjustment factor specified by 7.1.3 of Practice D 245,
- 1.50 = seasoning adjustment factor specified by Table 10 of Practice D 245, and
- 1.06 = consisting of a quality factor of 1.00, as specified in Table 5 of Practice D 245 and another factor of 1/0.94, which adjusts a span-to-depth ratio of 14 and center-point load to a span-to-depth ratio of 21 and an assumed uniform load.

Property	Clear Wood Strength (Note 1), psi (MPa)	Adjustment for Du- ration of Load and Factor of Safety	Strength Ratio	Special Adjustment Factors (Note 2)	Unrounded Value, psi (MPa)	Design Value, psi (MPa)
$F_b$	3632 (25.04)	1/2.1	0.73	0.88	1111 (7.66)	1100 (7.7)
$F_t$	3632 (25.04)	1/2.1	0.73	(0.88) (0.55)	611 (4.21)	600 (4.2)
$F_v$	522 (3.60)	1/4.1	0.75	...	95 (0.659)	95 (0.66)
$F_c$	1718 (11.85)	1/1.9	0.73	1.10	726 (5.01)	725 (5.0)
$F_c$	<del>218 (1.50)</del>	<del>1/1.5</del>	<del>1.00</del>	<del>1.50</del>	<del>218 (1.5)</del>	<del>220 (1.5)</del>
$F_{c1}$	218 (1.50)	1/1.5	1.00	1.50	218 (1.5)	220 (1.5)
$E$	<del><math>0.994 \times 10^6</math> (6850)</del>	<del>1/0.94</del>	<del>...</del>	<del>...</del>	<del><math>1.057 \times 10^6</math> (7287)</del>	<del><math>1.1 \times 10^6</math> (7500)</del>
$E$	$0.994 \times 10^6$ (6850)	NA	NA	...	$1.06 \times 10^6$ (7287)	$1.1 \times 10^6$ (7500)

## APPENDIX

### (Nonmandatory Information)

#### X1. FORMULAS FOR DETERMINING BENDING AND COMPRESSION-PARALLEL-TO-GRAIN DESIGN STRESS VALUES, FOR SAWN ROUND TIMBER BEAMS

X1.1 The formula for deriving the design bending stress for sawn round timber beams is as follows:

$$F_b = \frac{(S - 1.645SD)(0.88)(SR)}{(1.62)(1.30)}$$

where:

- $S$  = small clear bending strength from Test Methods D 2555,
- $SD$  = standard deviation of small clear bending strength, from Test Methods D 2555,
- $SR$  = strength ratio calculated in accordance with 4.5.1,
- 0.88 = factor incorporated in Practice D 2899 bending stress, formula, adjusting clear wood strength,  $S$ , and standard deviation,  $SD$ , in accordance with pile test data,
- 1.62 = duration of load factor, and
- 1.30 = factor of safety.

X1.1.1 Combining factors, the formula becomes:

$$F_b = \frac{(S - 1.645SD)(SR)}{2.39}$$

X1.1.2 To obtain the same bending stress formula that appears in Practice D 2899: (1) multiply by a form factor of 1.18; (2) set the strength ratio equal to 0.76; and (3) cancel the factor of safety by multiplying by 1.30.

X1.2 The formula for deriving the compression-parallel-to-grain design stress is as follows:

$$F_c = \frac{(S - 1.645 SD)(0.90)(SR)}{(1.52)(1.25)}$$

where:

- $S$  = clear wood parallel-to-grain crushing strength from Test Methods D 2555,
- $SD$  = standard deviation of clear wood parallel-to-grain crushing strength, from Test Methods D 2555,
- $SR$  = strength ratio in accordance with 4.6.2,
- 0.90 = factor incorporated in Practice D 2899 compression-parallel-to-grain formula, adjusting clear wood strength,  $S$ , and standard deviation,  $SD$ , according to pile test data,
- 1.52 = duration of load factor, and
- 1.25 = factor of safety.

X1.2.1 Combining factors, the formula becomes:

$$F_c = \frac{(S - 1.645SD)(SR)}{2.11}$$

X1.2.2 To obtain the same compression-parallel-to-grain formula that appears in Practice D 2899: (1) set the strength ratio equal to 0.9; and (2) cancel the factor of safety by multiplying by 1.25.

*ASTM International takes no position respecting the validity of any patent rights asserted in connection with any item mentioned in this standard. Users of this standard are expressly advised that determination of the validity of any such patent rights, and the risk of infringement of such rights, are entirely their own responsibility.*

*This standard is subject to revision at any time by the responsible technical committee and must be reviewed every five years and if not revised, either reapproved or withdrawn. Your comments are invited either for revision of this standard or for additional standards and should be addressed to ASTM International Headquarters. Your comments will receive careful consideration at a meeting of the responsible technical committee, which you may attend. If you feel that your comments have not received a fair hearing you should make your views known to the ASTM Committee on Standards, at the address shown below.*

*This standard is copyrighted by ASTM International, 100 Barr Harbor Drive, PO Box C700, West Conshohocken, PA 19428-2959, United States. Individual reprints (single or multiple copies) of this standard may be obtained by contacting ASTM at the above address or at 610-832-9585 (phone), 610-832-9555 (fax), or [service@astm.org](mailto:service@astm.org) (e-mail); or through the ASTM website ([www.astm.org](http://www.astm.org)).*