



Standard Test Method for Combustible Properties of Treated Wood by the Fire-Tube Apparatus¹

This standard is issued under the fixed designation E 69; the number immediately following the designation indicates the year of original adoption or, in the case of revision, the year of last revision. A number in parentheses indicates the year of last reapproval. A superscript epsilon (ε) indicates an editorial change since the last revision or reapproval.

1. Scope

1.1 This test method covers fire-tube test procedures for fire tests for combustible properties of wood treated to reduce flammability. This test method relates to properties of treated wood, as such, rather than to the performance of a fabrication used as an element of construction. Performance under this test method shall be as prescribed in requirements applicable to materials intended for specific uses.

1.2 This test method is a fire-test-response standard.

1.3 The SI values given in parentheses are provided for information purposes only.

1.4 *This standard should be used to measure and describe the properties of materials, products, or assemblies in response to heat and flame under controlled laboratory conditions and should not be used to describe or appraise the fire hazard or fire risk of materials, products, or assemblies under actual fire conditions. However, results of this test may be used as elements of a fire risk assessment which takes into account all of the factors which are pertinent to an assessment of the fire hazard of a particular end use.*

1.5 *This standard does not purport to address all of the safety concerns, if any, associated with its use. It is the responsibility of the user of this standard to establish appropriate safety and health practices and determine the applicability of regulatory limitations prior to use.*

2. Referenced Documents

2.1 *ASTM Standards:*

D 9 Terminology Relating to Wood²

E 176 Terminology of Fire Standards³

3. Terminology

3.1 *Definitions*—For definitions of terms found in this test method, refer to Terminologies D 9 and E 176.

¹ This test method is under the jurisdiction of ASTM Committee D07 on Wood and is the direct responsibility of Subcommittee D07.07 on Fire Performance of Wood.

Current edition approved April 10, 2002. Published June 2002. Originally published as E 69 – 46 T. Last previous edition E 69 – 99.

² *Annual Book of ASTM Standards*, Vol 04.10.

³ *Annual Book of ASTM Standards*, Vol 04.07.

4. Significance and Use

4.1 The purpose of this test method is to provide a relative measurement of the combustibility of fire-retardant-treated wood specimens based on their percentage loss in weight under controlled fire exposure conditions **(1)**.⁴ In addition, other possible data include rate of weight loss, time of flaming and afterglowing, increase in temperature, and maximum vertical flame progress.

4.2 This test method is not sufficiently large scale to evaluate the suitability of a given treated product for building construction, but it is a convenient method to use for purposes of development or as a quality-control test during manufacture.

4.3 This test method gives a procedure for sampling and preparation of test specimens from a lot of treated material in which complete penetration is a requirement. A procedure is also given for the sampling of charges at a treating plant for purposes of quality control of the treatment process.

4.4 This test method has proven useful for evaluating comparative fire performance effectiveness of fire-retardant chemicals and treatment formulations for wood and wood products **(2-5)**.

4.5 In this test method, the specimens are subjected to one or more specific sets of laboratory test conditions. If different test conditions are substituted or the anticipated end-use conditions are changed, it may not be possible by or from this test method to predict changes in the fire-test-response characteristics measured. Therefore, the results are valid only for the fire test exposure conditions described in this procedure.

5. Apparatus

5.1 The apparatus for conducting the fire-tube test shall consist of the fire-tube assembly and accessory equipment as follows:

5.1.1 *Fire-Tube Assembly*—A specially constructed balance designed to indicate directly the percentage loss of weight suffered by the test specimen when exposed to a standardized flame for a given duration. Essential construction details of the apparatus assembly are shown in Fig. 1 and Fig. 2.

⁴ The boldface numbers in parentheses refer to the list of references at the end of this test method.

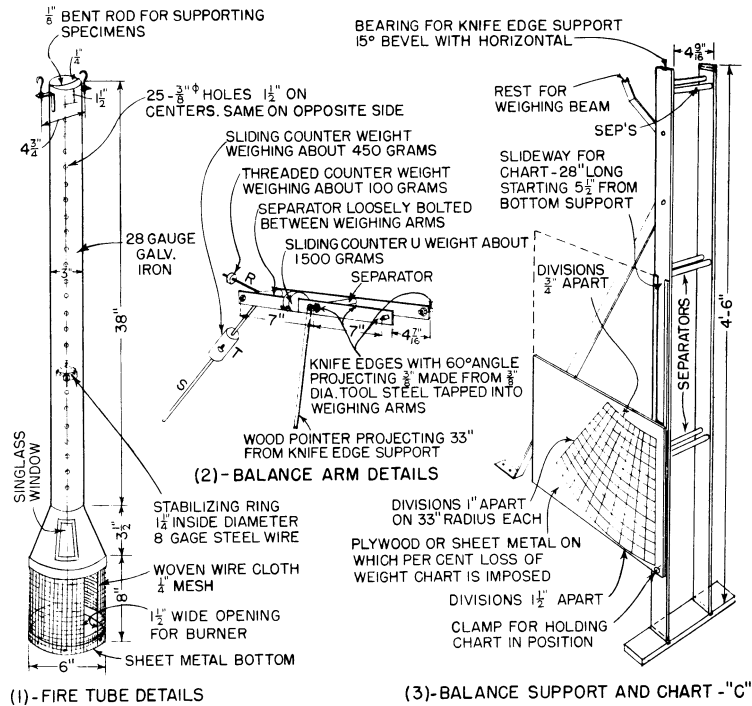

FIG. 1 Construction Details of Fire-Tube Apparatus

Inch-Pound Units
1/8 in.
1/4 in.
3/8 in.
1/2 in.
1 in.
1 1/4 in.
1 1/2 in.
3 in.
3 1/2 in.
4 1/16 in.

SI Units
3 mm
6 mm
9.5 mm
19 mm
25 mm
31.7 mm
38 mm
76 mm
89 mm
113 mm

Inch-Pound Units
4 9/16 in.
4 3/4 in.
5 1/2 in.
6 in.
8 in.
28 in.
33 in.
38 in.
4 ft 6 in.

SI Units
116 mm
121 mm
140 mm
152 mm
203 mm
711 mm
838 mm
965 mm
1.35 m

5.1.2 *Igniting Burner*—The igniting burner is to be of the low-form (curved-stem) bunsen type, having an inside tube diameter of 3/8 in. (9.5 mm) and attached to a ring-stand support. The igniting burner shall be provided with a device to maintain a constant gas flow, as described in 5.1.2.1 and the flame calibration, as required by 9.4.

5.1.2.1 *Gas Flow Device*—Typical devices utilized to control gas flow are manometers, pressure regulators or gas flowmeters with a rating of 0 to 5 SCFH (0 to 142 L/h). A gas flowmeter is desirable since they are readily available, very accurate, and inexpensive.

5.1.3 *Temperature-Indicating Apparatus*—A thermometer or thermocouple equipment that will indicate temperatures up to 1000°F (538°C).

5.1.4 *Timer*—A timing device capable of being read to minutes and seconds.

5.1.5 *Balance*—A balance with readability of 0.1 g and suitable for weighing test specimens and moisture-content samples.

5.1.6 *Oven*—A suitable thermostatically controlled oven for moisture-content determinations.

6. Sampling and Test Specimens for Wood Impregnated Throughout Entire Section

6.1 For interior trim or other lumber requiring penetration of treating solution throughout the section (but not for wood given incomplete penetration), the test specimens shall be prepared as follows:

6.1.1 At least one sample shall be taken from the lot for each 5000 bd ft or fraction thereof. Different species, and pieces of the same species with widely different thicknesses, shall be considered as separate lots and sampled accordingly. The samples shall be selected so as to include material from different sections of a finished unit or different lengths of finished trim, or to include variations such as heartwood or sapwood, rate of growth, density, and other visible nonuniformities. Samples shall be cut not closer than 2 ft (0.6 m) from the ends of treated boards.

6.1.2 Not less than five tests shall be made from each sample, except that where the quantity is less than 2000 bd ft the number of tests shall be left to the discretion of the testing authority but shall be not less than two.

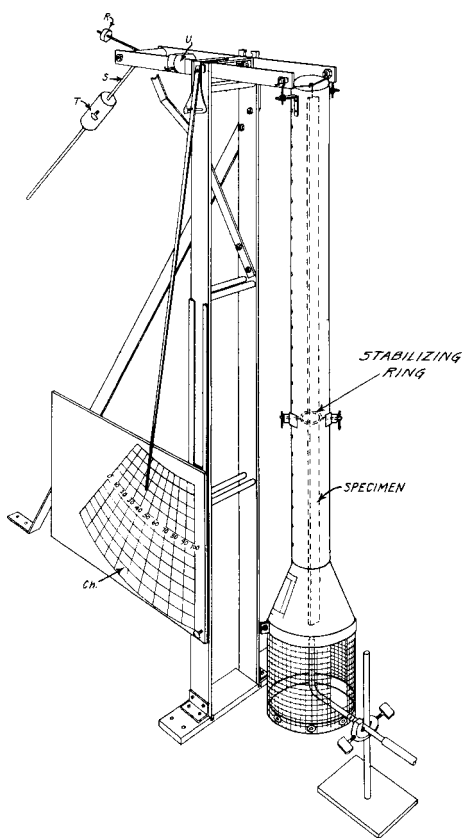

FIG. 2 Assembly of Fire-Tube Apparatus for Procedure A

6.1.3 The standard specimens cut from the selected samples shall be $\frac{3}{8}$ by $\frac{3}{4}$ in. (9.5 by 19 mm) in cross section by 40 in. (1016 mm) in length, with surfaces smooth-sawed to dimensions within $\pm\frac{1}{32}$ in. (0.8 mm). Each test specimen shall consist of one piece sawed the full 40-in. length or shall be made up of several shorter pieces joined at squared ends with six small wire staples at each joint to give a combined length of 40 in.

6.1.4 From samples taken from boards having thicknesses of $\frac{3}{4}$ in. (19 mm) or more, the specimen shall be prepared by cutting $\frac{3}{8}$ by $\frac{3}{4}$ -in. (9.5 by 19-mm) pieces longitudinally, not nearer than $\frac{3}{8}$ in. from the edge of the sample, and so that the face of the sample appears as one, or both, of the $\frac{3}{8}$ -in. edges of the specimen; provided, however, that if the thickness of the sample exceeds $1\frac{1}{2}$ in. (38 mm) an additional test specimen shall be cut from the center of the piece with the $\frac{3}{8}$ -in. edge parallel to the edge of the sample.

6.1.5 From samples taken from boards having thicknesses of $\frac{3}{8}$ in. (9.5 mm) or more but less than $\frac{3}{4}$ in. (19 mm), the specimen shall be prepared by cutting $\frac{3}{8}$ by $\frac{3}{4}$ -in. pieces longitudinally not nearer than $\frac{3}{8}$ in. from the edge of the same and so that the face of the sample appears as one, or both, of the $\frac{3}{4}$ -in. faces of the specimen.

6.1.6 When the material to be tested is less than $\frac{3}{8}$ in. (9.5 mm) in thickness, a specimen built up in laminated form with plies of approximately equal thickness is acceptable. The plies shall be dressed smooth and assembled by nailing with $\frac{3}{8}$ -in. steel-wire brads (No. 20 Bwg, 0.035-in. nominal thickness).

The weight of nails used shall be recorded for correction of the weight of the specimen.

6.1.7 A composite specimen prepared from more than one sample piece shall be taken so as to be representative of the average quality of the materials to be tested.

7. Sampling and Test Specimens

7.1 Where arrangements are made for sampling of each charge at the treating plant, the specimens shall be obtained as follows:

7.1.1 No charge shall contain less than six sample pieces. These sample pieces shall be of Douglas fir or of the same species and commodity (lumber, plywood, and so forth) of wood as the rest of the material in the charge. Each sample shall bear an identification mark.

7.1.2 Placement of sample pieces in the material to be treated on a tram shall be representative of the average exposure to the treating solution and yet be accessible for ready removal without seriously disturbing the loading.

7.1.3 Sample pieces shall be $\frac{3}{8}$ by $\frac{3}{4} \pm \frac{1}{32}$ in. (9.5 by 19 ± 0.8 mm) in cross section and be at least 42 in. (1.1 m) in length.

7.1.4 Fire-tube test specimens shall be cut from each selected sample and shall be 40 in. (1.016 m) in length, within $\pm\frac{1}{32}$ in. (0.8 mm). The remainder of the sample 2-in. (51-mm) or greater in length shall be cut off for moisture test specimens.

8. Conditioning

8.1 The moisture content of the specimen when tested shall be 7 ± 3 weight % of the dry material. Make the moisture determination for each specimen on a piece $\frac{3}{8}$ by $\frac{3}{4}$ in. (9.5 by 19 mm) in cross section and 2 to 8 in. (51 to 203 mm) in length, cut adjacent to one end of the specimens. Weigh the moisture test specimen and the fire tube test specimen to the nearest 0.1 g or less and record. Dry the moisture test specimen for 24 h at $212 \pm 3^\circ\text{F}$ ($100 \pm 1.7^\circ\text{C}$) or until a constant weight is achieved. Constant weight is achieved when readings are taken 2 h apart and agree within 0.2 %. Calculate the moisture content as follows:

$$X = [W_i - W_{OD}] / W_{OD} \times 100 \quad (1)$$

where:

- X = moisture content of the moisture test specimen, %
- W_i = initial weight of the moisture sample, and
- W_{OD} = oven dry weight of the moisture sample.

If the moisture content exceeds 10 %, condition the fire tube test sample or prepared specimen by drying at temperatures not exceeding 160°F (71°C) until the moisture content is within the prescribed limits of 4 to 10 %. If the moisture content of the specimen is less than 4 %, the moisture content can be increased by storing the specimen on a wire screen placed over a pan of water. If not tested immediately, store the specimen, after conditioning, in such a manner as to prevent absorption or loss of water.

8.2 Calculate the weight to which the fire tube test specimen must be conditioned to contain 10 % moisture as follows:

$$W_t = [110 / (100 + X)] \times W_o \quad (2)$$

where:

- W_t = desired weight of the fire tube test specimen containing 10 % moisture at time of test,
- W_o = original weight of the fire tube test specimen before conditioning, and
- X = moisture content of the moisture test specimen, %.

NOTE 1—If, for example, $X = 15\%$ and the $W_o = 145\text{ g}$, the specimen would be dried to a weight of $0.96 W_o$ or 138.7 g to contain 10 % moisture.

8.3 Calculate the weight to which the fire tube test specimen must be conditioned to contain 4 % moisture as follows:

$$W_t = [104/(100 + X)] \times W_o \quad (3)$$

where W_t is the desired weight of the fire tube test specimen containing 4 % moisture at time of test.

9. Procedure A

9.1 Use Procedure A where a continuous check on the percentage loss of weight of specimens during exposure to the flame is to be made.

9.2 Conduct the test either in a room free of violent drafts or in a laboratory hood.

9.3 Adjust the temperature probe so that the tip of the thermometer or thermocouple is flush with and in the center of the top plane of the test apparatus.

9.4 *Adjustment of Burner*—Place the burner within the empty fire tube, so that the top of the burner is 1 in. (25 mm) below a 40 in. (1.02 m) fire tube specimen hung in place with a 1/4 in. (6 mm) cup hook. Adjust the burner and gas regulator to give a blue flame approximately 11 in. (279 mm) in height, with a tall indistinct inner cone. Regulate the flame further to produce a temperature of $356 \pm 9^\circ\text{F}$ ($180 \pm 5^\circ\text{C}$) at the top of the fire tube. This setting should be maintained for at least 1 min to be sure that the flame has stabilized. When the adjustment is satisfactory, withdraw the lighted burner from the fire tube.

9.5 *Adjustment of Fire-Tube Weighing Apparatus*—After ensuring that the beam and fire tube swing freely on their respective knife edges, adjust the apparatus (Note 2) as follows so that the end of the pointer comes to rest:

9.5.1 At the 100 % mark on the loss-of-weight chart when the previously warmed fire tube is empty except for a screw hook used for suspending the specimen, and

9.5.2 At the 0 % mark when the fire tube contains the suspended specimen.

NOTE 2—Adjustment 7.4.1 is made by suitable manipulation of the counter-weights R and T (Fig. 1), with Rod S forming an angle of approximately 45° with the vertical. Adjustment 7.4.2 is made by appropriately raising or lowering Chart C . To obtain both adjustments with abnormally heavy or light specimens it may be necessary to rotate Rod S more toward the horizontal or vertical position or to change the position of Weight U . The knife edges of the beam will operate most satisfactorily when the pointer indicates 50 on the chart with the beam in an approximately horizontal position.

9.6 *Exposure of Test Specimen*—Insert the lighted burner within the fire tube so that the top of the burner is 1 in. (25 mm) below the lower extremity of the specimen with the standardized flame centered on the specimen. Apply the flame to the test specimen for 4 min after which withdraw it from the fire tube.

9.7 *Observations*—Record at 1/2-min intervals the percentage loss of weight suffered by the test specimen, as indicated by the end of the pointer on the percentage-loss-of-weight chart, until the loss of weight for a 1-min period does not exceed 1 %. The percentage loss of weight shall be considered a measure of the combustibility of the specimen.

NOTE 3—Char that breaks away from the specimen during the test will be retained on the sheet metal bottom of the fire tube. Thus, the weight of this char will be included in the weight of the unburned portion of the specimen.

10. Procedure B

10.1 Use Procedure B where only the final percentage loss of weight of specimens exposed to the flame is to be reported. It is an abridged form of Procedure A.

10.2 It is permitted to eliminate the specially constructed balancing parts of the fire-tube apparatus, as described in 5.1. Under such conditions support the fire-tube elements of the apparatus (shown in Fig. 1) in a vertical position by suspending the tube from the top as shown in Fig. 3 or by means of a clamp or other suitable supports for holding the tube vertical.

10.3 Calculate the final percentage loss of weight from the initial and final weights of the test specimen as

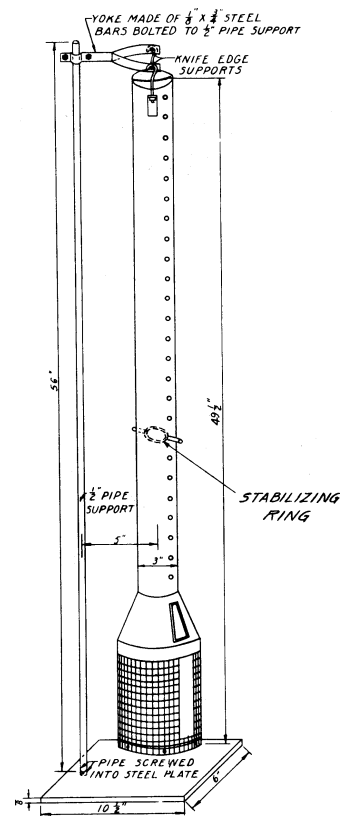

FIG. 3 Assembly of Fire-Tube Apparatus for Procedure B

		SI Equivalents	
in.	mm	in.	mm
1/8	3	5	127
3/16	9.5	6	152
1/2	12.7	10 1/2	267
3/4	19	49 1/2	1257
3	76	56	1422

$$\% \text{ Weight loss} = [(W_i - W_f) / W_i] \times 100 \quad (4)$$

where:

W_i = initial weight, lb(g), and

W_f = final weight, lb(g).

11. Report

11.1 Report the following information:

11.1.1 The percentage moisture content of the test specimens,

11.1.2 The final percentage loss of weight of each specimen after all flaming and glowing has ceased, and

11.1.3 The percentage loss of weight at an intermediate exposure period for each specimen, if so specified in the acceptance requirements for the material tested.

12. Precision and Bias

12.1 *Precision*—The precision of this test method is unknown.

12.2 *Bias*—The procedure in this test method for measuring final percentage loss of weight of specimens exposed to the flame as a measure of combustibility has no bias because the value of the percentage weight loss is defined only in terms of this test method.

13. Keywords

13.1 combustibility; fire retardants; flammability

REFERENCES

- (1) Truax, T. R., and Harrison, C. A., "A New Test for Measuring the Fire Resistance of Wood," *ASTM Proceedings*, Vol 29 (II), 1929, pp. 973-989.
- (2) Eickner, H. W., and Schaffer, E. L., "Fire-Retardant Effects of Individual Chemicals on Douglas-Fir Plywood," *Fire Technology*, Vol 3 (2), May 1967, pp. 90-104.
- (3) Truax, T. R., Harrison, C. A., and Baechler, R. H., "Experiments in Fireproofing Wood—Fifth Progress Report," American Wood Preservers Association Proceedings, 1935, pp. 231-245.
- (4) Report on "Comparative Fire Tests of Treated and Untreated Wood," prepared by Subcommittee II on Fire Tests of Lumber of Committee C-5, *ASTM Proceedings*, Vol 41, 1941, pp. 238-276.
- (5) Andrews, L. K., "A Study of Fireproofing Standards for Pressure-Treated Lumber," *Proceedings American Wood Preservers Association*, 1942, pp. 462-481.

ASTM International takes no position respecting the validity of any patent rights asserted in connection with any item mentioned in this standard. Users of this standard are expressly advised that determination of the validity of any such patent rights, and the risk of infringement of such rights, are entirely their own responsibility.

This standard is subject to revision at any time by the responsible technical committee and must be reviewed every five years and if not revised, either reapproved or withdrawn. Your comments are invited either for revision of this standard or for additional standards and should be addressed to ASTM International Headquarters. Your comments will receive careful consideration at a meeting of the responsible technical committee, which you may attend. If you feel that your comments have not received a fair hearing you should make your views known to the ASTM Committee on Standards, at the address shown below.

This standard is copyrighted by ASTM International, 100 Barr Harbor Drive, PO Box C700, West Conshohocken, PA 19428-2959, United States. Individual reprints (single or multiple copies) of this standard may be obtained by contacting ASTM at the above address or at 610-832-9585 (phone), 610-832-9555 (fax), or service@astm.org (e-mail); or through the ASTM website (www.astm.org).