

This document is not an ASTM standard and is intended only to provide the user of an ASTM standard an indication of what changes have been made to the previous version. Because it may not be technically possible to adequately depict all changes accurately, ASTM recommends that users consult prior editions as appropriate. In all cases only the current version of the standard as published by ASTM is to be considered the official document.



Designation: E 405 – 89 (Reapproved 1996)^{e1}



Standard Test Methods for Wear Testing Rotary Operators for Windows¹

This standard is issued under the fixed designation E 405; the number immediately following the designation indicates the year of original adoption or, in the case of revision, the year of last revision. A number in parentheses indicates the year of last reapproval. A superscript epsilon (ϵ) indicates an editorial change since the last revision or reapproval.

~~^{ε1} Note—Keywords were added editorially in September 1996.~~

¹ These test methods are under the jurisdiction of ASTM Committee E-6 E06 on Performance of Buildings and are the direct responsibility of Subcommittee E06.51 on Component Performance of Windows, Curtain Walls, Doors, Skylights, and Doors-Curtain Walls.

Current edition approved Feb. 24, 1989; April 1, 2004. Published April 1989; 2004. Originally published as E 405 – 70; approved in 1970. Last previous edition E 405 – 70 (1984); approved in 1996 as E 405 – 89 (1996) ^{ε1}.

1. Scope

1.1 These test methods describe the wear testing of gear-type rotary operating devices used for opening and closing windows (Note 1).

1.2 These test methods do not directly determine the effects of varying environmental conditions but may be employed after environmental exposure to evaluate the effect of such exposure.

1.3 These test methods are not intended to evaluate the structural adequacy of the operator in resisting the maximum force to which it may be subjected.

NOTE 1—Certain types of rotary window operators, such as torque-bar operators and telescopic operators cannot be tested by these test methods.

1.4 The values stated in inch-pound units are to be regarded as the standard. The metric equivalents of inch-pound units may be approximate.

1.5 *This standard does not purport to address all of the safety concerns, if any, associated with its use. It is the responsibility of the user of this standard to establish appropriate safety and health practices and determine the applicability of regulatory limitations prior to use.* For a specific hazard statement, see Note 3: 9.1.2.

2. Referenced Documents

2.1 *ASTM Standards:*²

E 631 Terminology of Building Constructions

3. Terminology

3.1 *Definitions*—Definitions are in accordance with Terminology E 631 unless otherwise indicated.

3.2 *Definitions of Terms Specific to This Standard:*

3.2.1 *closing torque, n*—a constant torque applied to the input shaft when the operator is in the fully closed position, simulating the forces applied by a person tightly closing the window and shall be expressed in pound-force-inches (or newton metres).

3.2.2 *fully closed position of the operator, n*—the position of the operator with the window in a fully closed position.

3.2.3 *fully opened position of the operator, n*—the position of the arm from 2 to 5° short of locking the mechanism with the window in an open position.

3.2.4 *gear-type rotary operator, n*—a mechanical operating device for opening and closing windows. It consists basically of an operating handle turning an input shaft which drives a gear mechanism that causes an arm or arms to pivot, operating the window.

3.2.5 *operating moment, n*—the product of the applied force and the length of the output lever arm from the point of load application to the pivot axis. It shall be expressed in pound-force-inches (or newton metres). During a test cycle, the operating moment varies from a maximum value with the arm in a centered position (peak operating moment) to some lesser value as the arm is moved away from the centered position.

3.2.6 *operator test specimen, n*—an entire, assembled gear-type rotary operator, including the operating handle.

3.2.7 *test cycle, n:*

3.2.7.1 *Test Method A*— fully opening and fully closing the operator.

² For referenced ASTM standards, visit the ASTM website, www.astm.org, or contact ASTM Customer Service at service@astm.org. For *Annual Book of ASTM Standards*, Vol 04.11, volume information, refer to the standard's Document Summary page on the ASTM website.

3.2.7.2 *Test Method B*— the number of rotations of the handle to open and close the operator fully.

3.2.8 *test force, n, for Test Method A*—the force applied to the operator arm at the point of attachment. The required test force in pounds-force (or newtons) is equal to the specified peak operating moment in pound-force-inches (or newton metres) divided by the distance in inches (or metres) measured perpendicular to the line of action of the force from the pivot axis to the point of attachment.

4. Summary of Test Methods

4.1 These test methods consist of subjecting the rotary operator to an operating moment against which the operator shall work in a cyclic function of opening and closing. Test Method A evaluates the operator for its ability to resist wear through a given number of cycles against the test moment with a specified torque applied to the input shaft. Test Method B evaluates only the rotating fingergrip portion of handle assemblies having rotating fingergrips.

5. Significance and Use

5.1 These tests provide standard methods for evaluating the mechanical performance of the rotary-type window operators, while the operators are subjected to cyclic wear in opening and closing against the operating moment.

6. Apparatus

6.1 The apparatus described is general in nature and any arrangement of equipment capable of performing the test procedure within the allowable tolerances is permitted.

6.2 *Test Method A:*

6.2.1 The test apparatus for Test Method A shall consist of a frame for mounting the rotary operator with the operator arm(s) centered (approximately the center of travel); test weights up to 5 lbs (2280 g) accurate to within ± 1.0 % or test weights above 5 lbs (2280 g) accurate to within ± 0.5 %, attached by flexible cable to the arm(s) to provide the required test forces; an attachment bolt fastening the cable to the arm; a torque-limiting clutch, whose output is within ± 15 % of the specified closing torque, attached to the handle drive mechanism in line with the operator input shaft and driven by a reversible ~~air or electric~~ motor; and limit switching devices to effect reversal of rotation at the fully open and fully closed operator positions (see Fig. 1).

6.2.2 The arm or the test attachment bolt through the arm shall bear against the test frame, if necessary, to prevent the arm from closing beyond the nominal fully closed position. The cables shall be adjustable to provide an equal tension force in both the cables when the test attachment point and pivot are centered.

6.2.3 Fig. 2 shows how, if a vertical arrangement were used, to test a single-arm operator, a system of two test weights, an upper weight equal to the test force, and a lower weight of twice the test force, would act to provide the required downward force when the arm is above the center position of its travel and the same force upward when the arm is below the center of its travel. For operators with two arms, sum of the test weight on each arm should equal the total test weight with neither arm seeing less than 25 % of the total test weight. The test weight is to be divided proportionally to simulate the loading seen in actual use. Fig. 3 shows a typical handle drive fork used to operate the rotary operator. If it is impractical to drive certain operating handles through their grip portion, they may be modified so that portion making the connection to the operator input shaft is used as part of the test operator.

6.3 *Test Method B:*

6.3.1 The test apparatus for Test Method B shall consist of a motor, shaft, timer, test weight, and attaching collar. The reversible ~~air or electric~~ motor drives a horizontal shaft to which the test handle is attached. The shaft shall be obtained by removing the input shaft from an operator or as an additionally supplied part. The handle end of the shaft shall be identical to the input shafts of the test operators. The timing device effects a reversal of the motor at required intervals. The split collar carries the test weight and attaches to the rotating fingergrip of the handle causing one revolution of the fingergrip with respect to the handle for each revolution of the handle (see Fig. 4).

7. Test Specimens

7.1 The operator test specimens shall be representative in all respects of the operators to be qualified under these test methods. Unless otherwise specified, the specimens shall consist of six identical production samples of the complete rotary operator, four of which shall be selected at random for testing. The remaining two samples shall be identified and filed with the four tested specimens as part of the retained sample.

7.2 Handles shall be included in all test specimens. Where several styles of handles are furnished to fit different models of operators having identical input shaft ends, handles tested on one model of operator shall be considered tested at that test operating moment and closing torque on all models of operators with identical shaft ends.

8. Required Information From Specifying Authority

8.1 The specifying authority shall provide the following information:

8.1.1 Identification of the test samples,

8.1.2 The required peak operating moment, in some full multiple of 10 lbf·in. (1.1 N·m),

8.1.3 The required closing torque, in some full multiple of 5 lbf·in. (0.55 N·m), and

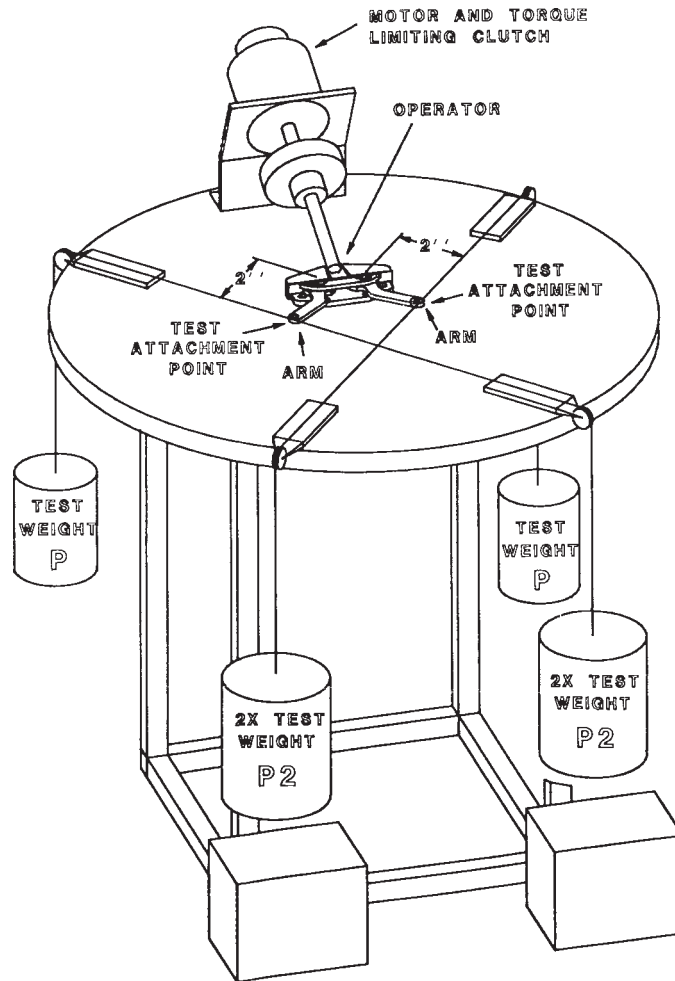

FIG. 1 Typical Operator Test Apparatus

8.1.4 The number of test cycles required if no prior failure occurs. (A minimum of 3500 cycles are recommended.)

8.2 The authority requesting the operator testing shall provide the test laboratory with load distribution information for the arms of two arm operators to be tested.

NOTE 2—Care must be exercised in providing the above information to ensure the specified requirements are not in conflict with the specification, and that the required closing torque is compatible with the necessary operating torque. Since the torque-limiting clutch normally used to establish the maximum closing torque during the test also establishes the maximum operating torque that can be applied to the window, the minimum value of closing torque that is practical is determined by the necessary operating torque.

9. Procedure

9.1 Test Method A—Operator :

9.1.1 Select a practical output-arm length to allow application of the specified operating moment without causing difficulty in the design and operation of the test apparatus. Drill a hole in the end of the output arm to provide an attachment location for testing purposes. Note the output-arm length and method of attachment in the test report.

9.1.2 Install the rotary operator in the test frame at an angle, if necessary, with the arm perpendicular to the line of action of the test force when at the center of its travel. (If the operator has two arms, both arms are to be treated the same with the sum of the operating moments on each arm equal to the total peak operating torque specified.) Adjust the cables to provide balanced loads on the attachment bolt when the test attachment point and pivot are on a line perpendicular to the line of action of the test force. As the operator handle is turned to move the arm toward the fully closed position, the test weights will provide an opposing test force until the arm is in its fully closed position simulating the forces applied by a person tightly closing a window. Apply the torque for a minimum of at least 0.25 s, not to exceed 5 s. Maintaining the opposing test force, reverse the drive motor causing the arm to move back to the centered position. As the arm continues to move toward the fully open position, the test weights provide an opposing test force. When the arm reaches its fully open position, reverse the drive motor, returning the arm to center. The operator input shaft rotation shall not exceed 50 r/min and shall be essentially uniform.

NOTE 3—**Caution:** Care uniform. (**Warning:** Care must be exercised to ensure that there is not excessive heating of the test sample due to friction at the higher shaft rotation speeds. Excessive temperature rise can result in operator performance degradation and an invalid test.)

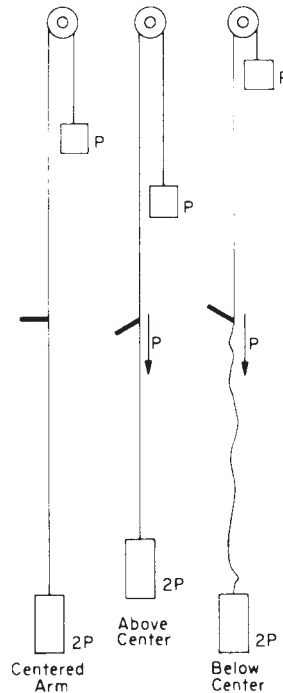

FIG. 2 Force on Operator Arm

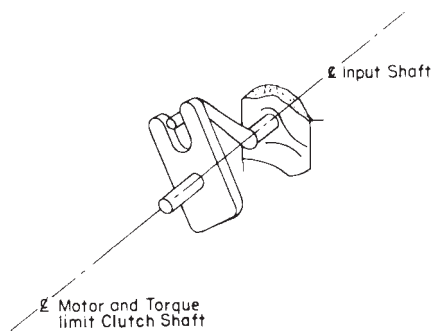

FIG. 3 Typical Handle Drive Fork

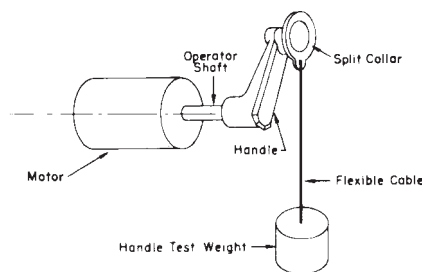

FIG. 4 Typical Handle Test Apparatus

9.1.3 The number of cycles to be run if no prior failure occurs shall be at the option of the specifier. The inability of the operator to raise the test weights constitutes failure.

9.2 Test Method B—Handle with Rotating Fingergrasp:

9.2.1 Mount the operating handle on the motor-driven horizontal shaft simulating the input shaft. Attach a circumferential collar to the operating handle centered along the rotating fingergrasp area. The handle test weight is calculated to apply a maximum torque to the operator shaft equal to the input torque required to develop the required peak-operating moment specified in 8.1.2 for the rotary operator of which the handle is a part. Fix the test-weight cable to the collar to cause one rotation of the fingergrasp, in relation to the handle, for each rotation of the handle. Stop the shaft rotation and reverse the direction of rotation at least once each minute. The shaft rotation shall not exceed 50 r/min and shall be essentially uniform.

9.2.2 If no prior failure occurs, stop the test when the number of cycles specified for the operator is reached. The inability of

the handle to raise the weight, or the failure of the rotating finger grip to rotate, or both, constitutes failure.

10. Report

10.1 Report the following information:

- 10.1.1 Date of tests and date of report,
- 10.1.2 Identification of the units tested,
- 10.1.3 The peak operating moment,
- 10.1.4 The distance from the pivot axis to the test load attachment point,
- 10.1.5 The motor torque applied in the fully closed position,
- 10.1.6 The number of cycles to which each of the operators and handles were subjected,
- 10.1.7 The condition of the operators and handles at the conclusion of the test, and
- 10.1.8 A statement that the tests were conducted in accordance with these test methods, or a full description of any deviation from these test methods.

11. Precision and Accuracy

- 11.1 The nature of this pass–fail test is such that no statement can be made as to its precision and accuracy.

12. Keywords

- 12.1 rotary operators; rotary windows; wear testing; windows

ASTM International takes no position respecting the validity of any patent rights asserted in connection with any item mentioned in this standard. Users of this standard are expressly advised that determination of the validity of any such patent rights, and the risk of infringement of such rights, are entirely their own responsibility.

This standard is subject to revision at any time by the responsible technical committee and must be reviewed every five years and if not revised, either reapproved or withdrawn. Your comments are invited either for revision of this standard or for additional standards and should be addressed to ASTM International Headquarters. Your comments will receive careful consideration at a meeting of the responsible technical committee, which you may attend. If you feel that your comments have not received a fair hearing you should make your views known to the ASTM Committee on Standards, at the address shown below.

This standard is copyrighted by ASTM International, 100 Barr Harbor Drive, PO Box C700, West Conshohocken, PA 19428-2959, United States. Individual reprints (single or multiple copies) of this standard may be obtained by contacting ASTM at the above address or at 610-832-9585 (phone), 610-832-9555 (fax), or service@astm.org (e-mail); or through the ASTM website (www.astm.org).